

Desired Future Condition Explanatory Report (Final)
Carrizo-Wilcox/Queen City/Sparta Aquifers for Groundwater
Management Area 13

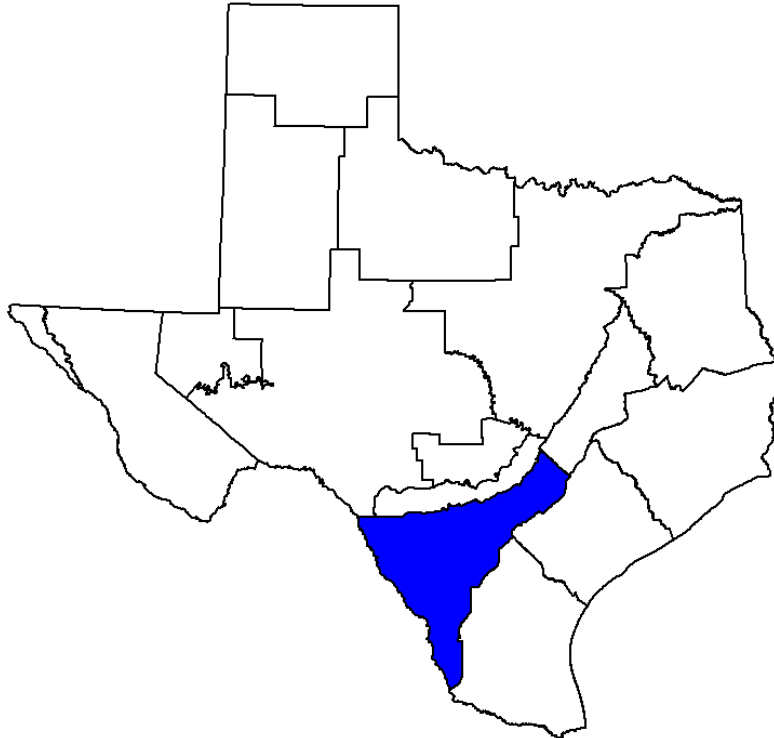

William R. Hutchison, Ph.D., P.E., P.G.
Independent Groundwater Consultant
9305 Jamaica Beach
Jamaica Beach, TX 77554
512-745-0599
billhutch@texasgw.com

February 22, 2017

Desired Future Condition Explanatory Report (Final)
Carrizo-Wilcox/Queen City/Sparta Aquifers fir Groundwater Management Area 13

Geoscientist and Engineering Seal

This report documents the work and supervision of work of the following licensed Texas Professional Geoscientist and licensed Texas Professional Engineers:

William R. Hutchison, Ph.D., P.E. (96287), P.G. (286)

Dr. Hutchison completed the analyses and model simulations described in this report, and was the principal author of the final report.

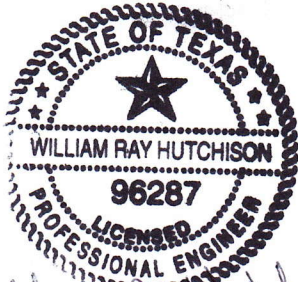

William R. Hutchison

2/22/2017

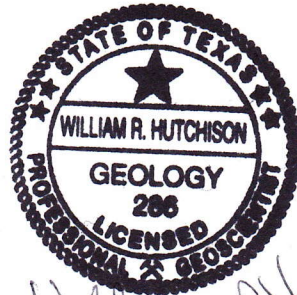

William R. Hutchison

2/22/2017

Table of Contents

1.0	Groundwater Management Area 13	3
2.0	Proposed Desired Future Condition	6
3.0	Policy Justification	7
4.0	Technical Justification.....	9
5.0	Factor Consideration.....	13
5.1	Aquifer Uses and Conditions	13
5.2	Water Supply Needs and Water Management Strategies	13
5.3	Hydrologic Conditions within Groundwater Management Area 13.....	15
5.3.1	Total Estimated Recoverable Storage	16
5.3.2	Average Annual Recharge, Inflows and Discharge	17
5.4	Other Environmental Impacts, Including Spring Flow and Other Interactions between Groundwater and Surface Water.....	19
5.5	Subsidence	19
5.6	Socioeconomic Impacts	19
5.7	Impact on Private Property Rights.....	20
5.8	Feasibility of Achieving the Desired Future Condition.....	20
5.9	Other Information	20
6.0	Discussion of Other Desired Future Conditions Considered.....	21
7.0	Discussion of Other Recommendations	22
8.0	References	23

List of Figures

Figure 1. Groundwater Management Area 13	3
Figure 2. Counties Entirely or Partially in GMA 13	4
Figure 3. Groundwater Conservation Districts in GMA 13	5
Figure 4. Conceptual Model of Flow (from Kelley and others, 2004, Figure 5.1)	10

List of Tables

Table 1. Alternative Estimates of Groundwater Availability	11
Table 2. Groundwater Budget for Groundwater Management Area 13	18

List of Appendices

Appendix A – Proposed Desired Future Condition Resolution

Appendix B – Groundwater Use Estimates

Appendix C – Comparison of Groundwater Monitoring Data with Groundwater Model Results, Groundwater Management Area 13

Appendix D – Water Supply Needs and Water Management Strategies Data

Appendix E – TWDB GAM Task 13-036 (Revised): Total Estimated Recoverable Storage for Aquifers in Groundwater Management Area 13

Appendix F – Paper authored by James Bene of R.W. Harden & Associates regarding the Joint Planning Process

Appendix G – Socioeconomic Impacts Analyses for Regions K, L, and M

Appendix H – James Bene PowerPoint: November 20, 2013 GMA 13 Meeting

Appendix I – GBRA letter of February 26, 2016 Regarding Surface Water Impacts

Appendix J – James Beach PowerPoint: March 30, 2016 Regarding Modeling Groundwater-Surface Water Interactions

1.0 Groundwater Management Area 13

Groundwater Management Area 13 is one of sixteen groundwater management areas in Texas, and covers a large portion of the southwest part of the state (Figure 1).

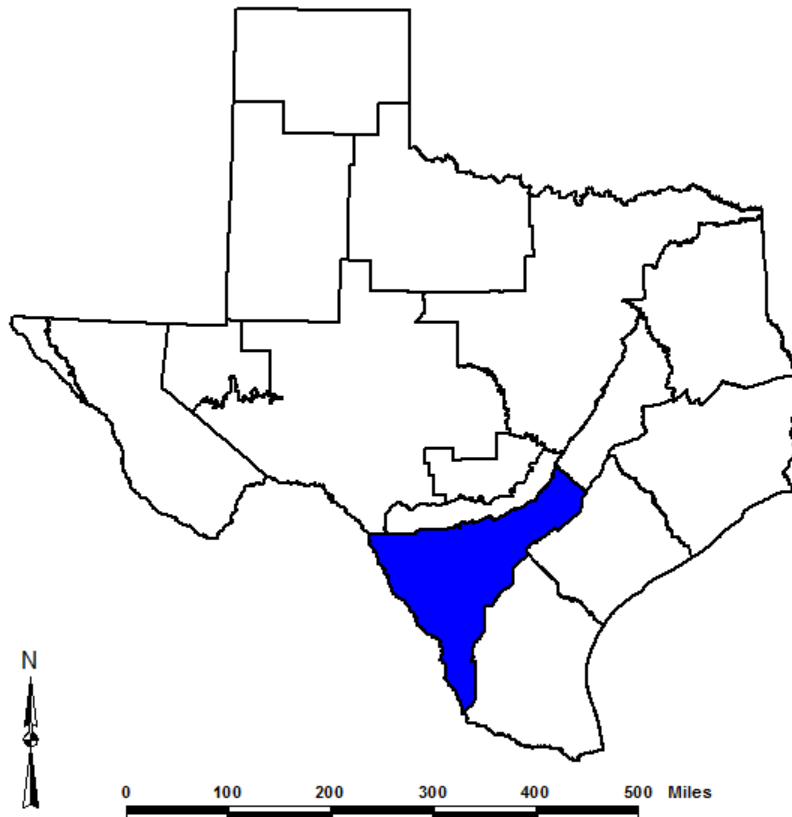

Figure 1. Groundwater Management Area 13

Groundwater Management Area 13 covers all or portions of the following counties: Atascosa, Bexar, Caldwell, Dimmit, Frio, Gonzales, Guadalupe, Karnes, La Salle, Maverick, McMullen, Medina, Uvalde, Webb, Wilson, Zapata, and Zavala (Figure 2).

There are nine groundwater conservation districts in Groundwater Management Area 13: Evergreen Underground Water Conservation District, Gonzales County Underground Water Conservation District, Guadalupe County Groundwater Conservation District, Edwards Aquifer

Desired Future Condition Explanatory Report (Final)
Carrizo-Wilcox/Queen City/Sparta Aquifers for Groundwater Management Area 13

Authority, McMullen Groundwater Conservation District, Medina County Groundwater Conservation District, Plum Creek Conservation District, Uvalde County Underground Water Conservation District, and Wintergarden Groundwater Conservation District (Figure 3). Please note that as shown in Figure 3, the Edwards Aquifer Authority overlaps other groundwater conservation districts in a small portion of Atascosa County, and larger parts of Caldwell, Guadalupe, Medina, and Uvalde counties.

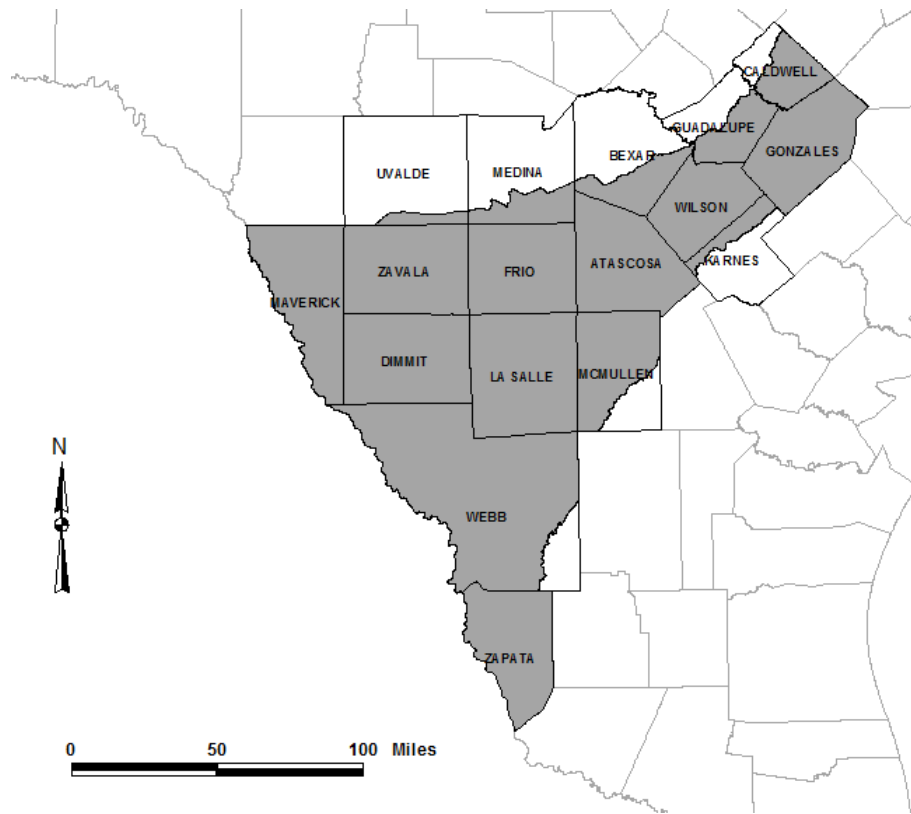

Figure 2. Counties Entirely or Partially in GMA 13

Desired Future Condition Explanatory Report (Final)
Carrizo-Wilcox/Queen City/Sparta Aquifers for Groundwater Management Area 13

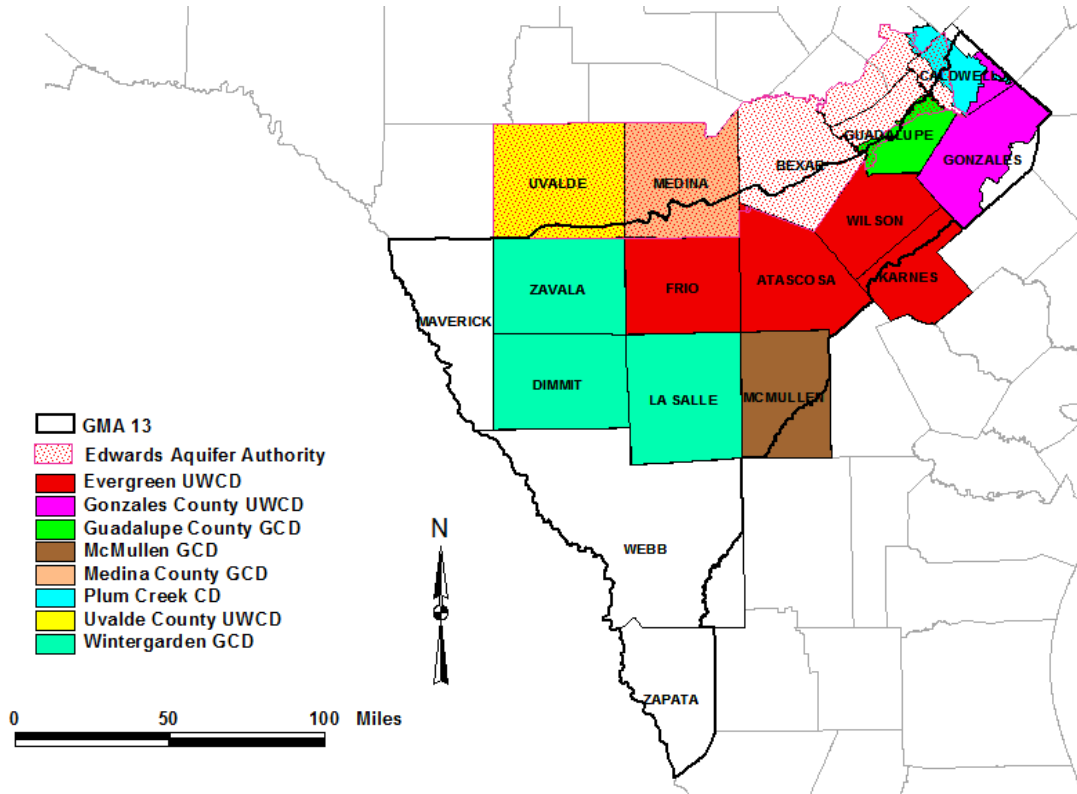

Figure 3. Groundwater Conservation Districts in GMA 13

2.0 Proposed Desired Future Condition

Due to limitations with the model as described in Technical Memorandum 16-08, two proposed desired future conditions were selected for the Carrizo-Wilcox/Queen City/Sparta aquifers as described below.

The first proposed desired future condition for the Carrizo-Wilcox/Queen City/Sparta Aquifers in Groundwater Management Area 13 is that 75 percent of the saturated thickness at the end of 2012 remains in 2070. This desired future condition is considered feasible despite model predictions to the contrary as detailed in Technical Memorandum 16-08.

In addition, a secondary proposed desired future condition for the Carrizo-Wilcox/Queen City/Sparta Aquifers in Groundwater Management Area 13 is an average drawdown of 48 feet for all of GMA 13. The drawdown is calculated from the end of 2012 conditions to the year 2070. This desired future condition is consistent with Scenario 9 as detailed in GMA 13 Technical Memorandum 16-01 and GMA 13 Technical Memorandum 16-08.

The vote to send the proposed desired future conditions to the groundwater conservation districts was taken at the April 27, 2016 meeting of GMA 13. Appendix A is the final resolution for the desired future conditions.

The geographic area covered by the proposed desired future condition is defined by the grid file for the Groundwater Availability Model of the Carrizo-Wilcox, Queen City, and Sparta aquifers (Kelly and others, 2004). This file (qcsp_s_grid_poly052212.csv) was downloaded from the Texas Water Development Board website:

<http://www.twdb.state.tx.us/groundwater/models/gam/qcsp/qcsp.as>

3.0 Policy Justification

As developed more fully in this report, the proposed desired future condition was adopted after considering:

- Aquifer uses and conditions within Groundwater Management Area 13
- Water supply needs and water management strategies included in the 2012 State Water Plan
- Hydrologic conditions within Groundwater Management Area 13 including total estimated recoverable storage, average annual recharge, inflows, and discharge
- Other environmental impacts, including spring flow and other interactions between groundwater and surface water
- The impact on subsidence
- Socioeconomic impacts reasonably expected to occur
- The impact on the interests and rights in private property, including ownership and the rights of landowners and their lessees and assigns in Groundwater Management Area 13 in groundwater as recognized under Texas Water Code Section 36.002
- The feasibility of achieving the desired future condition
- Other information

In addition, the proposed desired future condition provides a balance between the highest practicable level of groundwater production and the conservation, preservation, protection, recharging, and prevention of waste of groundwater in Groundwater Management Area 13.

There is no set formula or equation for calculating groundwater availability. This is because an estimate of groundwater availability requires the blending of policy and science. Given that the tools for scientific analysis (groundwater models) contain limitations and uncertainty, policy provides the guidance and defines the bounds that science can use to calculate groundwater availability.

The maximum amount of groundwater available is the amount of water stored in the aquifer plus groundwater “captured” by wells. The captured groundwater includes induced inflow into an area by pumping and reductions in natural discharge (e.g. spring flow surface water base flow). This is the extreme case where the goal is to entirely deplete, or mine, the aquifer. GMA 13 rejected this policy because it conflicts with the mission to conserve, preserve and protect the aquifers. One common definition of groundwater availability is the amount of water that can be recovered annually over a specified planning period without causing irreversible harm. The irreversible harm can include drying up existing wells and spring flow depletion, and are dependent on local conditions and policies. GMA 13 is in general agreement with this policy of determining groundwater availability because it coincides with the mission to conserve, preserve, and protect the aquifers.

After agreeing on a policy to estimate groundwater availability, the next step was to define the factors that would cause irreversible harm due to the impacts of such production on the system.

Desired Future Condition Explanatory Report (Final)
Carrizo-Wilcox/Queen City/Sparta Aquifers for Groundwater Management Area 13

These factors include:

- Economics of producing water from depth
- Intrusion of poor water quality due to changes in vertical flow gradients
- Interaction between stream flow and groundwater
- Changes in groundwater evapotranspiration rates
- Groundwater storage recovery rates
- Timeframe of pumping capture and sustainable pumpage

As developed more fully below, many of these factors could only be considered on a qualitative level since the available tools to evaluate these impacts have limitations and uncertainty.

4.0 Technical Justification

The proposed desired future condition for the Carrizo-Wilcox/Queen City/Sparta Aquifers was developed based on simulations of alternative scenarios of future pumping using the Groundwater Availability Model (GAM) of the Carrizo-Wilcox, Queen City, and Sparta aquifers (Kelley and others, 2004). This GAM superseded the GAM of the southern Carrizo-Wilcox Aquifer (Deeds and others, 2003). The GAM used in this process was developed to make predictions of groundwater availability through 2050 based on current projections of groundwater demands during drought-of-record conditions (Kelley and others, 2004, pg. xxvii). The calibration period for the GAM was 1980 to 1989, and the verification period was 1990 to 1999. The documentation for the GAM stated that the GAM provides an “integrated tool for the assessment of water management strategies to directly benefit state planners, Regional Water Planning Groups (RWPGs), and Groundwater Conservation Districts (GCDs)”. Furthermore, the documentation stated that based on the model grid (one square mile), the GAM is “not capable of predicting aquifer responses at specific points such as a particular well”, and that the GAM is “accurate at the scale of tens of miles, which is adequate to understand groundwater availability at the regional scale” (Kelley and others, 2004, pg. xxviii).

As detailed in Technical Memorandum 17-01, the model calibration period was extended, and this extended model was used to establish the initial conditions for all predictive scenarios. The calibration period of the model as published ended at the end of 1999. Technical Memorandum describes the effort to extend this period to the end of 2011 (12 additional stress periods). Thus, all predictive drawdown calculations use the end of 2011 as the initial groundwater elevation.

Conceptually, the model simulates groundwater flow in eight layers as shown in Figure 4. Due to the vertical interaction between aquifer units that is simulated in the GAM, the proposed desired future condition for all three aquifers were developed together.

Desired Future Condition Explanatory Report (Final)
 Carrizo-Wilcox/Queen City/Sparta Aquifers for Groundwater Management Area 13

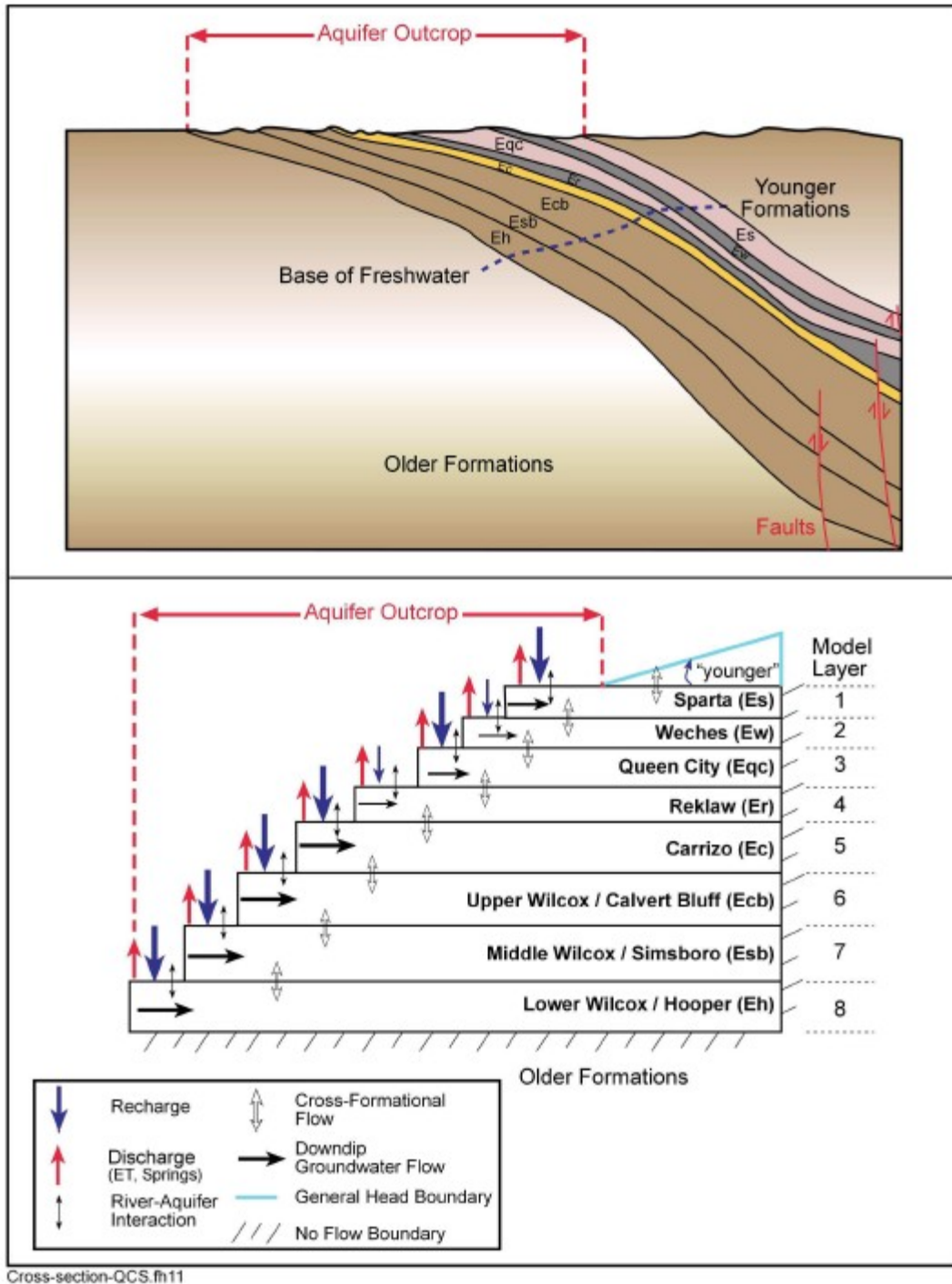

Figure 4. Conceptual Model of Flow (from Kelley and others, 2004, Figure 5.1)

Desired Future Condition Explanatory Report (Final)
Carrizo-Wilcox/Queen City/Sparta Aquifers for Groundwater Management Area 13

The limitations of the groundwater model for use in this process were of particular importance to GMA 13 and to stakeholders. Early in the process, GMA 13 completed a study to compare model results with actual groundwater elevation data. This report (known as the Task 0 report), demonstrated that predicted drawdowns and model predictions were not always in agreement.

GMA 13 reviewed various existing TWDB reports estimating groundwater availability and compared those to the MAGs developed by the TWDB for the existing DFCs. A summary of those results is presented in Table 1.

Table 1. Alternative Estimates of Groundwater Availability

TWDB Report No.	County	Aquifer	Trough-Method Availability Estimate (ac-ft/yr)	2060 MAG (ac-ft/yr)
4	Gonzales	Carrizo	85,000	69,371
210	Gonzales/Wilson	Carrizo	47,800	77,670
238	River Basin - Rio G., Guad., S.A., Nueces	Carrizo-Wilcox	174,400	403,192
Trans-TX	Gonzales	Carrizo-Wilcox	90,400	101,432
	Wilson	Carrizo-Wilcox	80,200	114,165
	Atascosa	Carrizo-Wilcox	85,600	75,808
	Bastrop	Carrizo-Wilcox	60,000	N/A

The analysis shows that the MAGs developed under the current DFCs are generally within the groundwater availability estimates in the TWDB Reports.

Report 238 states that approximately 174,400 ac-ft of groundwater as effective recharge is available annually for development in the Rio Grande, Guadalupe, San Antonio, and Nueces River Basins from 1977 to 2030 from the Carrizo-Wilcox Aquifer. This estimate is based on pumpage under assumed conditions (trough method) and is related to the ability of the aquifer to transmit water from the outcrop area to the areas of pumping. Only effective recharge would be available for development if the 400 ft water level constraints are to apply after 2030. Although recharge from precipitation to the Carrizo-Wilcox Aquifer appears to be more than adequate to supply the quantity of water that is calculated as effective recharge, the aquifers transmissive capacity limits the amount of annual effective recharge.

The process of using the groundwater model in developing desired future conditions revolves around the concept of incorporating many of the elements of the nine factors (e.g. current uses and water management strategies in the regional plan). In GMA 13, several model runs were completed and the results discussed prior to adopting a desired future condition. Some critics of the

Desired Future Condition Explanatory Report (Final)
Carrizo-Wilcox/Queen City/Sparta Aquifers for Groundwater Management Area 13

process asserted that the districts were “reverse-engineering” the desired future conditions by specifying pumping (e.g., the modeled available groundwater) and then adopting the resulting drawdown as the desired future condition. However, it must be remembered that among the input parameters for a predictive groundwater model run is pumping, and among the outputs of a predictive groundwater model run is drawdown. Thus, an iterative approach of running several predictive scenarios with models and then evaluating the results is a necessary (and time-consuming) step in the process of developing desired future conditions.

One part of the reverse-engineering critique of the process has been that “science” should be used in the development of desired future conditions. The critique plays on the unfortunate name of the groundwater models in Texas (Groundwater Availability Models) which could suggest that the models yield an availability number. This is simply a mischaracterization of how the models work (i.e. what is a model input and what is a model output).

The critique also relies on a narrow definition of the term *science* and fails to recognize that the adoption of a desired future condition is primarily a policy decision. The call to use science in the development of desired future conditions seems to equate the term *science* with the terms *facts* and *truth*. Although the Latin origin of the word means knowledge, the term *science* also refers to the application of the scientific method. The scientific method is discussed in many textbooks and can be viewed to quantify cause-and-effect relationships and to make useful predictions.

In the case of groundwater management, the scientific method can be used to understand the relationship between groundwater pumping and drawdown, or groundwater pumping and spring flow. A groundwater model is a tool that can be used to run “experiments” to better understand the cause-and-effect relationships within a groundwater system as they relate to groundwater management.

Much of the consideration of the nine statutory factors involves understanding the effects or the impacts of a desired future condition (e.g. groundwater-surface water interaction and property rights). The use of the models in this manner in evaluating the impacts of alternative futures is an effective means of developing information for the groundwater conservation districts as they develop desired future conditions.

5.0 Factor Consideration

Section 36.108(d) of the Texas Water Code requires that groundwater conservation districts include documentation of how nine listed factors were considered prior to proposing a desired future condition, and how the proposed desired future condition impact each factor. This section of the explanatory report summarizes the information that the groundwater conservation districts used in its deliberations and discussions.

5.1 Aquifer Uses and Conditions

For the purposes of the development of a proposed desired future condition, the groundwater conservation districts in Groundwater Management Area 13 considered the following in the category of aquifer uses (i.e. pumping):

- Estimates of 1999 pumping from the GAM (Kelley and others, 2004)
- Estimates of pumping from 2000 to 2008 from the TWDB Water Use Survey database
- Estimates of pumping from Gonzales County UWCD for the years 2000 to 2011
- Estimates of pumping from Plum Creek CD for the years 2000 to 2011

The information considered by the groundwater conservation districts in Groundwater Management Area 13 is presented in Appendix B.

For the purposes of the development of a proposed desired future condition, the groundwater conservation districts in Groundwater Management Area 13 considered groundwater monitoring data (i.e. groundwater elevations) from wells in the TWDB groundwater database. The monitoring data were compared to groundwater elevation from the calibrated GAM (Kelley and others, 2004), and with future projections of groundwater elevations from Scenario 4 of TWDB GAM Run 09-034 (Wade and Jigmond, 2010) that was the basis of the desired future condition adopted in 2010. This comparison also included evaluating the pumping that was estimated in the calibrated GAM for the period 1980 to 1999, and estimated future pumping associated with Scenario 4 of TWDB GAM Run 09-034 (the basis for the desired future condition adopted in 2010). This evaluation was detailed in a report completed for Groundwater Management Area 13 (Hutchison, 2013), and is included as Appendix C. This report was circulated as a draft report on December 21, 2012 and public comments were solicited and received. The final report was issued on March 20, 2013, and includes a response to those comments.

5.2 Water Supply Needs and Water Management Strategies

Initially, data from the 2012 State Water Plan were used by the groundwater conservation districts of Groundwater Management Area 13 in considering this factor. Specifically, county-by-county data on groundwater sources, groundwater demands, and water management strategies. In

Desired Future Condition Explanatory Report (Final)
Carrizo-Wilcox/Queen City/Sparta Aquifers for Groundwater Management Area 13

addition, data from the Bureau of Economic Geology report that presents estimates of oil and gas water use (Nicot and others, 2012) were considered. SAWS provided an update to pumping projections in southern Bexar County and Gonzales County on June 27, 2013 via email.

Groundwater Conservation District input included:

- Guadalupe County Groundwater Conservation District
- Gonzales County Underground Water Conservation District
- McMullen Groundwater Conservation District
- Plum Creek Conservation District
- Wintergarden Groundwater Conservation District

Tabular summaries of all these data are presented in Appendix D.

Appendix D also includes the Modeled Available Groundwater Report (Wade, 2012) that was developed by TWDB associated with the previously developed desired future condition adopted in 2010.

The data and estimates in Appendix D provide a range of estimates of future pumping that were considered in completing the initial eight scenarios that were developed and run with the GAM through the year 2070. A base case (Scenario 4) was developed based on input from the groundwater conservation districts in GMA 13 as follows:

- Pumping in the Carrizo Aquifer in Bexar County was increased as compared to the MAG that was developed from the DFC that was adopted in 2010 in response to a request from SAWS
- Pumping in the Carrizo Aquifer in Gonzales County was increased as compared to the MAG that was developed from the DFC that was adopted in 2010 in response to a request from Gonzales County UWCD
- Pumping the Wilcox Aquifer in Gonzales County was decreased as compared to the MAG that was developed from the DFC that was adopted in 2010 in response to a request from Gonzales County UWCD
- Pumping in the Carrizo Aquifer in McMullen County was increased as compared to the MAG that was developed from the DFC that was adopted in 2010 in response to a request from McMullen GCD

Scenarios 1 to 3 represented incremental reductions of Scenario 4, and Scenarios 4 to 7 represented incremental increases of Scenario 4.

After reviewing the results, Scenario 8 was completed which represented the following changes to Scenario 4:

- Gonzales County UWCD requested that pumping be revised to match the current MAG
- Guadalupe County GCD requested increases in both the Carrizo and Wilcox aquifers

Results of Scenario 8 were completed and reviewed at the GMA 13 meeting of March 13, 2014. Because of the comments received at the March 13, 2014 meeting, additional pumping was to be

Desired Future Condition Explanatory Report (Final)
Carrizo-Wilcox/Queen City/Sparta Aquifers for Groundwater Management Area 13

included in the next simulation that reflected additional pumping by SAWS. However, due to changes in the administration in GMA 13, the work was left pending as of mid-2014.

In considering the request of SAWS to simulate additional pumping, and the potential incremental effect of each entity in GMA 13 requesting similar simulations in the future, a more comprehensive approach was employed to consider all recommended and alternative water management strategies from the Region L plan. Sam Vaughn of HDR provided the initial data on August 22, 2014. However, due to the imminent release of the Region L IPP, it was decided to wait until the IPP was released to ensure that all strategies were current.

A meeting with HDR was held on May 27, 2015 to clarify the strategies and the data contained in the IPP. The IPP contained 12 strategies that were relevant to GMA 13. One of these was a collective strategy called “Local Carrizo Wells” that covered several areas in GMA 13. The pumping for all other strategies totaled 116,000 AF/yr in 2020, and 222,000 AF/yr in 2070.

The IPP distinguished between recommended and alternative strategies in areas where future pumping exceeded the MAG that was set in 2010 consistent with the DFC that was established by GMA 13. Water management strategies are developed to meet deficits between current supply and future demand as part of the regional planning process. TWDB considers the MAG to be a hard limit, and recommended water management strategies cannot result in pumping that exceeds the MAG. Thus, Region L has included strategies that exceed the MAG as alternative strategies.

Technical Memorandum 16-01 summarized four simulations that focused on simulating the recommended and alternative water management strategies in the 2015 Region L plan. Scenario 9 includes all pumping from Scenario 8 described above, and all recommended and alternative water management strategies. Scenarios 10 to 12 simulated reductions in all Wilcox Aquifer strategies as a means to understand the interaction between the Wilcox and the overlying Carrizo Aquifer. Discussion of the results of these simulations was held at a GMA 13 meeting on January 22, 2016.

Additional discussion of the effects of Scenarios 9 to 12 on the outcrop area are summarized in Technical Memorandum 16-02, which was reviewed at the GMA 13 meeting on February 25, 2016. In response to comments, further investigation of the outcrop area was covered in Technical Memorandum 16-03, and was discussed at the GMA 13 meeting on March 30, 2016. Much of the discussion focused on the limitations of the GAM in simulating the reduction in groundwater storage in the outcrop area.

Finally, Technical Memorandum 16-08 summarizes the drawdown and outcrop results for Scenario 9, which was the basis for the proposed desired future condition. In summary, Scenario 9 included all the future pumping of Scenario 8 plus all recommended and alternative water management strategies in the 2015 Region L plan.

5.3 Hydrologic Conditions within Groundwater Management Area 13

As required by statute, the groundwater conservation districts in Groundwater Management Area 13 considered total estimated recoverable storage, average annual recharge, inflows, and discharge prior to adopting a proposed desired future condition.

5.3.1 Total Estimated Recoverable Storage

As required by statute, the Texas Water Development Board provided the groundwater conservation districts in Groundwater Management Area 13 with estimates of total recoverable storage (Wade and Bradley, 2013). This report is included as Appendix E.

The estimate of total recoverable storage may be a measure of “physical” availability, but is less meaningful in an analysis of groundwater availability as defined by Chapter 36 of the Water Code, and should be viewed with caution. The groundwater availability developed after following the process in Chapter 36 involves consideration of many factors, some technical and some policy-based. In addition, the Texas water Code Sec. 36.108(d-2) states: “*The desired future condition proposed under Subsection (d) must provide a balance between the highest practicable level of groundwater production and the conservation, preservation, protection, recharging, and prevention of waste of groundwater and control of subsidence in the management area*”. This balancing test illustrates how the total estimated recoverable storage value is by itself meaningless in an analysis of groundwater availability.

As calculated, the TWDB estimated recoverable storage represents the approximate fraction of total storage in the aquifer that is in the producing zones (e.g. sands), not what is “recoverable”. Therefore, in most cases, the total estimated recoverable storage is far greater than the highest practicable level of groundwater production.

In addition to the TWDB total recoverable storage report, GMA 13 received a report from a stakeholder regarding selection of DFCs based on use of an acceptable amount of water from aquifer storage through time. A copy of this report is included in Appendix F. The stakeholder followed up on the report with a presentation at the GMA 13 meeting on November 21, 2013. The report in general made a case against GMA 13’s current use of drawdown as a DFC and provided an alternative approach founded on changes in aquifer storage or the protection of unique hydrologic features or conditions. This concept was rejected by GMA 13 for several reasons:

- The presentation inaccurately implied that the DFC adopted in 2010 by GMA 13 are arbitrary and were used to limit impacts on exiting users. It also implied that model runs reflect relatively arbitrary model pumpage inputs and that individual groundwater projects were not included in the DFC model.
- The author failed to explain how choosing an aquifer drawdown limit through time is considered arbitrary but choosing an acceptable amount of water in aquifer storage through time is not arbitrary.
- The author stated that artesian pressure declines do not have a meaningful impact on aquifer storage or groundwater flows to surface features and are, therefore, not suitable as DFCs in those respects. GMA 13 generally agrees with this statement; however, artesian pressure declines are important management tools in dipping confined aquifers where pumpage of non-renewable “fossil” groundwater resources occur. It is important to distinguish renewable from non-renewable or “fossil” groundwater. Groundwater pumpage of renewable resources is limited by fluxes or recharge rates, whereas pumpage of non-renewable resources is limited by groundwater storage.
- The author states that managing aquifer storage makes sense because it can be verified

Desired Future Condition Explanatory Report (Final)
Carrizo-Wilcox/Queen City/Sparta Aquifers for Groundwater Management Area 13

easily and inexpensively through monitoring of the water table levels. However, the accuracy of assessing aquifer storage amounts through monitoring of water table levels is actually rather complex whereas assessing water table drawdown levels is simple and straight forward.

5.3.2 Average Annual Recharge, Inflows and Discharge

Although not specifically required in 2010 as it is now, during the development of the existing desired future condition for the Carrizo-Wilcox, Queen City, and Sparta aquifers in 2010, the groundwater conservation districts in Groundwater Management Area 13 considered the historic groundwater budget for GMA 13 as a management unit, and considered the simulated water budget in 2060 for each groundwater conservation district (or county where a groundwater conservation district did not exist) for four alternative scenarios. The information on these water budget comparisons were provided in a PowerPoint presentation at the Groundwater Management Area 13 meeting on February 19, 2010, and in GAM Report 09-034 (Wade and Jigmond, 2010). This information was presented again during the development of this desired future condition.

The groundwater budgets for Groundwater Management Area 13 based on the updated calibration period (2000 to 2011) and Scenario 9 (the basis for the desired future condition) calibrated are summarized in Table 2.

**Table 2. Groundwater Budget for Groundwater Management Area 13
(all values in AF/yr)**

Inflow	Average 2000- 2011	Scenario 9 (2070)
River and Stream	52,989	110,881
Recharge	206,736	203,106
From Mexico	17	13
GHB	0	15,568
From GMA 10	1,214	1,238
From GMA 12	329	40,744
From GMA 15	0	34,379
From GMA 16	1,034	5,073
Total Inflow	262,321	411,002
Outflow		
Wells	321,056	609,376
Drains	1,420	521
ET	9,208	7,907
GHB	4,733	0
To GMA 15	5,276	0
Total Outflow	341,692	617,804
Inflow-Outflow	-79,371	-206,802
Storage Change	-79,318	-206,747
Model Error	-54	-55

Table 1 shows that pumping would increase from about 320,000 AF/yr in 2000 to 2011 to about 610,000 AF/yr in 2070, about a 290,000 AF/yr increase. About 44 percent of this pumping would come from reduced storage (about 127,000 AF/yr). The pumping would also come from surface water baseflow depletions (about 58,000 AF/yr or about 20 percent of the pumping), and from induced inflows from bordering GMAs (about 75,000 AF/yr from GMAs 12 and 15, or about 28 percent of the pumping).

The pumping increase is mostly in the downdip areas of GMA 13, and the impacts to surface water would be in the outcrop areas. There are several downdip wells in GMA 13 that are near the outcrop/downdip boundary that have the potential to affect the outcrop area. This wells are distinct from the wells that are located several miles downdip from the boundary in terms of potential impacts to surface water flows.

The GAM is not necessarily calibrated to a degree where surface water impacts are particularly reliable or can be viewed as quantitative. However, the GAM is the best tool to address this factor. Since the GAM is an imperfect tool, the conclusion of this analysis is that the increased pumping will cause impacts in addition to reduction in storage.

5.4 Other Environmental Impacts, Including Spring Flow and Other Interactions between Groundwater and Surface Water

The evaluation of all water budget components was discussed in Section 5.3.2 above.

Guadalupe Blanco River Authority submitted a letter on February 24, 2016 to Groundwater Management Area 13 that expressed a concern about the cumulative effects of the Carrizo-Wilcox pumpage from the 2016 South Central Regional Water Plan (GAM Simulation Scenario 9) on the potential reduction in streamflow and adverse effects on surface water rights and environmental flows in the Guadalupe and San Antonio River Basins, as well as fresh water inflows to the Guadalupe Estuary.

5.5 Subsidence

Subsidence has not been an issue historically in these aquifers.

5.6 Socioeconomic Impacts

The Texas Water Development Board prepared reports on the socioeconomic impacts of not meeting water needs for each of the Regional Planning Groups during development of the 2011 Regional Water Plans. Because the development of this desired future condition used the State Water Plan demands and water management strategies as an important foundation, it is reasonable to conclude that the socioeconomic impacts associated with this proposed desired future condition can be evaluated in the context of not meeting the listed water management strategies. Groundwater Management Area 13 is covered by Regional Planning Groups L and M. In addition, there is an important water management strategy that is sourced in Gonzales County to meet demands in Regional Planning Group K. The socioeconomic impact reports for Regions K, L, and M are included in Appendix G.

Socioeconomic Impacts to local landowners due to development of water management strategies within GMA 13 must also be taken into account. The Texas Water Development Board is not tasked with preparing reports on the socioeconomic impacts to local landowners, therefore this information must come from the local groundwater districts. There are two groundwater mitigation projects currently on-going in the GMA 13 area. One is operated by the Gonzales County Underground Water Conservation District (GCUWCD) and the other is operated by the San Antonio Water System in an area just outside of GMA 13.

Economic impacts to the local landowners to date can be estimated from one of these mitigation projects. The GCUWCD mitigation project began in 2011 and has spent more than \$1,124,000 to date to mitigate the effects of pumpage from large-scale water management strategies. Per well mitigation costs to lower pumps or re-drill water wells deeper has ranged from about \$4,200 to

\$28,000.

5.7 Impact on Private Property Rights

The impact on the interests and rights in private property, including ownership and the rights of landowners and their lessees and assigns in Groundwater Management Area 13 in groundwater is recognized under Texas Water Code Section 36.002.

The desired future conditions adopted by GMA 13 are consistent with protecting property rights of landowners who are currently pumping groundwater and landowners who have chosen to conserve groundwater by not pumping. All current and projected uses (as defined in the 2015 Region L plan) were included in Scenario 9 (the basis for the desired future condition). The increase in pumping associated with meeting the Region L water management strategies will cause impacts to exiting well owners and to surface water. However, as required by Chapter 36 of the Water Code, GMA 13 considered these impacts and balanced them with the increasing demand of water in the GMA 13 area, and concluded that, on balance and with appropriate monitoring and project specific review during the permitting process, all the Region L strategies can be included in the desired future condition.

5.8 Feasibility of Achieving the Desired Future Condition

Groundwater levels are routinely monitored by the districts and by the TWDB in GMA 13. Evaluating the monitoring data is a routine task for the districts, and the comparison of these data with the desired future condition and model results that were used to develop the DFCs is covered in each district's management plan. These comparisons will be useful to guide the update of the DFCs that are required every five years.

5.9 Other Information

The process to develop the proposed desired future conditions at numerous GMA 13 meetings from 2013 to 2016 included submitted materials and presentations at the meetings, as well as detailed discussion during the meetings.

James Bene of R.W. Harden & Associates submitted a paper on September 20, 2013 to Groundwater Management Area 13 that discussed the joint planning process. This paper provided one perspective on how to develop desired future conditions. The paper made several points that were used in the development of this proposed desired future condition as discussed in Section 5.3.1 of this report, and, as stated above, is included in this report as Appendix F.

James Bene of R.W. Harden & Associates gave a presentation at the November 21, 2013 Groundwater Management Area 13 meeting on potential alternative DFCs. A copy of this presentation is included as Appendix H.

Desired Future Condition Explanatory Report (Final)
Carrizo-Wilcox/Queen City/Sparta Aquifers for Groundwater Management Area 13

Guadalupe Blanco River Authority submitted a letter on February 24, 2016 to Groundwater Management Area 13 that expressed a concern about the cumulative effects of the Carrizo-Wilcox pumpage from the 2016 South Central Regional Water Plan (GAM Simulation Scenario 9) on the potential reduction in streamflow and adverse effects on surface water rights and environmental flows in the Guadalupe and San Antonio River Basins, as well as fresh water inflows to the Guadalupe Estuary. This letter is included as Appendix I.

James Beach of LBG-Guyton Associates gave a presentation at the March 30, 2016 Groundwater Management Area 13 meeting on modeling groundwater-surface water interaction. A copy of this presentation is included as Appendix J.

6.0 Discussion of Other Desired Future Conditions Considered

There were 14 scenarios and a total of 51 GAM simulations completed as part of the development of the desired future conditions. Results of these simulations were presented at GMA 13 meetings and in technical memoranda as follows:

- Scenarios 1 to 7 were a collection of initial runs that began with a base case (Scenario 4) based on pumping input from the groundwater conservation districts in GMA 13. Scenarios 1 to 3 were incremental reductions in Scenario 4 pumping, and Scenarios 4 to 7 represented incremental increases in Scenario 4 pumping. These results were discussed at the GMA 13 meeting of October 13, 2013.
- Scenario 8 was based on modifications to Scenario 4 based on input from the groundwater conservation districts (notably Gonzales UWCD and Guadalupe County GCD). Results of Scenario 8 were discussed at the March 13, 2014 GMA 13 meeting
- Scenario 9 was developed to comprehensively consider all recommended and alternative water management strategies, and was ultimately used as the basis for the desired future conditions. The initial results were summarized in Technical Memorandum 16-01 and were discussed at the January 22, 2016 GMA 13 meeting.
- A more detailed analysis of the outcrop area results from Scenario 9 is summarized in Technical Memorandum 16-02, and was discussed at the February 25, 2016 GMA 13 meeting.
- Scenarios 13 and 14 were completed to further evaluate the concept of maintaining threshold saturation in the outcrop area. These scenarios involved completing 34 simulations (18 simulations in Scenario 13 and 16 simulations in Scenario 14). Results were summarized in Technical Memorandum 16-03 and discussed at the March 30, 2016 GMA 13 meeting.
- Technical Memorandum 16-08 was developed to summarize the results of Scenario 9 in a single document since the results had been previously covered in multiple memoranda and discussed at several meetings.

As discussed earlier, desired future conditions based solely on storage without consideration of the impacts of increased pumping were not considered feasible because such an approach ignores other statutory factors.

7.0 Discussion of Other Recommendations

Public comments were invited and each district held a public hearing on the proposed desired future condition as follows:

Groundwater Conservation District	Date of Public Hearing	Number of Comments Received
Evergreen UWCD	July 28, 2016	0
Gonzales County UWCD	June 14, 2016	3 oral, 5 written
Guadalupe County GCD	June 6, 2016	0
McMullen GCD	June 23, 2016	0
Medina County GCD	June 15, 2016	0
Plum Creek CD	June 21, 2016	0
Uvalde County UWCD	June 14, 2016	0
Wintergarden GCD	August 1, 2016	0

Many of the comments from Gonzales County UWCD did not specifically address the proposed desired future condition. Rather, many of the comments focused on the importance of some of the factors that should be considered. Indeed, much of the discussion at GMA 13 meetings and the simulation results were discussed in the context of the factors, and, through that discussion, the importance of the factors on the process was evaluated.

There were two written comments that recommended that the desired future condition not be changed. This had also been discussed early in the process and was rejected after considering the regional planning water management strategies. If the desired future condition were to remain unchanged, there would be impacts on the ability of the region to meet its future water demands as defined by the Region L water plan.

8.0 References

- Deeds, N., Kelley, V., Fryar, D., Jones, T., Whallon, A. J., and Dean, K. E., 2003, Groundwater Availability Model for the Southern Carrizo-Wilcox Aquifer: contract report to the Texas Water Development Board, 452 p.
- Hutchison, W.R., Comparison of Groundwater Monitoring Data with Groundwater Model Results, Groundwater Management Area 13. Contracted report for Groundwater Management Area 13, 178 p.
- Kelley, V. A., Deeds, N. E., Fryar, D. G., and Nicot, J. P., 2004, Groundwater availability models for the Queen City and Sparta aquifers: contract report to the Texas Water Development Board, 867 p.
- Nicot, J-P, Reedy, R.C., Costley, R.A., and Huang, Y., 2012. Oil & Gas Water Use in Texas: Update to the 2011 Mining Water Use Report. Bureau of Economic Geology, Jackson School of Geosciences, The University of Texas at Austin. Report prepared for Texas Oil & Gas Association, Austin, Texas.
- Wade, S. and Bradley, R., 2013, GAM Task 13-036 (Revised): Total Estimated Recoverable Storage for Aquifers in Groundwater Management Area 13. Texas Water Development Board GAM Task Report, 30 p.
- Wade, S. and Jigmond, M., 2010. GAM Run 09-034, Texas Water Development Board GAM Run Report, 146 p.

Appendix A
Proposed Desired Future Condition Resolution

Groundwater Management Area 13 Resolution 16-01

Desired Future Conditions for the Carrizo-Wilcox, Queen City, and Sparta Aquifers in Groundwater Management Area 13

WHEREAS, Groundwater Conservation Districts (GCDs) located within or partially within Groundwater Management Area 13 (GMA 13) are required under Chapter 36.108, Texas Water Code to conduct joint planning and designate the Desired Future Conditions of aquifers within GMA 13 and;

WHEREAS, the Board Presidents or their Designated Representatives of GCDs in GMA 13 have met in various meetings and conducted joint planning in accordance with §36.108, Texas Water Code since September 2010; and

WHEREAS, the GMA 13 committee has received and considered Groundwater Availability Model runs and other technical advice regarding local aquifers, hydrology, geology, recharge characteristics, the nine factors set forth in §36.108(d) of the Texas Water Code, local groundwater demands and usage, population projections, total water supply and quality of water supply available from all aquifers within the respective GCDs, regional water plan water management strategies, ground and surface water interactions, that affect groundwater conditions through the year 2070; and

WHEREAS, the member GCDs of GMA 13, having given proper and timely notice, held an open meeting on April 27, 2016 at the offices of the Evergreen Underground Water Conservation District located at 110 Wyoming Blvd., Pleasanton, Texas, to vote to adopt proposed Desired Future Conditions for the Carrizo-Wilcox, Queen City, and Sparta aquifers within the boundaries of GMA 13; and

WHEREAS, the member GCDs in which the Carrizo-Wilcox, Queen City, and Sparta aquifers are relevant for joint planning purposes held open meetings within each said district between June 6, 2016 and August 1, 2016 to take public comment on the proposed DFCs for that district; and

WHEREAS on this day of November 21, 2016 at an open meeting duly noticed and held in accordance with law at the offices of the Evergreen Underground Water Conservation District located at 110 Wyoming Blvd., Pleasanton, Texas, the GCDs within GMA 13, having considered at this meeting comments submitted to the individual districts during the comment period and at this meeting, have voted, __ districts in favor, __ districts opposed, to adopt the following DFCs for in the following counties and districts through the year 2070 as follows:

NOW THEREFORE BE IT RESOLVED, that Groundwater Management Area 13 does hereby document, record, and confirm the above-described Desired Future Conditions for the Carrizo-Wilcox, Queen City, and Sparta Aquifer which were adopted by vote of the following Designated Representatives of Groundwater Conservation Districts present and voting on November 21, 2016:

Due to limitations with the model as described in Technical Memorandum 16-08, two proposed desired future conditions were selected for the Carrizo-Wilcox, Queen City, and Sparta aquifers as described below.

- The first proposed desired future condition for the Carrizo-Wilcox, Queen City and Sparta aquifers in Groundwater Management Area 13 is that 75 percent of the saturated thickness in the outcrop at the end of 2012 remains in 2070. This desired future condition is considered feasible despite model predictions to the contrary as detailed in GMA 13 Technical Memorandum 16-08.
- In addition, a secondary proposed desired future condition for the Carrizo-Wilcox, Queen City, and Sparta aquifers in Groundwater Management Area 13 is an average drawdown of 48 feet for all of GMA 13. The drawdown is calculated from the end of 2012 conditions to the year 2070. This desired future condition is consistent with Scenario 9 as detailed in GMA 13 Technical Memorandum 16-01 and GMA 13 Technical Memorandum 16-08.



For Evergreen Underground Water Conservation District



For Guadalupe County Groundwater Conservation District



For Gonzales County Underground Water Conservation District



For McMullen Groundwater Conservation District



For Medina County Groundwater Conservation District



For Plum Creek Conservation District



For Uvalde County Underground Water Conservation District



For Wintergarden Groundwater Conservation District

Appendix B
Groundwater Use Estimates

1999 from GAM
2000 to 2008 from TWDB WUS

Atascosa County Sparta Aquifer

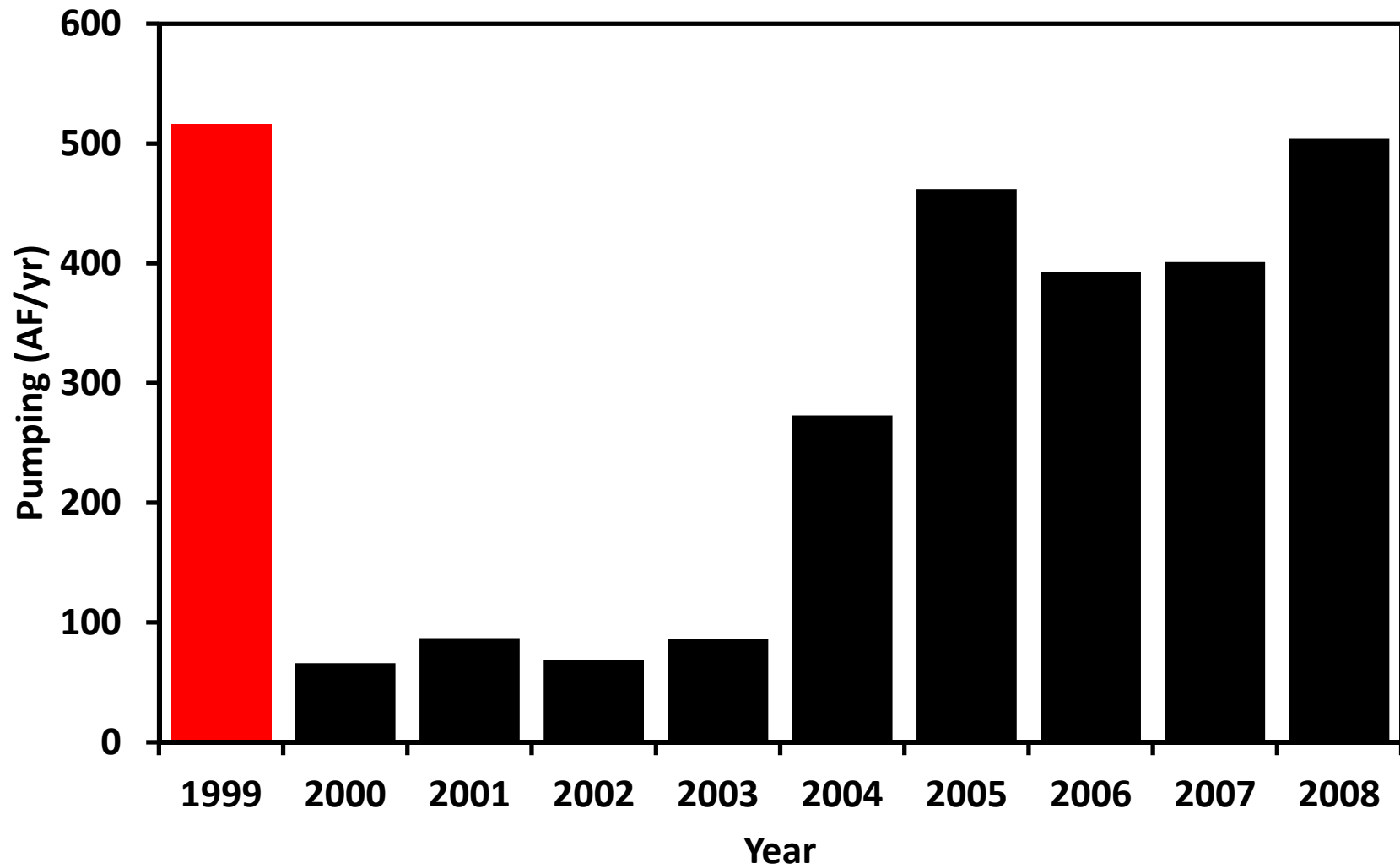

1999 from GAM
2000 to 2008 from TWDB WUS

Frio County Sparta Aquifer

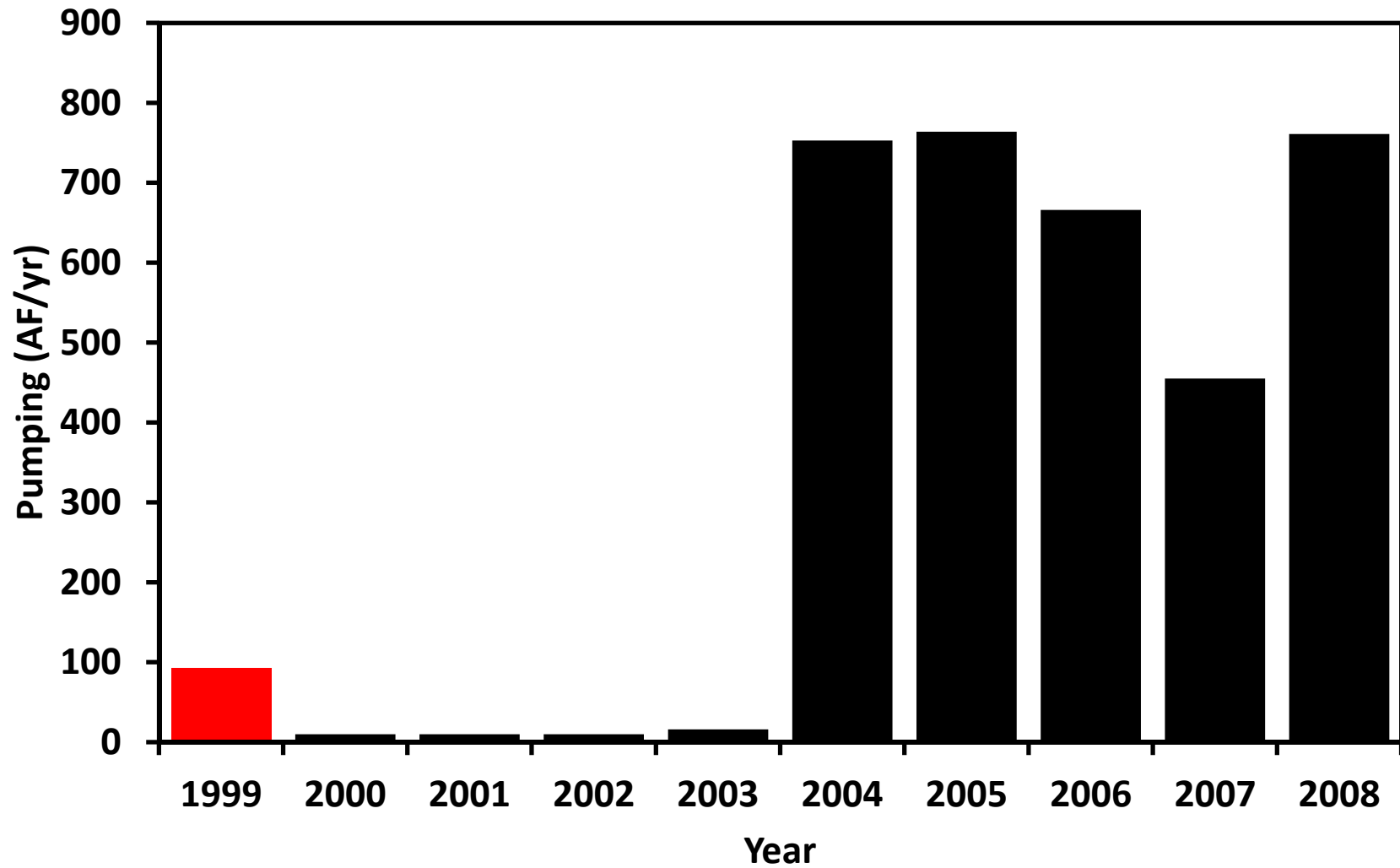

1999 from GAM
2000 to 2008 from TWDB WUS
2000 to 2011 from GCD

Gonzales County Sparta Aquifer

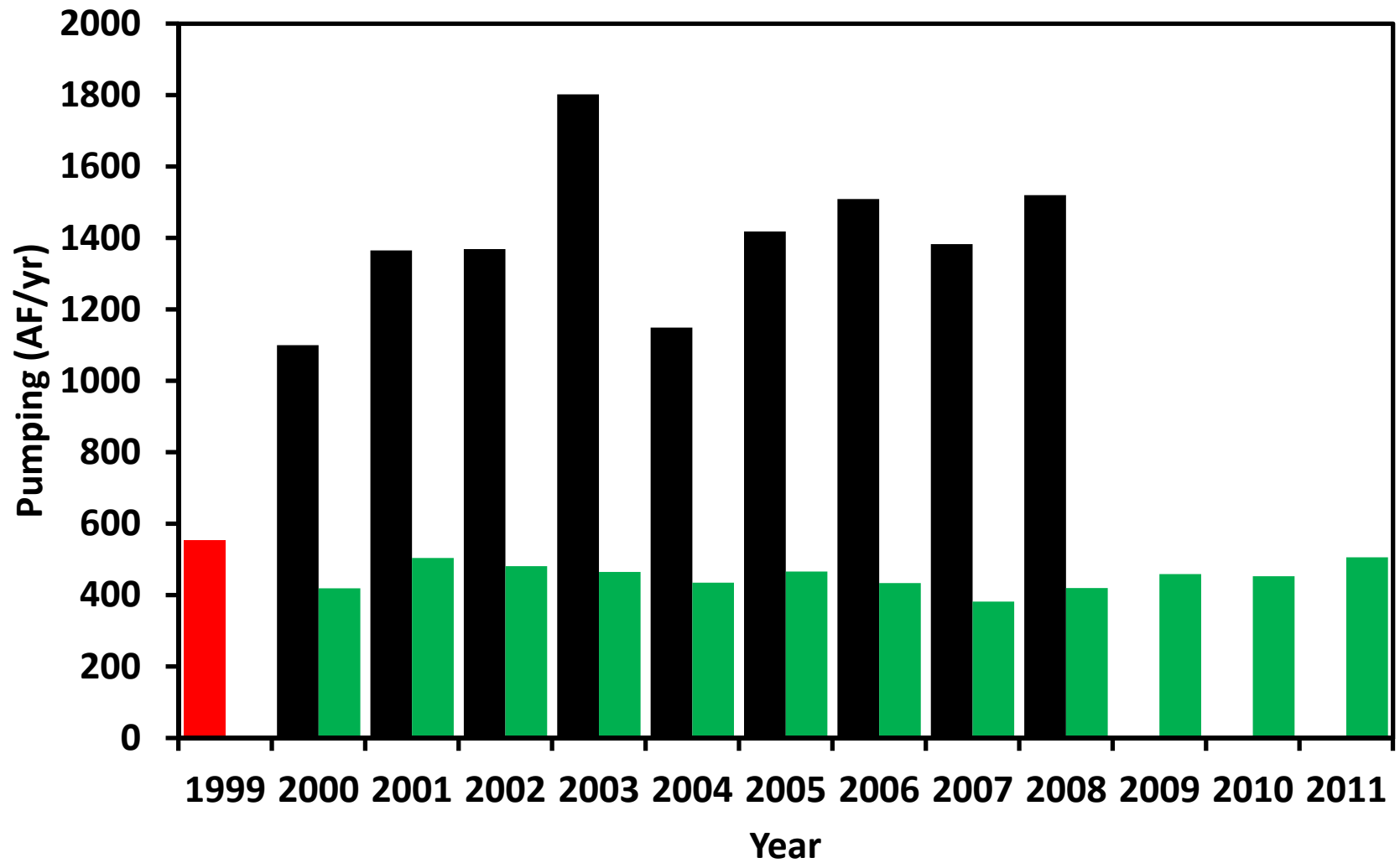

1999 from GAM
2000 to 2008 from TWDB WUS

La Salle County Sparta Aquifer

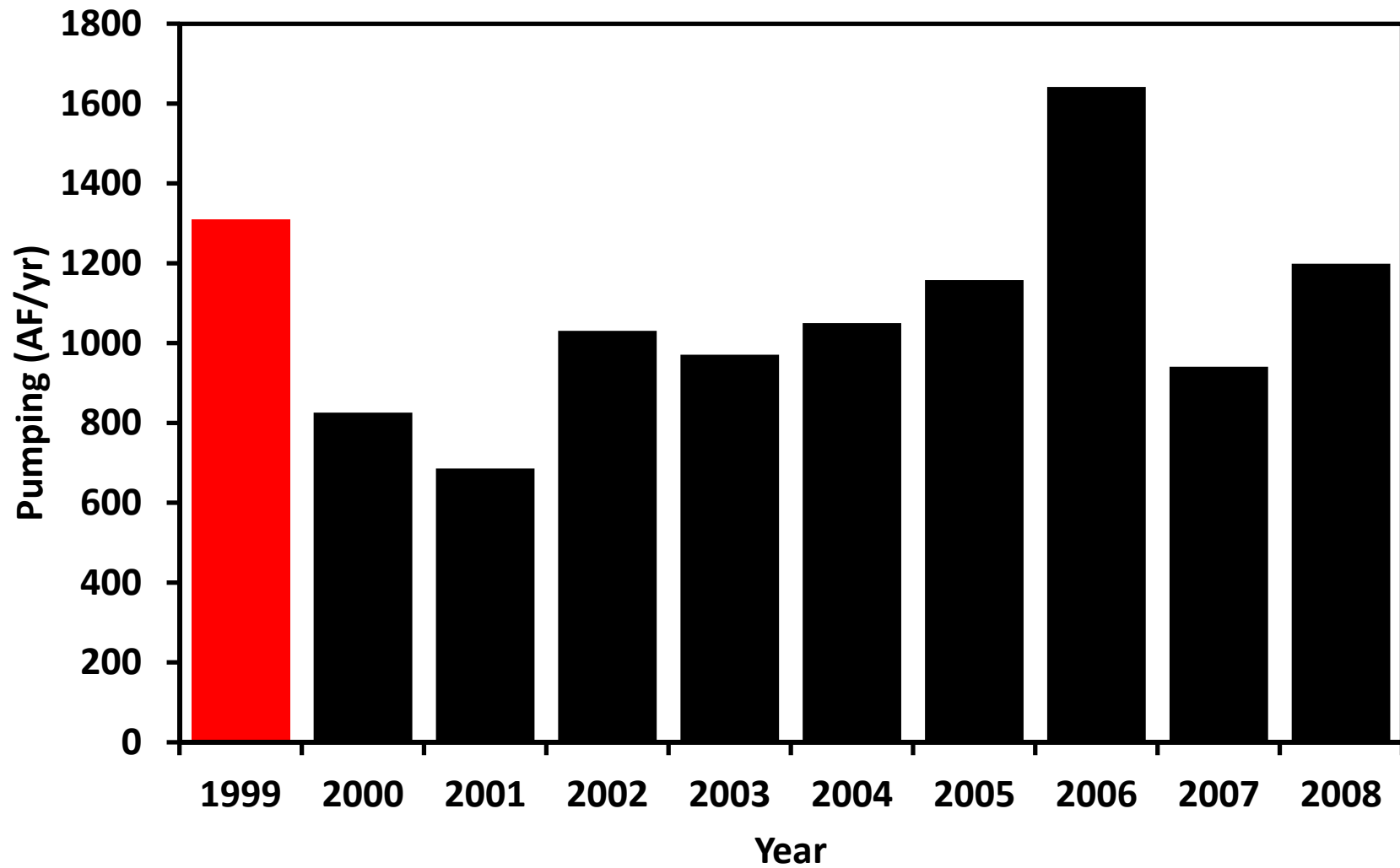

1999 from GAM
2000 to 2008 from TWDB WUS

Wilson County Sparta Aquifer

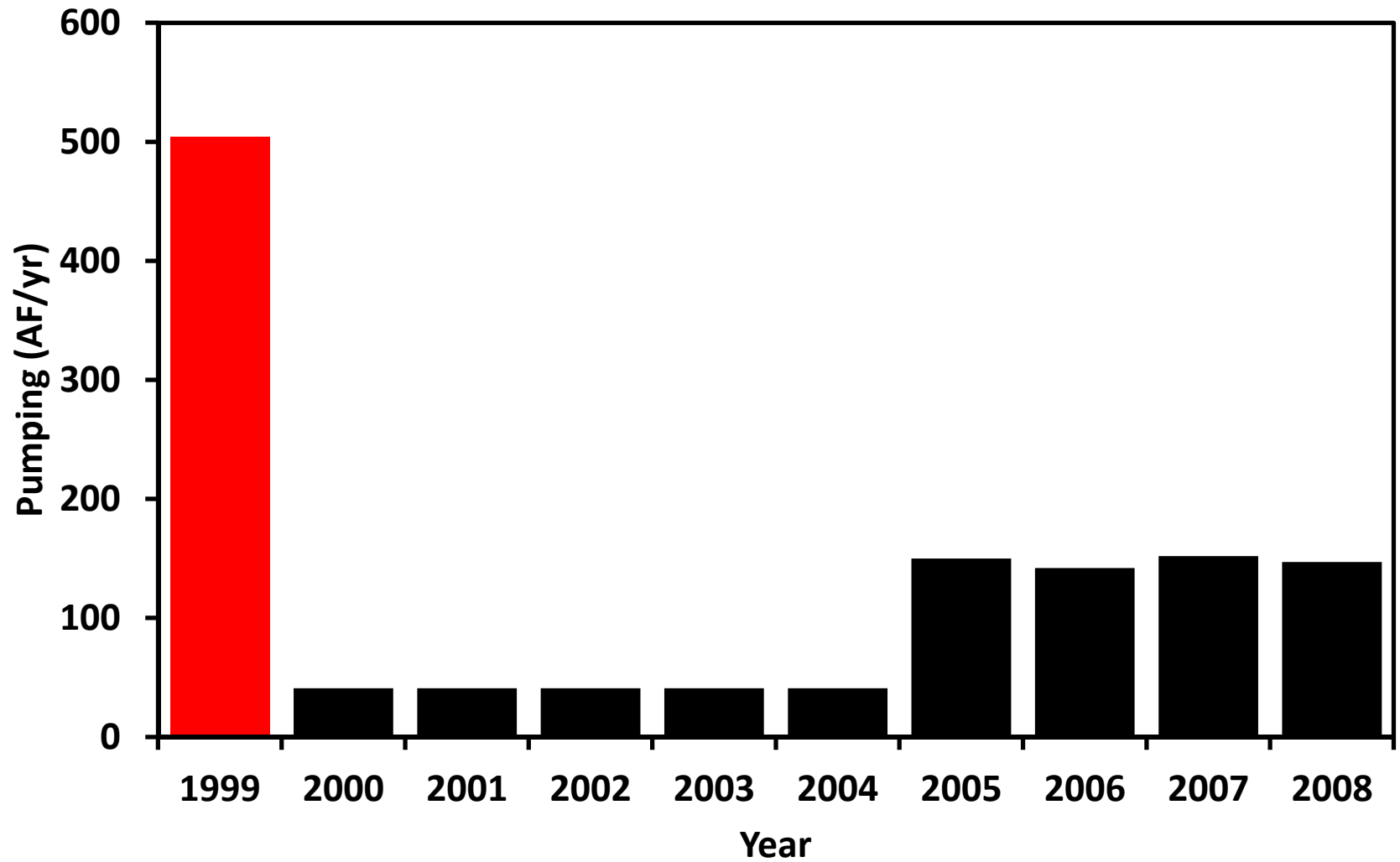

1999 from GAM
2000 to 2008 from TWDB WUS

Atascosa County Queen City Aquifer

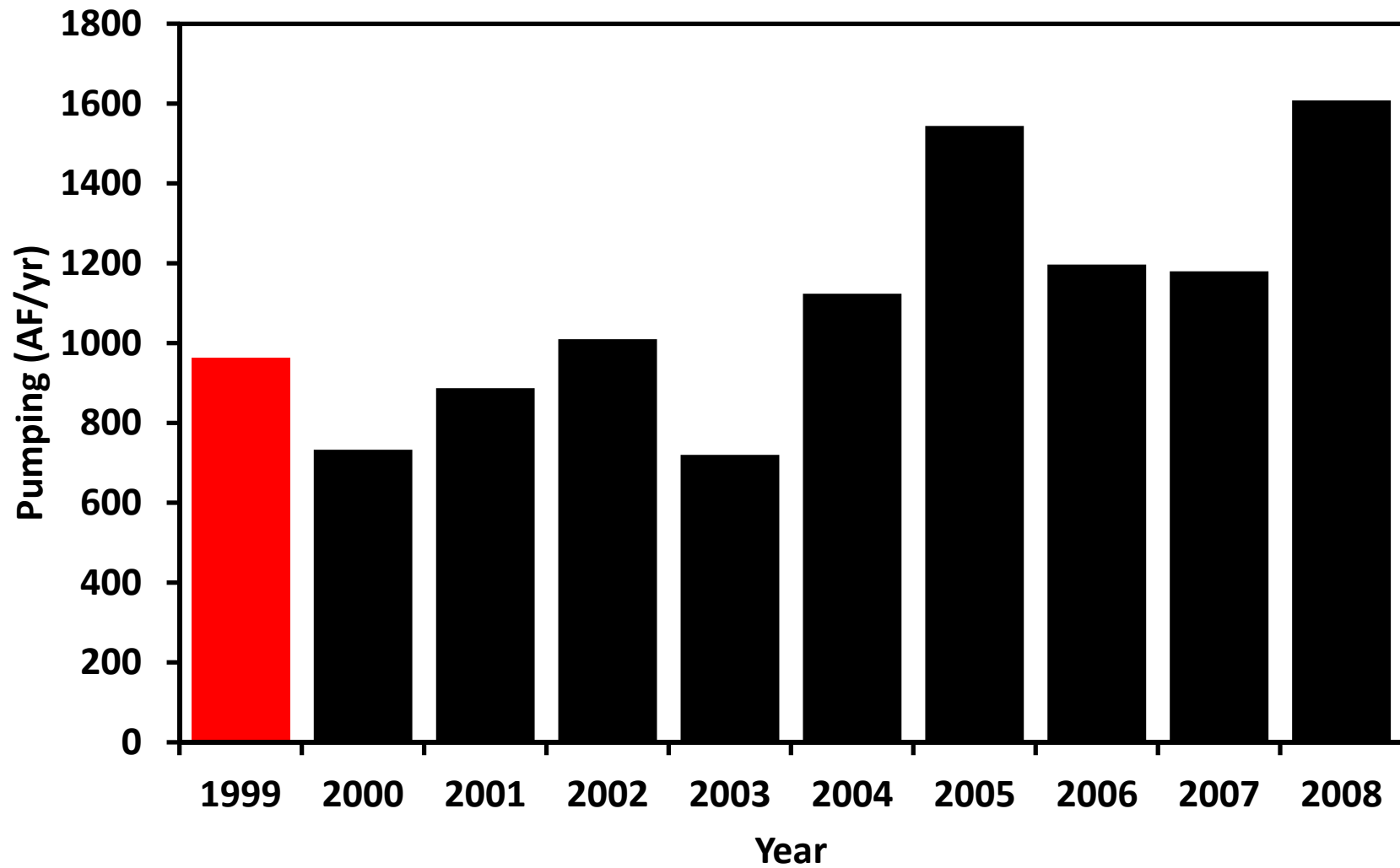

1999 from GAM
2000 to 2008 from TWDB WUS

Caldwell County Queen City Aquifer

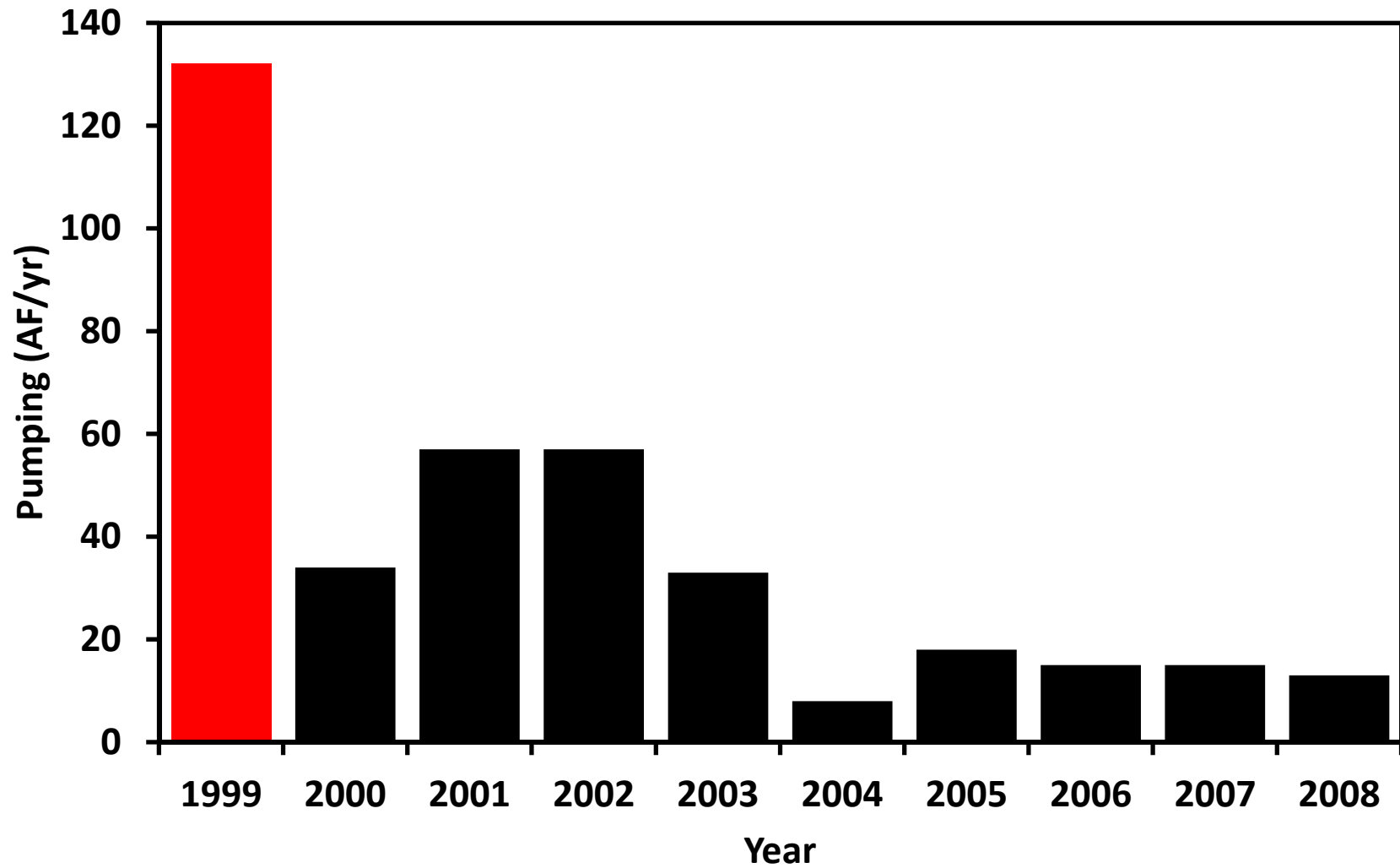

1999 from GAM
2000 to 2008 from TWDB WUS

Frio County Queen City Aquifer

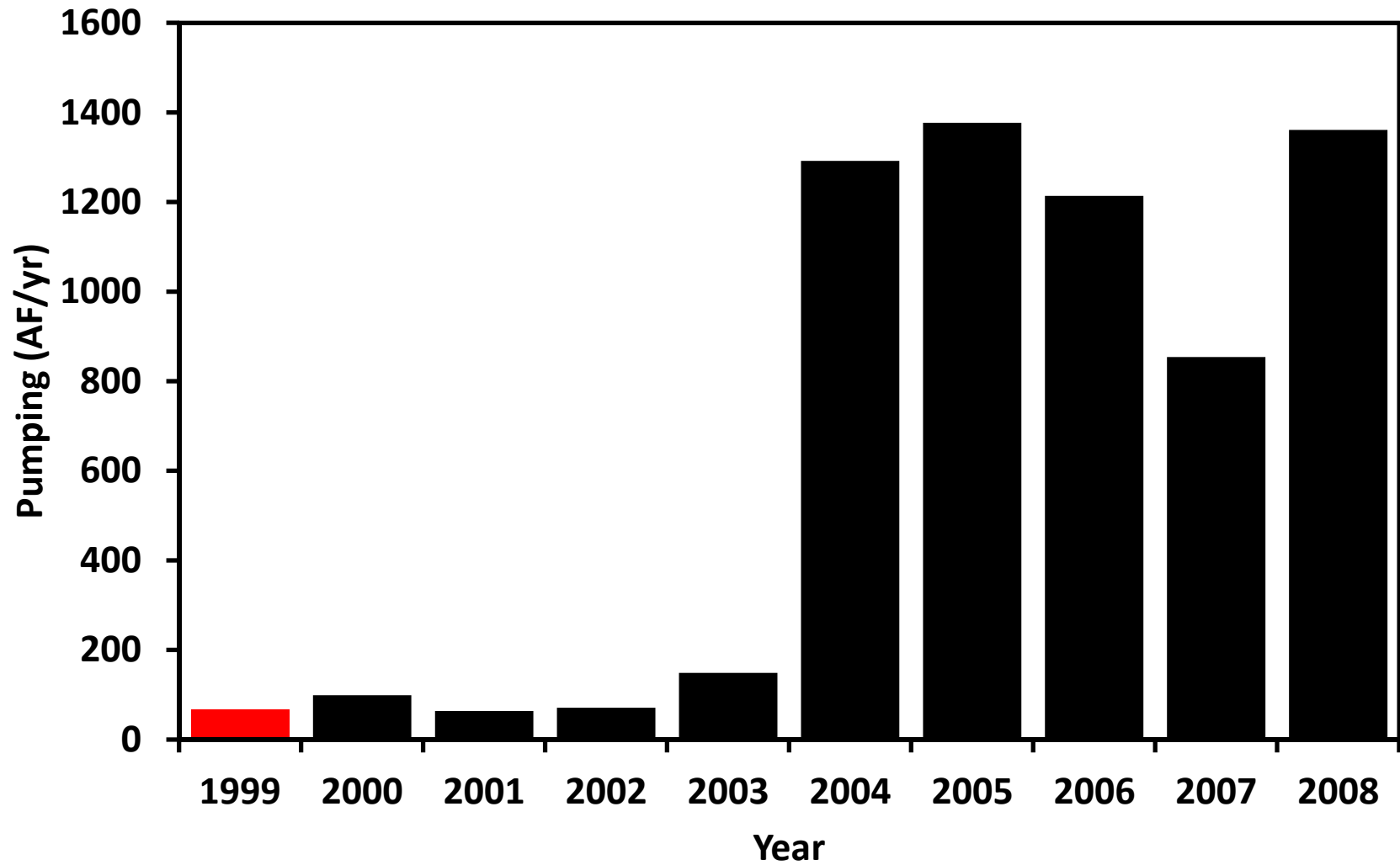

1999 from GAM
2000 to 2008 from TWDB WUS
2000 to 2011 from GCD

Gonzales County Queen City Aquifer

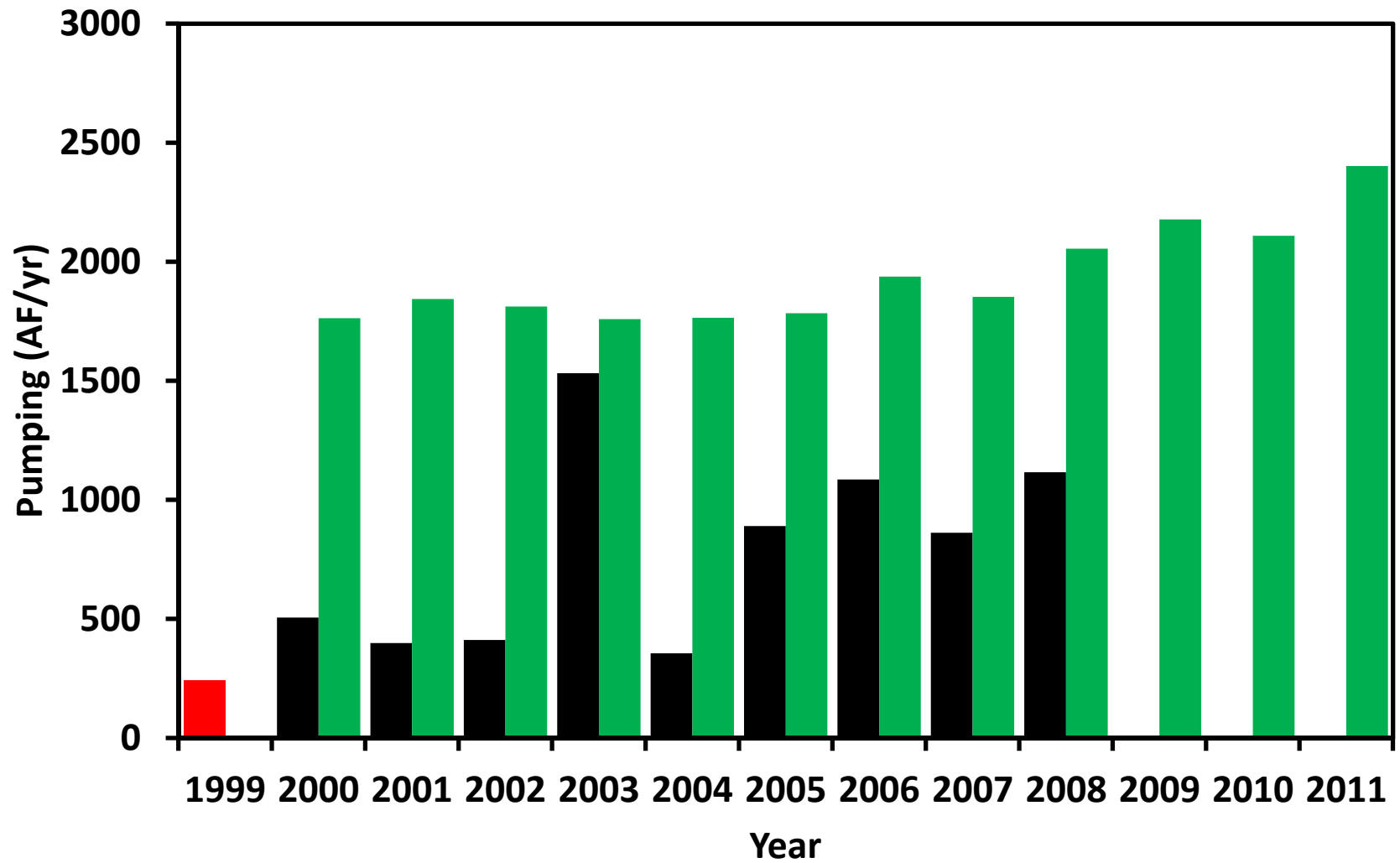

1999 from GAM
2000 to 2008 from TWDB WUS

Wilson County Queen City Aquifer

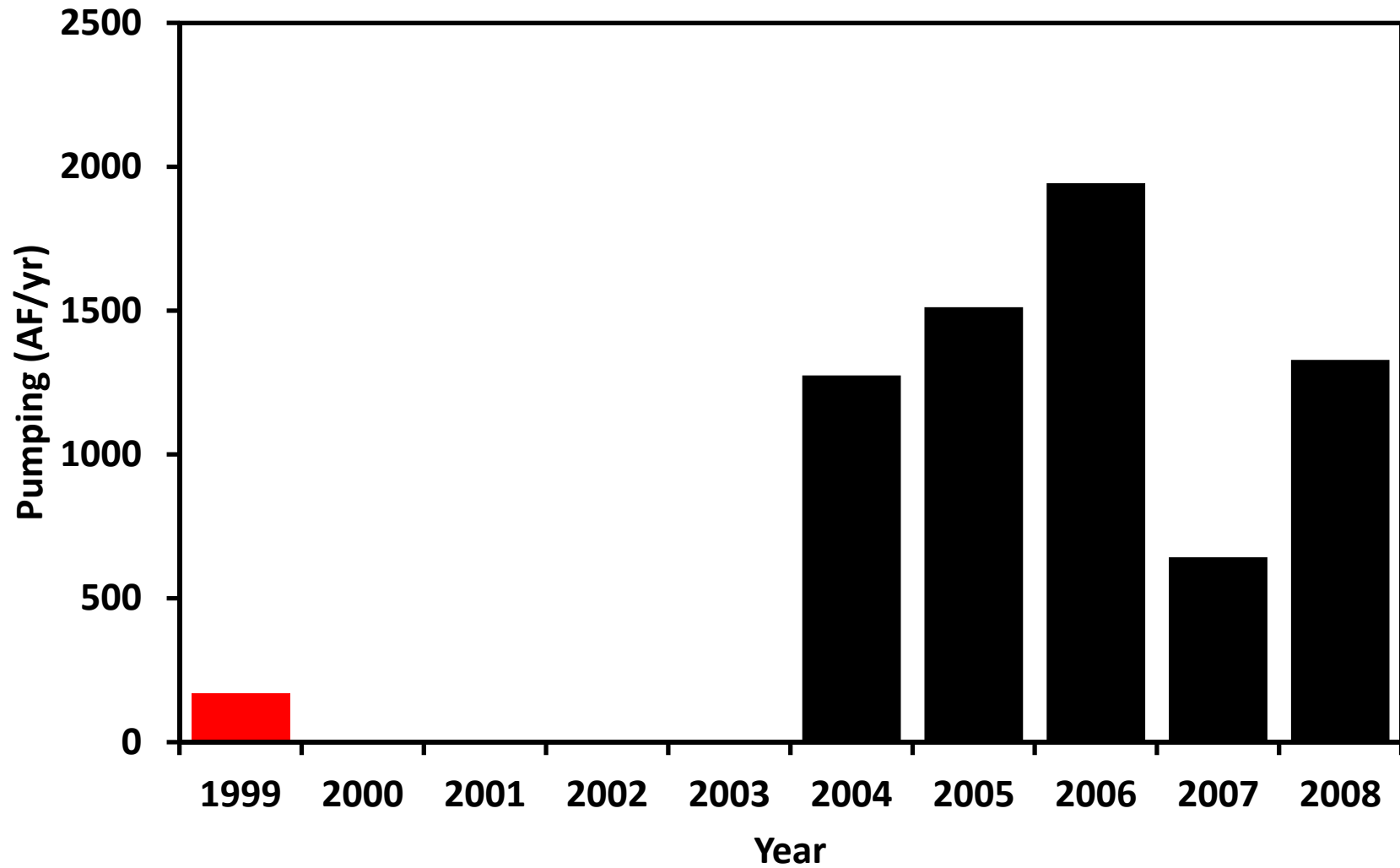

1999 from GAM
2000 to 2008 from TWDB WUS

Atascosa County Carrizo-Wilcox Aquifer

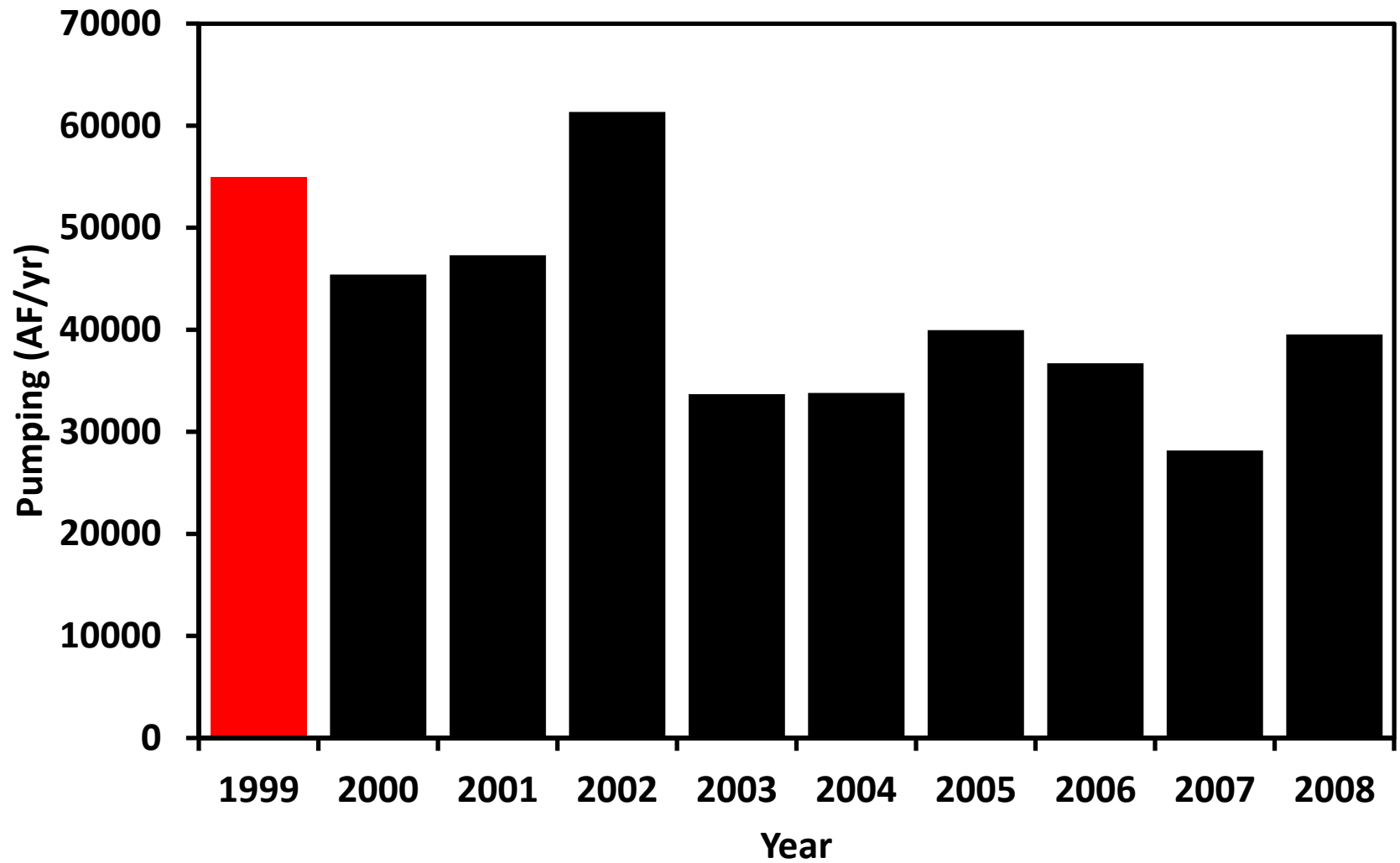

1999 from GAM
2000 to 2008 from TWDB WUS

Bexar County Carrizo-Wilcox Aquifer

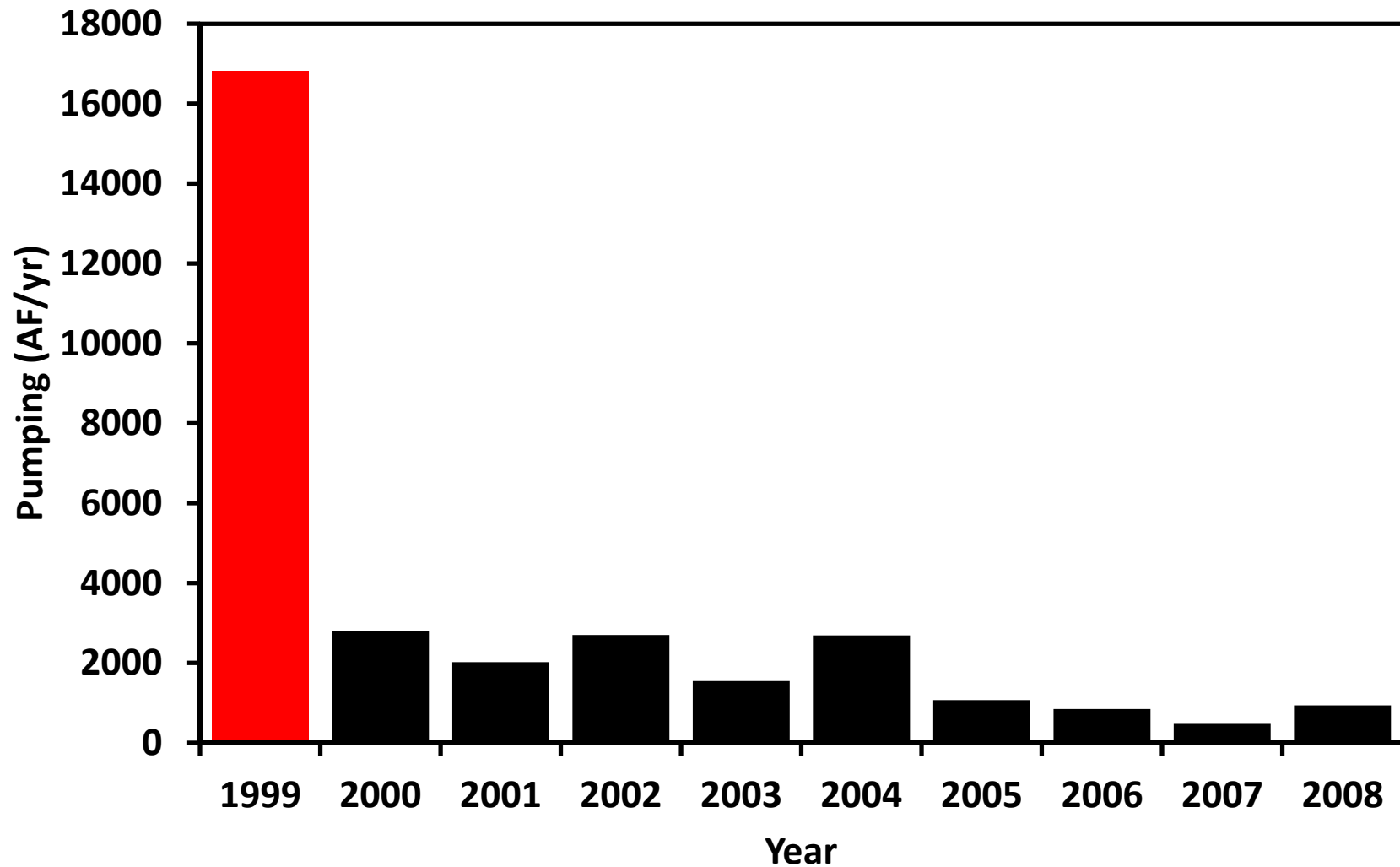

1999 from GAM
2000 to 2008 from TWDB WUS
2000 to 2011 from GCD

Caldwell County Carrizo-Wilcox Aquifer

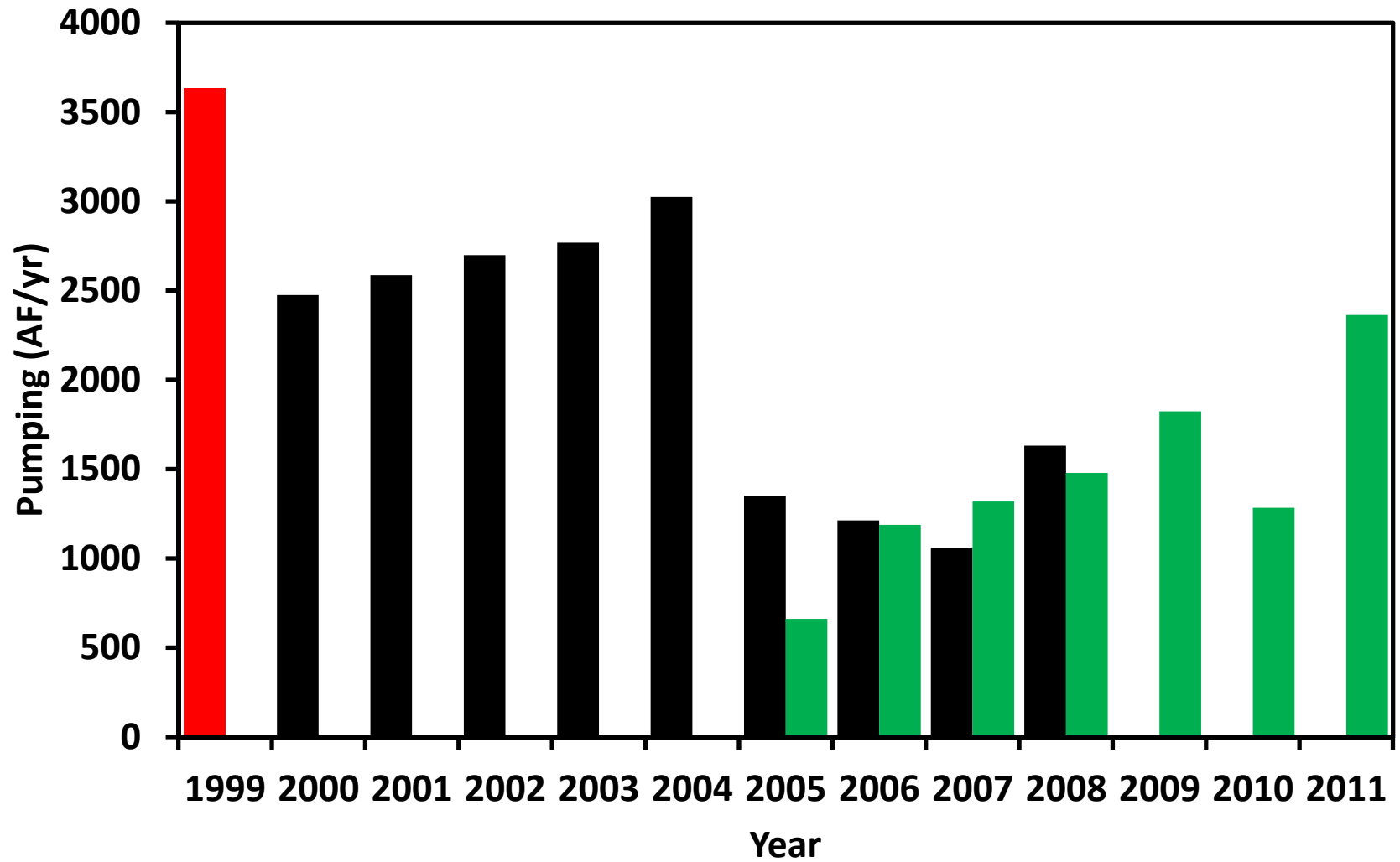

1999 from GAM
2000 to 2008 from TWDB WUS

Dimmit County Carrizo-Wilcox Aquifer

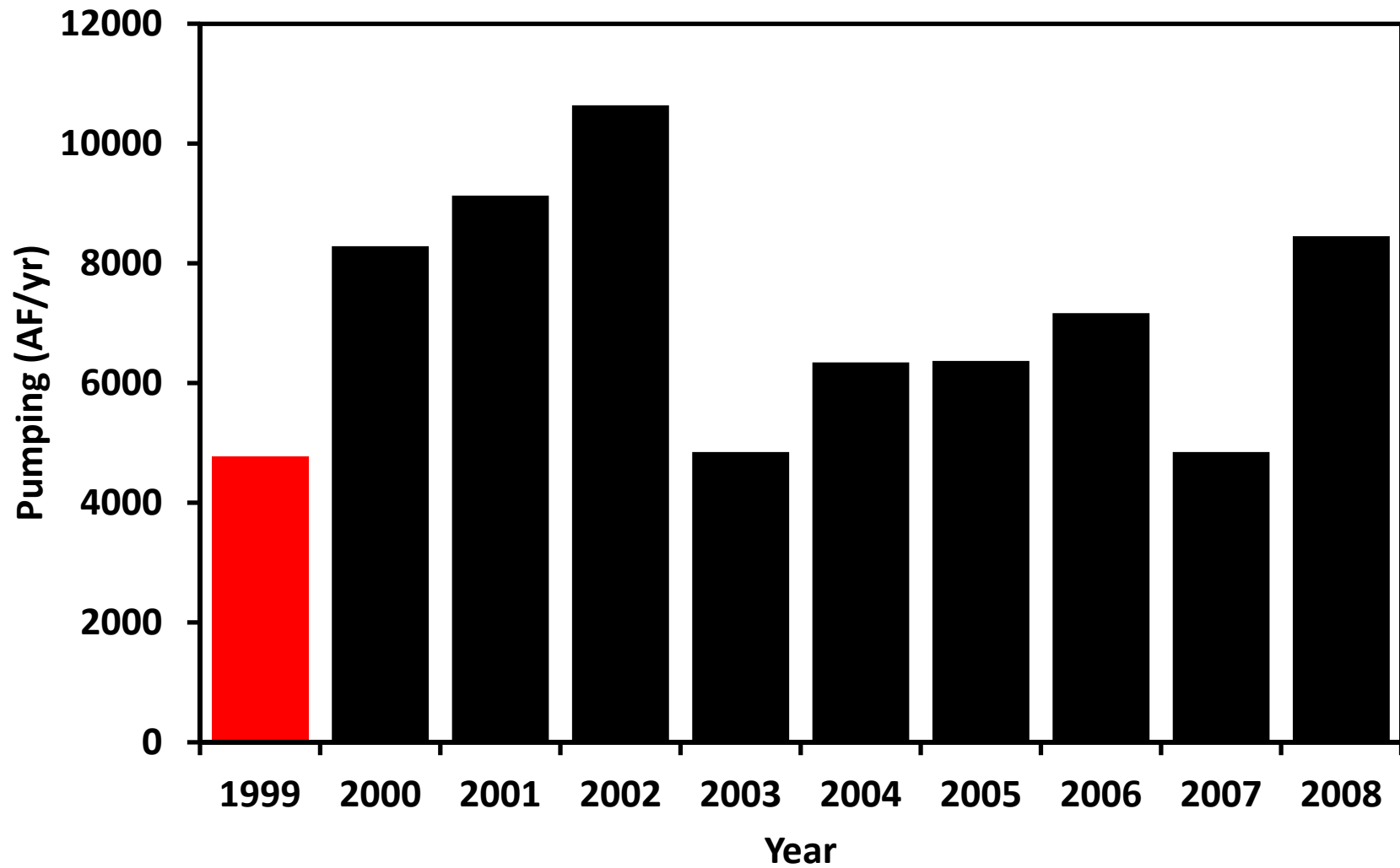

1999 from GAM
2000 to 2008 from TWDB WUS

Frio County Carrizo-Wilcox Aquifer

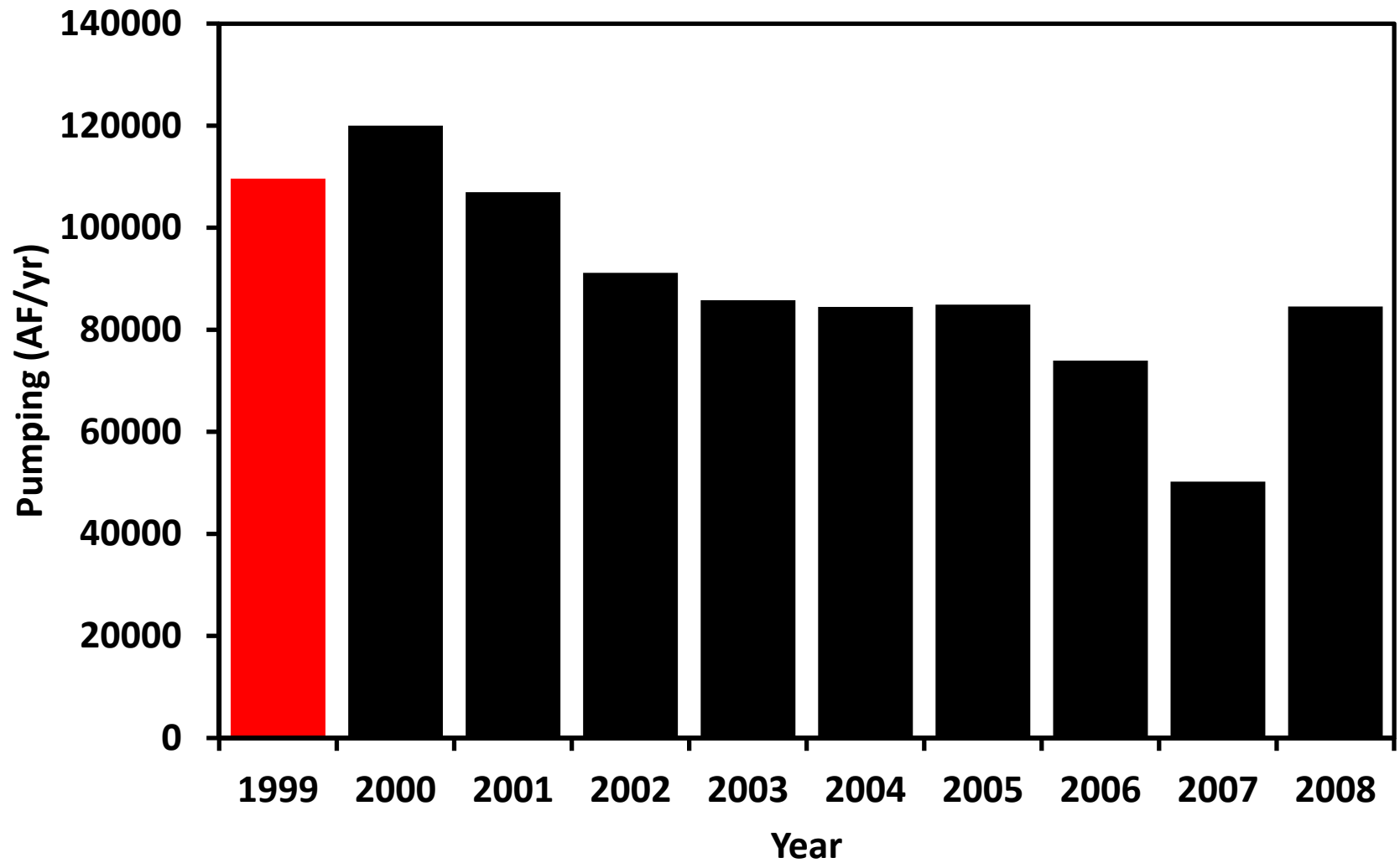

1999 from GAM
2000 to 2008 from TWDB WUS
2000 to 2011 from GCD

Gonzales County Carrizo-Wilcox Aquifer

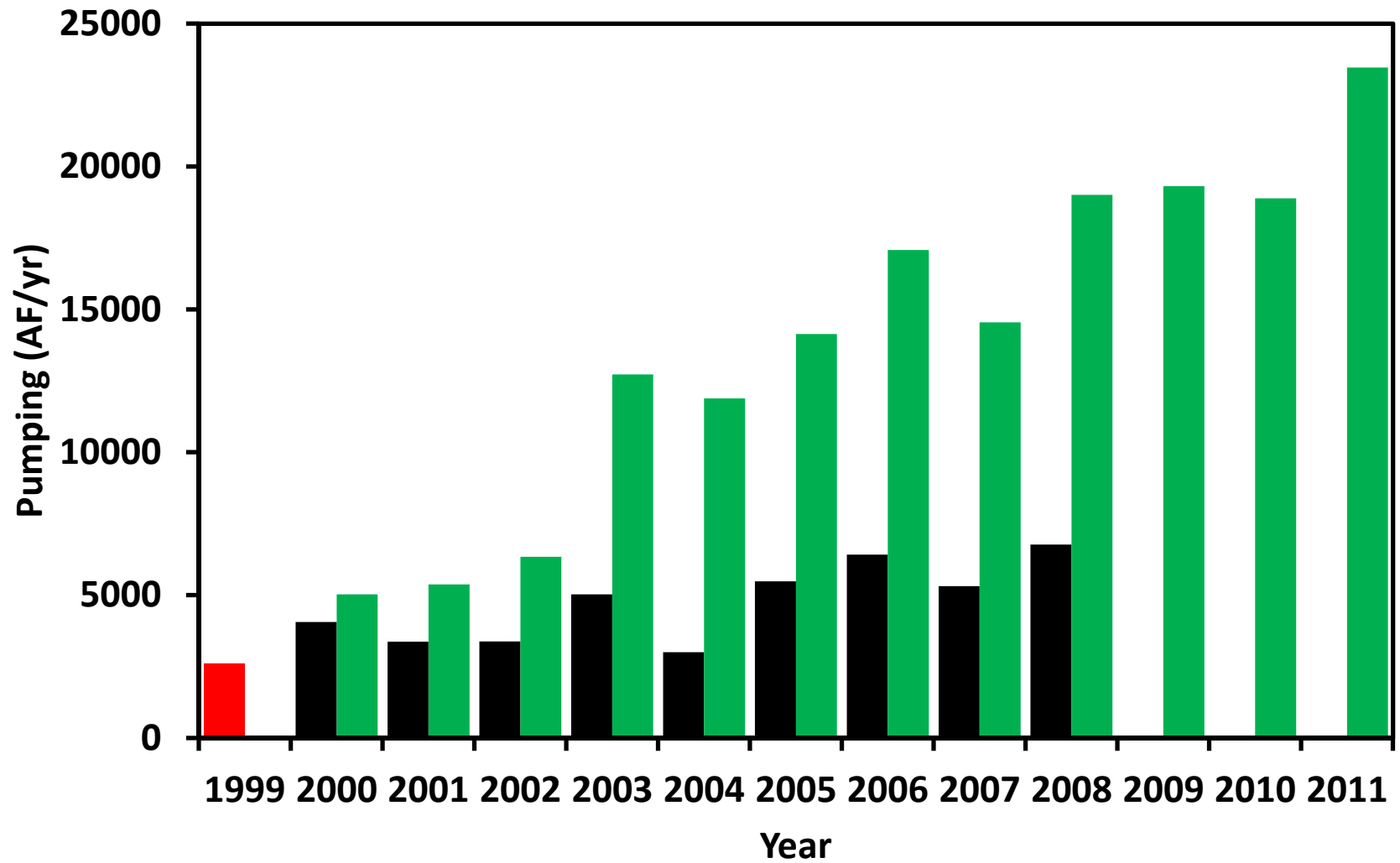

1999 from GAM
2000 to 2008 from TWDB WUS

Guadalupe County Carrizo-Wilcox Aquifer

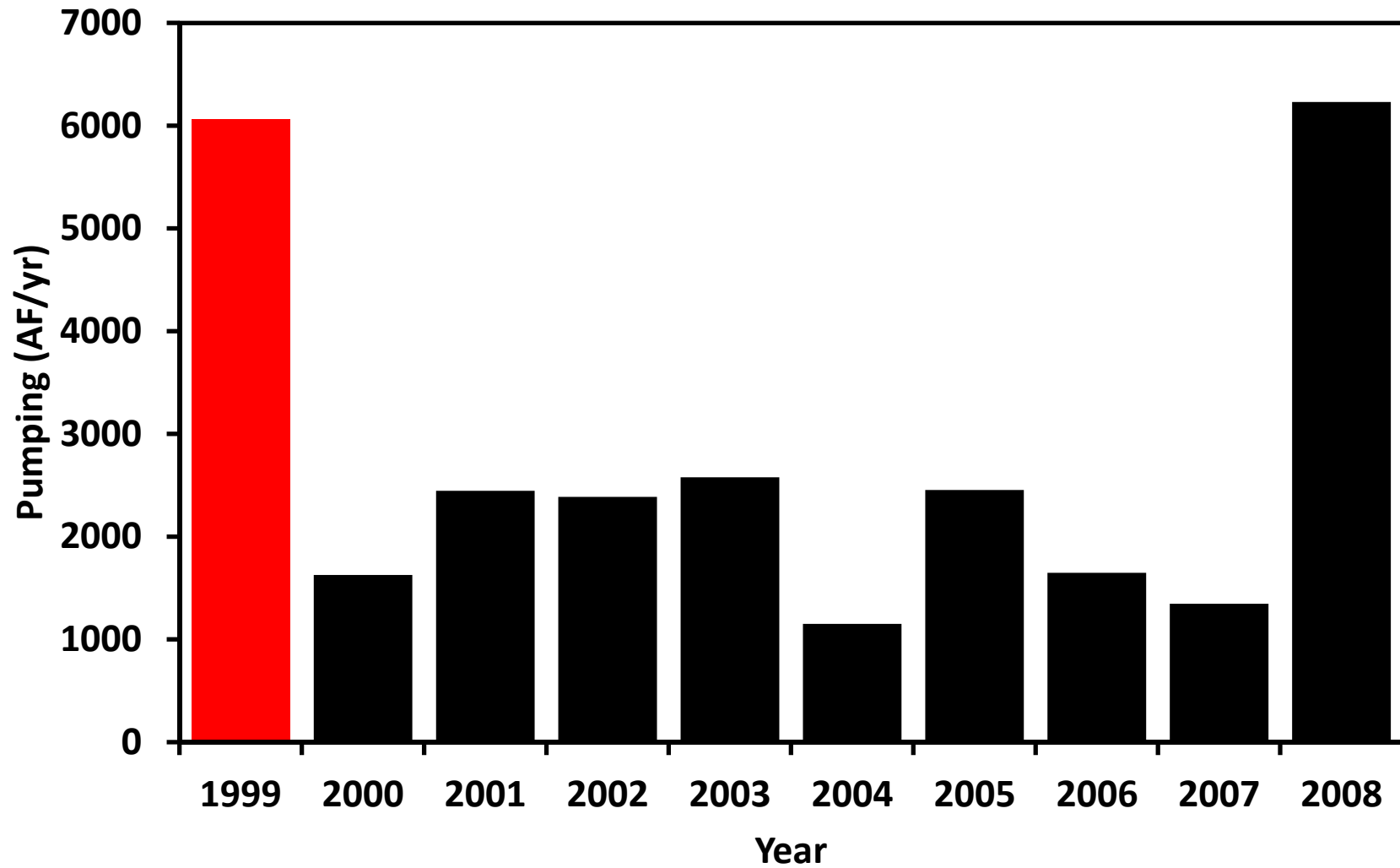

1999 from GAM
2000 to 2008 from TWDB WUS

Karnes County Carrizo-Wilcox Aquifer

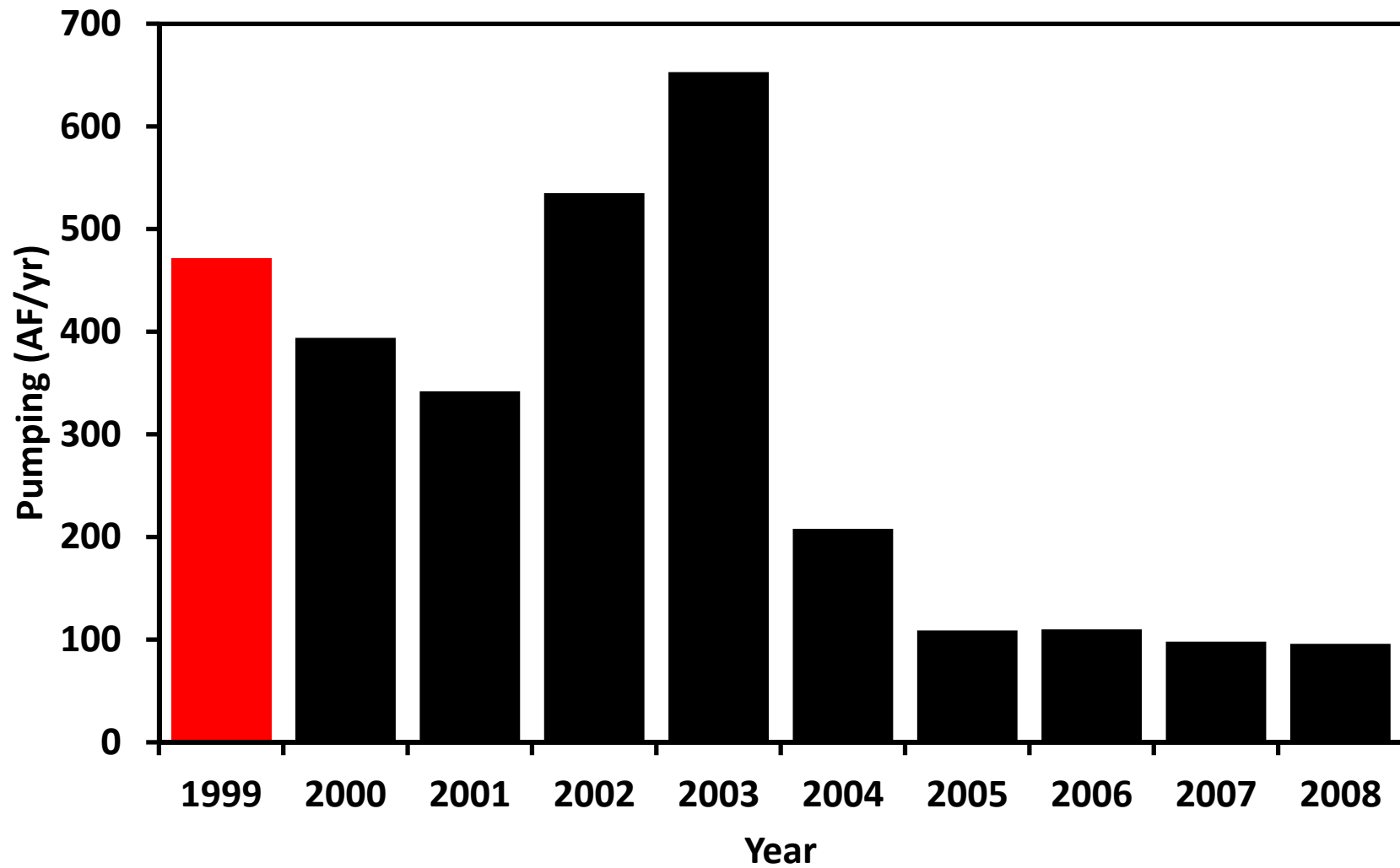

1999 from GAM
2000 to 2008 from TWDB WUS

La Salle County Carrizo-Wilcox Aquifer

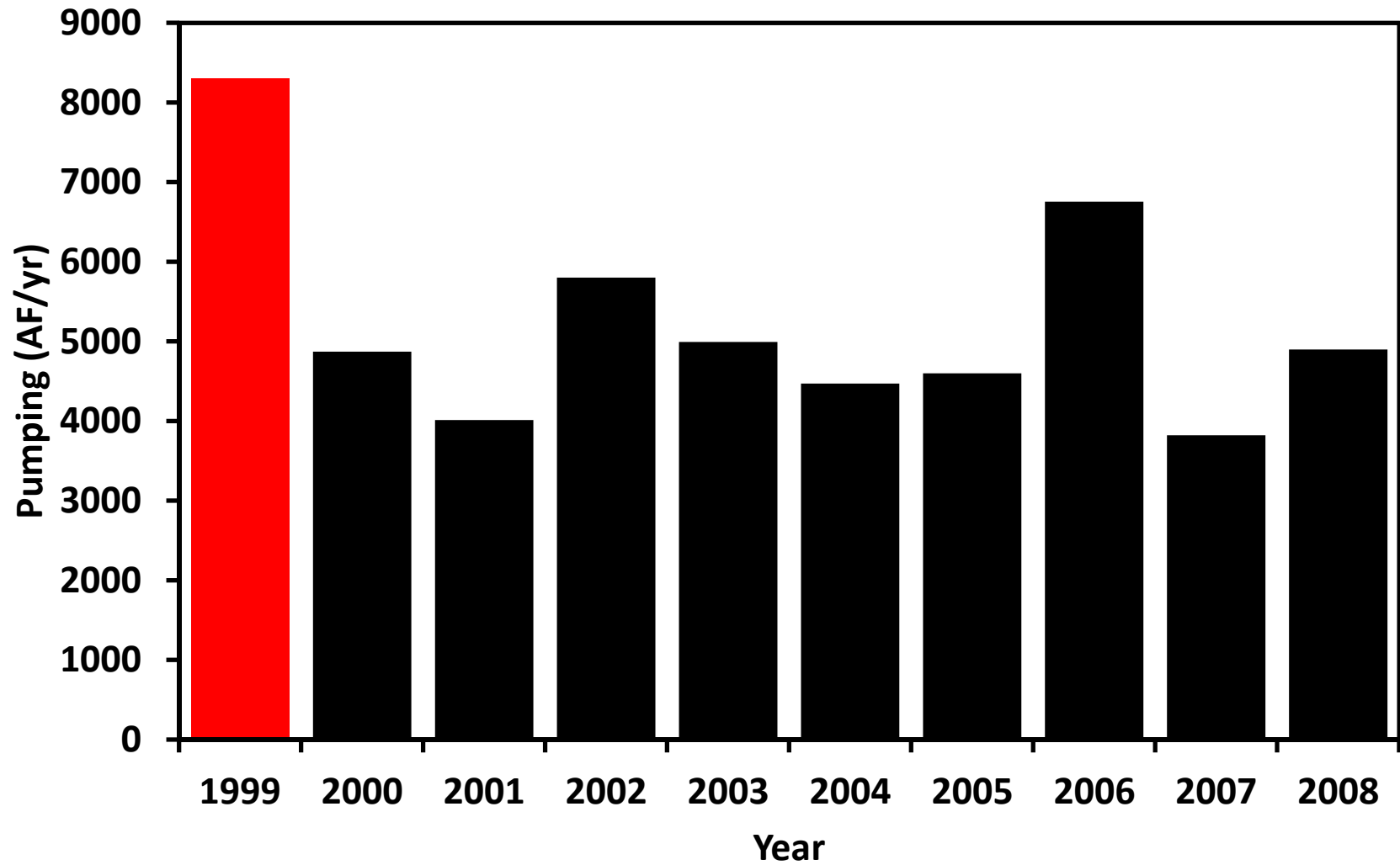

1999 from GAM
2000 to 2008 from TWDB WUS

Maverick County Carrizo-Wilcox Aquifer

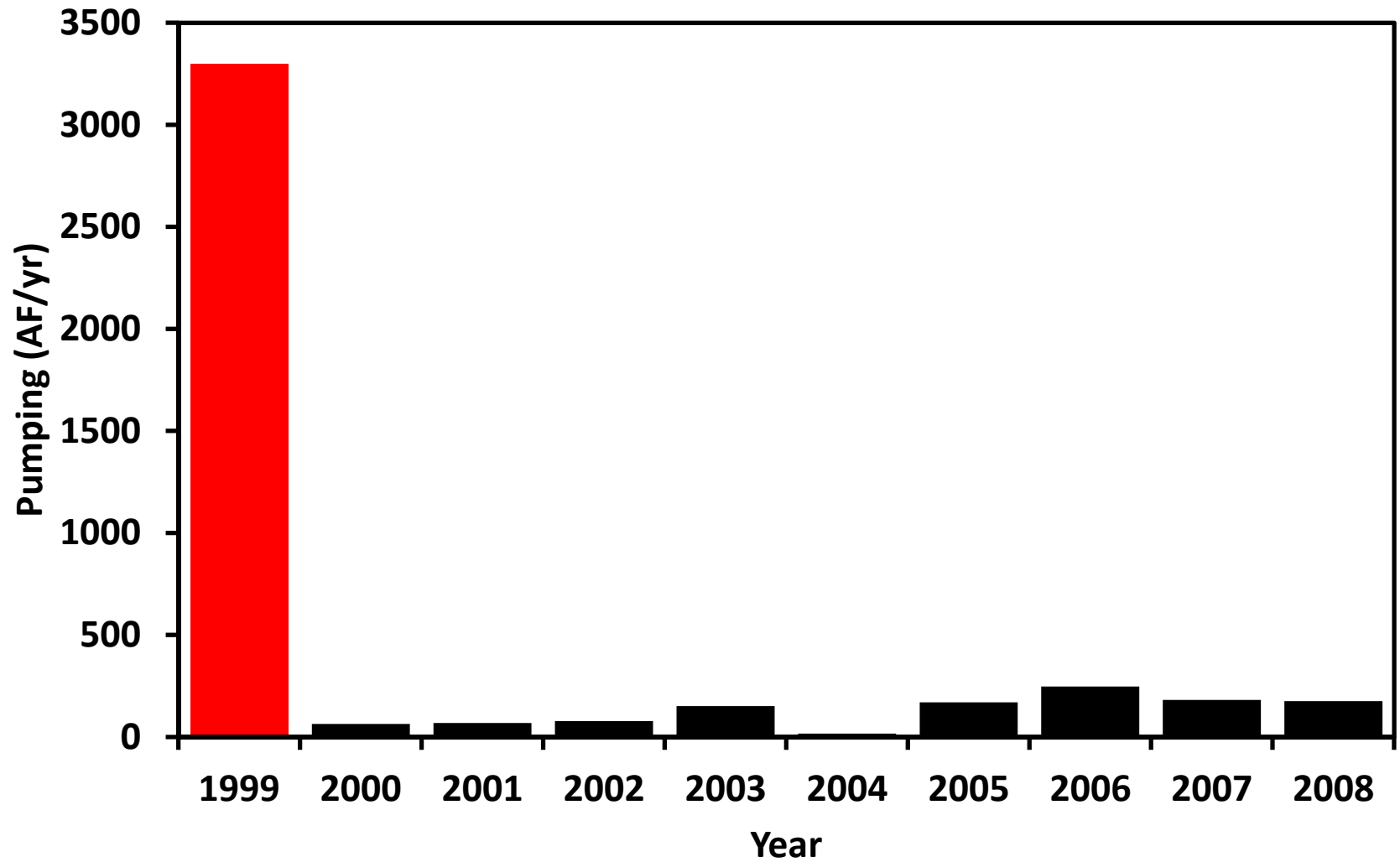

1999 from GAM
2000 to 2008 from TWDB WUS
2000 to 2011 from GCD

McMullen County Carrizo-Wilcox Aquifer

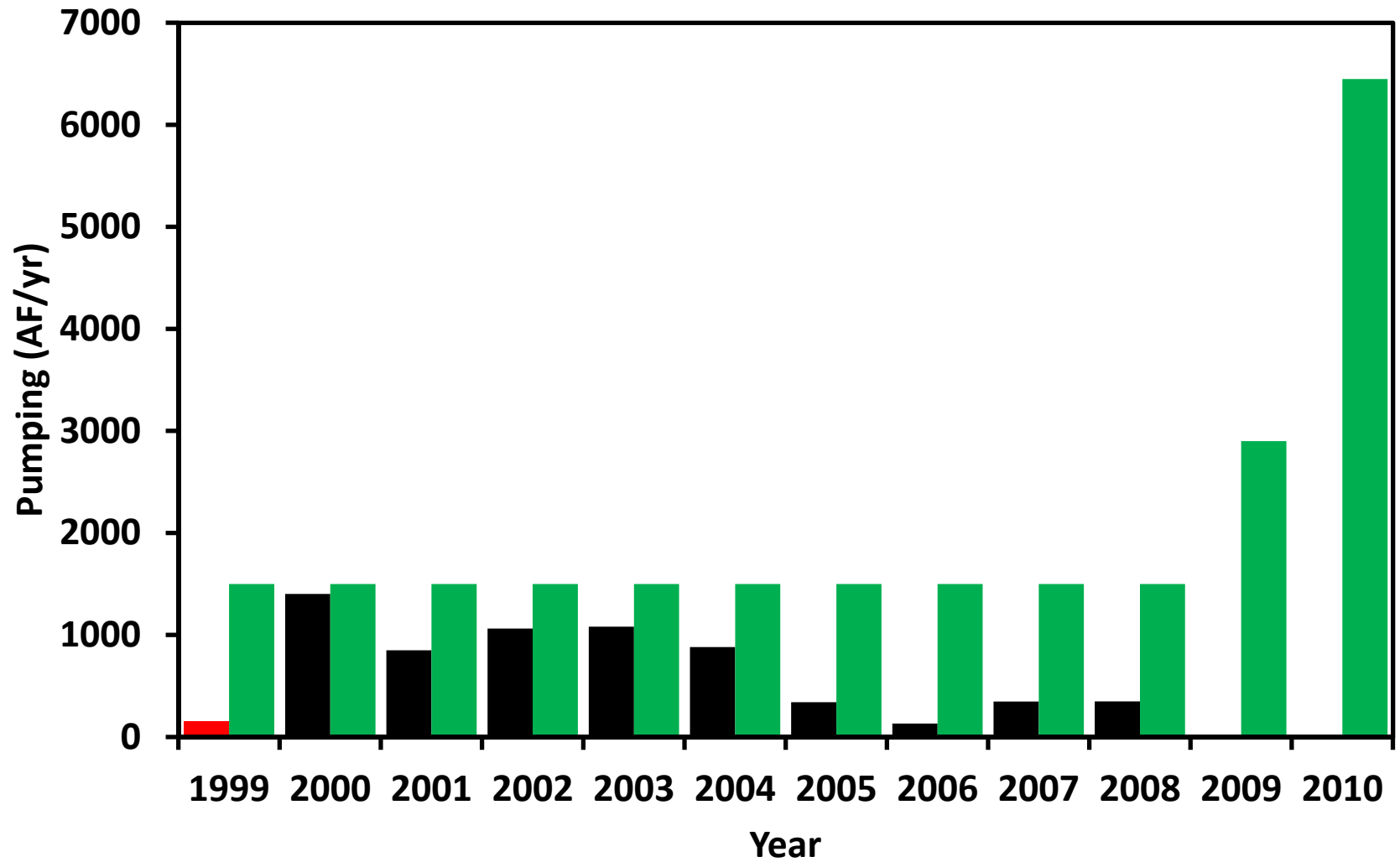

1999 from GAM
2000 to 2008 from TWDB WUS

Medina County Carrizo-Wilcox Aquifer

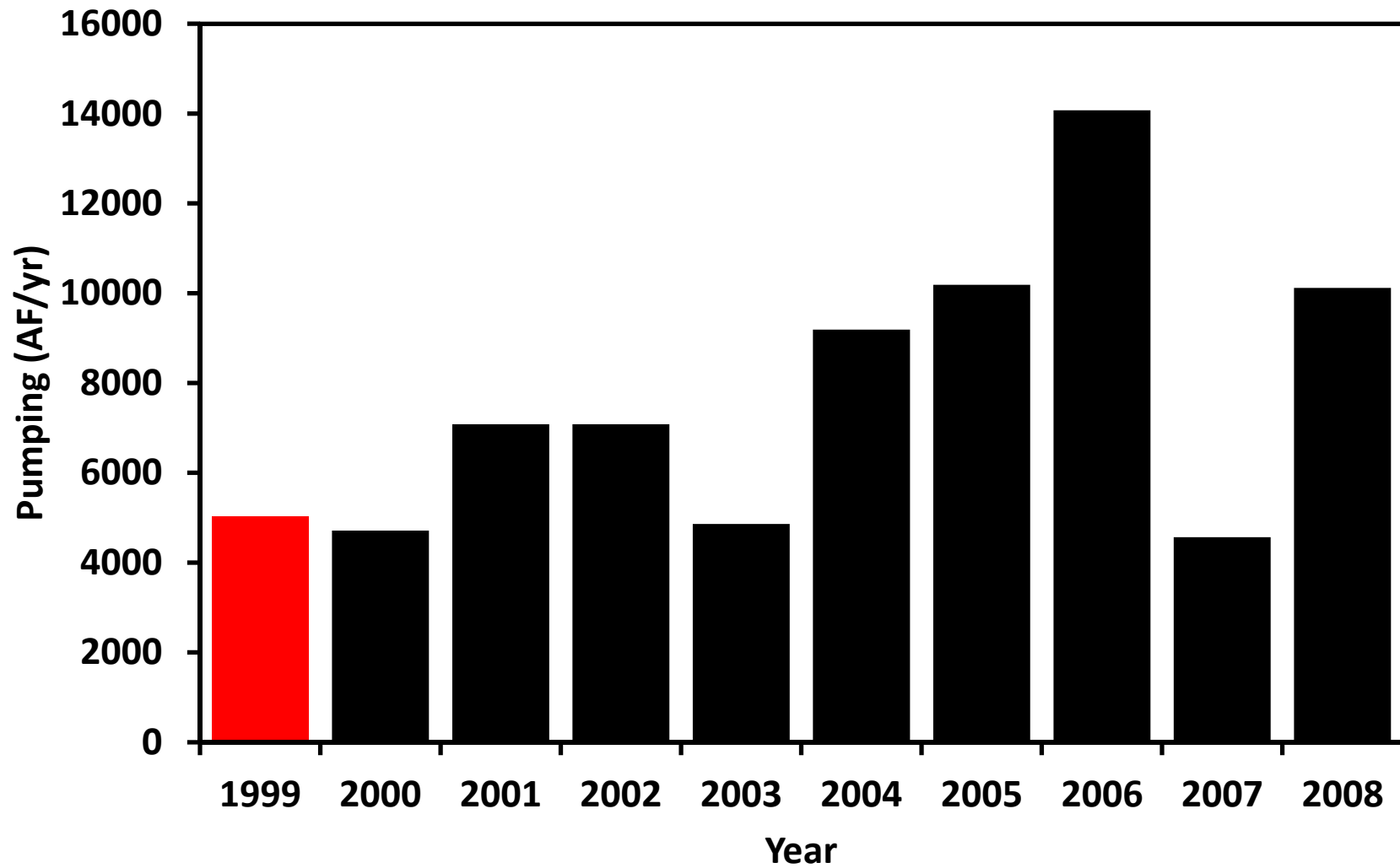

1999 from GAM
2000 to 2008 from TWDB WUS

Uvalde County Carrizo-Wilcox Aquifer

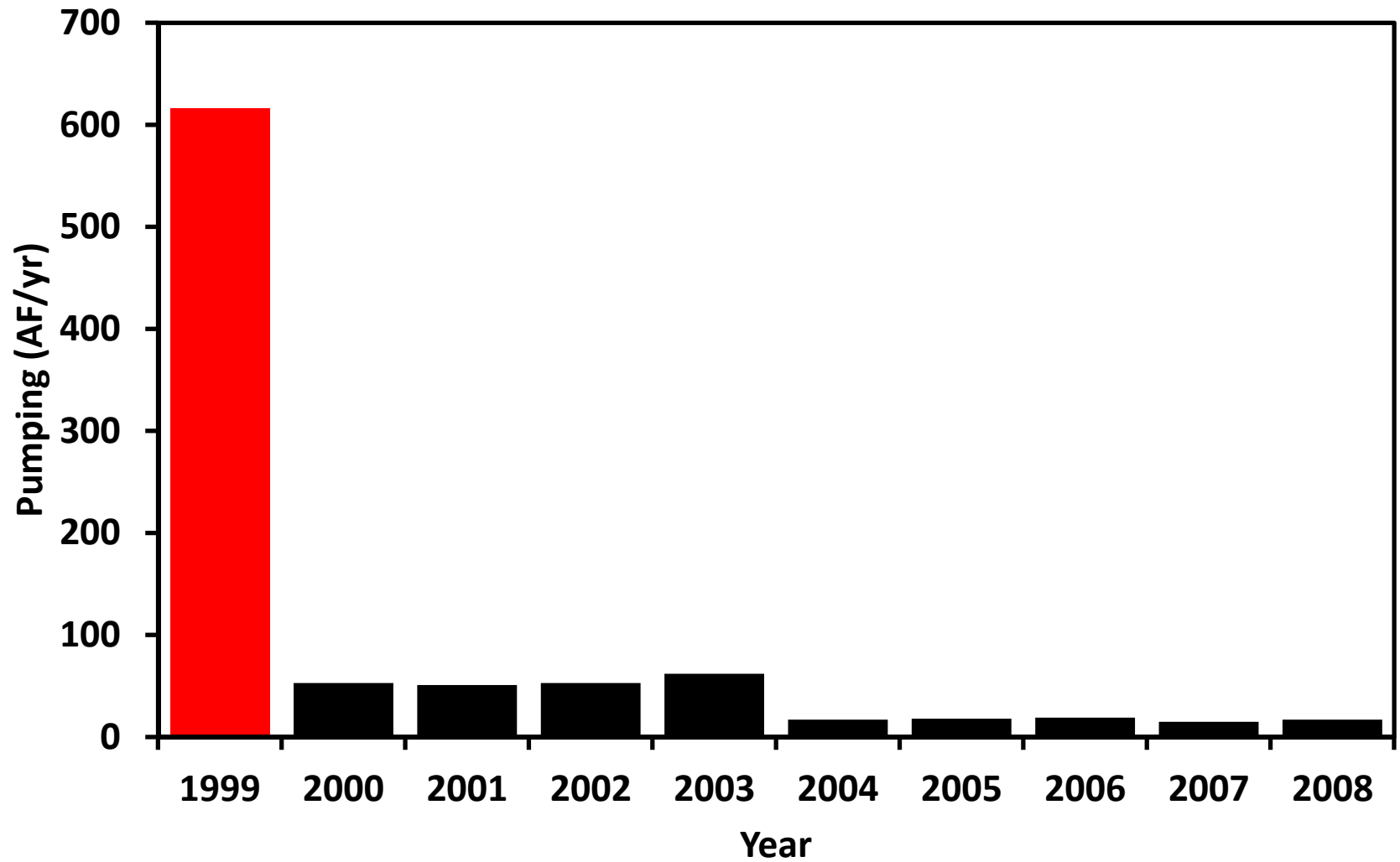

1999 from GAM
2000 to 2008 from TWDB WUS

Webb County Carrizo-Wilcox Aquifer

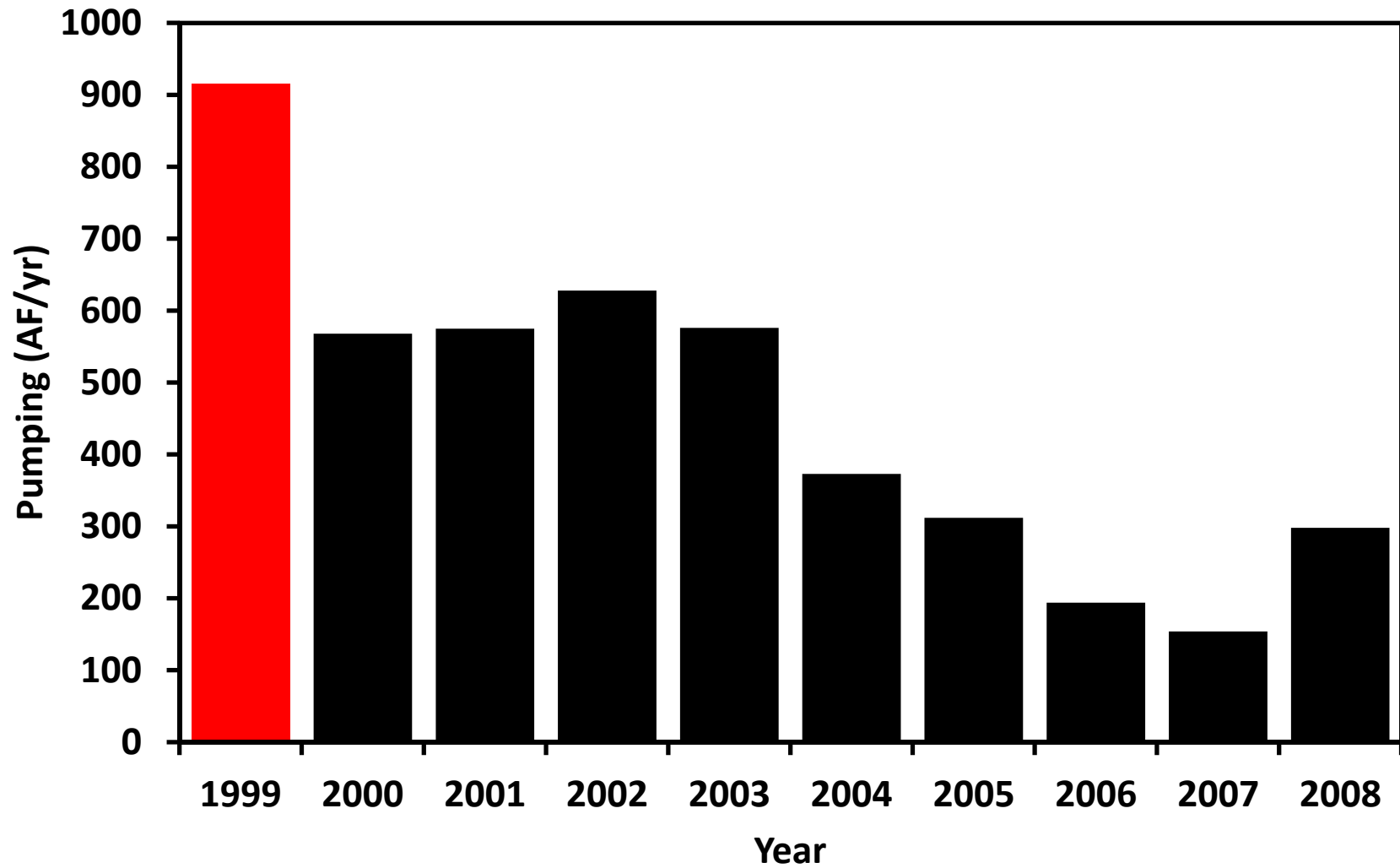

1999 from GAM
2000 to 2008 from TWDB WUS

Wilson County Carrizo-Wilcox Aquifer

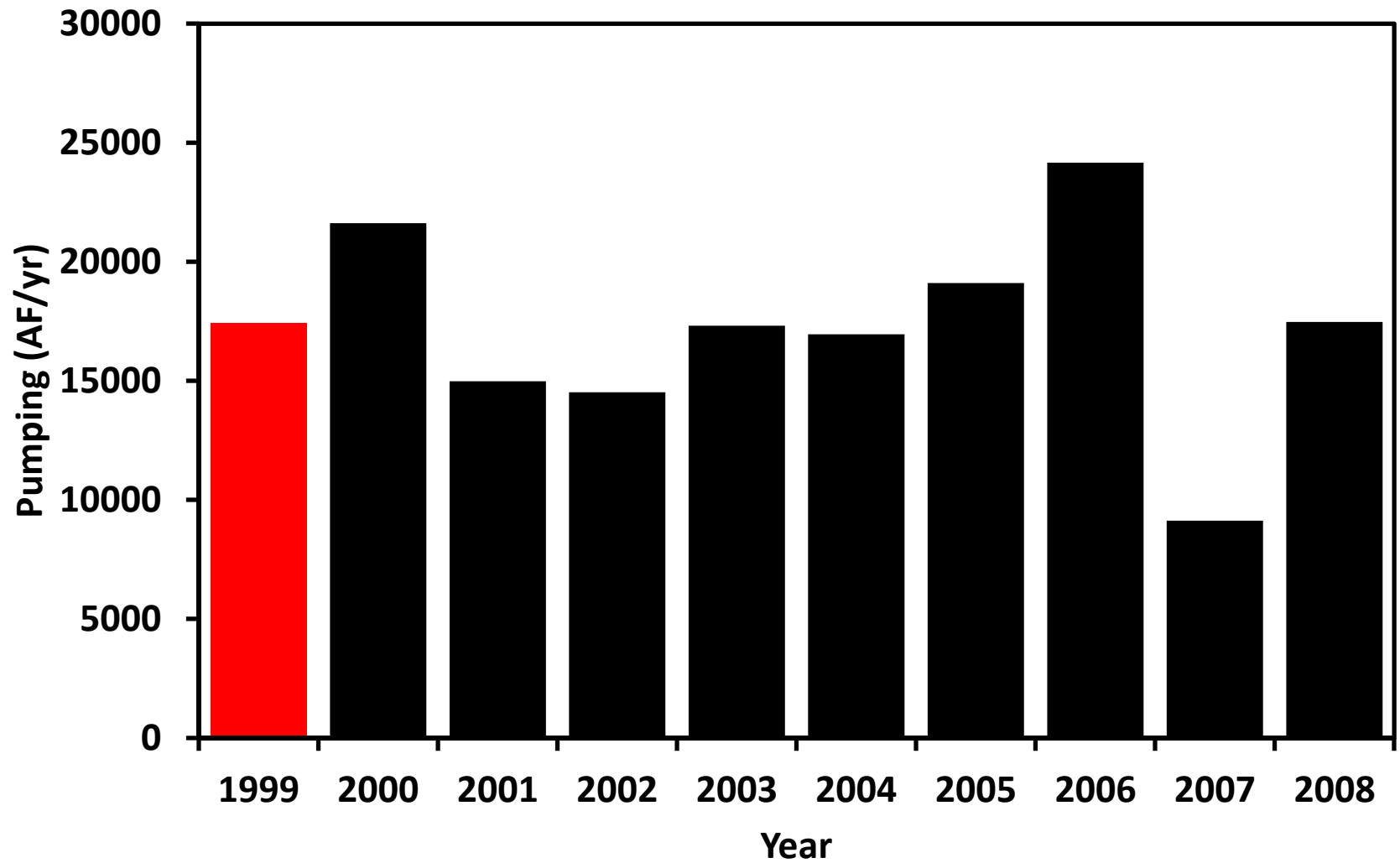

1999 from GAM
2000 to 2008 from TWDB WUS

Zavala County Carrizo-Wilcox Aquifer

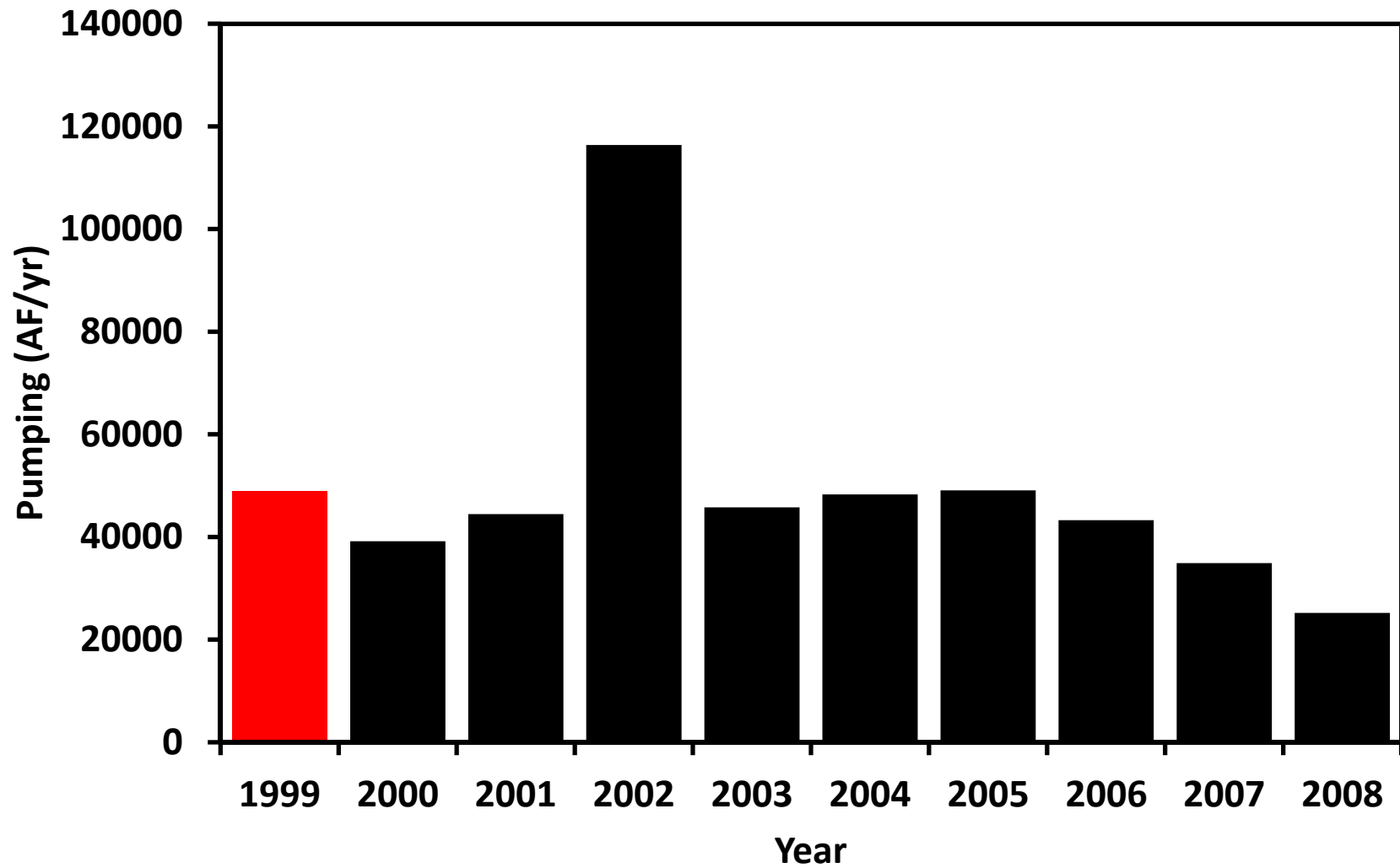

Appendix C

Comparison of Groundwater Monitoring Data with Groundwater Model Results, Groundwater Management Area 13

Final Report

Comparison of Groundwater Monitoring Data with Groundwater Model Results

Groundwater Management Area 13

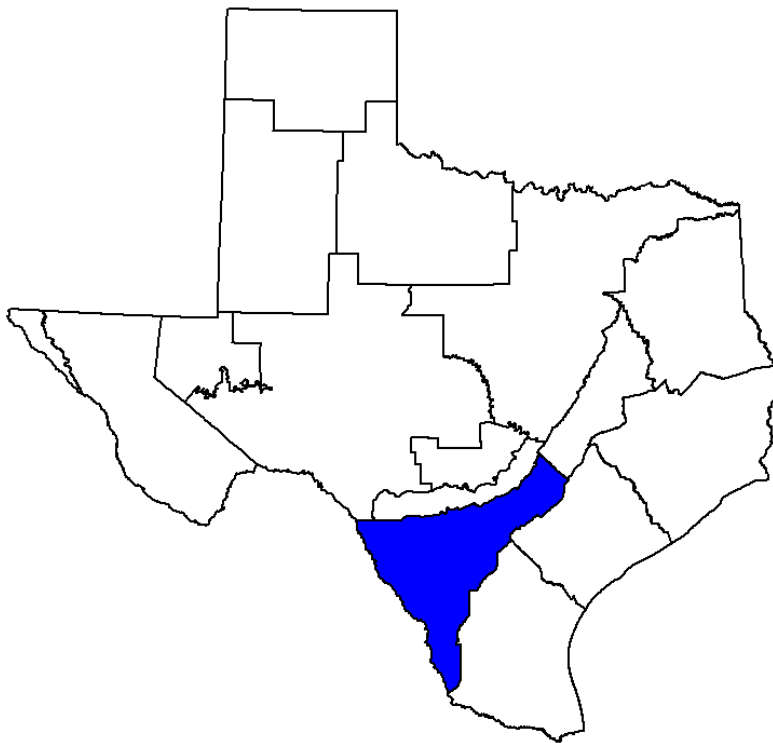

March 20, 2013

William R. Hutchison, Ph.D., P.E., P.G.

Independent Groundwater Consultant

9802 Murmuring Creek Drive

Austin, TX 78736

512-745-0599

billhutch@texasgw.com

Executive Summary

This effort was authorized by the groundwater conservation districts of GMA 13 as the initial step of the current round of joint planning. The objectives were:

1. Compare model results from desired future condition simulations with actual data, and identify areas where comparisons were favorable and unfavorable. In areas where comparisons were unfavorable, the objective was to assess how the accuracy of various assumptions made in the process.
2. Summarize these findings in a report suitable for use by the groundwater conservation districts in updates to their management plans.
3. Use the findings in the next round of joint planning (i.e. desired future condition development) to make the process more efficient, less costly, and more defensible.

This report represents a resource document for use in the current round of joint planning, and contains the results of analyses completed to meet the objectives:

- Plotting hydrographs of actual groundwater elevations for 92 wells and comparing the data to estimates of historic and future pumping and estimates of groundwater elevations at those points from the model simulation of the initial desired future condition statement.
- Comparing actual drawdowns (from 1999 conditions) and drawdowns estimated from the model simulation at those points of the initial desired future condition statement for 70 wells.

In general, the comparisons of actual drawdowns and estimated drawdowns from the desired future condition simulation were favorable. Differences appear to be attributable to pumping increases or decreases assumed to occur from 2000 to 2011 that did not occur, increased groundwater use associated with hydraulic fracturing operations, and drought conditions.

The establishment of the initial desired future conditions for the Carrizo-Wilcox, Queen City and Sparta aquifers relied heavily on simulations using the groundwater availability model of the area. Comparisons of these model results with actual data provide a foundation for future discussions related to the current round of joint planning. The major areas for discussion include:

- Improvement in 2000 to 2011 pumping estimates
- Timing of future pumping increases and decreases
- Evaluate the “average” recharge assumption for the entire DFC simulation
- Evaluate the assumption that future pumping does not vary between wet years and droughts
- Review model assumptions and implementation for recharge and stream flow
- Assess county-to-county impacts more explicitly
- The use of actual well data as part of the statement of desired future conditions

Table of Contents

Executive Summary	1
List of Figures and Tables.....	3
1.0 Introduction.....	4
1.1 Background and Objectives	6
1.2 Initial Desired Future Conditions for GMA 13.....	6
1.3 Comparing Model Results with Monitoring Data.....	7
2.0 Review of GAM Run 09-034.....	8
3.0 Point-by-Point Comparison of Groundwater Elevations	19
3.1 Hydrographs of Groundwater Elevations and Pumping	19
3.2 Well-by-Well Drawdown Comparison	23
3.3 Average Drawdown Comparison.....	28
4.0 County-Level Data Suitable for use in Management Plan Updates	31
5.0 Recommendations for Current Round of Joint Planning.....	32
Appendix 1 – GMA 13 Drawdown Maps for All Years.....	34
Appendix 2 – Atascosa County.....	46
Appendix 3 – Bexar County	57
Appendix 4 – Caldwell County.....	60
Appendix 5 – Dimmit County	69
Appendix 6 – Frio County	79
Appendix 7 – Gonzales County	88
Appendix 8 – Guadalupe County.....	98
Appendix 9 – La Salle County.....	106
Appendix 10 – Maverick County.....	115
Appendix 11 – McMullen County	123
Appendix 12 – Medina County.....	131
Appendix 13 – Webb County	138
Appendix 14 – Wilson County	146
Appendix 15 – Zavala County	160
Appendix 16 – Responses to Comments from Draft Report dated December 21, 2012	170

List of Figures and Tables

Figure 1. Groundwater Management Area 13	4
Figure 2. Counties Entirely or Partially in GMA 13.....	5
Figure 3. Groundwater Conservation Districts in GMA 13.....	5
Figure 4. Summary of Pumping and Drawdown - GMA 13.....	10
Figure 5. Summary of Pumping and Drawdown - Atascosa County.....	10
Figure 6. Summary of Pumping and Drawdown - Bexar County.....	11
Figure 7. Summary of Pumping and Drawdown - Caldwell County.....	11
Figure 8. Summary of Pumping and Drawdown - Dimmit County.....	12
Figure 9. Summary of Pumping and Drawdown - Frio County	12
Figure 10. Summary of Pumping and Drawdown - Gonzales County	13
Figure 11. Summary of Pumping and Drawdown - Guadalupe County.....	13
Figure 12. Summary of Pumping and Drawdown - Karnes County.....	14
Figure 13. Summary of Pumping and Drawdown - La Salle County	14
Figure 14. Summary of Pumping and Drawdown - Maverick County.....	15
Figure 15. Summary of Pumping and Drawdown - McMullen County	15
Figure 16. Summary of Pumping and Drawdown - Medina County.....	16
Figure 17. Summary of Pumping and Drawdown - Uvalde County.....	16
Figure 18. Summary of Pumping and Drawdown - Webb County.....	17
Figure 19. Summary of Pumping and Drawdown - Wilson County.....	17
Figure 20. Summary of Pumping and Drawdown - Zavala County	18
Figure 21. Map of Hydrograph Well Locations.....	20
Figure 22. Locations of Wells Used in Drawdown Comparison.....	24
Figure 23. Summary of Differences between DFC Drawdown and Actual Drawdown for All Years	27
Figure 24. Comparison of Actual Drawdown with DFC Drawdown by Year – GMA 13.....	27
Figure 25. DFC Drawdown minus Actual Drawdown, Average by Year - GMA 13	29
Figure 26. Hydrograph of Average Actual Drawdown and Average DFC Drawdown.....	30
Table 1. Active Model Cell County by County and Model Layer.....	8
Table 2. Summary of Estimated Drawdowns in 2060 by County and Model Layer.....	9
Table 3. Summary Data for 92 Wells used in Hydrograph Construction.....	21
Table 4. Wells Used in Drawdown Comparison	25
Table 5. Summary of GMA 13 Drawdown Comparisons	28

1.0 Introduction

Groundwater Management Area 13 is one of sixteen groundwater management areas in Texas, and covers a large portion of the southwest part of the state (Figure 1).

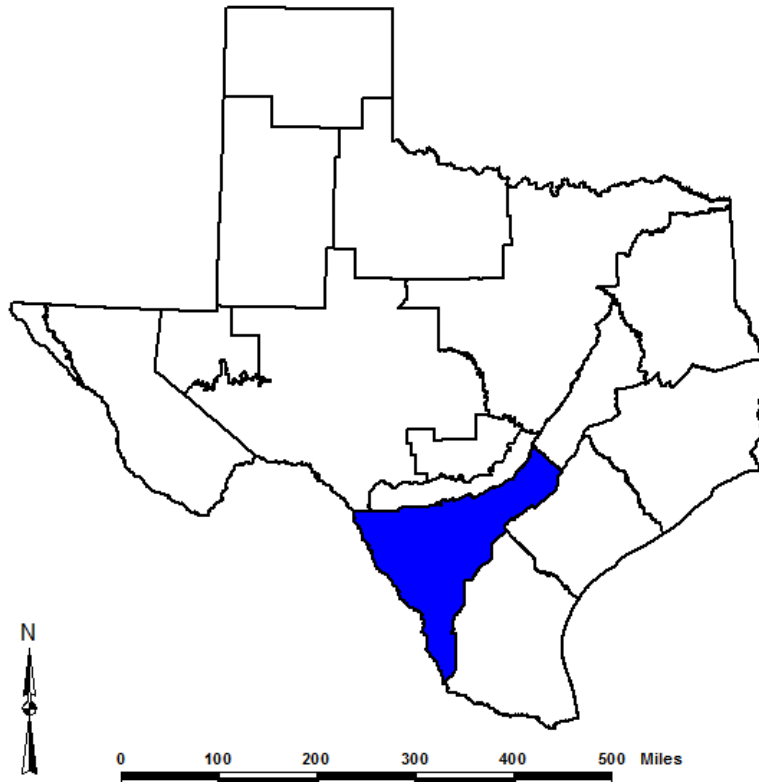

Figure 1. Groundwater Management Area 13

Groundwater Management Area 13 covers all or portions of the following counties: Atascosa, Bexar, Caldwell, Dimmit, Frio, Gonzales, Guadalupe, Karnes, La Salle, Maverick, McMullen, Medina, Uvalde, Webb, Wilson, Zapata, and Zavala (Figure 2).

There are nine groundwater conservation districts in Groundwater Management Area 13: Evergreen Underground Water Conservation District, Gonzales County Underground Water Conservation District, Guadalupe County Groundwater Conservation District, Edwards Aquifer Authority, McMullen Groundwater Conservation District, Medina County Groundwater Conservation District, Plum Creek Conservation District, Uvalde County Underground Water Conservation District, and Wintergarden Groundwater Conservation District (Figure 3). Please note that as shown in Figure 3, the Edwards Aquifer Authority overlaps other groundwater conservation districts in a small portion of Atascosa County, and larger parts of Caldwell, Guadalupe, Medina, and Uvalde counties.

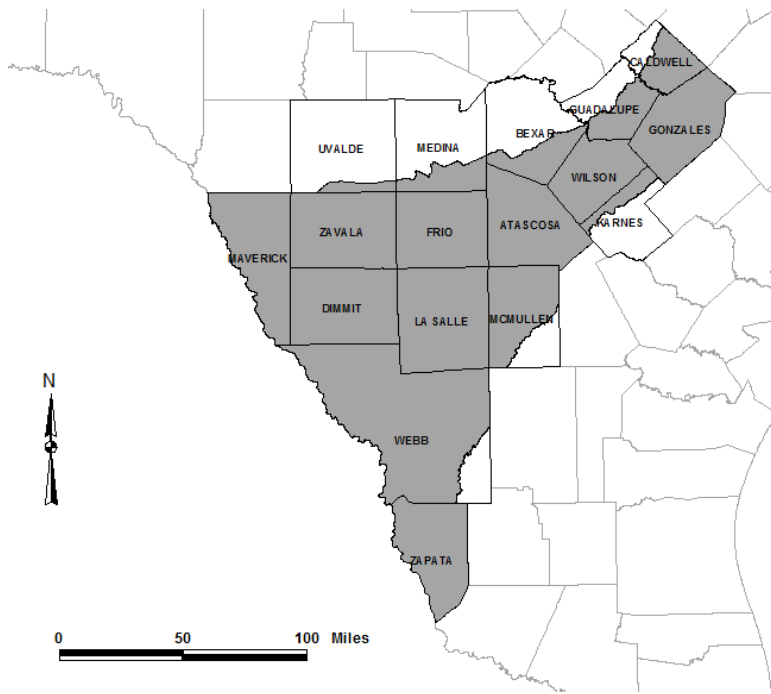

Figure 2. Counties Entirely or Partially in GMA 13

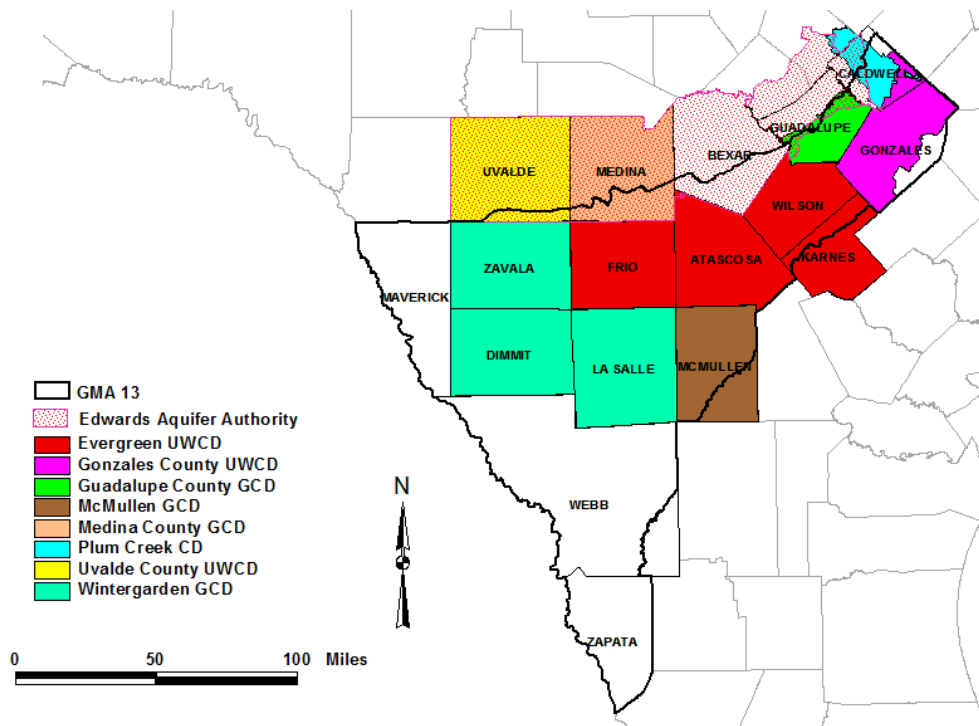

Figure 3. Groundwater Conservation Districts in GMA 13

1.1 Background and Objectives

On May 24, 2012, the groundwater conservation districts in GMA 13 issued a request for qualifications for technical services associated with the development of the next round of desired future conditions. On June 4, 2012, GMA 13 issued a request for proposals that specifically outlined seven tasks that GMA 13 identified relative to assistance in developing and defending desired future conditions. William R. Hutchison, Ph.D., P.E., P.G., an independent groundwater consultant, was selected at the GMA 13 meeting of July 25, 2012 to assist GMA 13 on these tasks. Dr. Hutchison recommended that an additional task be completed prior to beginning any of the tasks listed in the June 4, 2012 request for proposal. Known as Task 0, this task consisted of comparing actual groundwater elevation and drawdown data with model results that were used in the establishment of the initial desired future condition. Authorization to proceed with Task 0 was made at the September 7, 2012 GMA 13 meeting, and was based on two proposals dated August 10, 2012 and August 31, 2012.

The objectives of Task 0 were:

1. Compare model results from desired future condition simulations with actual data, and identify areas where comparisons were favorable and unfavorable. In areas where comparisons were unfavorable, the objective was to assess the accuracy of various assumptions made in the process.
2. Summarize these findings in a report suitable for use by the groundwater conservation districts in updates to their management plans.
3. Use the findings in the next round of joint planning (i.e. desired future condition development) to make the process more efficient, less costly, and more defensible.

It should be noted that there is no formal requirement in statute to report findings from this effort. In contrast, statutes do require that district management plans and desired future condition adoptions be approved as administratively complete by the Texas Water Development Board. However, statute does provide for a petition process if a desired future condition is not being met or if a district is not managing to meet a desired future condition. Such a petition would be filed with the Texas Commission on Environmental Quality. If such a petition were filed, the findings in this report could be used to respond to claims made. Most importantly, this effort represents good practice in evaluating groundwater levels measured in wells, and comparing these data with model results to place model results into appropriate context during the next round of joint planning.

1.2 Initial Desired Future Conditions for GMA 13

Groundwater Management Area 13 (GMA 13) adopted a desired future condition (DFC) for the Carrizo-Wilcox, Queen City, and Sparta aquifers on April 9, 2010. This initial DFC was established with a heavy reliance on results from simulations using the Groundwater Availability Model (GAM) for the Southern Carrizo-Wilcox, Queen City and Sparta aquifers. The adopted DFC is expressed as a GMA-wide average drawdown of 23 feet, and is based on Scenario 4 of GAM Run 09-034 as reported by the Texas Water Development Board. Scenario 4 of GAM Run 09-034 was a 61-year simulation with a starting point in the year 2000. Thus, the 23 feet of drawdown is an average drawdown over the entire GMA in these aquifers, and is estimated to

occur in the year 2060.

It is important to note the assumptions associated with Scenario 4 of GAM Run 09-034. These assumptions include a specific distribution of recharge and that the “average” recharge occurs each year of the 61-year simulation. Also, there is an assumed spatial distribution of pumping, and a specific pattern of pumping increases and decreases assumed as part of GAM Run 09-034. Using 1999 pumping as a baseline (the last year of the calibration period of the model), there are some areas where pumping increases, some areas where pumping is about the same as 1999, and some areas where pumping decreases from 1999 amounts.

1.3 Comparing Model Results with Monitoring Data

The emphasis of using model results and averaging the estimated drawdown from the model results over the entire GMA was a topic of a fair degree of discussion at GMA meetings, and was a significant aspect of objections to the DFC articulated in two petitions filed with the Texas Water Development Board in 2011 challenging the reasonableness of the DFC.

Because the DFC is expressed as a GMA-wide average, questions have been raised on how to compare the actual data with idealized and heavily averaged model results to evaluate consistency with the DFC. Monitoring data can be used to track the groundwater level changes and can be compared to the DFC, either on a well-by-well basis, a county basis, a district basis, or on a GMA level.

It is possible to use synoptic groundwater level data (i.e. groundwater level data over many wells collected at the same time) to create contour maps of groundwater levels or drawdown, and then compare the resulting synoptic data with a similar map of model results. However, it is possible that the resulting contours would not be representative of aquifer conditions in the non-monitored areas and the “averaging” associated with the contouring process may lead to erroneous conclusions.

Conversely, it is possible to extract predicted groundwater levels from the model files (which are stored in the model files based on the one-square mile grid cells and for each year of the simulation) at the same locations as the wells that are used in a monitoring program. If the model is well calibrated at these points, this approach would provide some advantage in that comparisons of model results and monitoring data would be consistent, and averaging would be limited, if not eliminated. Conclusions could then be drawn based on the comparison of actual data with model results at discrete locations.

Results of the comparison will provide the districts the ability to evaluate various assumptions that are embedded in the desired future condition. Among these are assumed pumping locations in areas where pumping is expected to increase, the timing and amount of pumping increases and decreases, the adequacy of the selected groundwater availability model to predict drawdown, and the appropriateness of assuming that recharge is average each year for the next 61 years.

2.0 Review of GAM Run 09-034

Scenario 4 of GAM Run 09-034 was used as the basis for establishing the desired future condition in GMA 13. It relied on the groundwater availability model of the Southern Carrizo-Wilcox, Queen City, and Sparta aquifers. This model discretized the flow system into 112 row and 217 columns of one-square mile cells. The groundwater flow system is further discretized into 8 layers of cells to represent various aquifers and aquitards of varying thickness. Thus, there are 194,432 cells in the model, 100,883 of which are active in the flow system. GMA 13 is represented by 82,029 of these active cells, or 81% of all active cells in the model grid. Table 1 summarizes the active cells in each county and layer in the GMA 13 portion of the model.

Table 1. Active Model Cell County by County and Model Layer

County	Layer 1	Layer 2	Layer 3	Layer 4	Layer 5	Layer 6	Layer 7	Layer 8	GMA 13
Atascosa	820	853	1,033	1,073	1,189	1,189	1,216	1,216	8,589
Bexar	0	0	0	8	67	73	193	345	686
Caldwell	0	0	20	61	101	102	241	360	885
Dimmit	145	210	988	1,049	1,203	1,232	1,293	1,311	7,431
Frio	389	460	1,031	1,102	1,129	1,129	1,129	1,129	7,498
Gonzales	787	833	977	1,051	1,065	1,065	1,071	1,071	7,920
Guadalupe	0	0	1	28	102	102	273	383	889
Karnes	186	186	186	186	186	186	186	186	1,488
LaSalle	1,503	1,503	1,503	1,503	1,503	1,503	1,503	1,503	12,024
Maverick	0	0	0	8	64	69	115	206	462
McMullen	853	853	853	853	853	853	853	853	6,824
Medina	0	0	0	2	138	138	259	329	866
Uvalde	0	0	0	0	27	1	90	108	226
Webb	1,087	1,158	1,885	1,933	1,948	1,955	1,962	1,963	13,891
Wilson	316	370	595	662	772	772	805	807	5,099
Zavala	169	230	918	1,026	1,178	1,185	1,257	1,288	7,251
GMA13	6,255	6,656	9,990	10,545	11,525	11,554	12,446	13,058	82,029

The desired future condition was expressed as an average drawdown over the entire area of GMA 13, and was based on the results of Scenario 4 of GAM Run 09-034. Groundwater elevations are calculated for each active cell at the end of each stress period (one year). The drawdown in each cell was calculated as the groundwater elevation at the beginning of the simulation (end of 1999) minus the groundwater elevation at the end of the year of interest. These drawdowns are then summed for an area of interest (e.g. county, layer, county-layer, entire GMA). The average drawdown for an area of interest is then calculated as the sum of the drawdowns divided by the number of cells in the area of interest. Thus, the desired future condition of 23 feet in GMA 13 in 2060 is the average of 82,029 individual drawdown estimates. Also note that this calculation can be completed for any geographic area of interest for any of the 61 stress periods in the simulation (2000 to 2060). There are over 5 million individual drawdown estimates contained in the model files of Scenario 4 of GAM Run 09-034 to make these calculations.

The drawdown estimates by county and layer for 2060 from Scenario 4 of GAM Run 09-034 are summarized in Table 2. Note that blanks in Table 2 correspond to areas where specific layers do not exist (e.g. Layers 1, 2 and 3 do not exist as active cells in Bexar County). By tying a particular model run to the desired future condition, it is possible to extract specific drawdown values for specific areas, down to a one square mile area (a model cell) for any year.

Table 2. Summary of Estimated Drawdowns in 2060 by County and Model Layer

County	Layer 1	Layer 2	Layer 3	Layer 4	Layer 5	Layer 6	Layer 7	Layer 8	GMA 13
Atascosa	10	13	15	43	74	74	85	145	62
Bexar				8	64	48	37	136	90
Caldwell			5	16	96	92	51	65	63
Dimmit	-2	3	-4	-14	-17	-17	-22	-18	-15
Frio	4	3	-3	19	39	38	31	35	24
Gonzales	21	26	32	60	94	94	88	81	65
Guadalupe			-13	5	52	50	20	31	31
Karnes	17	27	34	60	86	85	61	88	57
LaSalle	7	8	9	11	12	12	-1	-9	6
Maverick				1	-8	-12	-11	-3	-7
McMullen	25	29	32	39	45	44	12	9	29
Medina				-1	29	29	28	28	28
Uvalde					1	3	12	30	19
Webb	-7	-4	-9	-5	-4	-3	-1	-3	-4
Wilson	7	13	13	43	75	75	78	153	68
Zavala	-7	-5	-13	-14	2	0	-5	-3	-5
GMA13	9	11	7	17	31	31	25	38	23

It is also possible to extract pumping data from each model cell, both from the calibrated groundwater model (to evaluate estimates of historic pumping) and from Scenario 4 of GAM Run 09-034 (to evaluate assumptions of future pumping). Increases in pumping would be expected to result in higher drawdown, and decreases in pumping would be expected to result in groundwater level stabilization or recovery. This relationship for all of GMA 13 is summarized in Figure 4.

The upper part of Figure 4 contains estimates of historic pumping (1975 to 1999) which were extracted from the calibrated groundwater availability model, and estimates of assumed future pumping (2000 to 2060) which were extracted from Scenario 4 of GAM Run 09-034. Note that “future” pumping included the period 2000 to 2010 (when the DFC was adopted). It can be seen that historic pumping is about 300,000 AF/yr and pumping is assumed to increase to about 420,000 AF/yr in the future. The lower part of Figure 4 shows the annual estimate of average drawdown over all of GMA 13. Note that drawdown estimates begin in the year 2000 and extend to 2060, and the 23 ft of average drawdown in 2060 can be seen. Because the “future” pumping began in 2000 and extends to 2060, it is possible to compare drawdown estimates from 2000 to 2011 with actual monitoring data to advance the objectives of this investigation.

Figures 5 to 20 are similar plots of individual counties. Plots of individual county-layer combinations are not presented, but were developed for later use in the joint planning process, and are available on request.

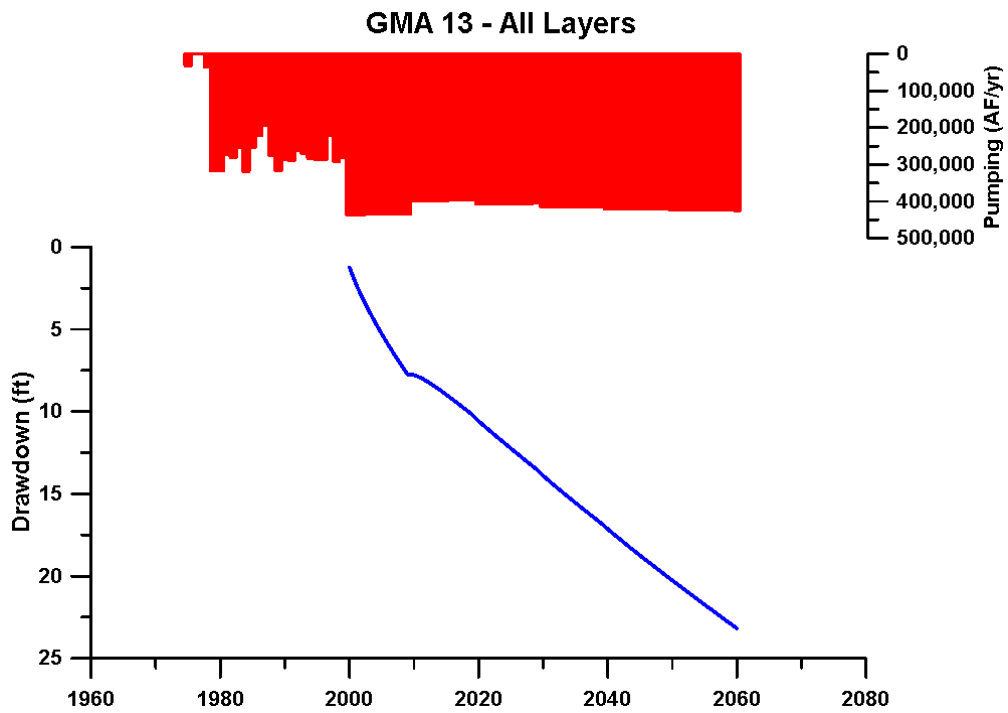

Figure 4. Summary of Pumping and Drawdown - GMA 13

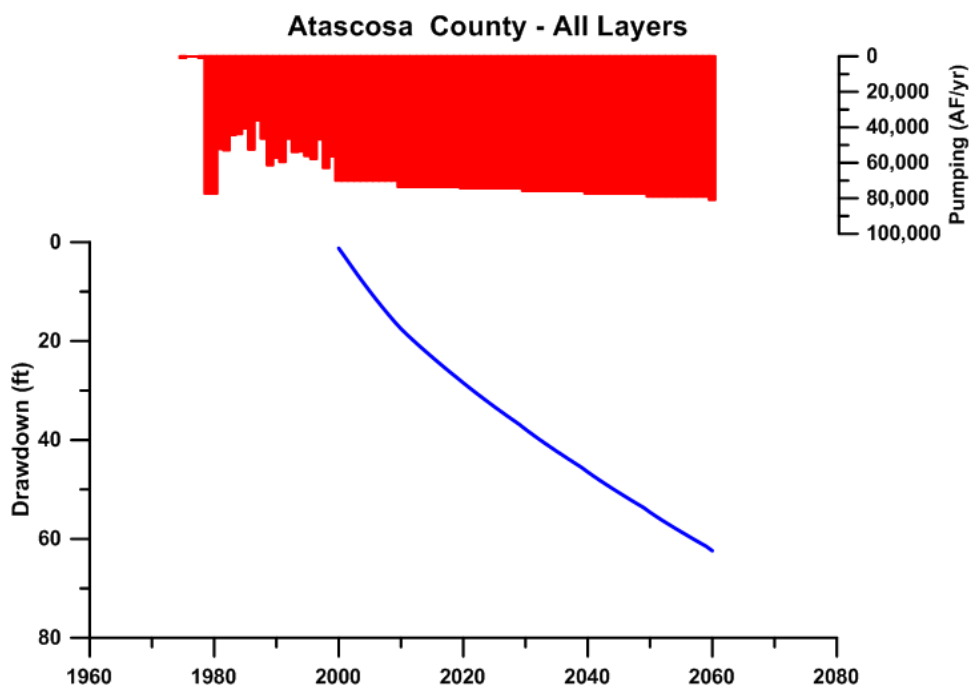

Figure 5. Summary of Pumping and Drawdown - Atascosa County

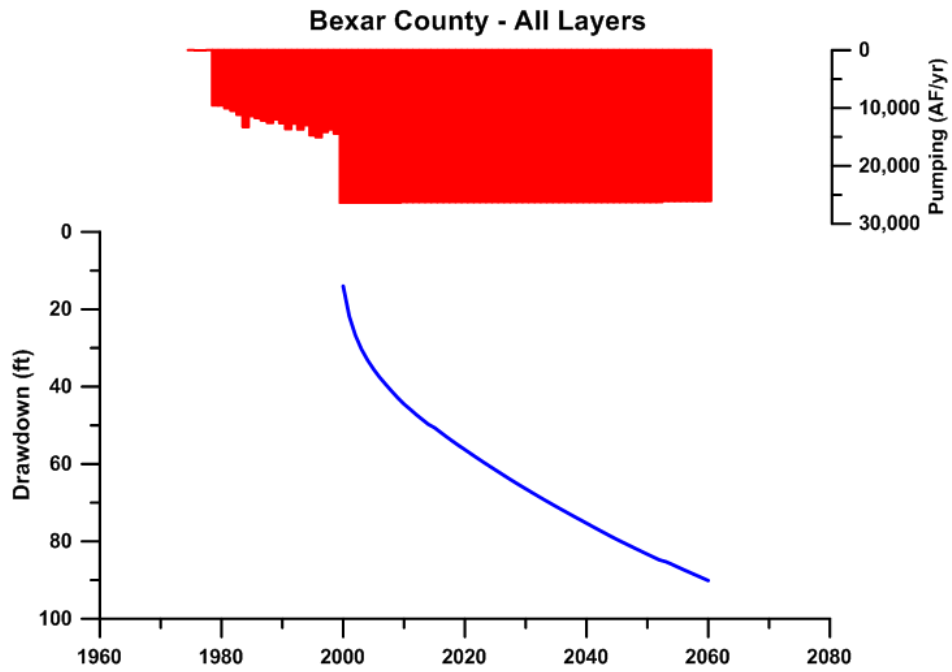

Figure 6. Summary of Pumping and Drawdown - Bexar County

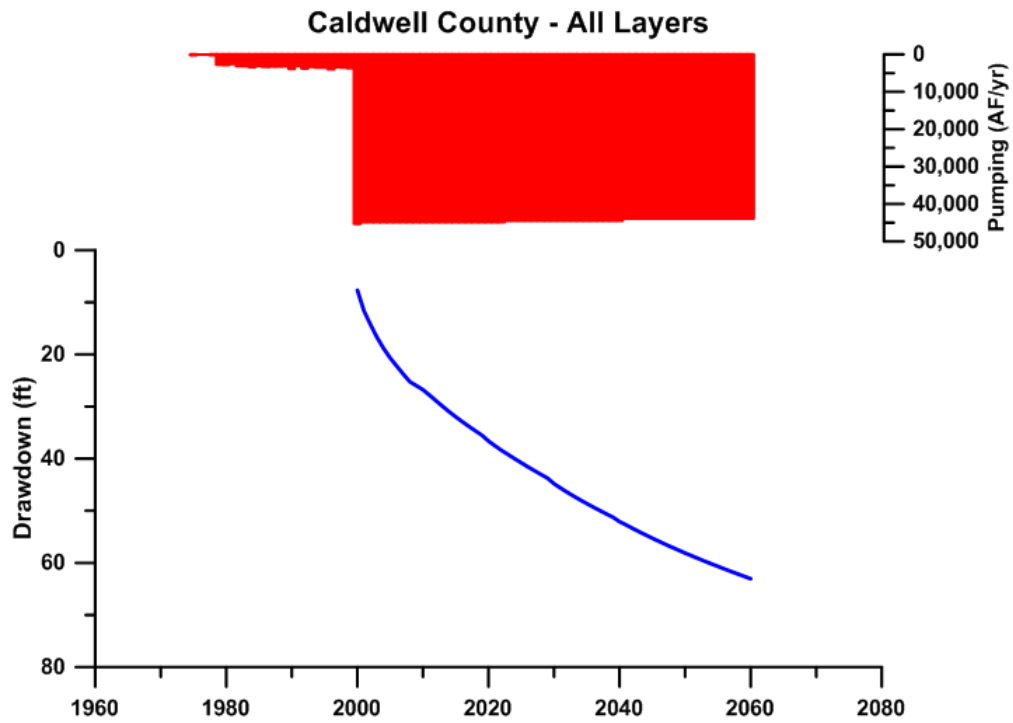

Figure 7. Summary of Pumping and Drawdown - Caldwell County

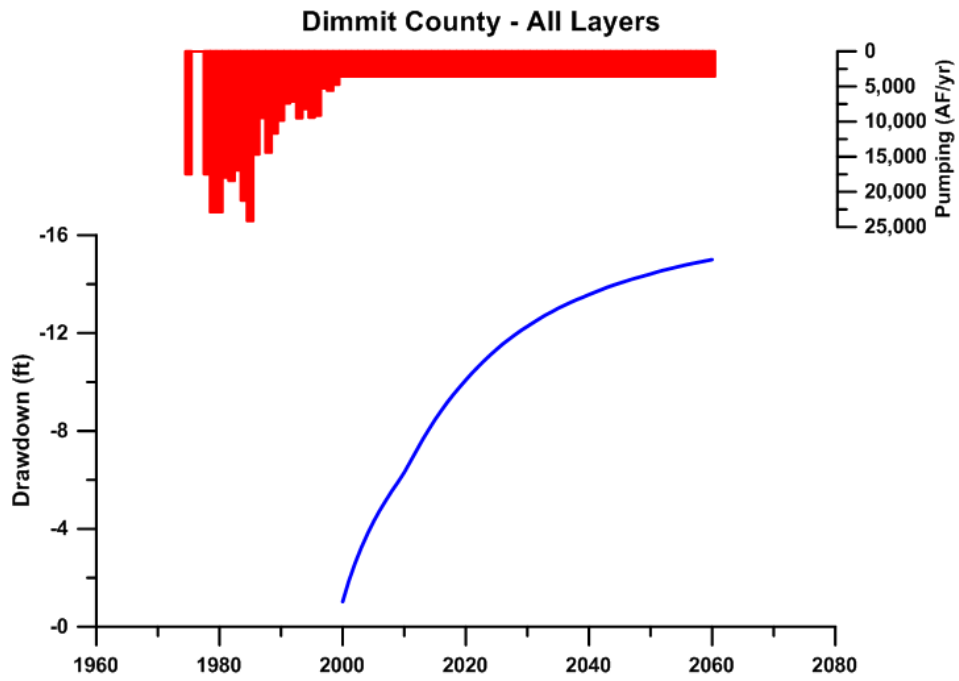

Figure 8. Summary of Pumping and Drawdown - Dimmit County

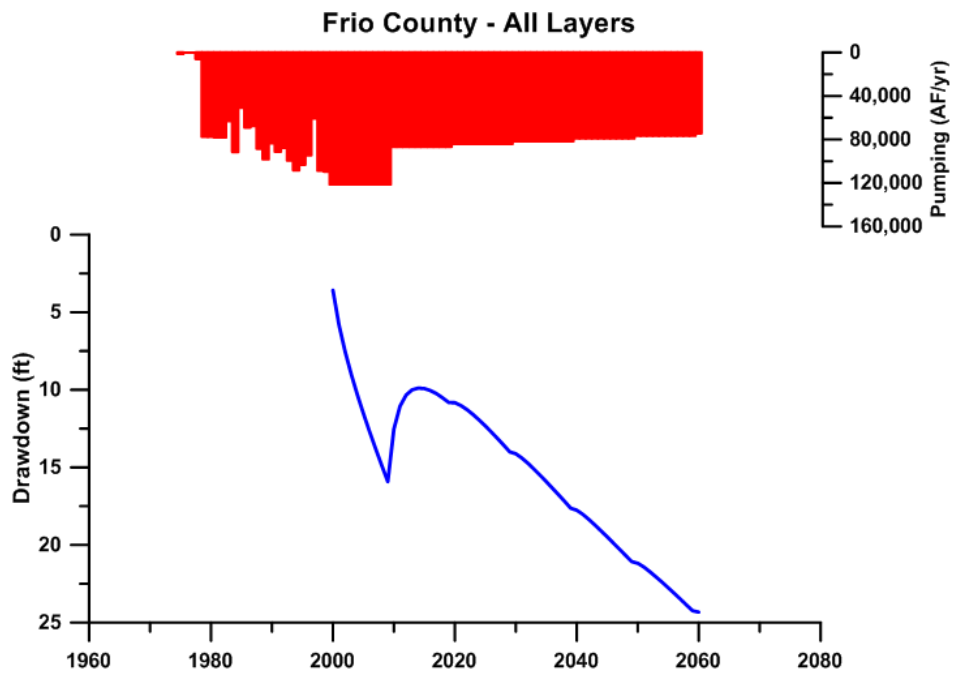

Figure 9. Summary of Pumping and Drawdown - Frio County

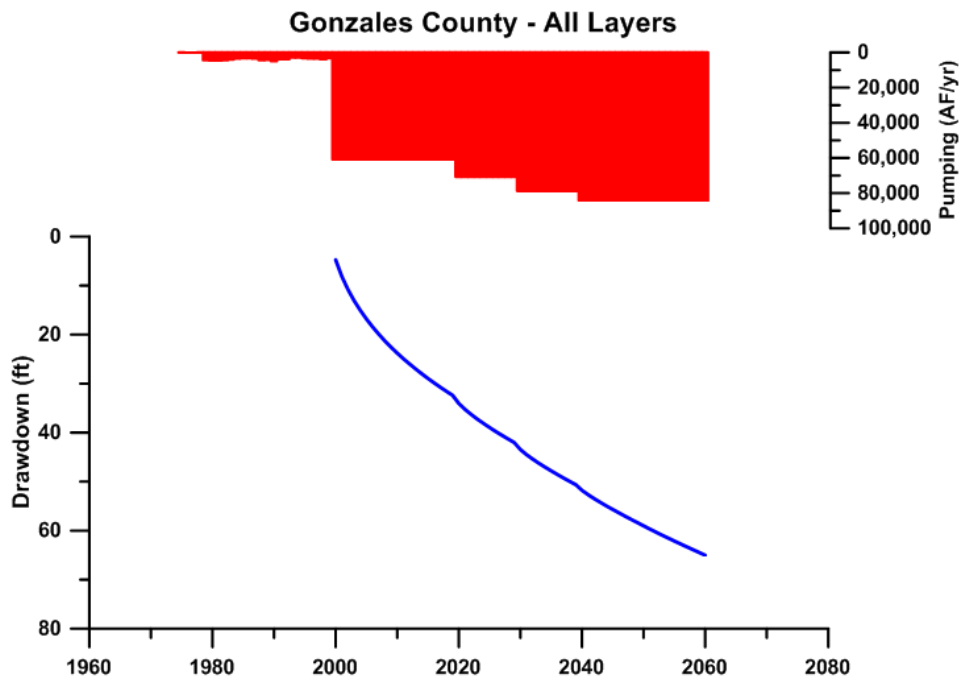

Figure 10. Summary of Pumping and Drawdown - Gonzales County

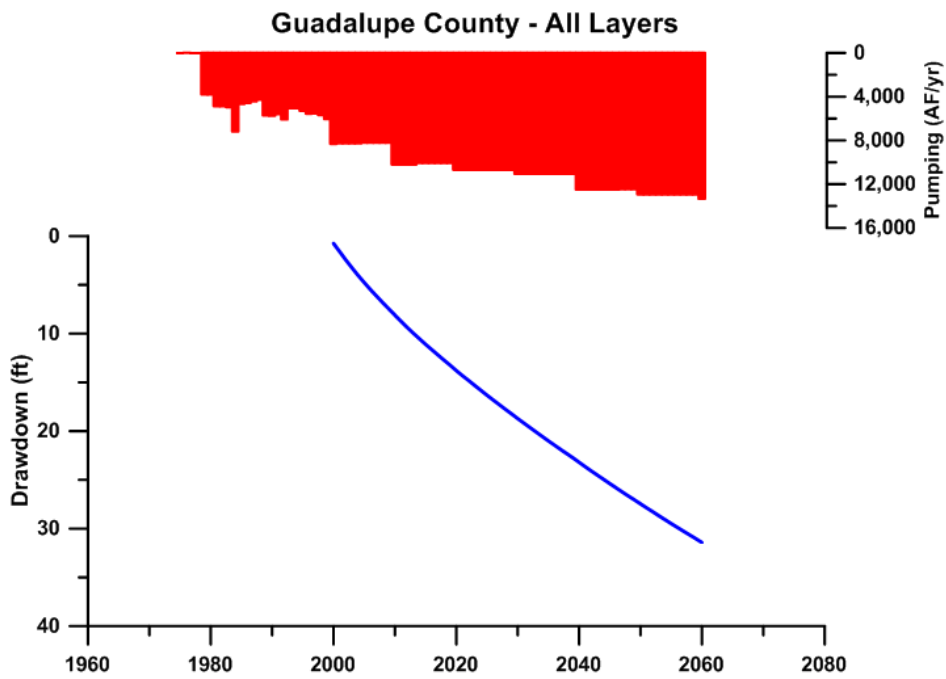

Figure 11. Summary of Pumping and Drawdown - Guadalupe County

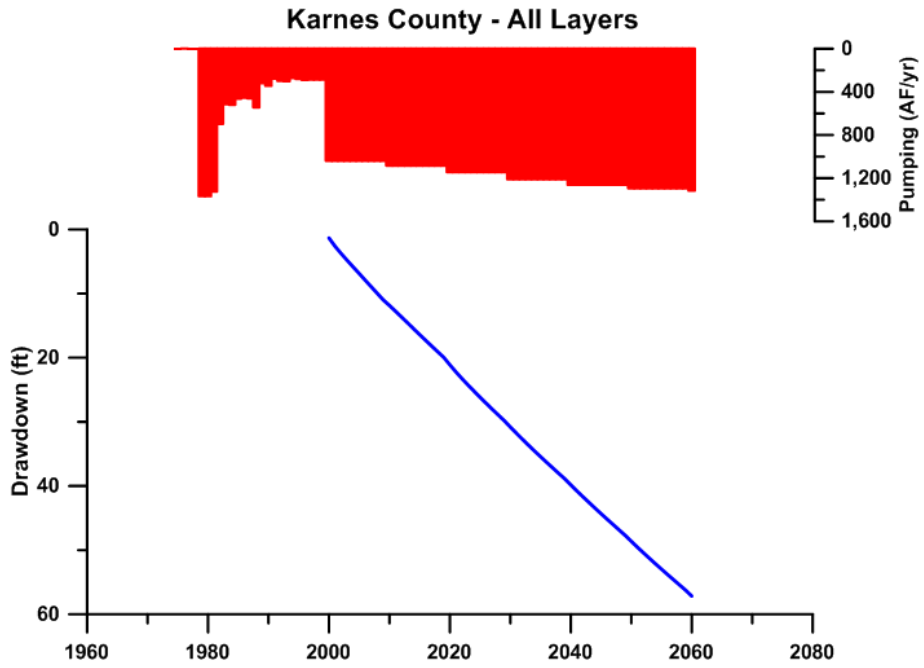

Figure 12. Summary of Pumping and Drawdown - Karnes County

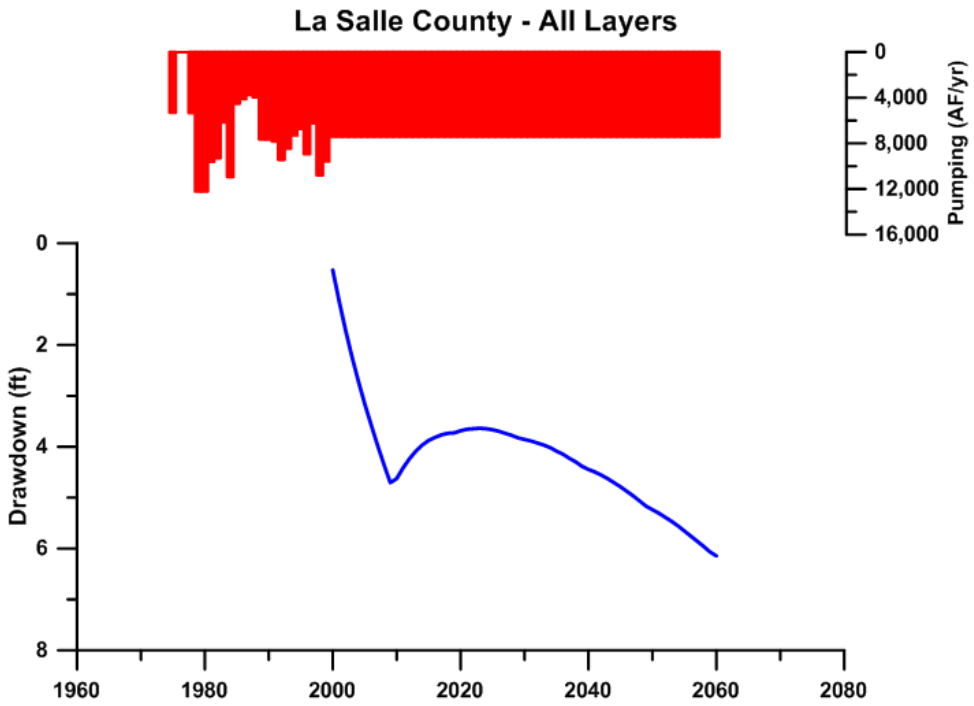

Figure 13. Summary of Pumping and Drawdown - La Salle County

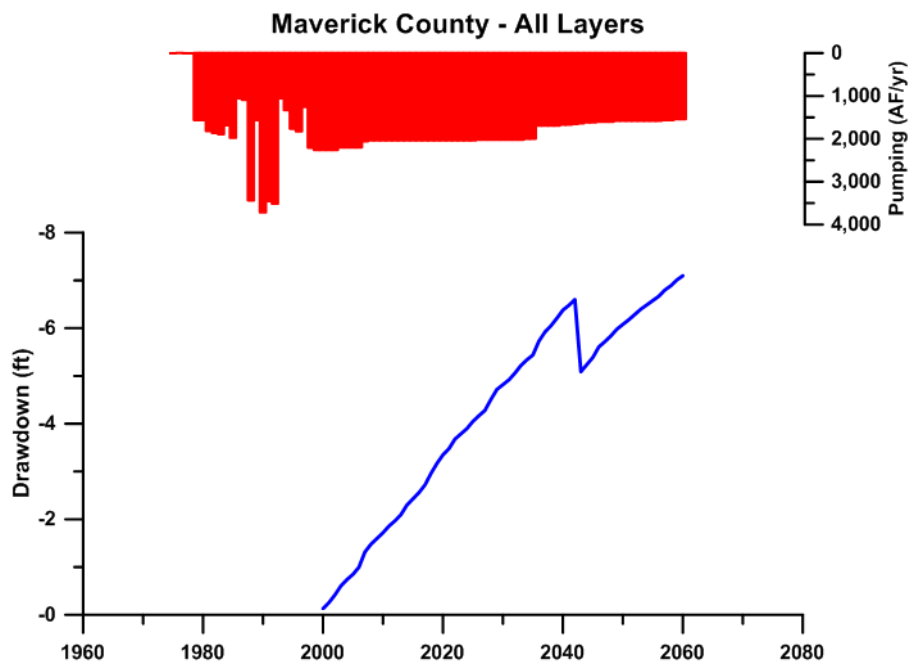

Figure 14. Summary of Pumping and Drawdown - Maverick County

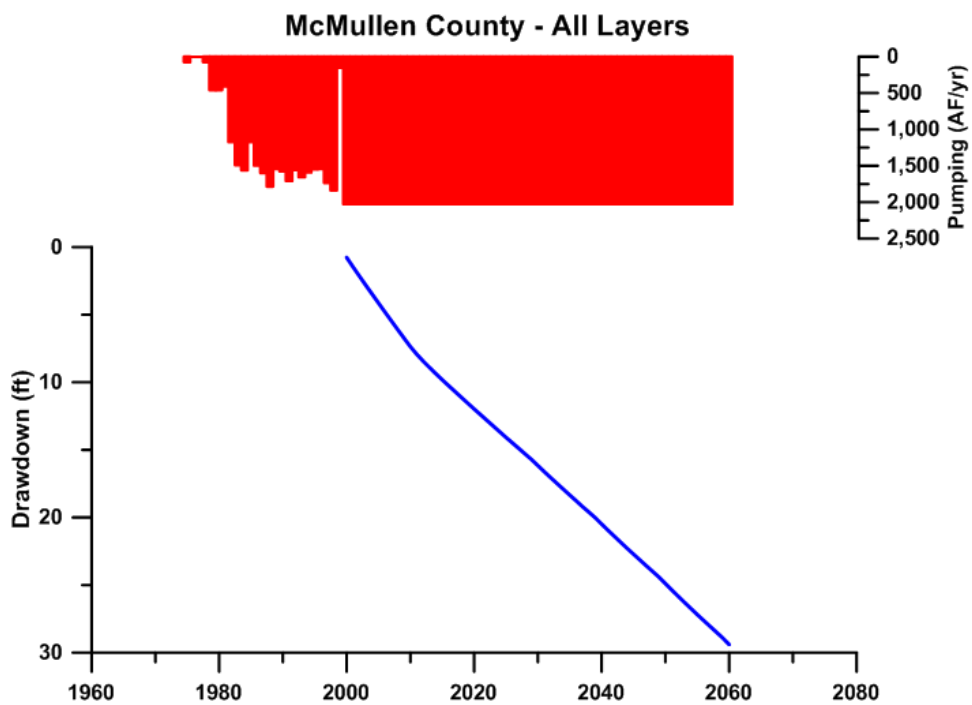

Figure 15. Summary of Pumping and Drawdown - McMullen County

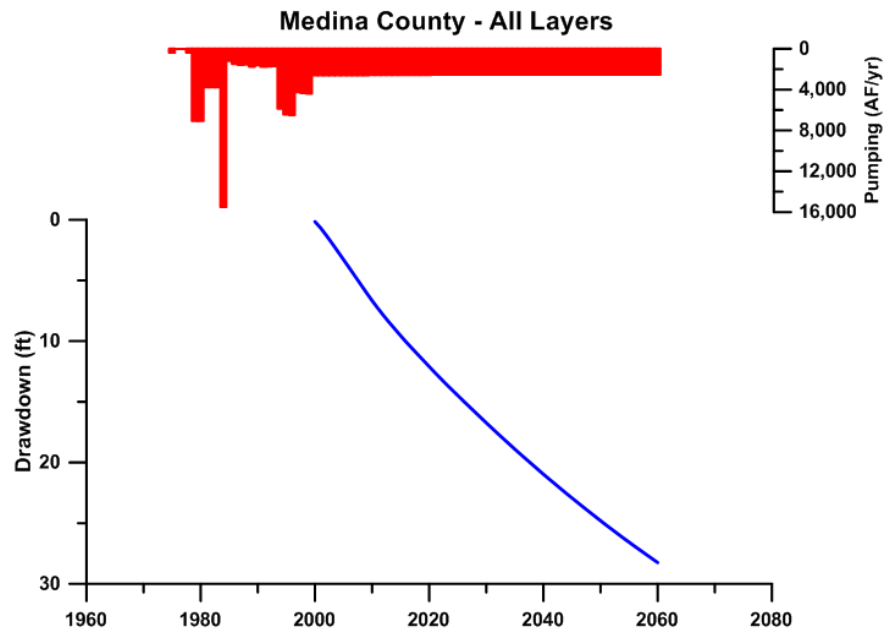

Figure 16. Summary of Pumping and Drawdown - Medina County

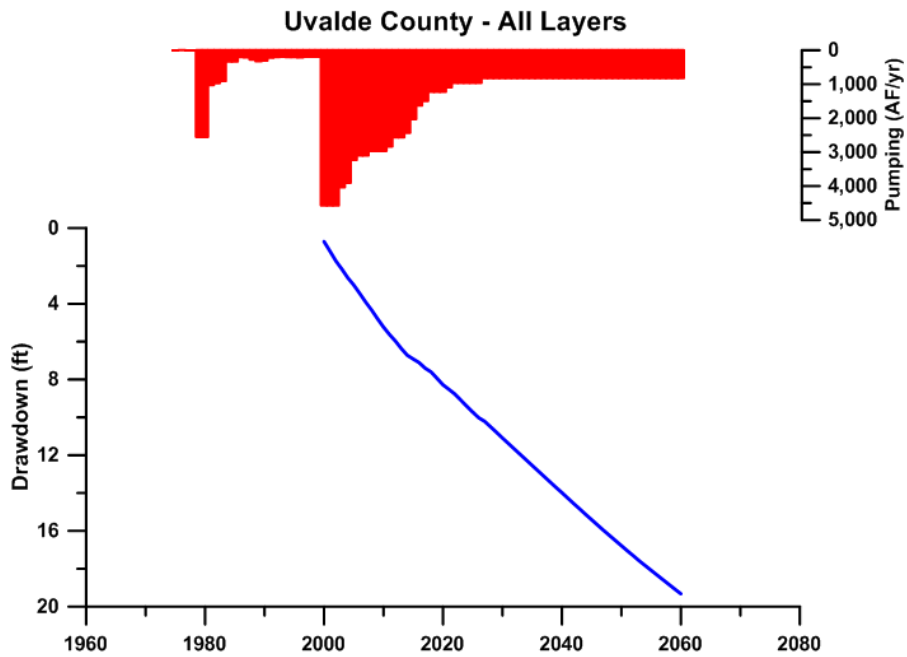

Figure 17. Summary of Pumping and Drawdown - Uvalde County

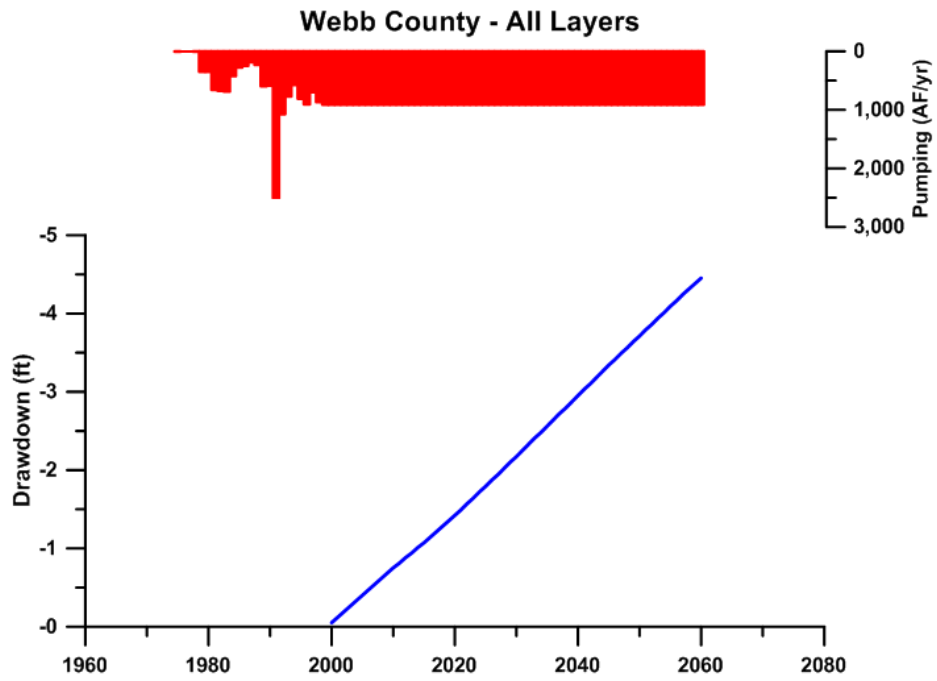

Figure 18. Summary of Pumping and Drawdown - Webb County

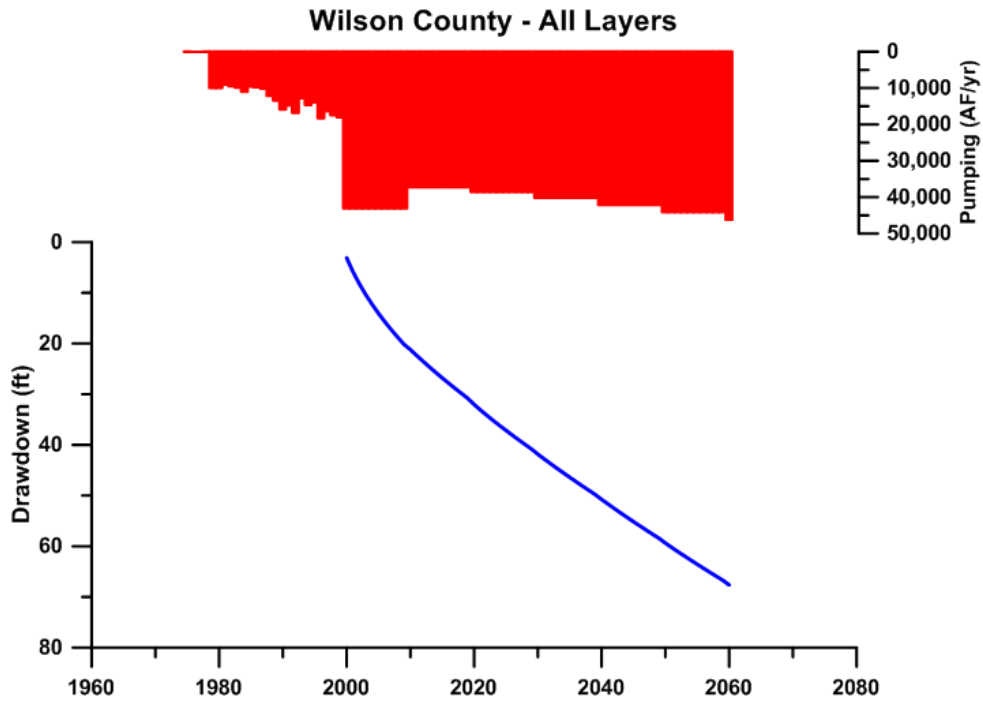

Figure 19. Summary of Pumping and Drawdown - Wilson County

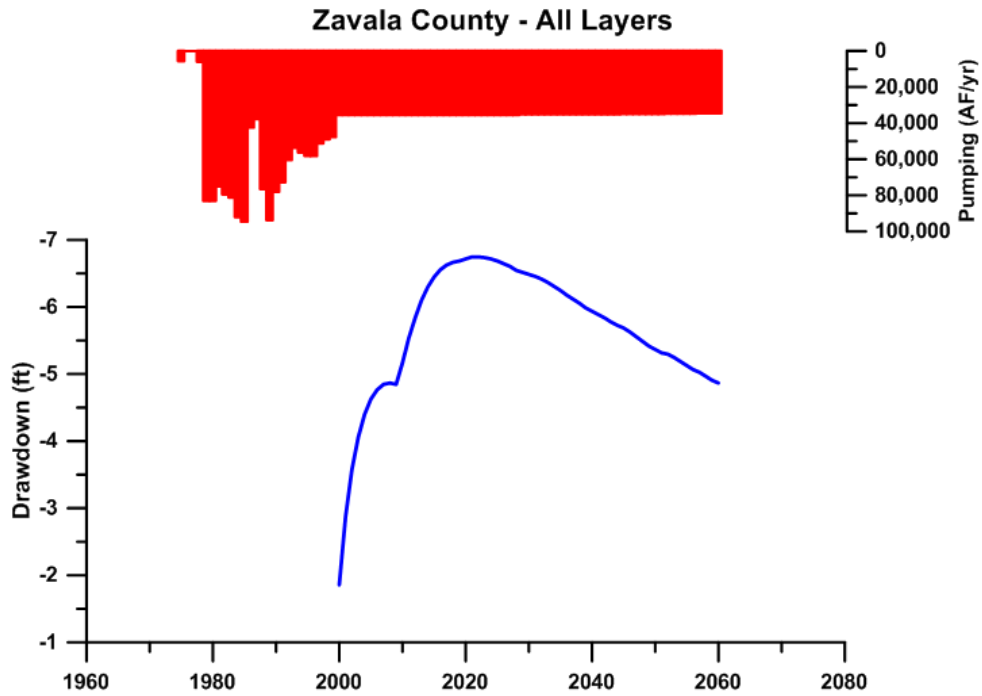

Figure 20. Summary of Pumping and Drawdown - Zavala County

Inspection of Figures 5 to 20 shows that, in some counties, groundwater pumping is expected to increase. Some of these increases were assumed to occur in 2000. Groundwater pumping is expected to be about the same as 1999 pumping in some counties. Finally, groundwater pumping is expected to decrease in some counties, and these decreases were assumed to begin in 2000. Also note the general correlation between pumping increases/decreases and groundwater elevation drawdown/recovery. There is also some observation of drawdown/recovery impacts of pumping changes across county lines. This is of particular interest in the joint planning process.

3.0 Point-by-Point Comparison of Groundwater Elevations

Historic groundwater elevation data were obtained from the Texas Water Development Board for use in this analysis. Data maintained in this database include well location (latitude and longitude), well depth, completion data (screen top and bottom depth), and groundwater elevation data. In GMA 13, the database contains 31,247 groundwater elevation measurements from 1906 to 2012 in 6,956 wells. However, in 5,112 wells there are no details of screened intervals, but many of these have an aquifer code. Of the 1,844 wells that have screened interval data, 574 wells have no groundwater elevation data, 695 have exactly one groundwater elevation data point, and 575 have two or more groundwater elevation measurements.

The wells with screened interval data were used in conjunction with the Groundwater Availability Model (GAM) for the Southern Carrizo-Wilcox, Queen City and Sparta aquifers. Each well was located in the model grid (i.e. row and column), and the completion interval was compared to the model layering data. Model data were then extracted for each cell with a well (e.g. aquifer parameters, historic and future pumping, and simulated groundwater elevations).

Based on this analysis, 748 wells in GMA 13 were selected as being completed in a single model layer. 412 wells had exactly one groundwater level measurement. 207 wells had five or more groundwater elevation measurements. 92 wells had 10 or more groundwater elevation measurements with at least one data point collected after the year 2000.

3.1 Hydrographs of Groundwater Elevations and Pumping

These 92 wells were used to construct hydrographs of groundwater elevation and pumping. The locations of these 92 wells are shown in Figure 21, and details of these 92 wells are presented in Table 3. Please note that Table 3 is sorted by county and well number, and includes details of screen elevation, period of available groundwater elevation measurements, and data on aquifer parameters from the GAM.

Hydrographs of these 92 wells are presented in individual appendices organized by county. These hydrographs include historic groundwater elevations data, future groundwater elevation data from the results of GAM Run 09-034, land surface elevation, screened intervals and historic and future pumping in three zones: 1) pumping within the cell where the well is located, 2) pumping in the cells immediately surrounding zone 1, and 3) pumping in cells immediately surrounding zone 2. Thus, pumping (both historic and projected) in a 25 square mile area surrounding the well of interest is presented in aid interpretation of the groundwater elevation changes. The appendices also present the locations of these wells, and contain data, maps and graphs from other analyses described later in this report.

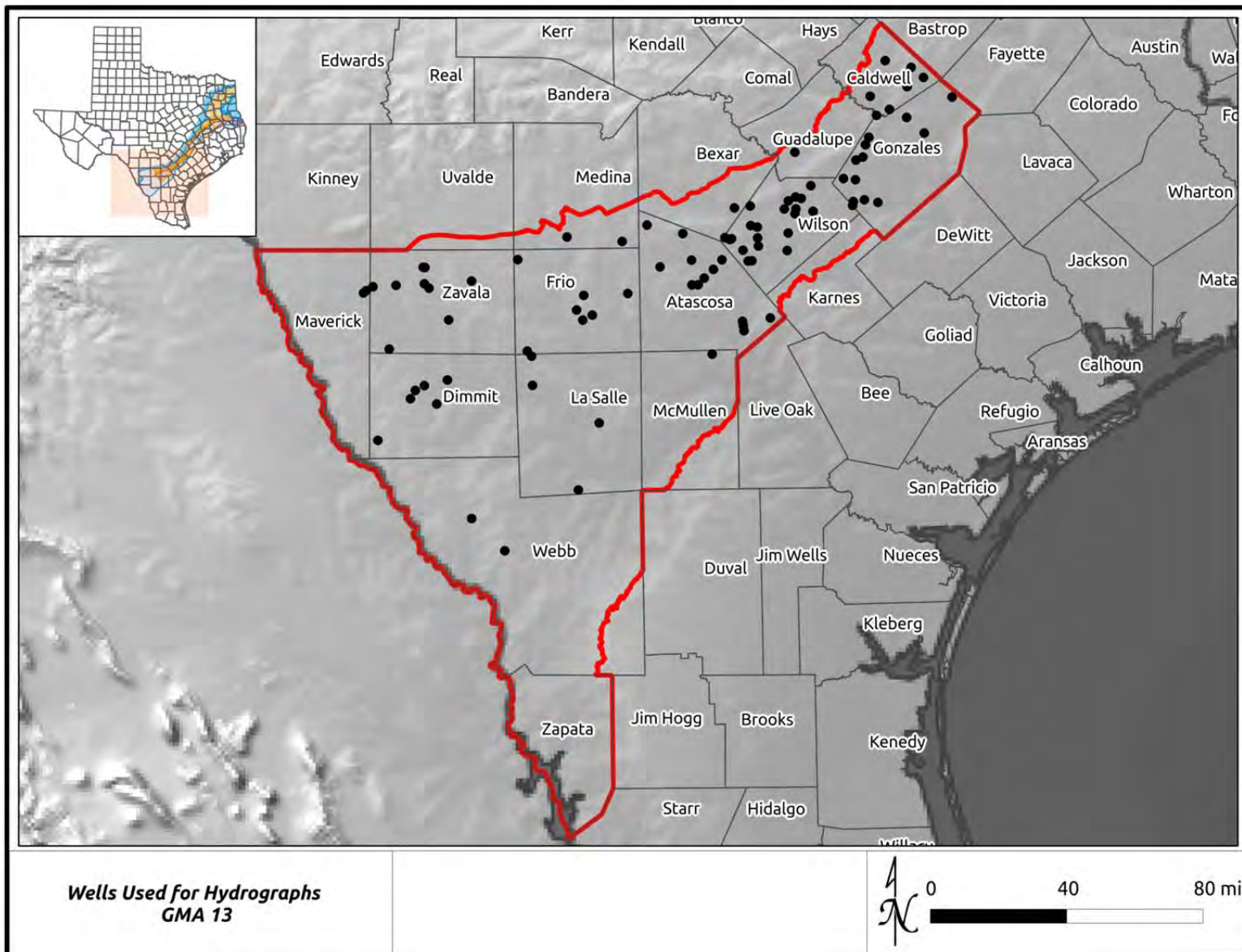

Figure 21. Map of Hydrograph Well Locations

Table 3. Summary Data for 92 Wells used in Hydrograph Construction

TWDB Well Number	County	TWDB Aquifer Code	Land Surface Elevation (ft MSL)	Well Depth (ft)	Elevation of Screen Top (ft MSL)	Elevation of Screen Bottom (ft MSL)	Model Row	Model Column	Model Layer	Well Use (TWDB Code)	Number of Groundwater Elevation Measurements	Earliest Year with Measurement	Latest Year with Measurement	Hydraulic Conductivity (ft/day)	Storativity (dimensionless)	Specific Yield (ft ⁻¹)	Elevation of Layer Top (ft MSL)	Elevation of Layer Bottom (ft MSL)
6850603	Atascosa	124WLCX	655	249	504	406	42	113	7	H	19	1969	2004	5.43	1.06E-03	0.1	628	276
6852713	Atascosa	124CRRZ	665	393	498	330	50	120	5	U	81	1970	2009	3.27	1.00E+00	0.15	691	296
6859804	Atascosa	124CRRZ	487	740	-56	-213	54	109	5	I	31	1964	2010	31.32	3.62E-03	0.15	5	-827
6860852	Atascosa	124CRRZ	470	1130	-460	-650	58	117	5	I	11	2000	2009	46.95	1.91E-03	0.15	-303	-810
6861905	Atascosa	124CRRZ	482	1413	-718	-931	63	125	5	I	40	1965	2010	20.75	3.11E-03	0.15	-433	-1268
7804508	Atascosa	124CRRZ	466	1850	-1234	-1344	64	113	5	U	89	2008	2012	13.51	1.92E-03	0.15	-967	-1586
7804612	Atascosa	124CRRZ	420	2125	-1286	-1518	65	115	5	P	15	1991	2010	14.06	2.39E-03	0.15	-1098	-1870
7805212	Atascosa	124CRRZ	405	1637	-957	-1232	64	121	5	I	13	1994	2010	27.04	3.10E-03	0.15	-706	-1562
7805409	Atascosa	124QNCT	380	800	-260	-420	64	117	3	P	31	1963	2010	4.53	5.17E-03	0.15	287	-698
7814801	Atascosa	124CRRZ	241	3992	-3239	-3319	82	118	5	U	20	1951	2010	14.78	2.03E-03	0.15	-2960	-4079
7814802	Atascosa	124CRRZ	233	3663	-3382	-3428	81	119	5	U	19	1951	2010	14.9	2.19E-03	0.15	-2825	-3982
7815805	Atascosa	124CRRZ	469	4359	-3851	-3888	85	126	5	P	27	1969	2010	40.44	1.36E-03	0.15	-3405	-4354
7822201	Atascosa	124CRRZ	228	4015	-3722	-3782	84	117	5	U	21	1951	2010	12.6	1.70E-03	0.15	-3240	-4258
6846702	Bexar	124WLCX	499	500	269	199	53	137	7	U	28	1970	2011	5.21	9.77E-04	0.1	522	197
6712111	Caldwell	124WLCX	472	175	332	312	45	198	8	S	48	1964	2011	8.12	9.76E-04	0.1	445	120
6713102	Caldwell	124WLCX	599	450	199	149	51	203	7	S	25	1964	2010	1	2.40E-03	0.1	444	-358
6713605	Caldwell	124CRRZ	490	470	60	40	55	204	5	H	24	1964	2009	24.52	2.02E-03	0.15	238	-198
6713702	Caldwell	124CRRZ	566	270	366	346	55	199	5	H	12	1963	2010	19.19	1.00E+00	0.15	502	139
6719306	Caldwell	124WLCX	475	330	292	145	51	188	8	U	49	1964	2011	6.23	1.71E-03	0.1	298	-273
6720802	Caldwell	124WLCX	410	200	241	221	57	191	7	S	50	1963	2010	1	2.68E-03	0.1	362	-531
7648801	Dimmit	124CRRZ	680	55	672	625	45	12	5	H	44	1965	2012	0.54	1.00E+00	0.15	690	613
7726708	Dimmit	124CRRZ	602	315	522	287	40	33	5	H	36	1969	2012	1.46	2.05E-03	0.15	550	256
7727709	Dimmit	124BGDF	525	99	459	445	43	39	3	U	32	1974	2012	2.28	1.00E+00	0.15	530	244
7733322	Dimmit	124CRRZ	665	263	560	518	40	30	5	G	61	1971	2004	2.86	1.00E+00	0.15	636	460
7733611	Dimmit	124CRRZ	690	360	650	330	41	27	5	H	39	1944	2012	5.94	1.00E+00	0.15	671	316
7734607	Dimmit	124CRRZ	565	601	215	-36	47	32	5	S	42	1957	2009	2.84	1.73E-03	0.15	217	-132
6961606	Frio	124CZWX	687	338	557	349	27	77	5	I	16	1981	2010	35.56	2.13E-03	0.15	589	266
7708803	Frio	124CRRZ	652	1352	-468	-548	47	86	5	U	254	1963	2011	50.82	2.60E-03	0.15	-415	-1118
7716409	Frio	124CRRZ	589	1392	-705	-800	49	82	5	I	19	1997	2006	31.67	1.54E-03	0.15	-696	-1155
7716603	Frio	124CRRZ	640	1785	-945	-1145	53	84	5	I	35	1963	2010	31.68	1.45E-03	0.15	-895	-1378
7716801	Frio	124CRRZ	521	1828	-1107	-1307	53	81	5	U	141	1952	2010	48.2	1.13E-03	0.15	-1037	-1404
7722703	Frio	124CRRZ	575	2000	-1185	-1425	50	63	5	I	10	2001	2010	20.1	1.01E-03	0.15	-1179	-1526
7802701	Frio	124CRRZ	553	1588	-647	-1035	54	97	5	H	17	1965	2002	30.78	1.89E-03	0.15	-638	-1214
6719901	Gonzales	124WLCX	360	230	150	130	56	186	7	U	37	1959	2010	20.5	2.06E-03	0.1	373	-312
6721703	Gonzales	124CRRZ	420	520	-54	-75	62	193	5	S	34	1967	2010	36.72	2.75E-03	0.15	-30	-713
6722301	Gonzales	124SPRT	366	600	-137	-234	65	207	1	H	36	1959	2010	1.79	1.14E-03	0.15	-130	-351
6727502	Gonzales	124CRRZ	435	180	280	259	60	181	5	U	29	1970	2010	18.43	1.90E-03	0.15	354	14
6727503	Gonzales	124WLCX	433	323	133	110	60	181	5	H	17	1979	2010	18.43	1.90E-03	0.15	354	14
6727805	Gonzales	124CRRZ	370	700	104	-148	61	179	5	U	99	1981	2010	21.82	2.19E-03	0.15	286	-149
6729602	Gonzales	124CRRZ	375	1685	-1245	-1310	69	195	4	S	29	1969	2010	1	1.52E-03	0.1	-1121	-1407
6735201	Gonzales	124CRRZ	493	800	-107	-307	64	176	5	I	20	1959	2010	55.81	2.38E-03	0.15	110	-451
6735401	Gonzales	124CRRZ	398	732	154	-174	63	174	5	I	25	1959	2010	23.67	2.41E-03	0.15	271	-235
6742202	Gonzales	124CRRZ	409	600	-91	-191	65	168	5	S	35	1963	2010	20.92	2.54E-03	0.15	98	-506
6742905	Gonzales	124CRRZ	375	1525	-1050	-1150	73	165	5	H	23	1959	2010	71.2	2.31E-03	0.15	-849	-1565
6742906	Gonzales	124CRRZ	390	1645	-1032	-1215	72	166	5	P	10	1968	2002	71.56	2.36E-03	0.15	-773	-1493
6743103	Gonzales	124CRRZ	380	1000	-420	-620	68	170	5	I	28	2000	2010	53.08	2.52E-03	0.15	-357	-1033
6743805	Gonzales	124CRRZ	365	1950	-1485	-1585	74	169	5	S	12	1959	2010	31.56	2.20E-03	0.15	-1032	-1748
6743903	Gonzales	124CRRZ	312	2530	-2018	-2218	77	172	5	P	13	2001	2005	17.56	2.13E-03	0.15	-1850	-2745
6840310	Guadalupe	124WLCX	585	130	475	455	50	161	8	U	40	1970	2011	7.37	5.27E-04	0.1	604	428
7722801	LaSalle	124LRDO	583	252	383	331	52	63	1	H	35	1962	2012	5.17	7.46E-04	0.15	512	289
7730801	LaSalle	124CRRZ	516	2051	-1284	-1535	59	58	5	H	44	1955	2007	11.26	9.80E-04	0.15	-1258	-1554
7748301	LaSalle	124CRRZ	420	3483	-2914	-3063	80	67	5	H	54	1956	2012	7.82	1.64E-03	0.15	-2541	-3278
7764401	LaSalle	124CRRZ	395	4280	-3535	-3885	92	50	5	H	45	1959	2012	2.7	1.41E-03	0.15	-3286	-4072
7607901	Maverick	124CRRZ	703	100	623	603	8	34	5	U	48	1955	2012	2.28	1.00E+00	0.15	715	602

Table 3. Summary Data for 92 Wells used in Hydrograph Construction

TWDB Well Number	County	TWDB Aquifer Code	Land Surface Elevation (ft MSL)	Well Depth (ft)	Elevation of Screen Top (ft MSL)	Elevation of Screen Bottom (ft MSL)	Model Row	Model Column	Model Layer	Well Use (TWDB Code)	Number of Groundwater Elevation Measurements	Earliest Year with Measurement	Latest Year with Measurement	Hydraulic Conductivity (ft/day)	Storativity (dimensionless)	Specific Yield (ft ⁻¹)	Elevation of Layer Top (ft MSL)	Elevation of Layer Bottom (ft MSL)
7607919	Maverick	124CRRZ	700	115	616	595	8	36	5	U	68	1971	2012	2.38	1.00E+00	0.15	697	560
7821801	McMullen	124CZWX	378	3600	-3122	-3212	83	106	5	H	42	1959	2012	10.98	1.27E-03	0.15	-3030	-3749
6857307	Medina	124CRRZ	643	409	517	329	41	104	5	U	71	1971	2011	15.51	1.00E+00	0.15	654	236
6955901	Medina	124WLCX	665	225	565	440	30	92	8	U	44	1952	2011	7.56	5.10E-04	0.1	572	402
8504401	Webb	124CRRZ	620	2000	-1222	-1272	80	20	5	H	33	1965	2012	0.79	7.07E-04	0.15	-1121	-1328
8513402	Webb	124LRDO	720	505	245	220	93	22	3	U	39	1965	2012	0.61	7.71E-03	0.15	255	-1365
6741102	Wilson	124CRRZ	590	272	340	318	61	159	5	U	141	1964	2010	23.1	2.49E-03	0.15	524	42
6749201	Wilson	124CRRZ	470	916	-341	-431	68	155	5	U	51	1963	2010	29.51	2.35E-03	0.15	-257	-890
6749202	Wilson	124QNCT	472	460	142	12	68	155	3	Z	33	1969	2010	1.74	1.00E+00	0.15	493	-93
6749206	Wilson	124CRRZ	467	972	-385	-485	68	155	5	P	10	2000	2010	29.51	2.35E-03	0.15	-257	-890
6846902	Wilson	124WLCX	517	692	-95	-175	55	141	8	U	17	1994	2010	5.57	1.57E-03	0.1	29	-495
6848601	Wilson	124CRRZ	490	202	438	288	61	153	5	H	39	1964	2010	11.38	1.00E+00	0.15	487	-78
6848812	Wilson	124CRRZ	426	533	239	134	61	151	5	U	73	1970	2010	25.99	2.11E-03	0.15	344	-84
6848907	Wilson	124CRRZ	502	340	312	162	62	154	5	I	30	1969	2010	13.22	3.24E-03	0.15	386	-227
6853902	Wilson	124CRRZ	533	754	-86	-221	58	129	5	I	13	1994	2010	40.9	3.43E-03	0.15	270	-491
6854602	Wilson	124CRRZ	525	200	367	325	60	137	4	U	40	1964	2010	1	1.00E+00	0.1	468	324
6855407	Wilson	124CRRZ	456	417	136	39	61	139	5	I	35	1969	2010	38.87	2.72E-03	0.15	224	-336
6855704	Wilson	124CRRZ	430	920	-190	-490	64	137	5	I	37	1969	2010	29.13	3.24E-03	0.15	-155	-896
6856101	Wilson	124CRRZ	490	280	233	211	62	148	5	U	44	1955	2010	41.07	2.61E-03	0.15	328	-217
6856201	Wilson	124CRRZ	428	800	-252	-372	65	150	5	I	36	1970	2010	76.86	2.23E-03	0.15	-69	-621
6856302	Wilson	124CRRZ	431	520	-27	-89	64	151	5	I	44	1964	2010	77.96	1.99E-03	0.15	22	-451
6856804	Wilson	124QNCT	489	460	251	29	68	145	3	I	37	1969	2010	2.05	3.70E-03	0.15	464	-184
6862104	Wilson	124CRRZ	590	925	-176	-330	60	130	5	U	198	1966	2012	56.07	3.23E-03	0.15	19	-753
6862108	Wilson	124CRRZ	572	938	-266	-366	60	131	5	H	14	1993	2010	42.25	3.06E-03	0.15	24	-693
6862503	Wilson	124QNCT	487	600	17	-113	64	131	3	H	36	1969	2010	2.28	3.55E-03	0.15	444	-272
6862902	Wilson	124CRRZ	437	1600	-1023	-1163	68	131	5	I	105	1955	2010	32.21	2.08E-03	0.15	-1001	-1691
6862906	Wilson	124CRRZ	422	1924	-1387	-1497	68	132	5	I	18	1991	2010	29.27	2.06E-03	0.15	-956	-1634
6863101	Wilson	124CRRZ	448	1210	-602	-762	66	136	5	U	43	1952	2010	33.2	2.46E-03	0.15	-482	-1190
6864402	Wilson	124CRRZ	403	2032	-1376	-1628	72	142	5	P	23	1954	2010	21.32	2.17E-03	0.15	-1206	-1978
6958701	Zavala	124CRRZ	772	182	671	604	13	53	5	U	147	1954	2012	2.12	1.00E+00	0.15	767	415
6958707	Zavala	124CRRZ	789	244	651	589	12	53	5	I	39	1958	2012	4.85	1.00E+00	0.15	785	542
7608406	Zavala	124CRRZ	712	102	647	610	8	38	5	U	23	1970	2012	2.04	1.00E+00	0.15	716	569
7624906	Zavala	124CRRZ	631	438	349	210	26	31	5	U	69	1971	2012	3.97	1.66E-03	0.15	451	174
7701404	Zavala	124CRRZ	735	189	581	550	12	43	5	S	26	1970	2003	5.7	8.82E-04	0.15	586	422
7702403	Zavala	124CRRZ	748	575	323	173	16	50	5	P	87	1964	2007	8.28	9.44E-04	0.15	326	111
7702509	Zavala	124CRRZ	735	734	121	1	18	51	5	U	209	2002	2012	10.45	1.32E-03	0.15	232	-61
7704431	Zavala	124CRRZ	708	807	41	-99	24	62	5	P	68	1968	2011	48.08	7.26E-04	0.15	47	-132
7711719	Zavala	124BGDF	640	865	-210	-220	29	50	4	U	41	1975	2012	1	2.04E-03	0.1	-32	-339

The hydrographs are useful to compare model calibration by comparing pre-1999 historic groundwater elevations to the estimates of groundwater elevation at that point (the black line). In many cases the comparison is favorable, in other areas it is not. The estimates of historic pumping in the vicinity of the well are sometimes a useful guide to interpret the comparisons. In general, the recovering future groundwater elevations are well correlated with assumed decreases in pumping, and declining future groundwater elevations are well correlated with assumed increases in pumping.

3.2 Well-by-Well Drawdown Comparison

In order to compare drawdown estimates from GAM Run 09-034 with drawdown data from specific wells, the group of wells used in hydrograph construction were filtered further to include wells that had a late 1999/early 2000 groundwater elevation measurement and at least one measurement at the end of the year/beginning of the year from late 2000/early 2001 to late 2011/early 2012. As a result of this additional filtering 70 wells with 628 groundwater drawdown measurements were identified that met these criteria. Locations of these wells are presented in Figure 22 and the selected details of the wells and the 628 actual drawdown measurements from 2000 to 2011 are presented in Table 4. Please note that blank entries in Table 4 represent years where no data were collected.

The comparison of actual drawdown and model-estimated drawdown was completed by calculating the difference between the model-estimated drawdown and actual drawdown. A positive number means that the actual groundwater elevation is higher than the groundwater elevation projected by GAM Run 09-034 in that cell of the model. For example, if the drawdown from GAM Run 09-034 is 10 feet, and the actual drawdown is 8 feet, the difference is 2 feet, which means that the groundwater elevation is two feet higher than projected in GAM Run 09-034. Conversely, a negative number from this calculation means that actual groundwater elevations are lower than the estimated groundwater elevation from GAM Run 09-034. Results were summarized by GMA, year, and county.

The overall summary of the analysis for GMA 13 is shown in Figure 23, which is a histogram of the difference between DFC drawdown and actual drawdown for all years evaluated (2000 to 2011). Maps showing this analysis for each year for GMA 13 are presented in Appendix 1. More detailed maps for 2001, 2006 and 2011 which include well numbers for each county are presented in the county-specific appendices.

Please note that a difference of greater than 3 feet (actual groundwater elevation is 3 feet or more higher than the DFC simulation elevation) is shown in green, differences of between -3 and 3 feet are shown in yellow (actual groundwater elevation and DFC simulation elevation is within 3 feet), and differences less than -3 feet are shown in red (actual groundwater elevation is 3 feet or lower than the DFC simulation elevation). From this plot, it can be seen that about 18 percent of all groundwater elevation measurements are below the projected groundwater elevation from the DFC condition, about 25 percent are within 3 feet of the DFC condition, and about 57 percent are 3 feet or higher than the DFC condition.

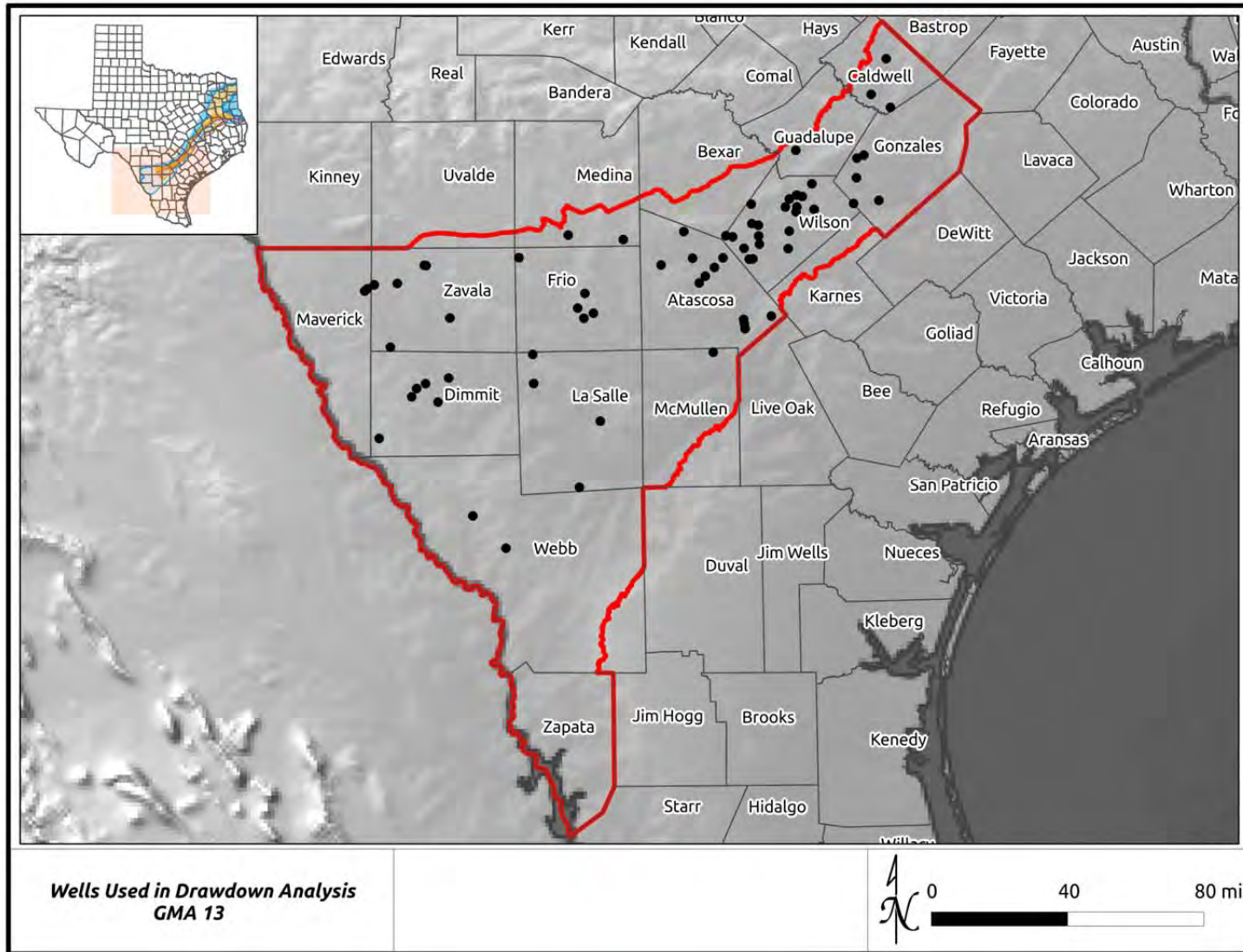

Figure 22. Locations of Wells Used in Drawdown Comparison

Table 4. Wells Used in Drawdown Comparison

Well Number	County	Model Row	Model Column	Model Layer	Measured Drawdown from 1999 Groundwater Level (ft) by Year												
					2000	2001	2002	2003	2004	2005	2006	2007	2008	2009	2010	2011	
6852713	Atascosa	50	120	5	0.50	0.10	-2.20	-2.80	-3.50	-0.90	-2.30	-2.90	-4.30	-6.00			
6859804	Atascosa	54	109	5	3.20	4.00	3.00	0.50	0.75	2.50	3.60	1.60	2.50				
6860852	Atascosa	58	117	5		-5.15	-11.95	-9.45	-20.35	-22.15	-22.05	-30.35	-34.65	-40.05			
6861905	Atascosa	63	125	5	-2.70	11.40	-1.00	-1.50	-23.00	-6.00	-9.00	-7.40	-2.00				
7804612	Atascosa	65	115	5	-0.90	10.80	6.20	4.40	4.80	7.40	9.20	6.40	7.80	5.80			
7805212	Atascosa	64	121	5		2.10	0.90	1.70	1.50	3.90	5.80	5.20	5.70	4.70			
7805409	Atascosa	64	117	3		2.00	0.10	0.50	4.40	5.70	10.40	5.90	7.30	5.60			
7814801	Atascosa	82	118	5	16.15	22.85	-4.18	-0.72	-0.72	1.59	10.83	9.68	15.50	10.80			
7814802	Atascosa	81	119	5	11.55	17.33	11.55	13.90	11.55	12.71	17.33	15.02	13.90	13.90			
7815805	Atascosa	85	126	5	14.00	12.30	11.60	10.30	9.30	10.60	6.10	9.10	10.00				
7822201	Atascosa	84	117	5	0.42	5.04	5.04	3.88	-0.74	0.42	2.04	-2.12	-0.70	0.20			
6712111	Caldwell	45	198	8	-0.10	-0.90	-2.47	-3.15	-3.83	-1.95	-1.50	-0.60	-0.30	0.60	1.62	0.75	
6719306	Caldwell	51	188	8	-3.44	-3.16	-4.16	-3.84	-6.31	-3.24	-8.71	-3.44	-3.16	-2.66	-0.82	-0.04	
6720802	Caldwell	57	191	7	0.93	-0.93	-1.95	2.48	-0.52	-2.27	-1.15	0.18	0.75	-0.01			
7648801	Dimmit	45	12	5	0.20	0.48			-0.53	0.03	0.28	0.70	-0.40	0.23	0.66	10.75	
7726708	Dimmit	40	33	5	1.40	1.34	2.11	0.43	1.39	13.65	4.00	5.50		8.08	7.71	10.94	
7727709	Dimmit	43	39	3	0.60	1.20	0.68	0.80	0.03	1.65	2.80	0.70	2.71	6.36	5.01	4.75	
7733322	Dimmit	40	30	5	0.00	0.78	-5.96	2.00									
7733611	Dimmit	41	27	5	-3.20	-1.46	-2.93	6.40	-0.83	0.82	1.59		5.53		3.87	6.03	
7734607	Dimmit	47	32	5		10.10	6.95	-12.90					-10.00				
6961606	Frio	27	77	5	1.50	6.60	-8.00	-5.50	-9.00	-0.20	11.00	0.60	0.60				
7708803	Frio	47	86	5	-13.20	47.82	-10.61	-16.97	-31.81	46.55	32.35	49.32	68.22	15.31	85.85		
7716409	Frio	49	82	5	-33.00	-28.00											
7716603	Frio	53	84	5		31.00	18.10	12.00	11.40	16.60	21.30	17.04	32.50	24.50			
7716801	Frio	53	81	5		35.90	-8.80	-1.70	-12.28	23.40	37.60	16.40	61.00	25.20			
6735201	Gonzales	64	176	5		2.17		5.94	4.54	7.94		6.77		14.75			
6735401	Gonzales	63	174	5		2.42		5.55	6.62	7.70		7.33		10.19			
6742905	Gonzales	73	165	5		7.86		12.58	11.39	13.82		13.45		16.94			
6743103	Gonzales	68	170	5	0.19	5.65		17.58	16.90	21.39		23.27		23.51			
6743903	Gonzales	77	172	5	0.00	50.40											
6840310	Guadalupe	50	161	8	-0.65	-0.30	-0.52	0.00	-0.82	0.00	-0.62	-0.15	-0.30		1.36	0.41	
7722801	LaSalle	52	63	1	1.70	1.05	0.80	0.90	-0.62	12.70	2.70	2.40	4.77	2.12	-1.76	-3.70	
7730801	LaSalle	59	58	5	-0.20	5.80	-8.60	-1.80									
7748301	LaSalle	80	67	5	10.70	6.14	8.22	6.30	-14.85	-6.53	12.00	10.90	19.56	38.44	45.22	95.89	
7764401	LaSalle	92	50	5	15.15	0.40	8.32			10.65	5.95		11.28		58.59	78.21	
7607901	Maverick	8	34	5		-7.73	-7.25	-6.45	-2.54	-1.58	-3.05	-4.70	-1.32	-1.07	-7.94	-7.34	
7607919	Maverick	8	36	5		-1.90	-1.35	-1.94	-2.35	-1.35	-1.70	-0.52	0.21	0.40	-0.03	-0.69	
7821801	McMullen	83	106	5	8.55	7.17					-0.95	12.70	0.08	8.40	8.42	9.56	54.48
6857307	Medina	41	104	5		1.82	3.40	4.40	4.28	6.09	7.22	8.18	9.73	8.38	9.06	9.55	
6955901	Medina	30	92	8	-0.07	0.27	-4.32	-3.41	-5.13	-0.17	6.46	6.73	6.75	4.81	10.74	3.63	
8504401	Webb	80	20	5		7.74	9.38		12.90		28.40					71.80	
8513402	Webb	93	22	3	3.94	1.37		4.04	-3.00	-0.60	4.05	3.84		19.19	21.27	25.79	

Table 4. Wells Used in Drawdown Comparison

Well Number	County	Model Row	Model Column	Model Layer	Measured Drawdown from 1999 Groundwater Level (ft) by Year											
					2000	2001	2002	2003	2004	2005	2006	2007	2008	2009	2010	2011
6741102	Wilson	61	159	5	0.00	-0.20	0.40	-0.80	1.40	1.80	2.50	2.20	0.70	3.10		
6749201	Wilson	68	155	5	0.00	-2.80	-1.60	0.20	-1.10	6.40	7.10	3.50	5.50	5.00		
6749202	Wilson	68	155	3	0.00	-0.20	5.90	3.30	1.40	-0.20	2.70	4.40	4.80	3.39		
6749206	Wilson	68	155	5		0.10	5.40	1.00	-0.80	0.00	4.00	1.20	3.80	3.25		
6846902	Wilson	55	141	8	-1.30	-1.70	-6.00	-6.70	-6.50	-3.20	-2.40	-3.90	-3.00			
6848601	Wilson	61	153	5	0.10	1.60	0.80	1.20	0.40	1.60	2.60	1.40	2.50			
6848812	Wilson	61	151	5	0.20	2.00	-0.80	1.50	-0.70	2.70	4.00	3.10	3.50			
6848907	Wilson	62	154	5	-3.40	-8.80	-4.50	-15.50	-17.40	-17.80	-16.00	-16.80	-16.20			
6853902	Wilson	58	129	5	-0.70	4.10	-10.00	-7.70	-32.60	-22.00	-4.30	-49.30	-3.90			
6854602	Wilson	60	137	4	0.10	2.40	0.60	0.80	-1.40	0.20	-0.20	-7.60	-10.70			
6855407	Wilson	61	139	5	0.90	2.80	1.20	1.90	-0.70	2.50	3.50	-0.20	0.20			
6855704	Wilson	64	137	5	-1.60	0.50	-0.90	-1.20	-2.80	-0.90	0.60	-1.40	0.10			
6856101	Wilson	62	148	5	0.20	4.80	3.50	3.80	1.60	2.40	3.30	0.80	2.10			
6856201	Wilson	65	150	5	-2.20	3.00	3.00	3.20	2.20	12.00	6.25	5.60	6.30			
6856302	Wilson	64	151	5	0.10	0.10	-0.40	-0.20	-2.20	-0.40	0.35	-0.50	0.20			
6856804	Wilson	68	145	3	0.10	2.85	8.00	7.10	0.60	6.40	8.10	6.80	8.10			
6862108	Wilson	60	131	5	-2.30	3.20	5.20	4.70	-7.00	-3.20	0.00	-18.20	-9.70			
6862503	Wilson	64	131	3	0.00	2.00	1.40	-2.50	-10.00	-7.50	-0.50	-2.70	0.50			
6862902	Wilson	68	131	5	0.80	3.50	0.40	-1.20	-9.00	-3.00	3.00	-1.20	1.60			
6862906	Wilson	68	132	5	3.00	5.75	1.50	-0.10	-8.30	3.50	7.00	4.60	6.69			
6863101	Wilson	66	136	5	0.05	3.00	1.60	2.00	1.20	2.40	3.00	1.90	3.60			
6864402	Wilson	72	142	5	0.25	-2.00	-5.00	-3.70	-7.20	-1.50	5.40	2.60	4.10			
6958701	Zavala	13	53	5	-8.95	-8.80	-3.40	-8.55	-8.53	-8.43	-8.01	-6.85	-5.28	-6.08	-5.13	-4.34
6958707	Zavala	12	53	5	-1.45	-1.00	-2.00	-2.56	-2.86	-2.57	-1.76	-1.30	-0.95	4.25	2.24	0.12
7608406	Zavala	8	38	5	5.10	1.00	1.90	1.05			1.65	6.55		14.58	9.16	8.90
7624906	Zavala	26	31	5	0.90	3.40	0.60	5.30	3.57	5.87	6.90	8.22	8.10	14.59	11.44	13.50
7701404	Zavala	12	43	5			-12.95									
7711719	Zavala	29	50	4	7.40	36.30	18.35	-0.90	-21.20	-0.42	17.80				-15.55	88.33

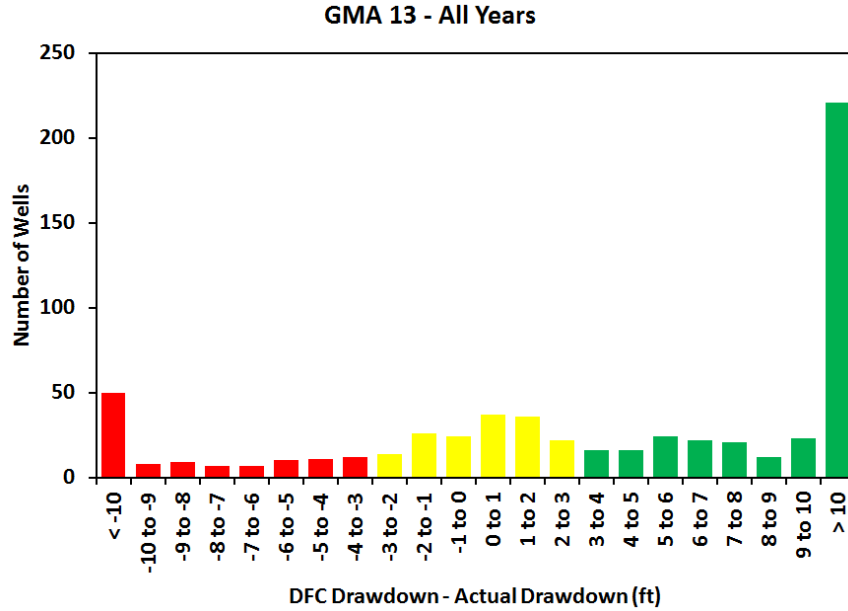

Figure 23. Summary of Differences between DFC Drawdown and Actual Drawdown for All Years

Figure 24 summarizes the data for all of GMA 13 for each year. Note that most in the early years (2000 and 2001), the majority of actual drawdowns are within 3 feet of the DFC condition. From 2002 to 2008, the majority of readings are more than 3 feet above the DFC conditions. From 2009 to 2011, the number of readings decreases significantly, and by 2011, the majority of actual drawdowns are greater than the DFC condition.

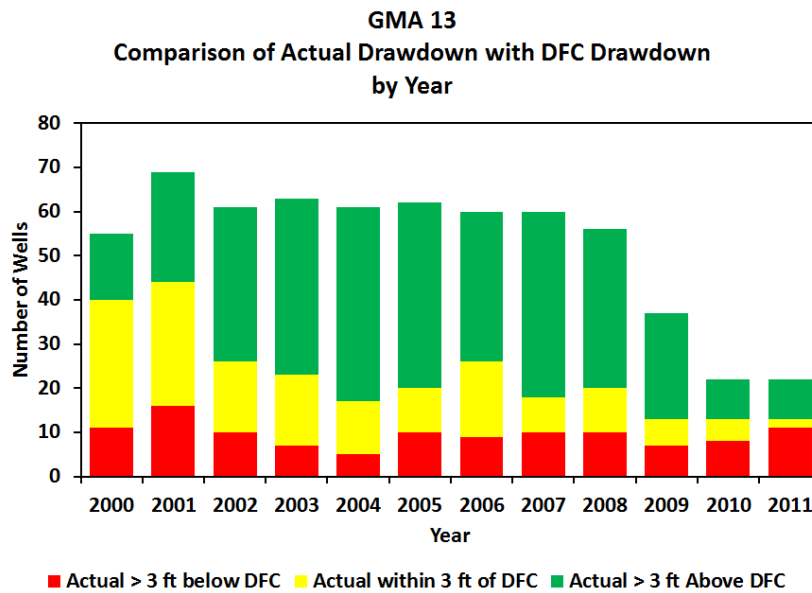

Figure 24. Comparison of Actual Drawdown with DFC Drawdown by Year – GMA 13

3.3 Average Drawdown Comparison

The analysis was extended by averaging all actual drawdowns in a particular year, all DFC condition drawdowns at wells with data for a particular year, the difference between the DFC condition and the actual drawdown, and comparing the results with county-wide average drawdown from GMA Run 09-034 and rainfall data. These results are summarized in Table 5 for GMA 13. Similar tables for each county are presented in the appendices.

Table 5. Summary of GMA 13 Drawdown Comparisons

<i>Column 1</i>	<i>Column 2</i>	<i>Column 3</i>	<i>Column 4</i>	<i>Column 5</i>	<i>Column 6</i>	<i>Column 7</i>
Year	Precipitation (% Avg)	GMA-Wide Average DFC	Number of Actual Drawdown Data Points	Average Actual Drawdown for Wells with Data	Average DFC for Wells with Data	Column 6 minus Column 5
2000	90	1.22	55	0.55	3.06	2.50
2001	101	2.23	69	4.79	6.25	1.46
2002	113	3.09	61	0.37	5.75	5.38
2003	96	3.87	63	0.47	9.02	8.55
2004	132	4.59	61	-2.77	10.78	13.55
2005	75	5.28	62	2.53	12.30	9.77
2006	86	5.93	60	4.37	11.33	6.96
2007	142	6.56	60	1.95	15.59	13.64
2008	74	7.16	56	4.47	14.81	10.34
2009	76	7.74	37	7.05	18.43	11.38
2010	132	7.78	22	11.46	7.87	-3.59
2011	45	7.93	22	21.26	7.03	-14.23

Figure 25 presents the data from Table 5 in histogram form, and includes the average annual precipitation. Similar histograms are presented for each county in the appendices. Note that in 2001 and 2002, the difference is less than 3 feet, and the color bar is yellow. From 2002 to 2009, the differences are all great than 3 feet (actual drawdown is less than DFC drawdown) and the bars are green. In 2010 and 2011, the differences are less than -3 feet (actual drawdown is less than DFC drawdown) and the bars are red.

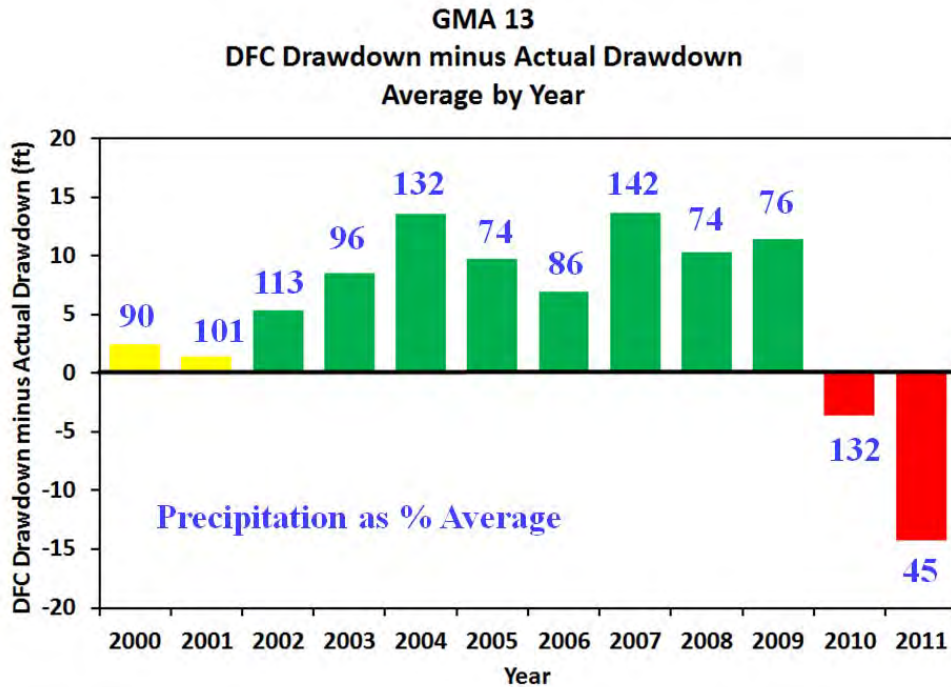

Figure 25. DFC Drawdown minus Actual Drawdown, Average by Year - GMA 13

The close agreement between actual drawdown and DFC drawdown in 2000 and 2001 is not surprising given the short time from the initial condition (1999) and the near-average precipitation. From 2002 to 2004, there is a general increase in actual groundwater elevations relative to the simulated DFC condition. This is partly due to the assumed pumping increases in much of GMA 13 that did not occur, and the relatively high precipitation conditions. This trend is interrupted in 2005 and 2006 when low precipitation occurred. The low precipitation conditions likely result in increased pumping due to the lack of rainfall as well as decreased recharge. In 2007, high precipitation again caused an increase in groundwater elevations, likely due to increased recharge and lower pumping. In 2008 and 2009, a return of low precipitation condition causes groundwater levels to fall relative to the DFC condition, again likely due to the combined effects of decreased recharge and increased pumping. Finally, in 2010 and 2011, groundwater levels drop to below that of the DFC condition. In both of these years, please recall that the number of readings is substantially lower than in previous years (see Table 5). This may affect the data, but other factors also need to be considered. 2010 is interesting because it was a relatively wet year, but it was also one of the first years of increased pumping due to hydraulic fracturing operations in the region. The large difference in 2011 appears to be explainable by considering the continuation/expansion of hydraulic fracturing operations and the severe drought year.

Figure 26 presents the actual drawdown data and the two sets of DFC data (full GMA average and estimated drawdown at the wells used in the analysis) from Table 5 in hydrograph form. Similar graphs for each county are presented in the appendices.

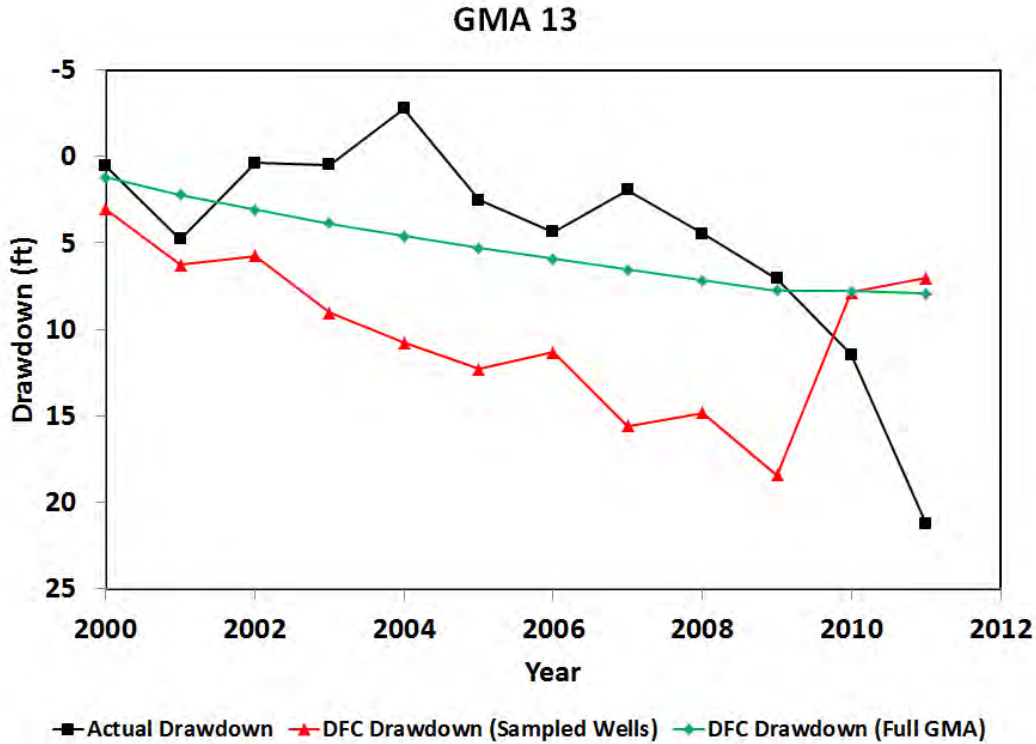

Figure 26. Hydrograph of Average Actual Drawdown and Average DFC Drawdown

Note that the actual drawdown in the wells with data is less than the drawdown estimated from the DFC simulation (Scenario 4 of GAM Run 09-034). The exception to this generalization is in 2010 and 2011. As discussed above, this is due to a combination of increased pumping during drought conditions, increased pumping due to hydraulic fracturing operations, decreased recharge due to drought (in 2011) and skewed results due to a smaller dataset. For future planning efforts, it appears that simulations of “constant” recharge and “constant” pumping may not be appropriate.

Also, please note that the DFC drawdown for the entire GMA (the green line) is generally larger than the DFC drawdown for the wells used in the analysis (the red line) until 2010 and 2011. Recall that fewer wells had measurements in 2010 and 2011 than the period 2000 to 2009. The fact that the DFC drawdowns for the wells used in the analysis (the red line) are lower than the overall GMA-wide average drawdown (green line) suggests that the wells used in the analysis are in areas where pumping increases were planned. It appears that data were not collected in many of these wells in 2010 and 2011, and the drawdown estimates are closer together.

4.0 County-Level Data Suitable for use in Management Plan Updates

One of the objectives of this effort was to develop data and information useful for the districts in their updates to groundwater management plans. One of the required elements of those plans is to address desired future conditions. The main body of the report focused on GMA-level analyses with various tables, maps and graphs.

Pertinent tables, maps and graphs were also developed for each county in GMA 13 for which suitable well data were available. These data are presented in the appendices (one for each county).

In general, the appendices contain:

- A map of the location of wells used in the hydrograph analysis
- The hydrographs of all wells that met the criteria previously described,
- A table analogous to Table 5 in the text summarizing annual average drawdown (actual and DFC)
- A figure analogous to Figure 23 in text showing differences between actual drawdown and DFC conditions
- A figure analogous to Figure 26 in text showing time history of drawdown (actual and DFC) from 2000 to 2011

5.0 Recommendations for Current Round of Joint Planning

This effort was authorized by the groundwater conservation districts of GMA 13 as the initial step of the current round of joint planning. The establishment of the initial desired future conditions for the Carrizo-Wilcox, Queen City and Sparta aquifers relied heavily on simulations using the groundwater availability model of the area. Comparisons of these model results with actual data provide a foundation for future discussions related to the current round of joint planning. The major areas for discussion include:

- Improvement in 2000 to 2011 pumping estimates
- Timing of future pumping increases and decreases
- Evaluate the “average” recharge assumption for the entire DFC simulation
- Evaluate the assumption that future pumping does not vary between wet years and droughts
- Review model assumptions and implementation for recharge and stream flow
- Assess county-to-county impacts more explicitly
- The use of actual well data as part of the statement of desired future conditions

In reviewing the results of the comparisons between groundwater elevations and pumping in general, and between actual groundwater elevations and groundwater elevations estimated through the joint planning process, it is evident that the future pumping assumptions used in Scenario 4 of GAM Run 09-034 from 2000 to 2011 need updating for the current round of joint planning. Projected increases and decreases are envisioned and the timing of those changes needs to be better incorporated into the planning process.

The comparison analysis also yielded interesting observations regarding the variation in groundwater elevations from wet years to dry years. Sharp declines in dry years appear to be the result of the combined effect of decreased recharge and increased pumping during drought periods. Scenario 4 of GAM Run 09-034 included an assumption that recharge was constant and “average” each year of the 61 year simulation. Also, there was no assumption of pumping variation as a result of dry years. For a long-term planning process, this may be the most cost-effective means of simulating future conditions. However, it is a point that should be discussed in the context of how much detail the desired future condition statement will contain.

In reviewing the results of the analysis, there were a few examples where the model results identified some county-to-county impacts of pumping changes that seemed to be consistent with the conceptual model and others that may have been a result of model implementation. These should be investigated further as part of the joint planning process to assure that the model simulations of the desired future condition are rational and defensible.

A discussion that needs to occur is how actual well data could be incorporated into the desired future condition statement and the role of the model in the process. It needs to be recognized that a model run, while not an absolute requirement, is certainly going to be made by the TWDB in the development of the Modeled Available Groundwater. Therefore, the groundwater conservation districts should realize that the GAM will continue to be an important aspect of the process. By linking the model run results to the desired future condition statement, however, the

issues of whether to describe the DFC as a single GMA-wide average or as county-averaged DFCs, or as county-layer averaged DFCs is somewhat irrelevant since all describe the same set of assumptions that are explicitly and implicitly tied to the DFC. The decision on how to express the DFC statement in terms of averaging and the decision to include or not include actual data will be policy decisions by the groundwater conservation districts of GMA 13. The data and results in this analysis will assist the districts in those decisions.

Appendix 1 – GMA 13 Drawdown Maps for All Years

This appendix presents GMA-wide maps of the point-by-point year-by-year drawdown analysis. These maps provide a GMA-wide perspective of the drawdown comparison. Each well on these maps is color coded to show the difference between actual drawdown and the estimated drawdown at that point in that year.

- A difference of greater than 3 feet (actual groundwater elevation is 3 feet or more higher than the DFC simulation elevation) is shown in green
- Differences of between -3 and 3 feet are shown in yellow (actual groundwater elevation and DFC simulation elevation is within 3 feet)
- Differences less than -3 feet are shown in red (actual groundwater elevation is 3 feet or lower than the DFC simulation elevation).

Detailed maps for each county using the same color coding for 2001, 2006 and 2011 (with well numbers) are presented in the appropriate county appendix.

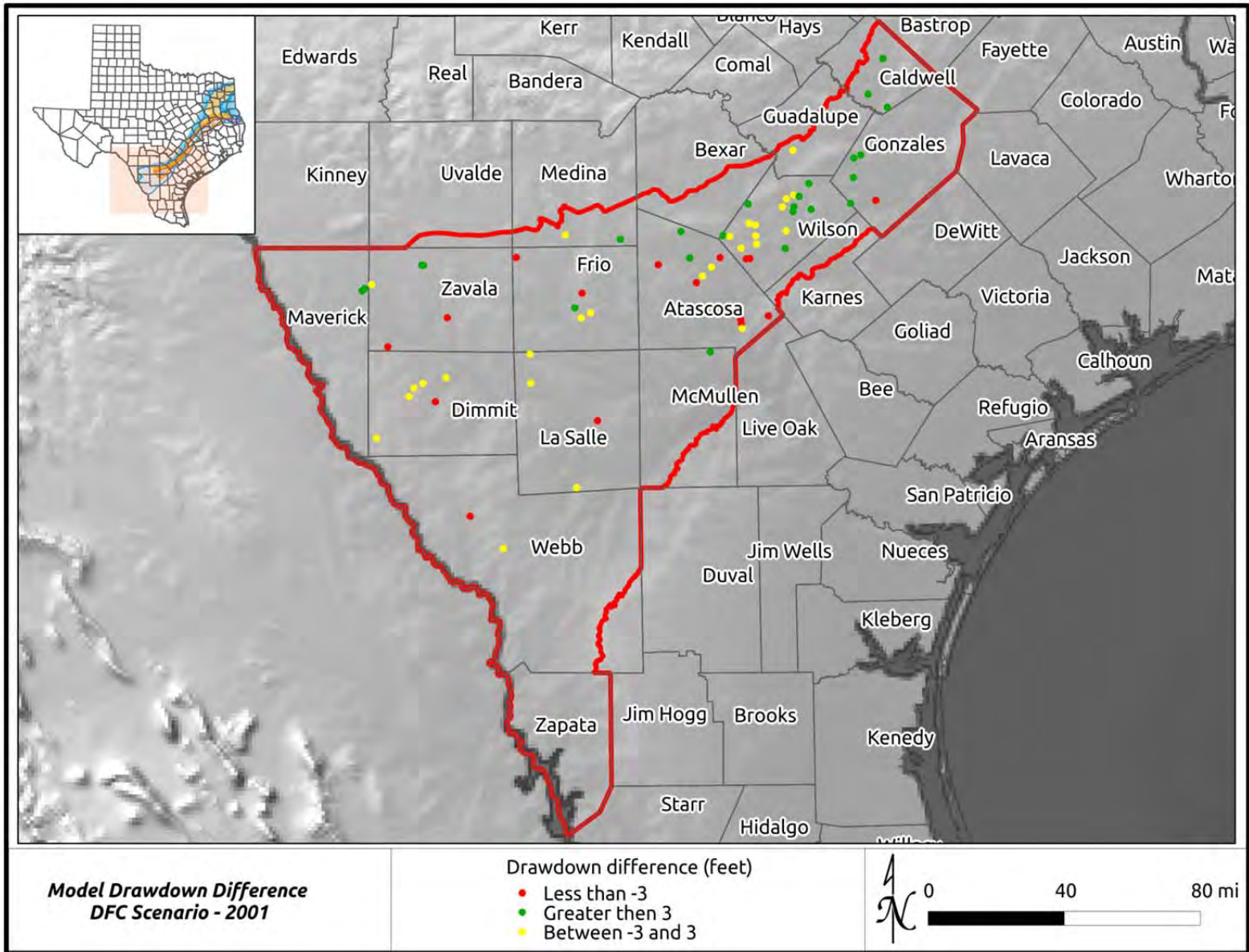

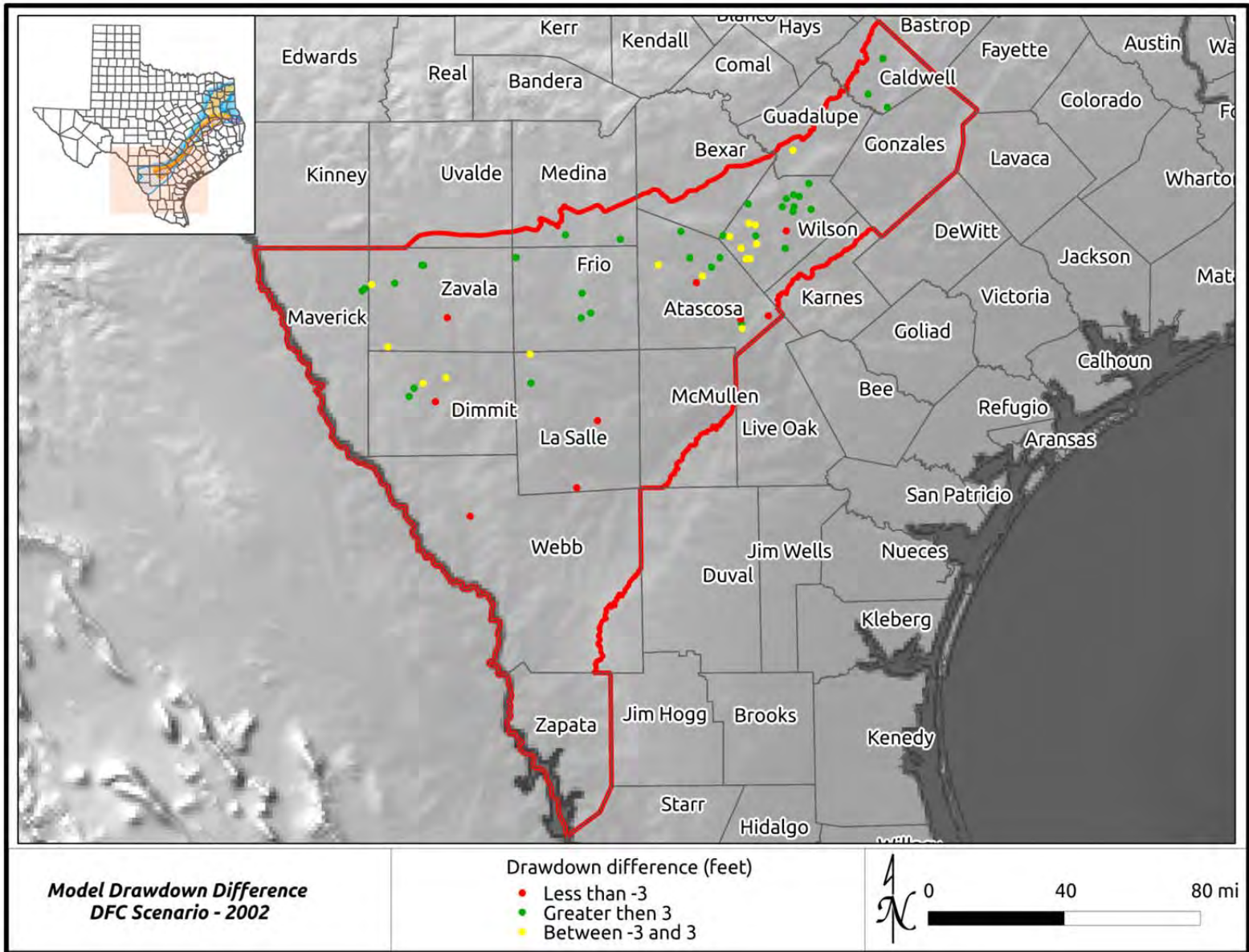

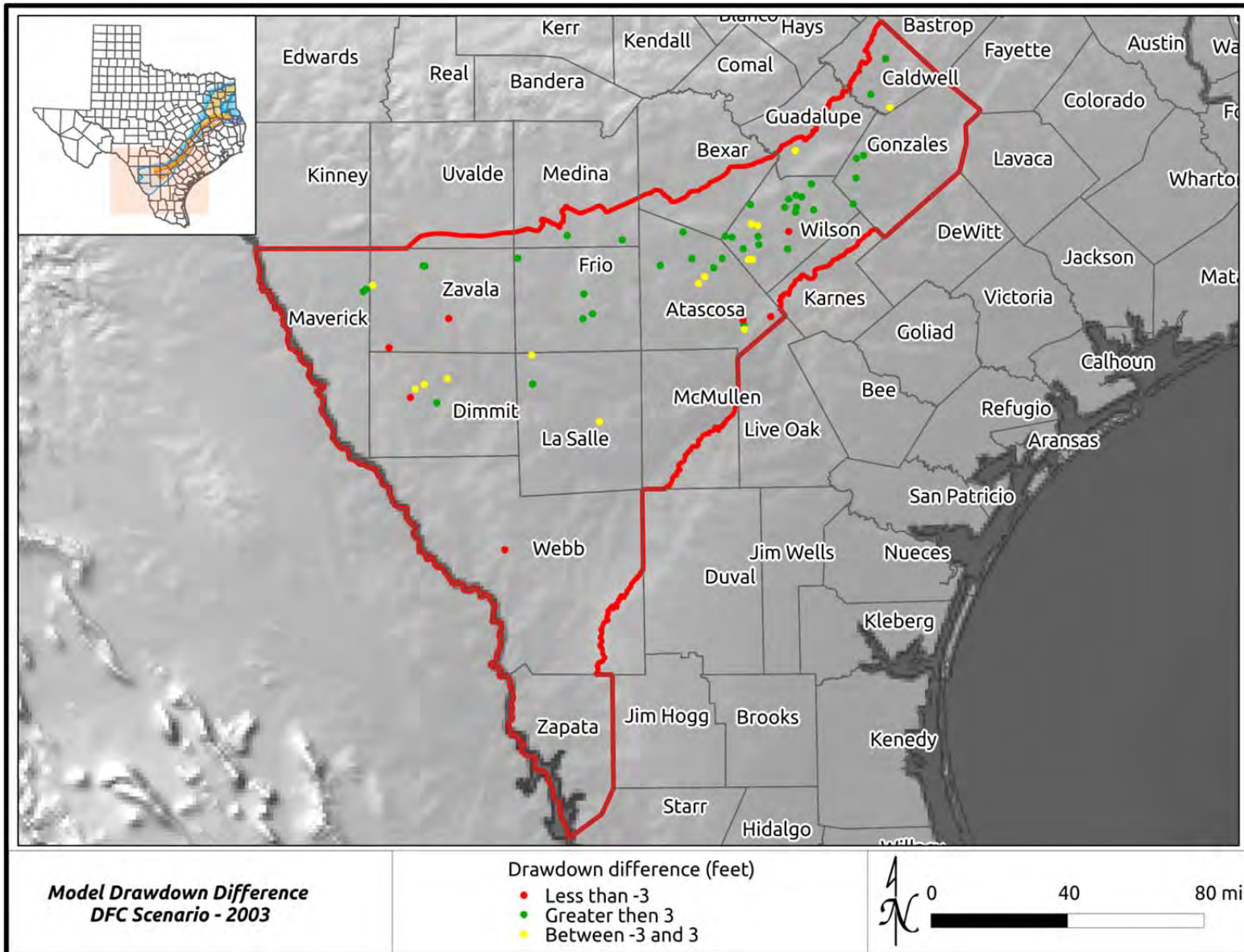

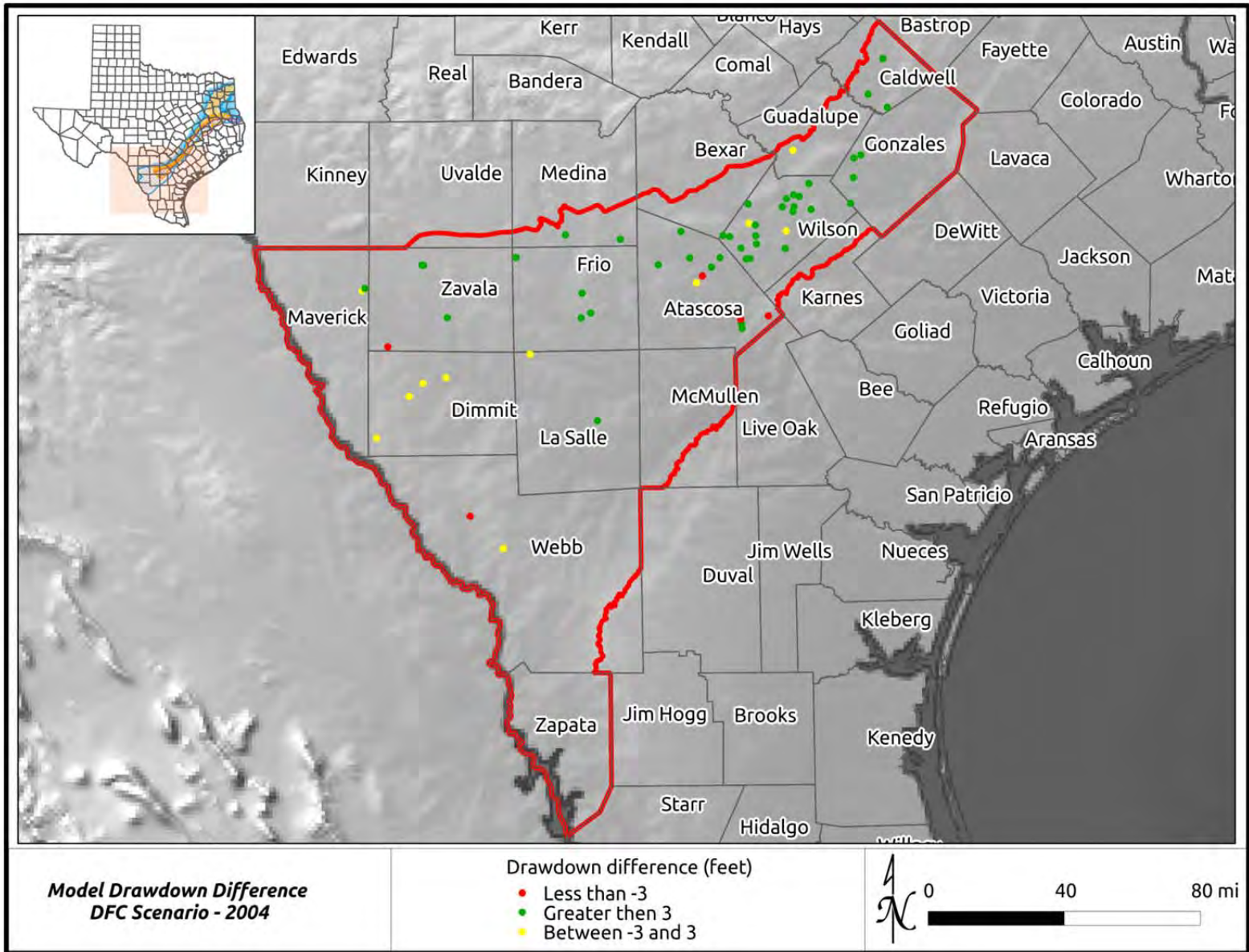

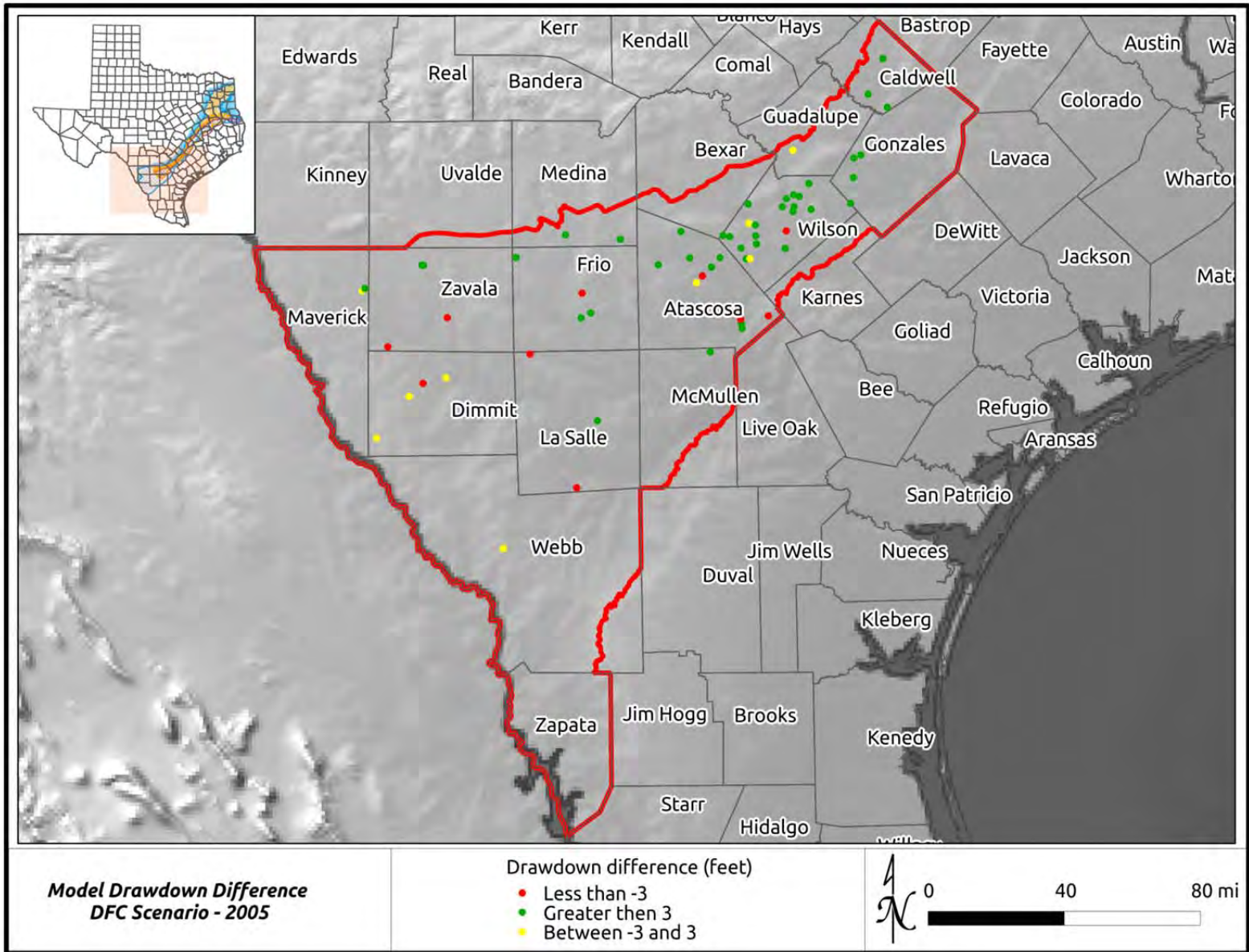

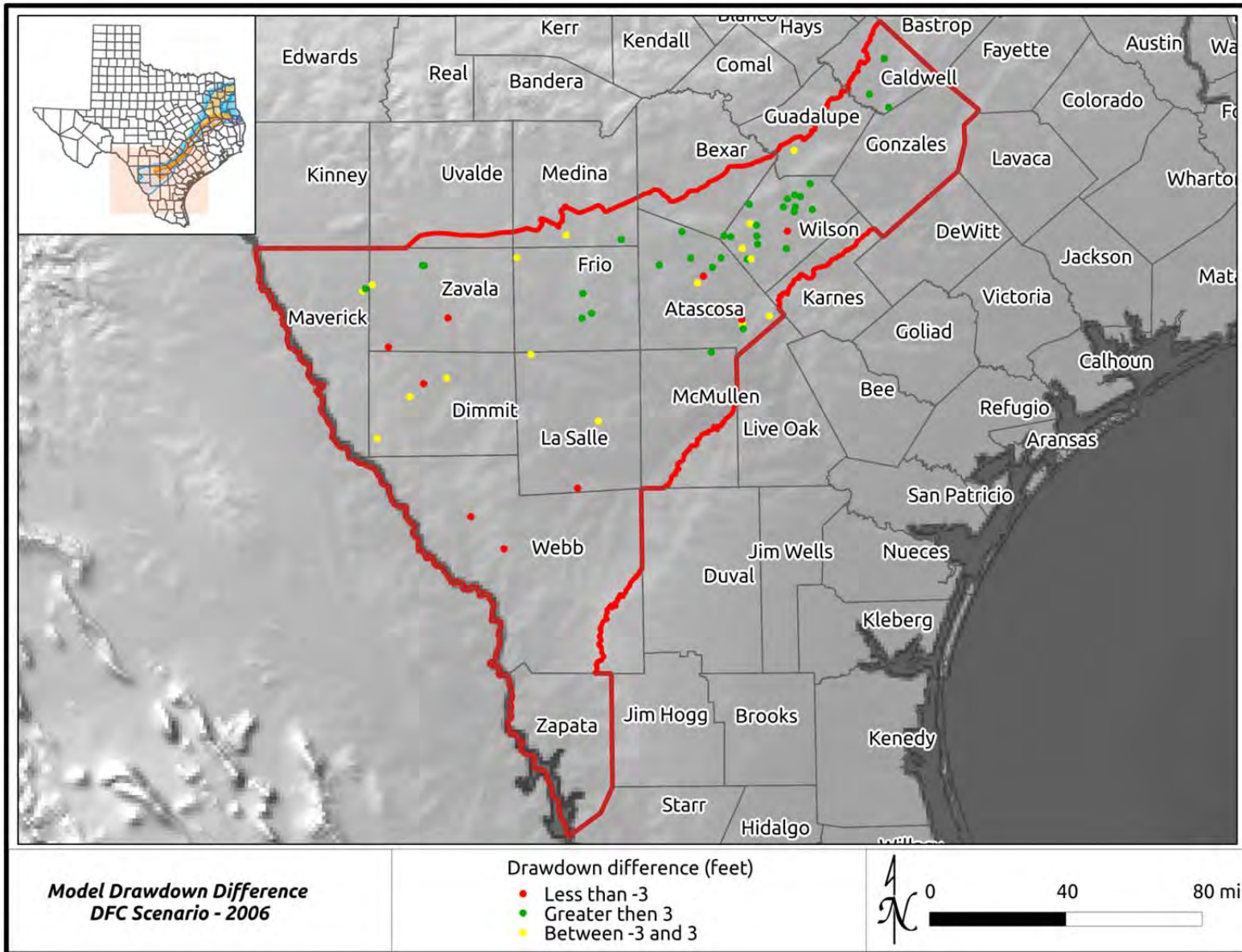

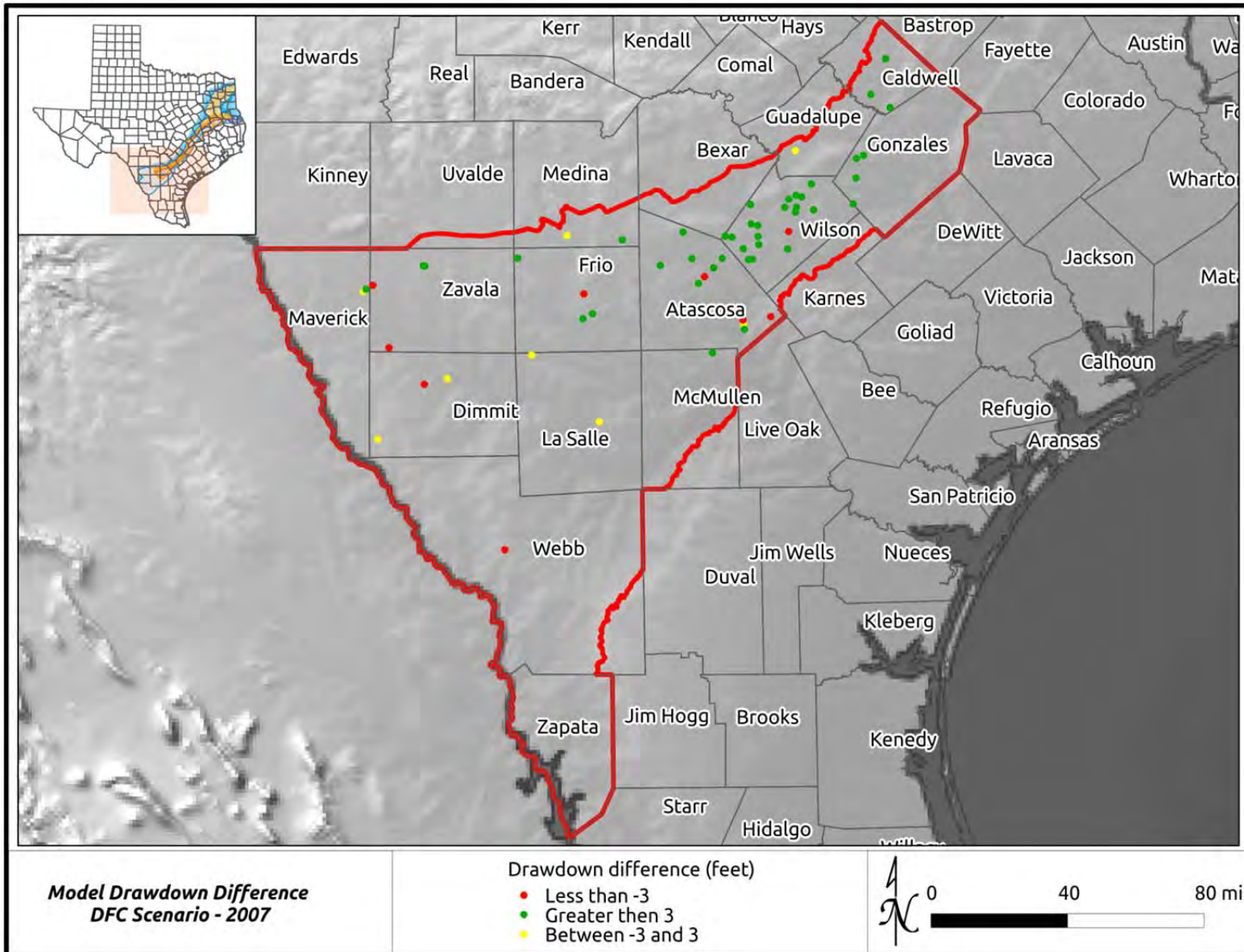

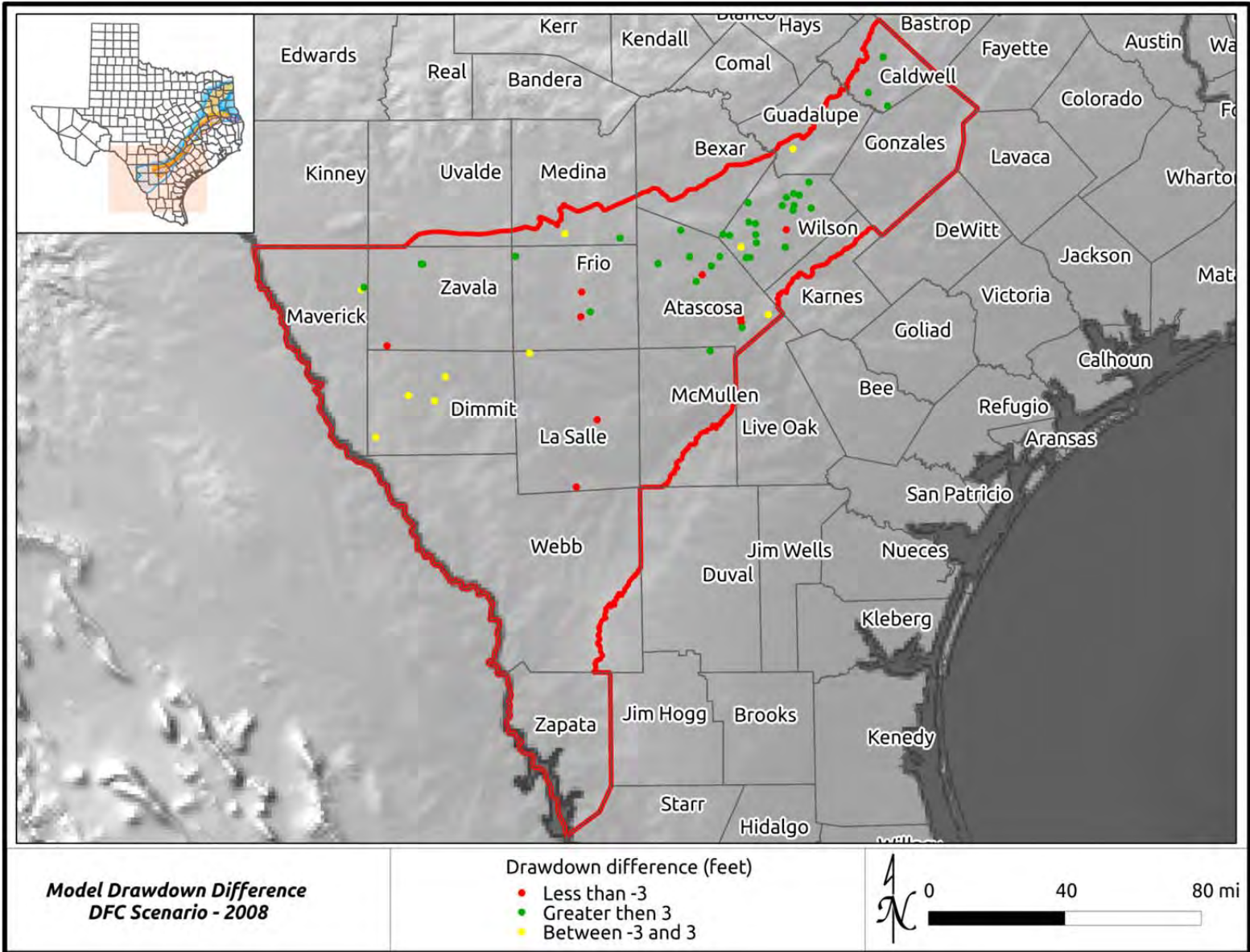

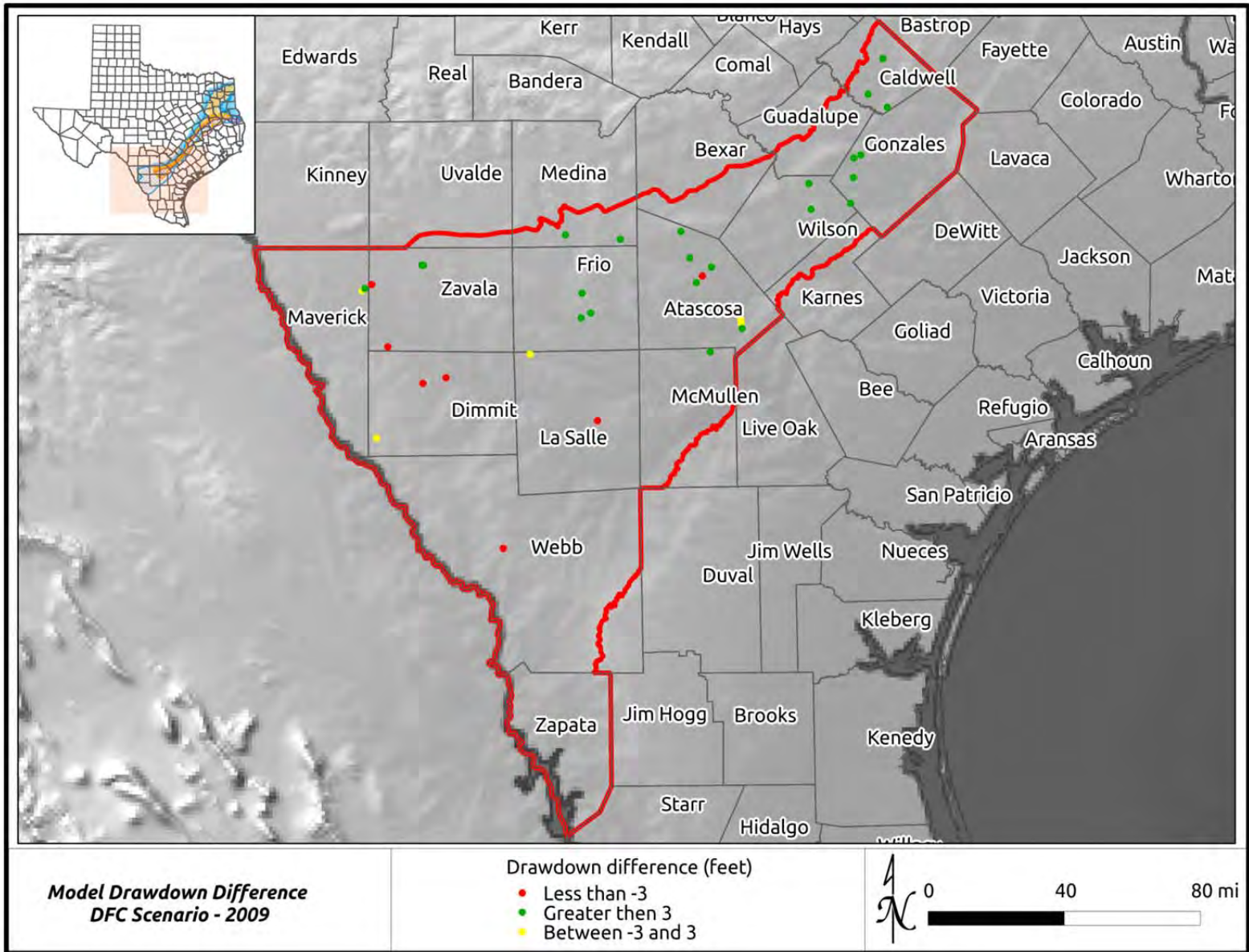

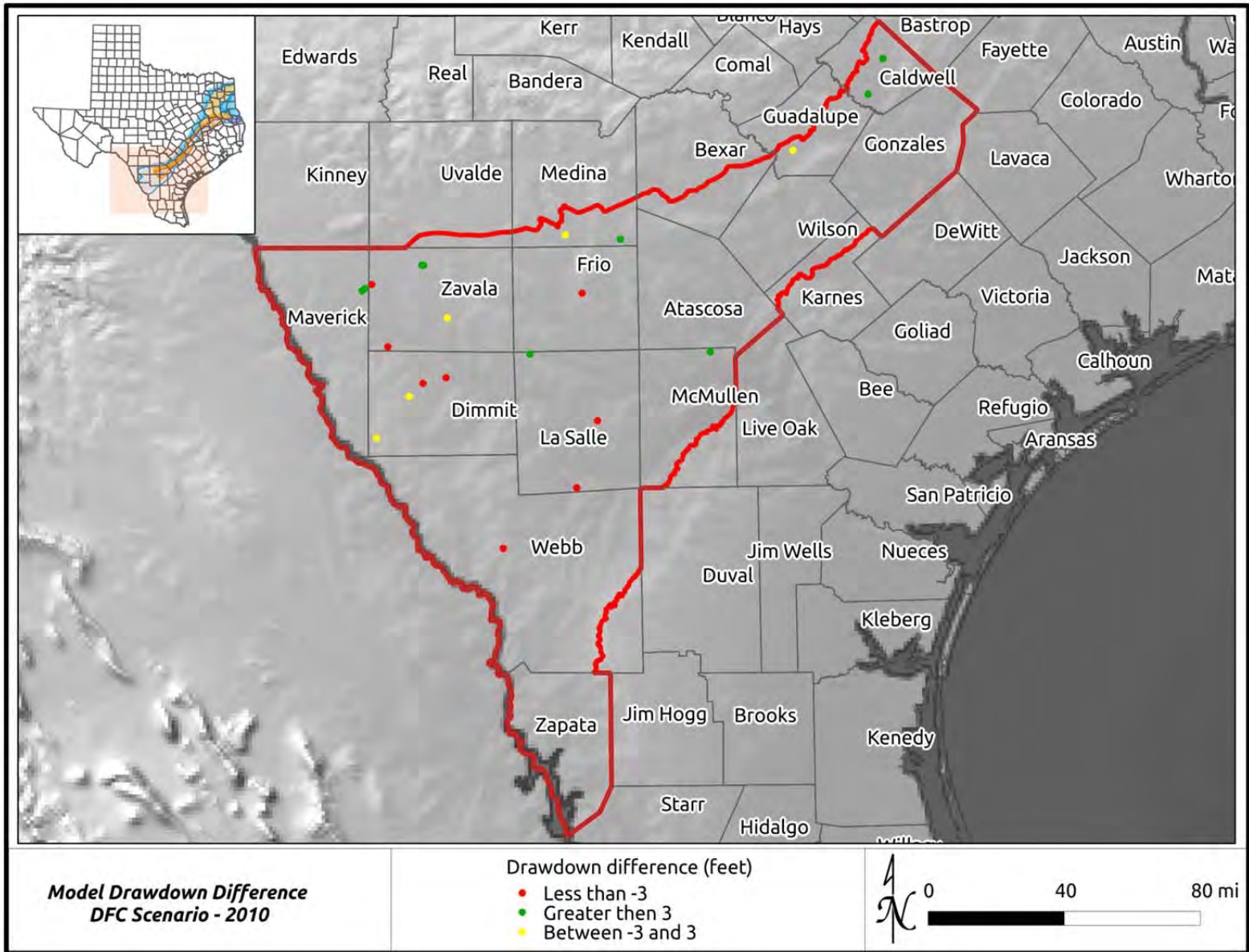

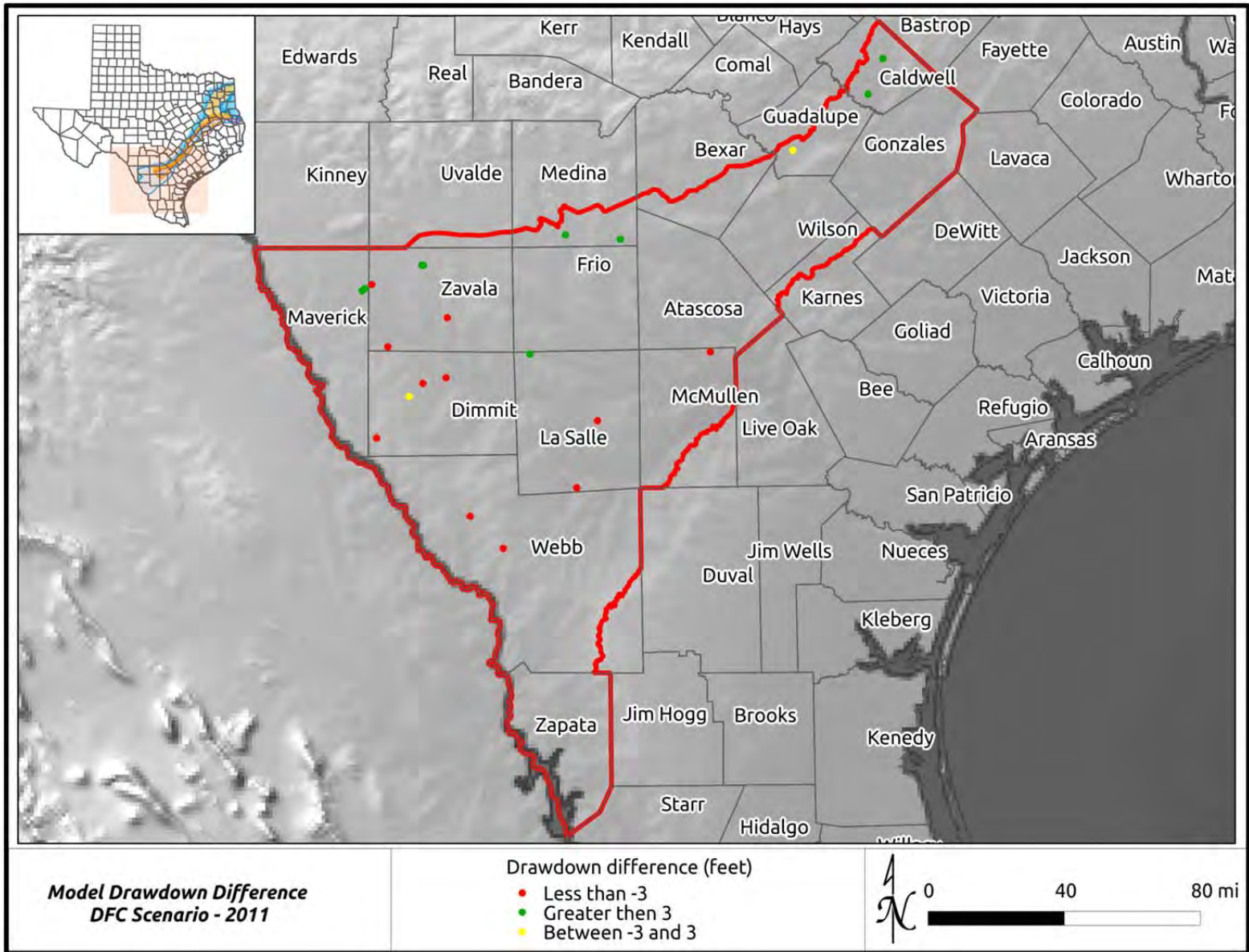

Appendix 2 – Atascosa County

Location Map of Hydrograph Wells

Hydrographs

Note that pumping data are expressed in three zones:

- Pump 1 = pumping from cell where well is located
- Pump 2 = pumping in cells adjacent to Zone 1
- Pump 3 = pumping in cells adjacent to Zone 2

Screen Bottom and Screen Top = Elevation of Well Completion Interval

Land Surface = Elevation of Land Surface at Well

Groundwater Elevations

- Measured = Actual data from TWDB database
- Calibrated Model = Results for cell defined by well from calibrated model
- DFC = Results for cell defined by well from Scenario 4 of GAM Run 09-034

Drawdown Comparison Maps for 2001 and 2006

Summary of Drawdown Comparisons

Table analogous to Table 5 in text summarizing annual average drawdown (actual and DFC)

Histogram of Differences between DFC Drawdown and Actual Drawdown for All Years

Figure analogous to Figure 23 in text showing differences between actual drawdown and DFC conditions

Hydrograph of Actual Drawdown and DFC Drawdown

Figure analogous to Figure 26 in text showing time history of drawdown (actual and DFC) from 2000 to 2011

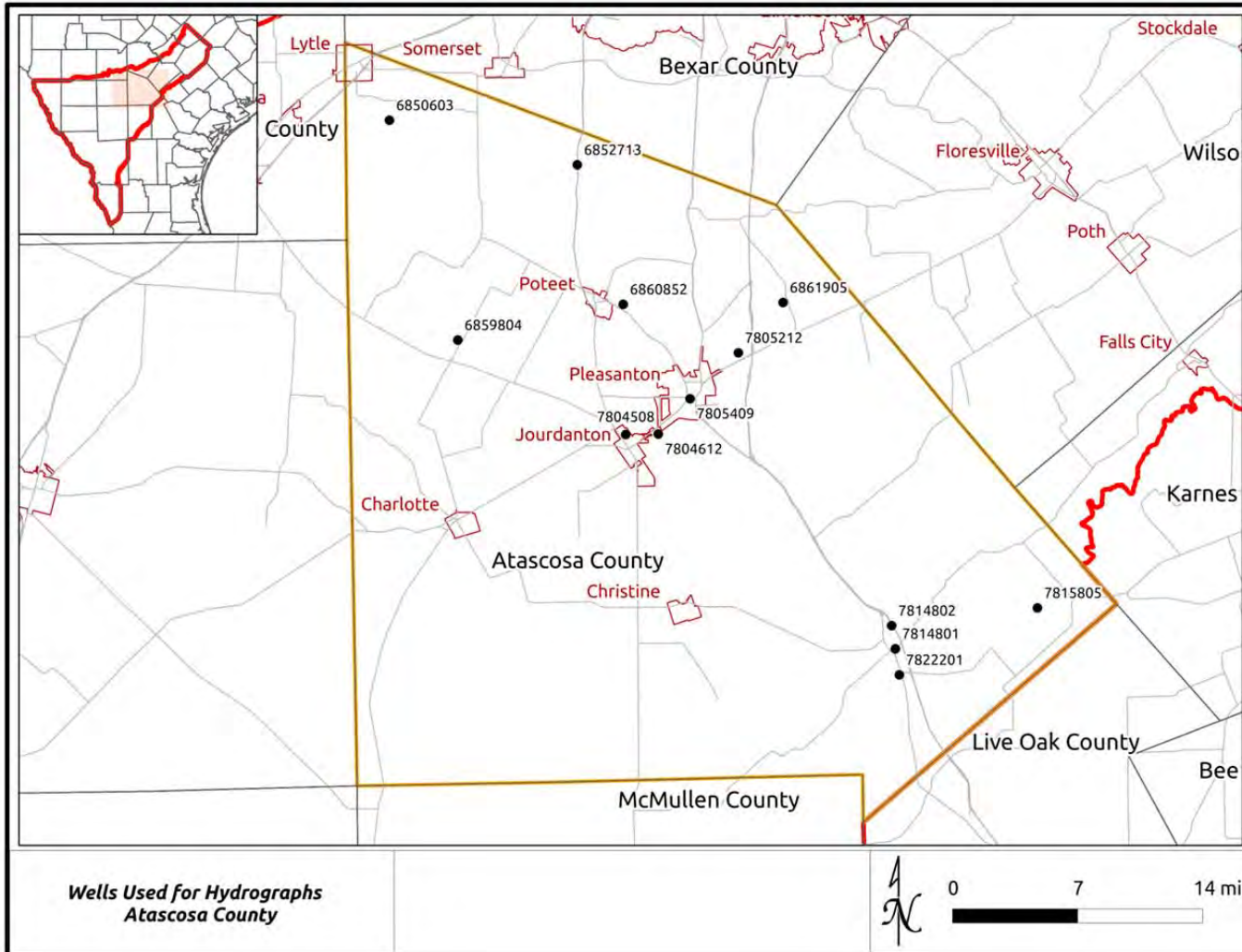

Location Map of Wells with Hydrographs – Atascosa County

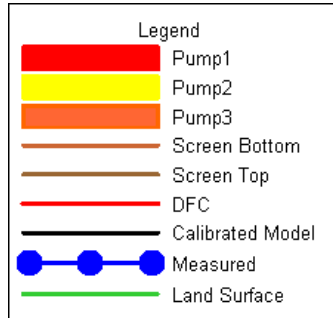

Well 6850603
Atascosa County - Layer 7

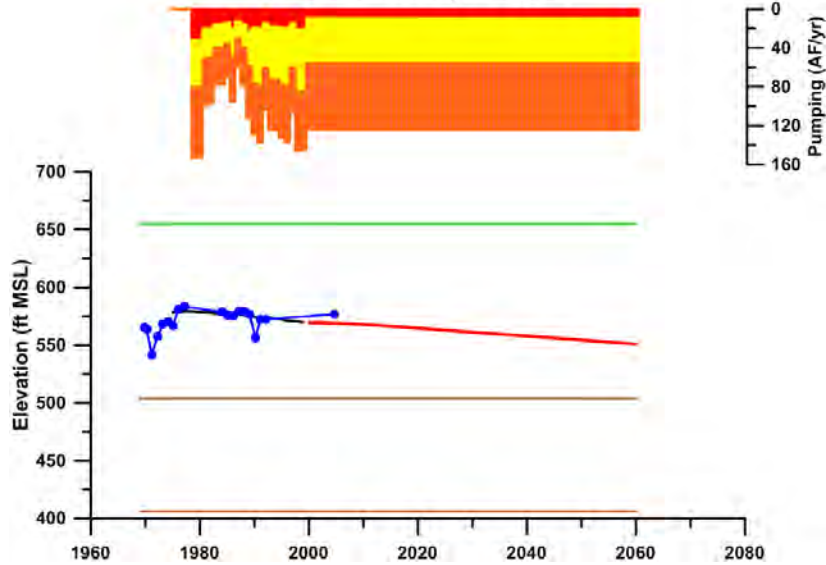

Well 6852713
Atascosa County - Layer 5

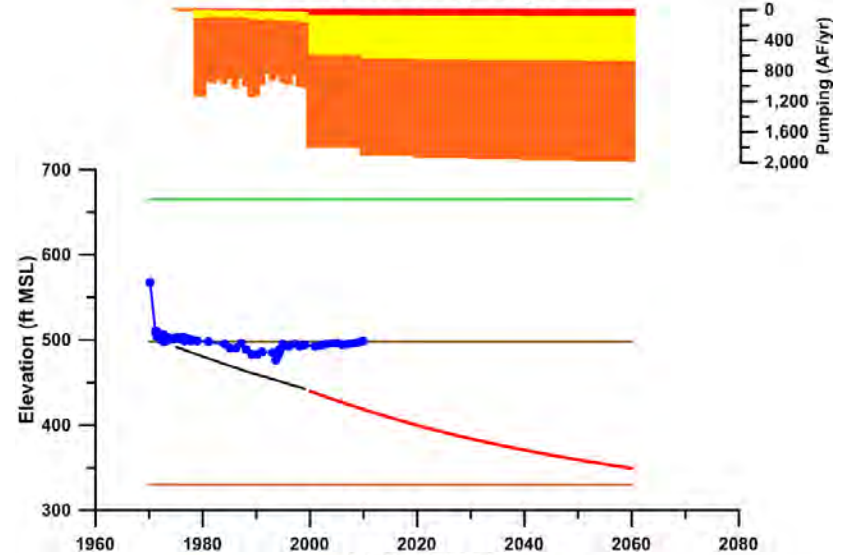

Well 6859804
Atascosa County - Layer 5

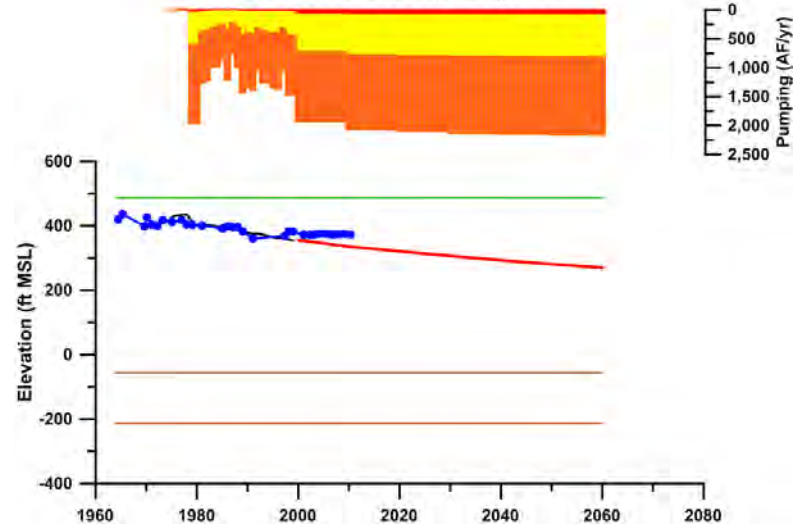

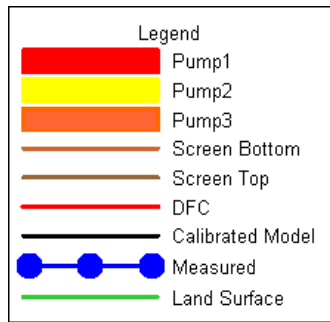

Well 6860852
Atascosa County - Layer 5

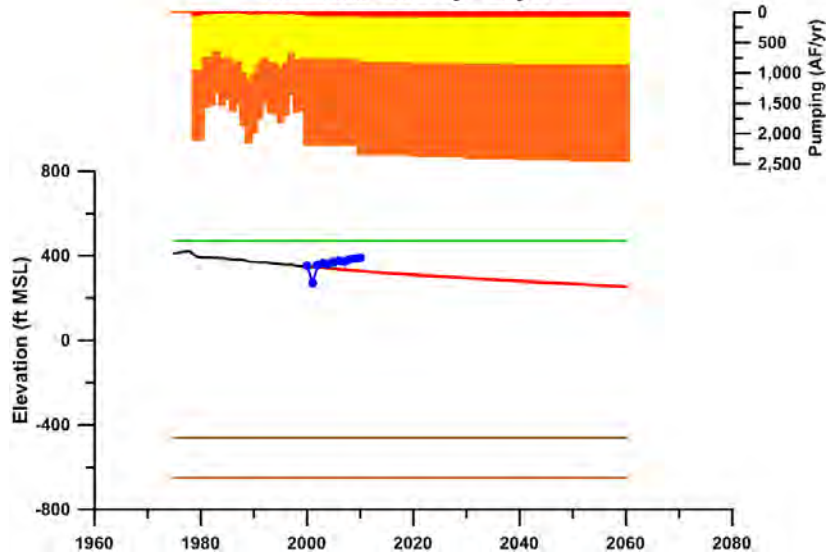

Well 6861905
Atascosa County - Layer 5

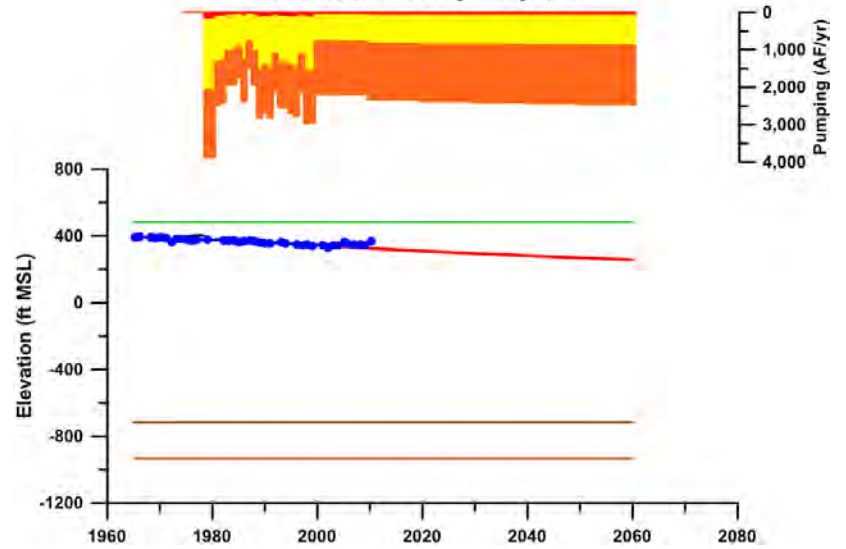

Well 7804508
Atascosa County - Layer 5

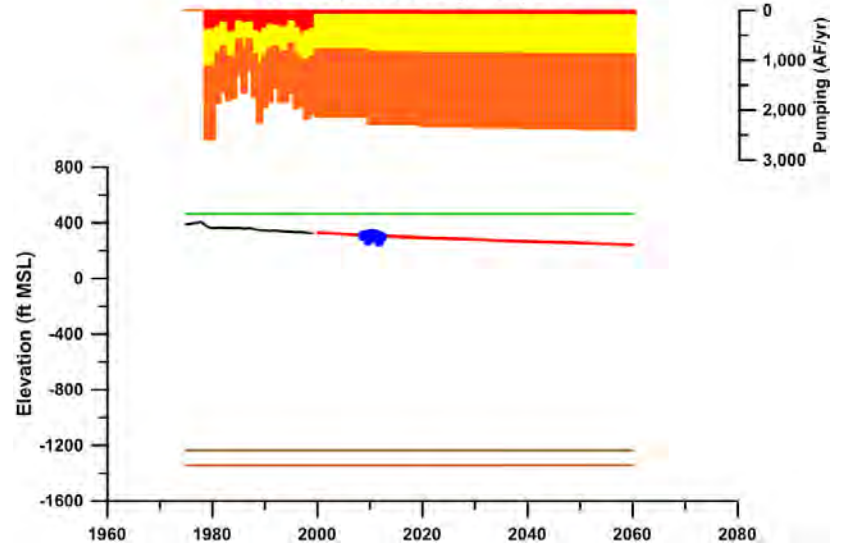

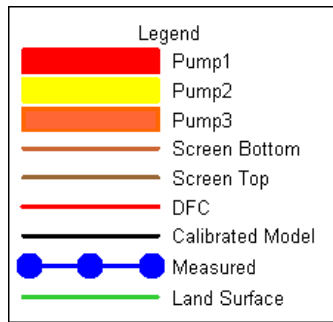

Well 7804612
Atascosa County - Layer 5

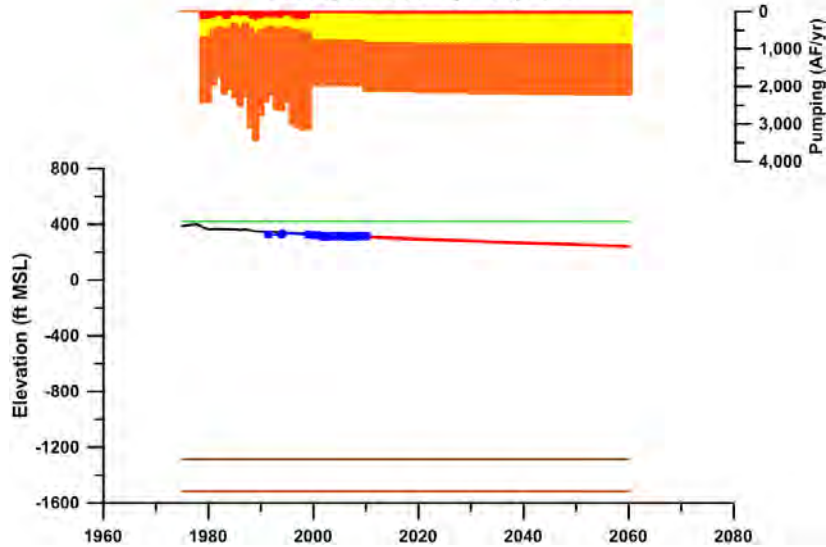

Well 7805212
Atascosa County - Layer 5

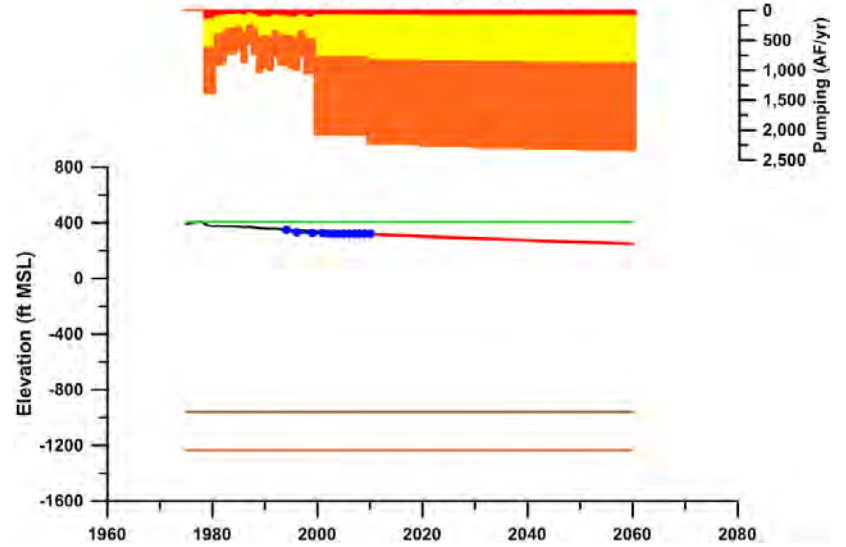

Well 7805409
Atascosa County - Layer 3

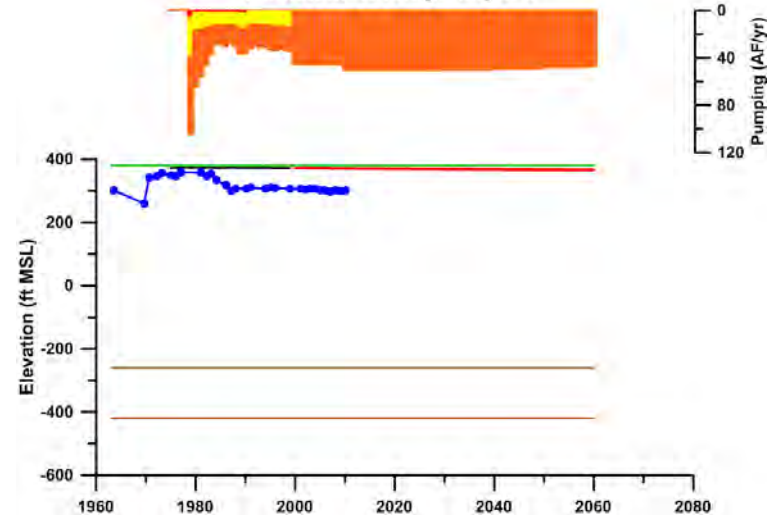

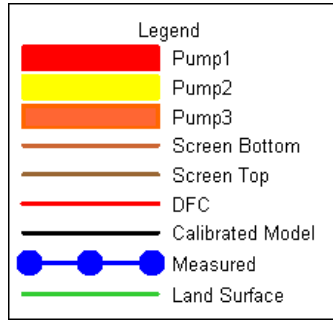

Well 7814801
Atascosa County - Layer 5

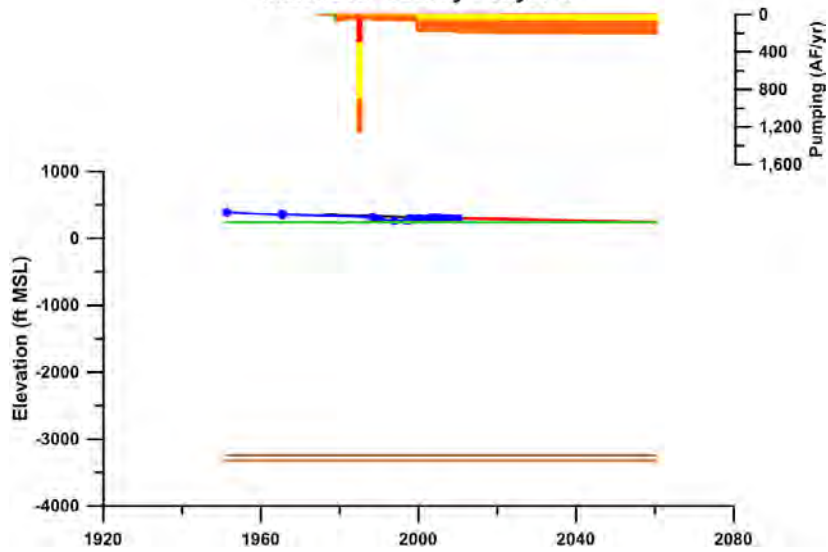

Well 7814802
Atascosa County - Layer 5

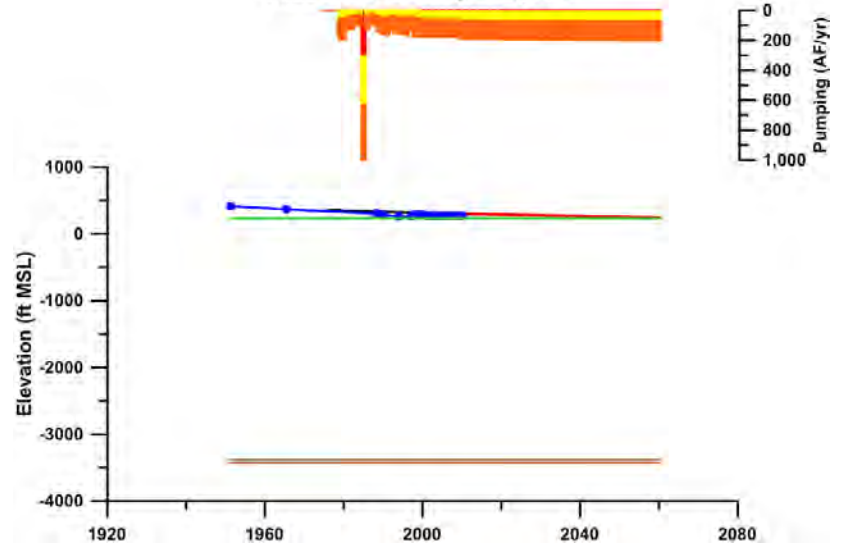

Well 7815805
Atascosa County - Layer 5

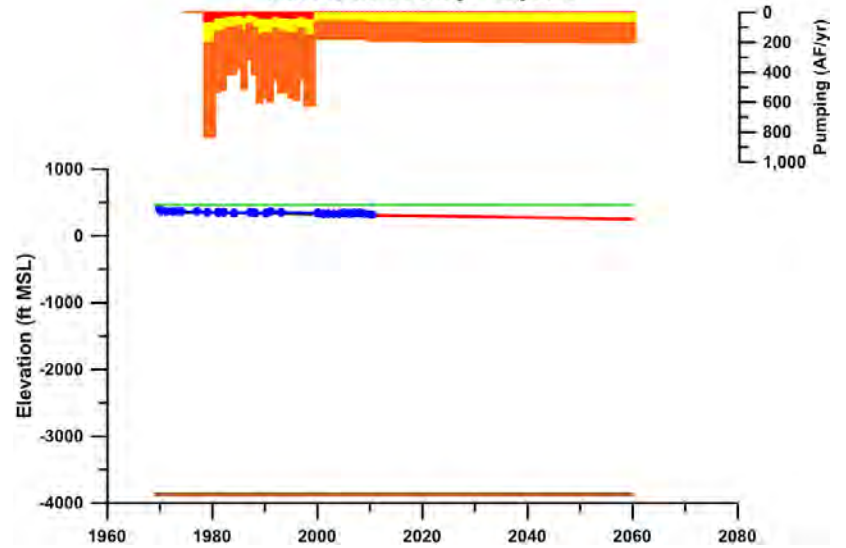

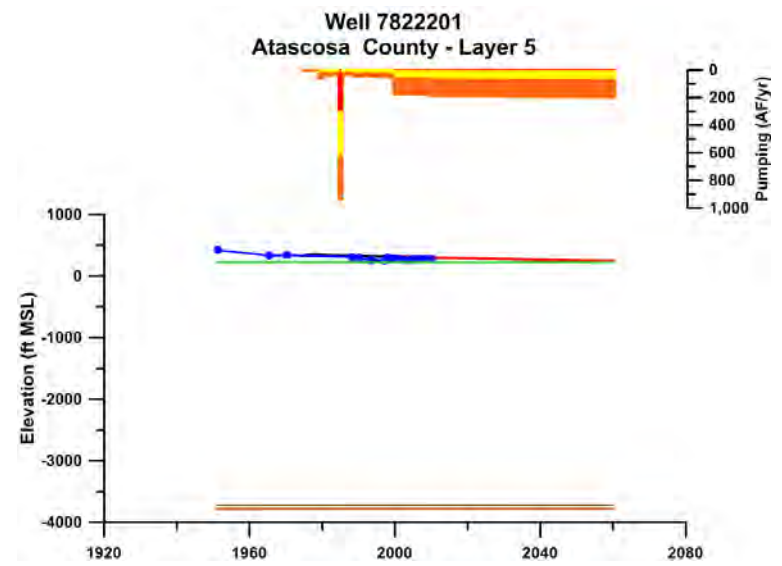
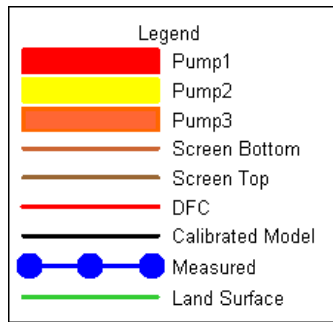

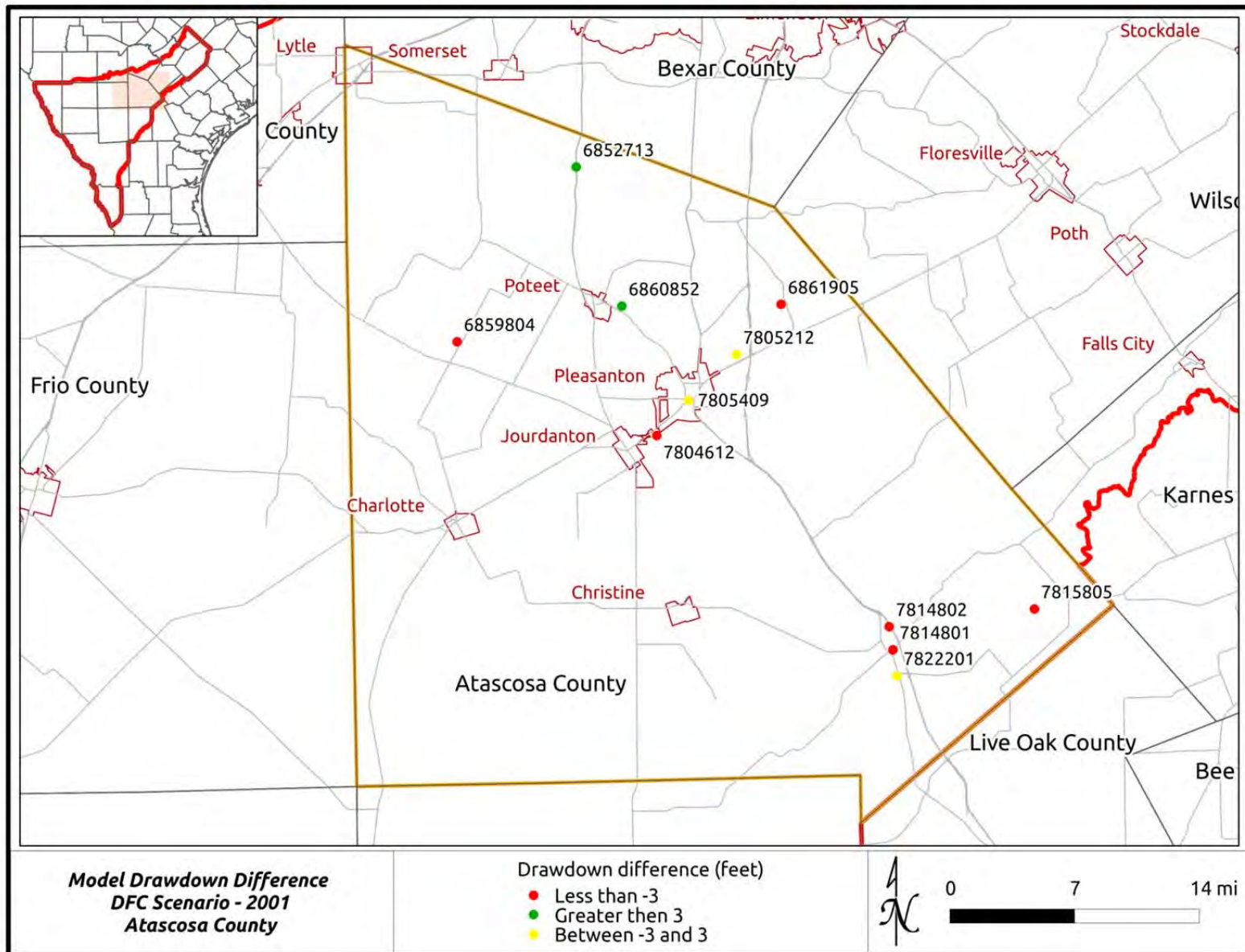

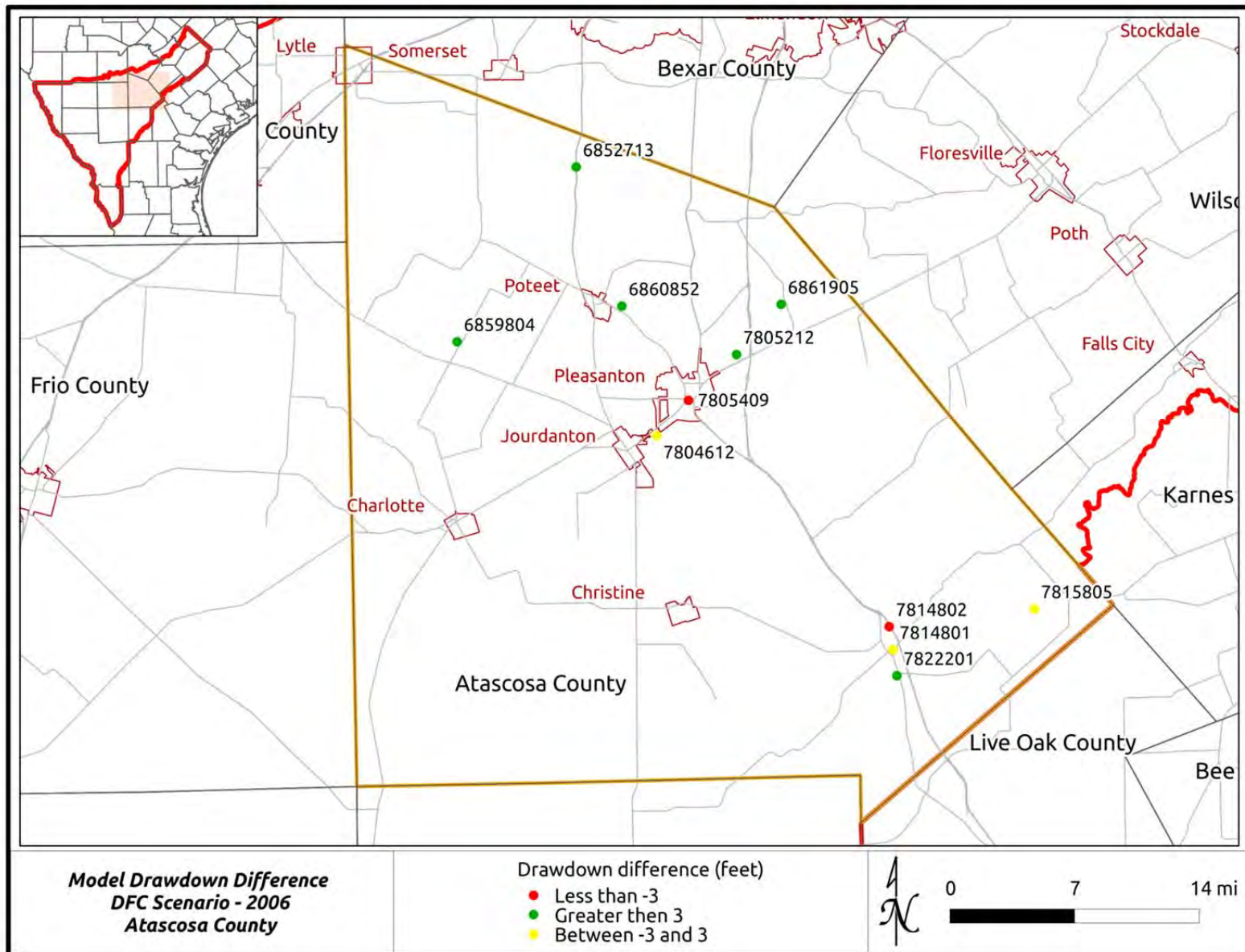

Summary of Drawdown Comparisons - Atascosa County

<i>Column 1</i>	<i>Column 2</i>	<i>Column 3</i>	<i>Column 4</i>	<i>Column 5</i>	<i>Column 6</i>	<i>Column 7</i>
Year	Precipitation (% Avg)	County-Wide Average DFC	Number of Actual Drawdown Data Points	Average Actual Drawdown for Wells with Data	Average DFC for Wells with Data	Column 6 minus Column 5
2000	90	1.25	8	5.28	0.31	-4.97
2001	101	3.01	11	7.52	1.66	-5.87
2002	113	4.81	11	1.73	3.15	1.42
2003	96	6.58	11	1.88	4.78	2.89
2004	132	8.30	11	-1.46	6.45	7.91
2005	75	9.97	11	1.43	8.14	6.70
2006	86	11.59	11	2.90	9.81	6.91
2007	142	13.15	11	0.92	11.46	10.54
2008	74	14.67	11	1.91	13.09	11.18
2009	76	16.15	8	-0.63	14.76	15.39
2010	132	17.53				
2011	45	18.75				

Atascosa County - All Years

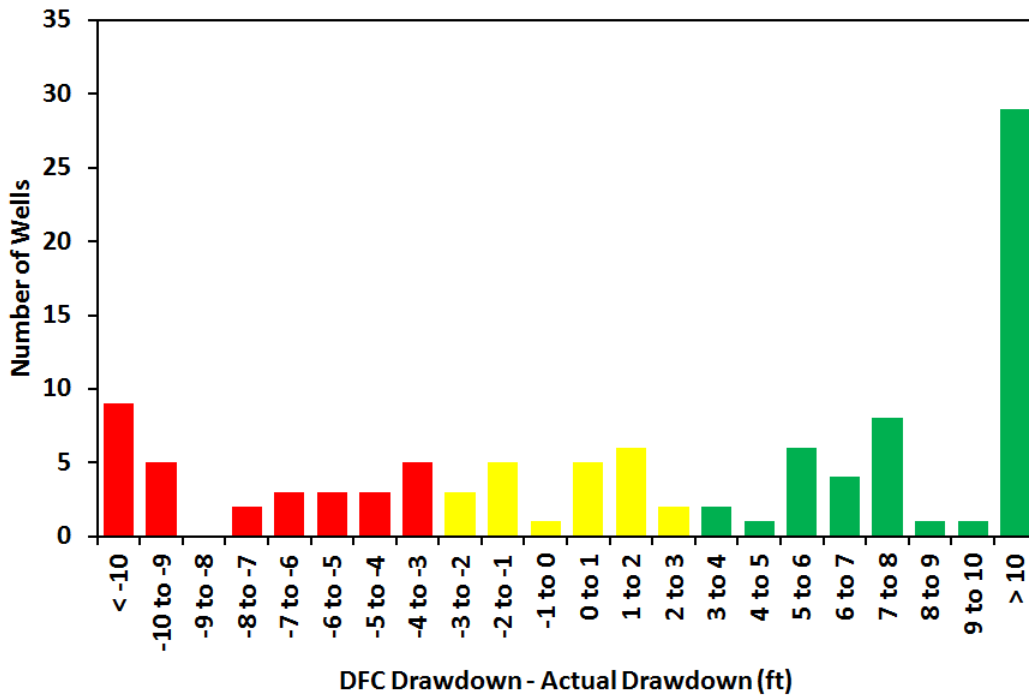

Atascosa County

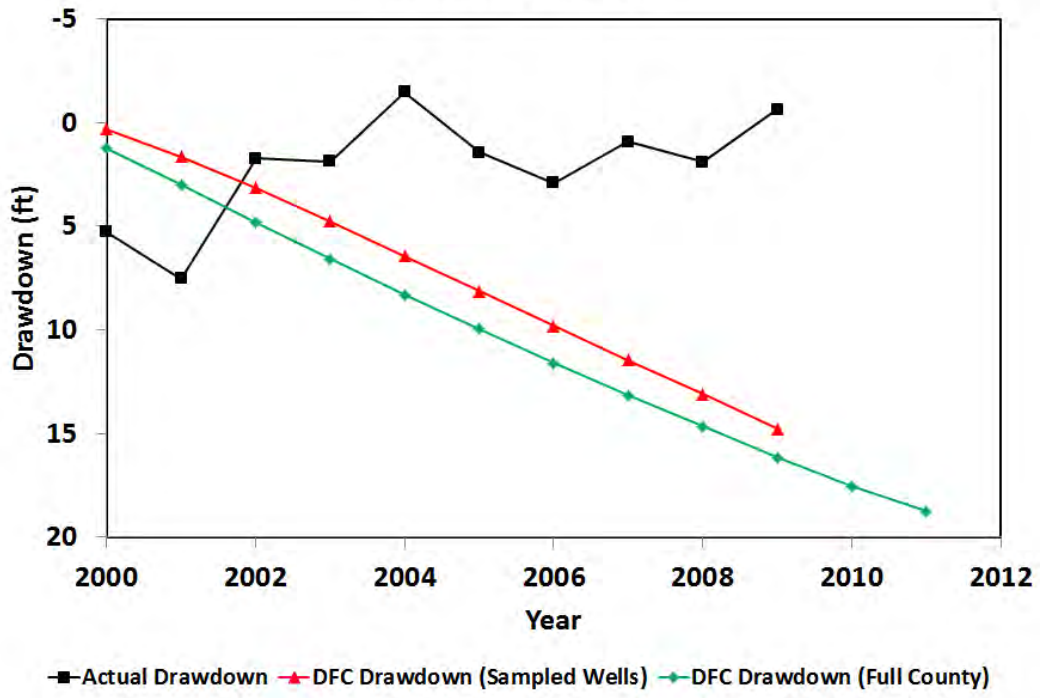

Appendix 3 – Bexar County

Location Map of Hydrograph Wells

Hydrographs

Note that pumping data are expressed in three zones:

- Pump 1 = pumping from cell where well is located
- Pump 2 = pumping in cells adjacent to Zone 1
- Pump 3 = pumping in cells adjacent to Zone 2

Screen Bottom and Screen Top = Elevation of Well Completion Interval

Land Surface = Elevation of Land Surface at Well

Groundwater Elevations

- Measured = Actual data from TWDB database
- Calibrated Model = Results for cell defined by well from calibrated model
- DFC = Results for cell defined by well from Scenario 4 of GAM Run 09-034

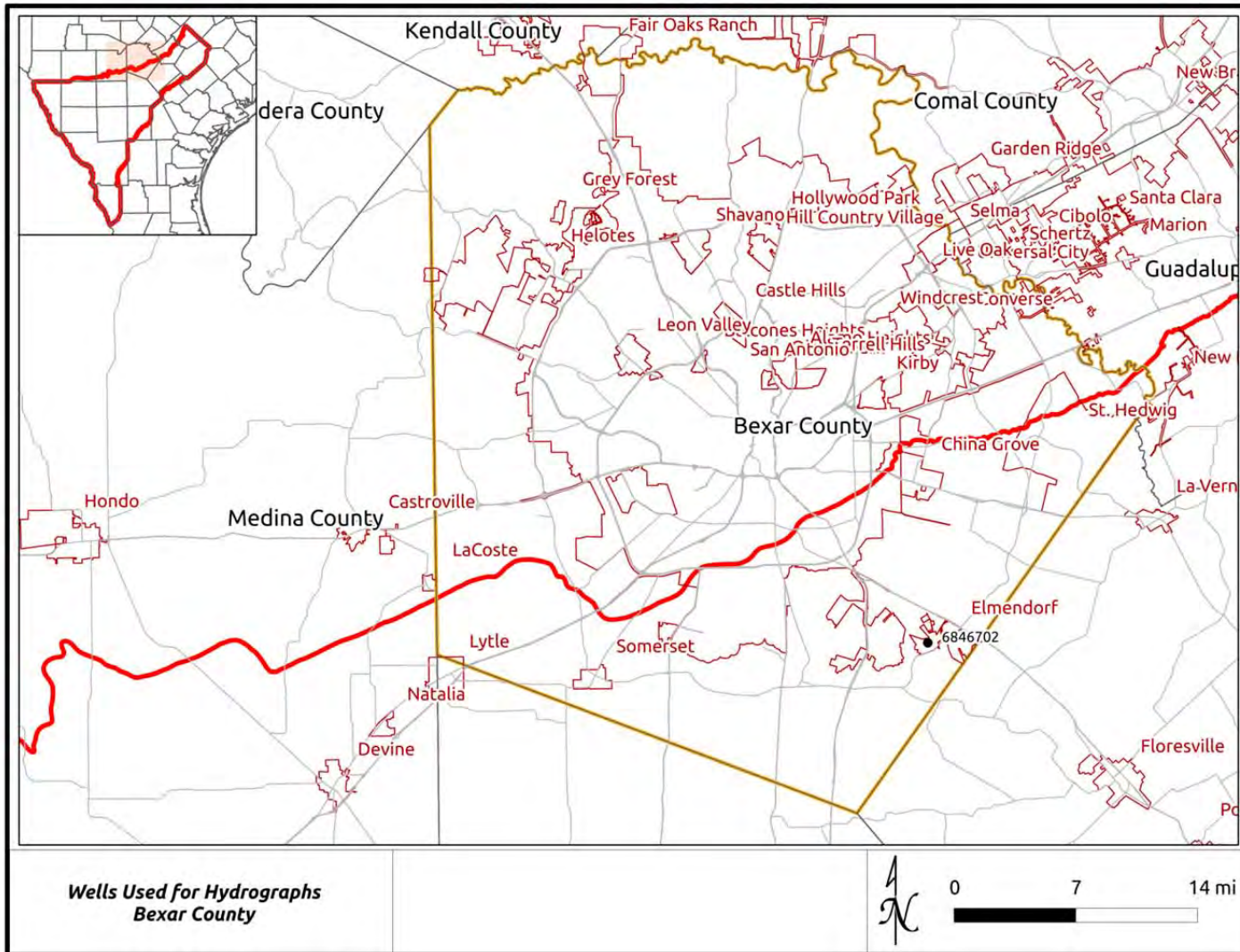

Location Map of Wells with Hydrographs – Bexar County

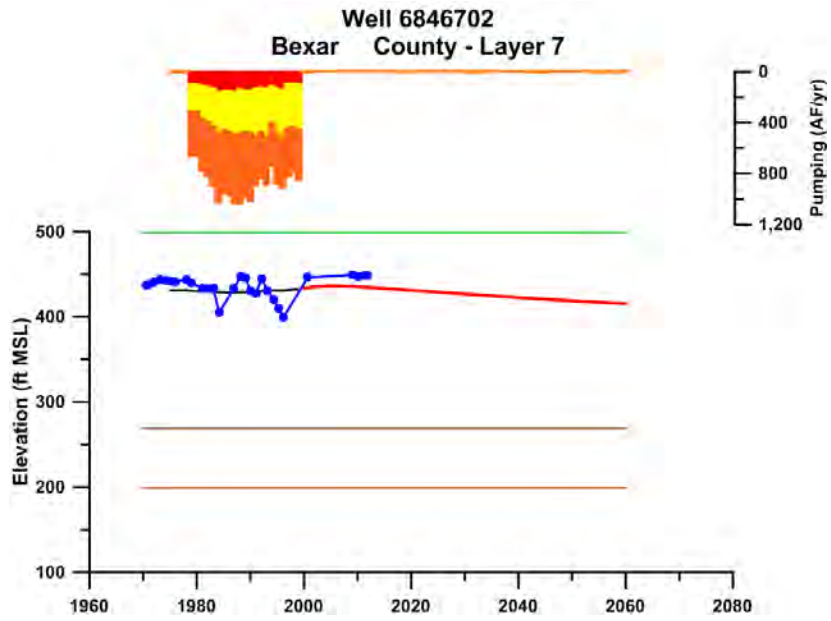
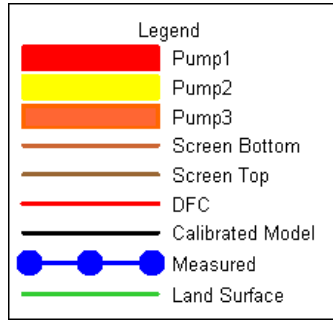

Appendix 4 – Caldwell County

Location Map of Hydrograph Wells

Hydrographs

Note that pumping data are expressed in three zones:

- Pump 1 = pumping from cell where well is located
- Pump 2 = pumping in cells adjacent to Zone 1
- Pump 3 = pumping in cells adjacent to Zone 2

Screen Bottom and Screen Top = Elevation of Well Completion Interval

Land Surface = Elevation of Land Surface at Well

Groundwater Elevations

- Measured = Actual data from TWDB database
- Calibrated Model = Results for cell defined by well from calibrated model
- DFC = Results for cell defined by well from Scenario 4 of GAM Run 09-034

Drawdown Comparison Maps for 2001, 2006 and 2011

Summary of Drawdown Comparisons

Table analogous to Table 5 in text summarizing annual average drawdown (actual and DFC)

Histogram of Differences between DFC Drawdown and Actual Drawdown for All Years

Figure analogous to Figure 23 in text showing differences between actual drawdown and DFC conditions

Hydrograph of Actual Drawdown and DFC Drawdown

Figure analogous to Figure 26 in text showing time history of drawdown (actual and DFC) from 2000 to 2011

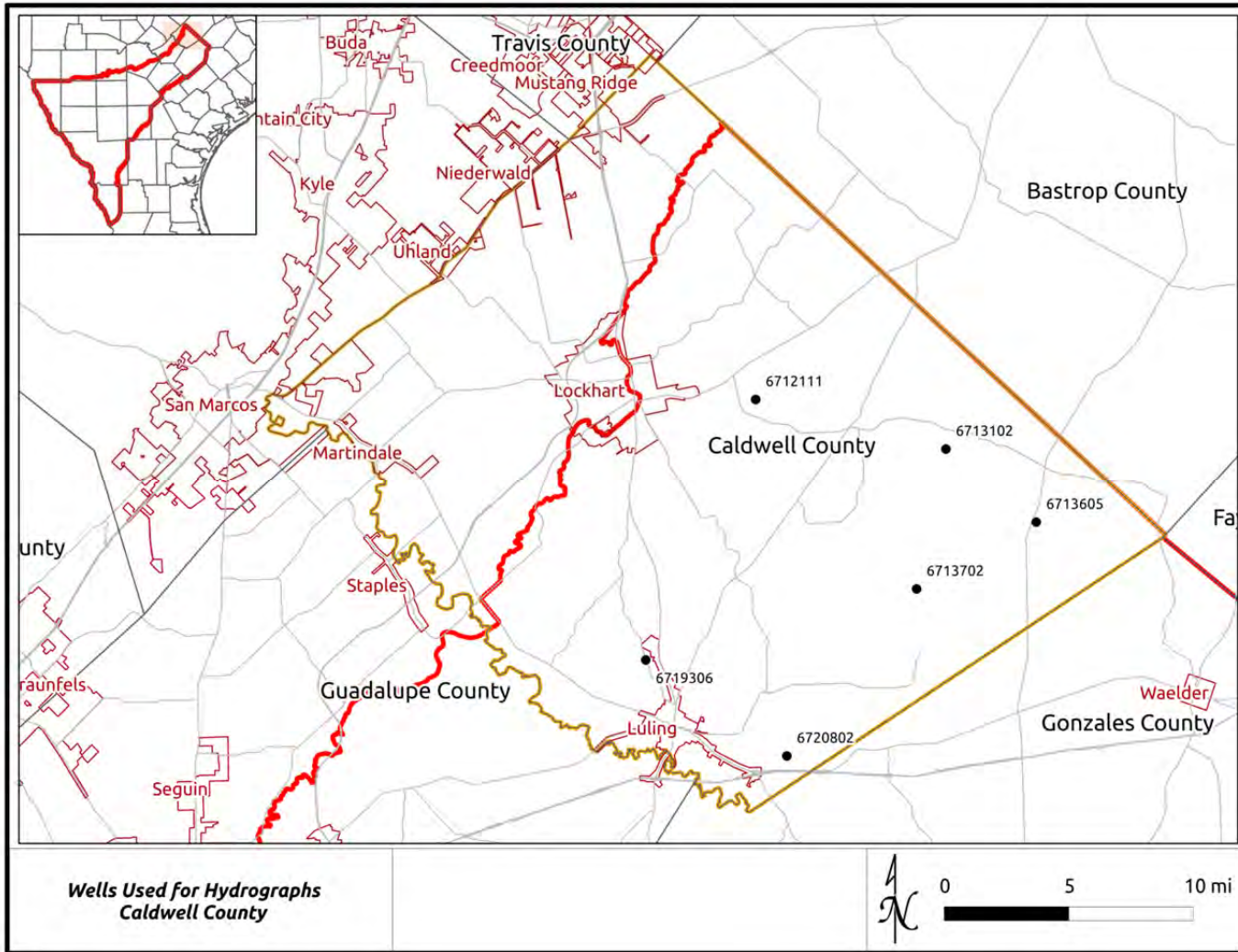

Location Map of Wells with Hydrographs – Caldwell County

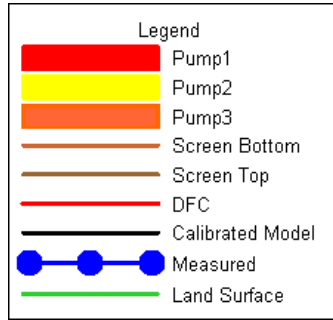

**Well 6712111
Caldwell County - Layer 8**

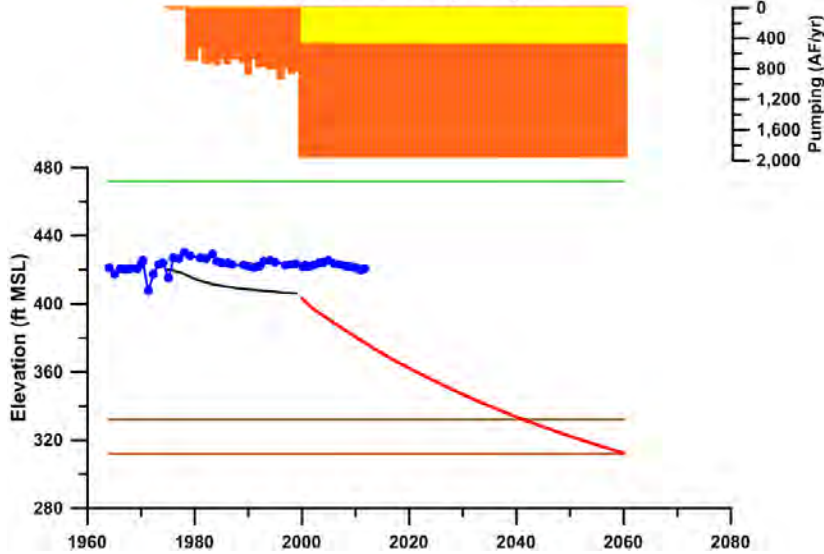

**Well 6713102
Caldwell County - Layer 7**

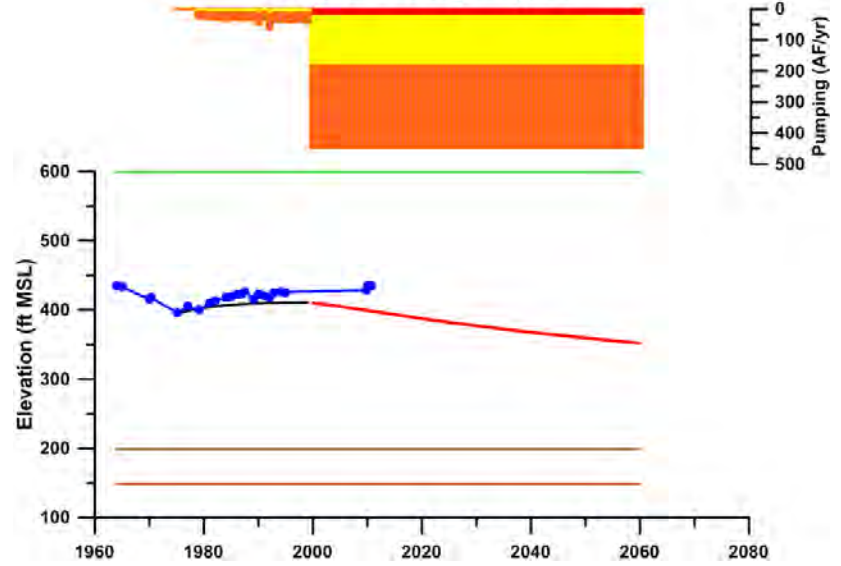

**Well 6713605
Caldwell County - Layer 5**

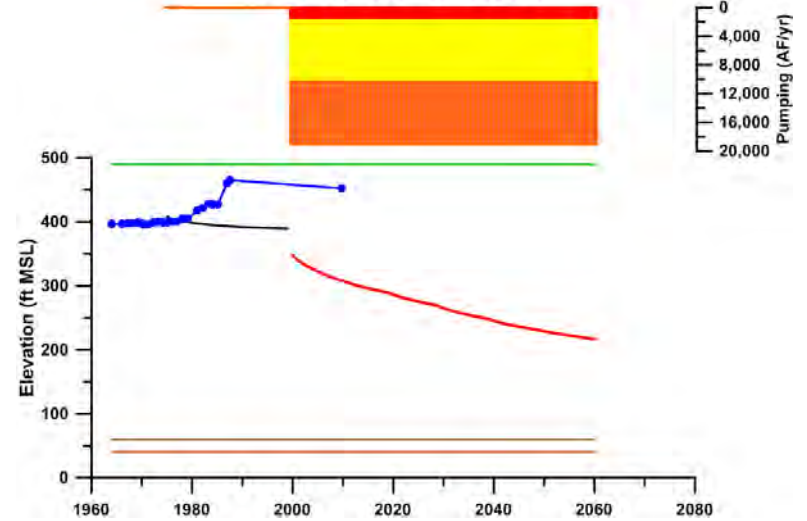

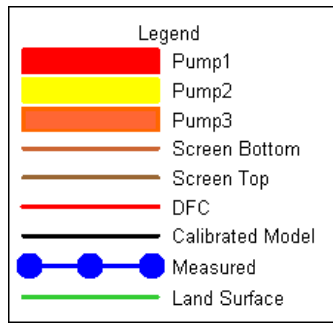

**Well 6713702
Caldwell County - Layer 5**

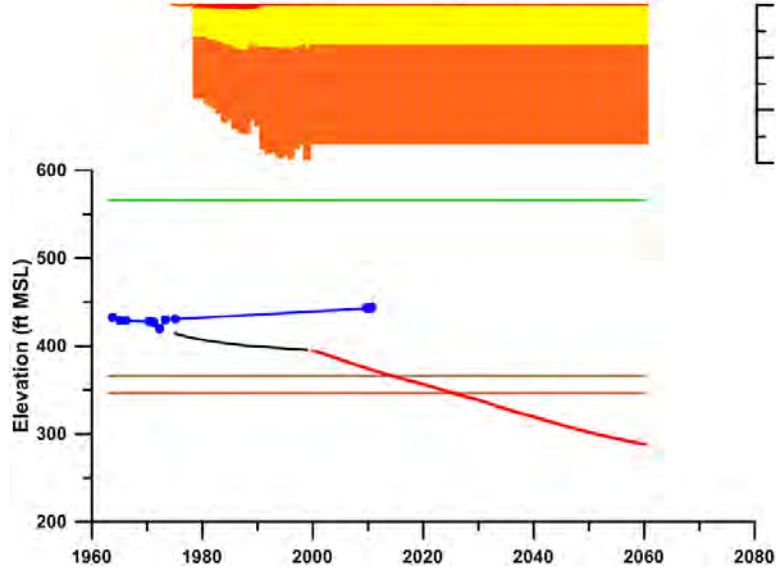

**Well 6719306
Caldwell County - Layer 8**

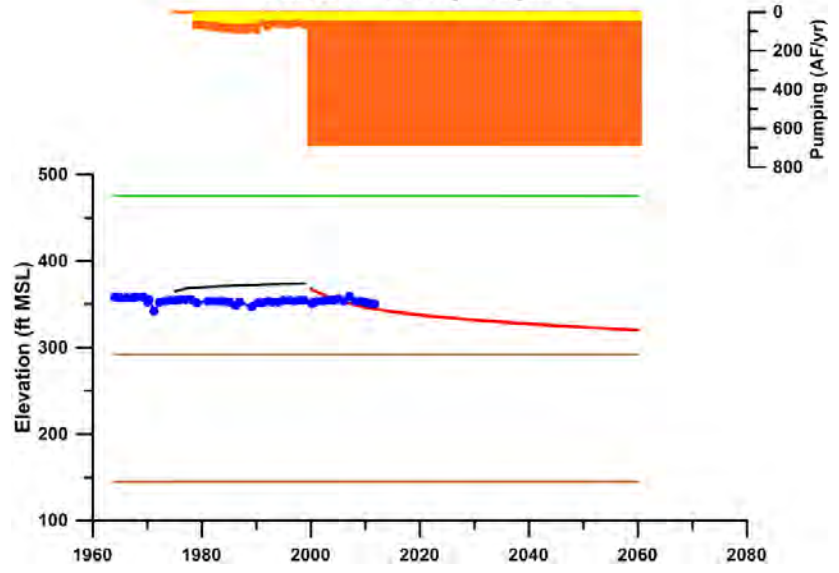

**Well 6720802
Caldwell County - Layer 7**

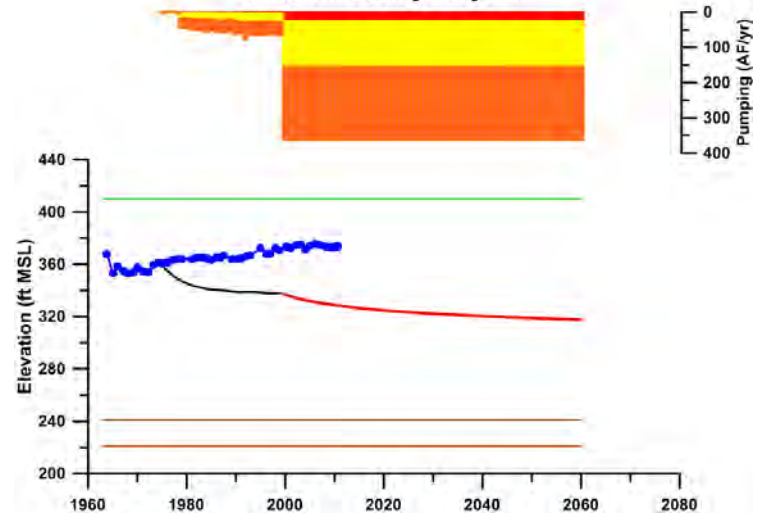

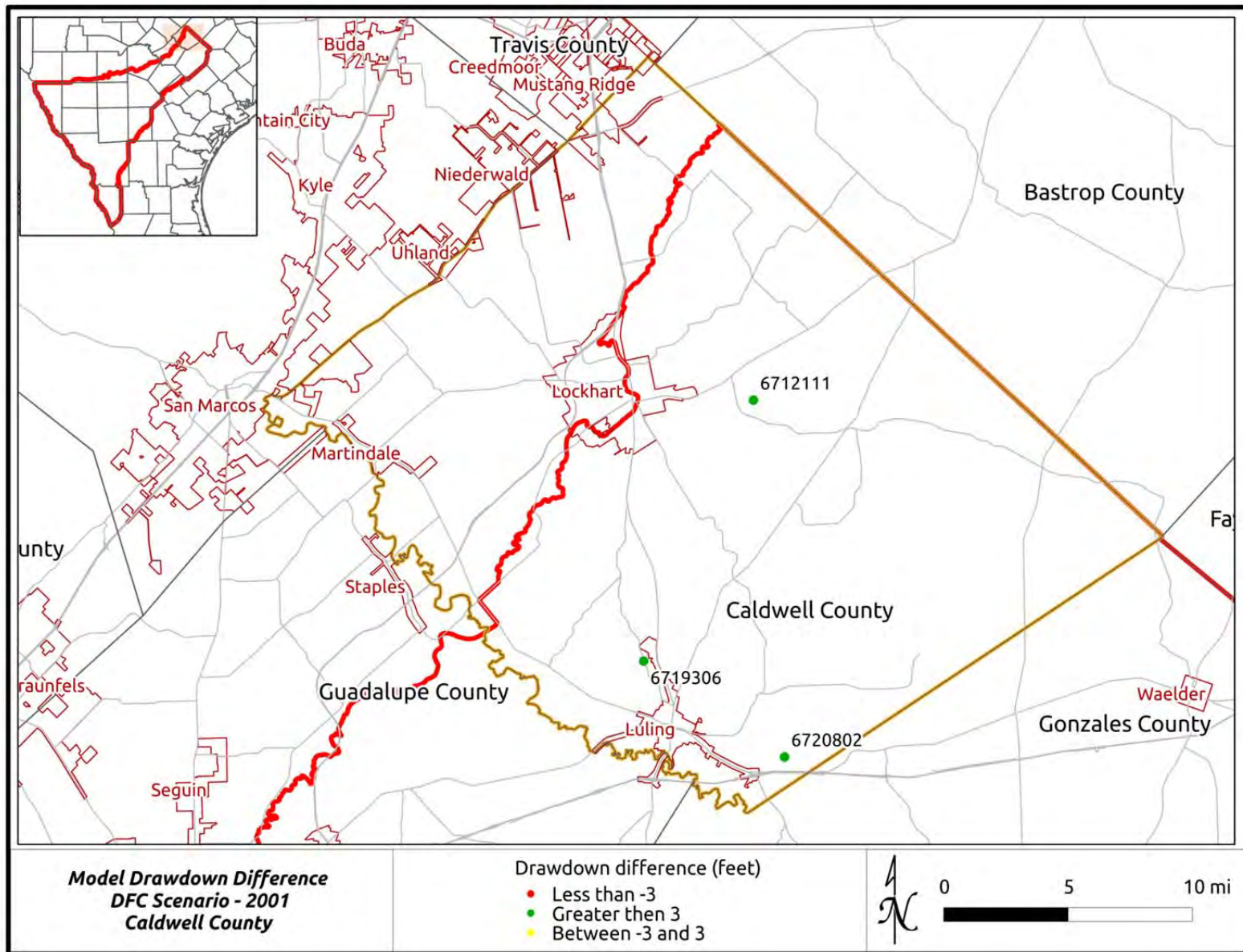

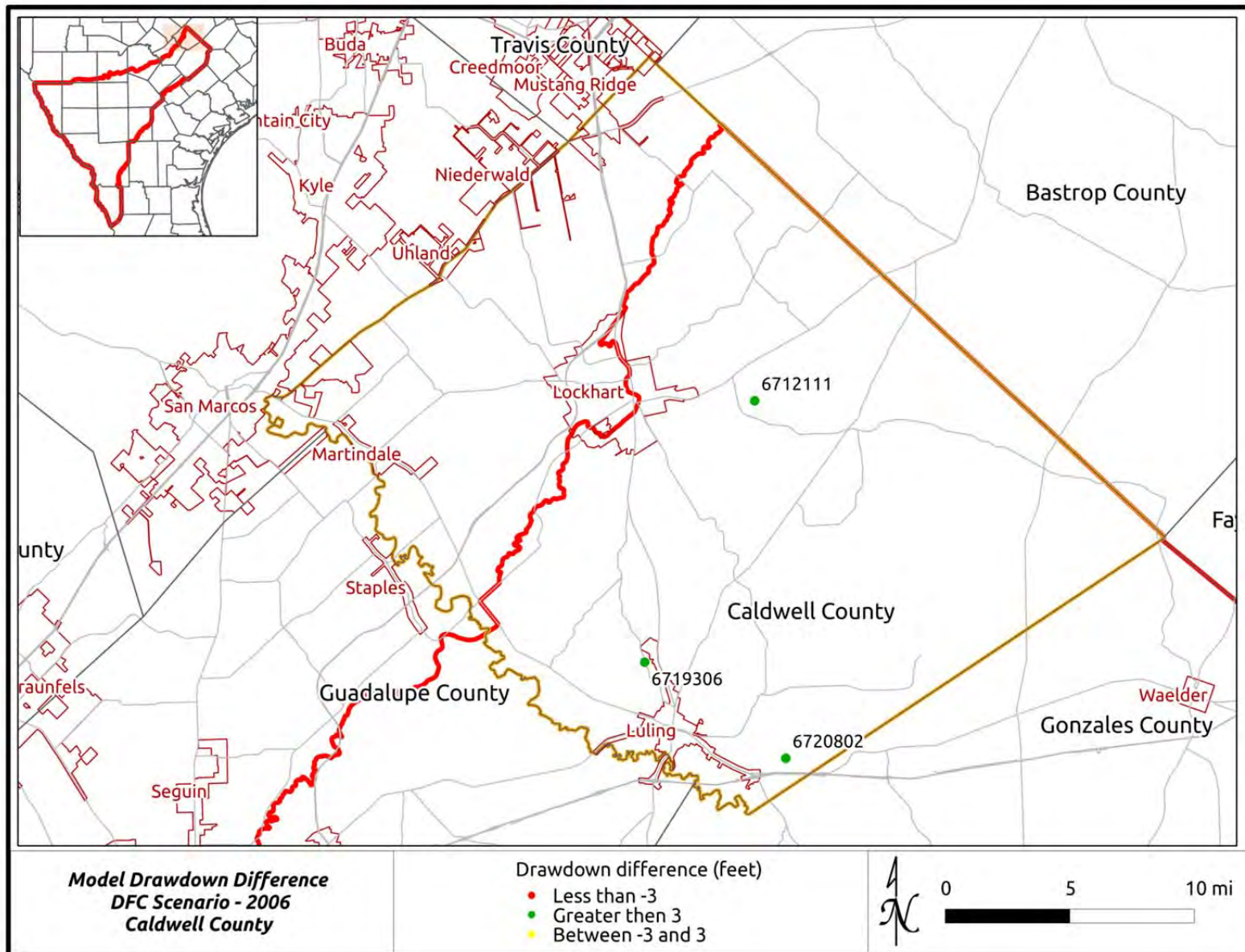

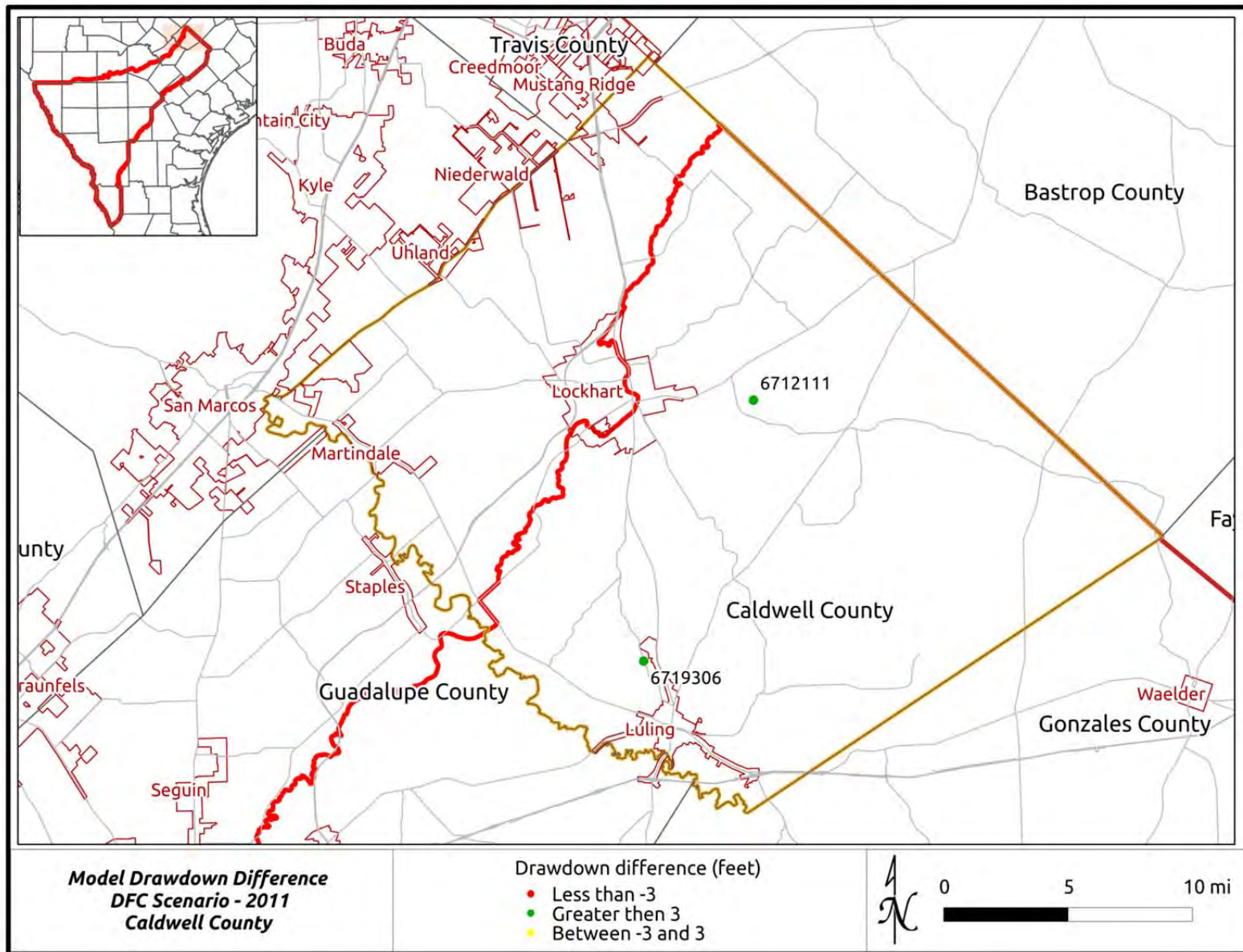

Summary of Drawdown Comparisons - Caldwell County

<i>Column 1</i>	<i>Column 2</i>	<i>Column 3</i>	<i>Column 4</i>	<i>Column 5</i>	<i>Column 6</i>	<i>Column 7</i>
Year	Precipitation (% Avg)	County-Wide Average DFC	Number of Actual Drawdown Data Points	Average Actual Drawdown for Wells with Data	Average DFC for Wells with Data	Column 6 minus Column 5
2000	90	7.71	3	-0.87	3.25	4.12
2001	101	11.65	3	-1.66	5.85	7.51
2002	113	14.31	3	-2.86	8.17	11.03
2003	96	16.77	3	-1.50	10.20	11.71
2004	132	18.88	3	-3.55	11.99	15.54
2005	75	20.71	3	-2.49	13.63	16.11
2006	86	22.26	3	-3.79	15.17	18.96
2007	142	23.80	3	-1.29	16.64	17.92
2008	74	25.26	3	-0.90	18.04	18.94
2009	76	26.02	3	-0.69	19.38	20.07
2010	132	26.80	2	0.40	26.43	26.03
2011	45	27.84	2	0.36	28.04	27.68

Caldwell County - All Years

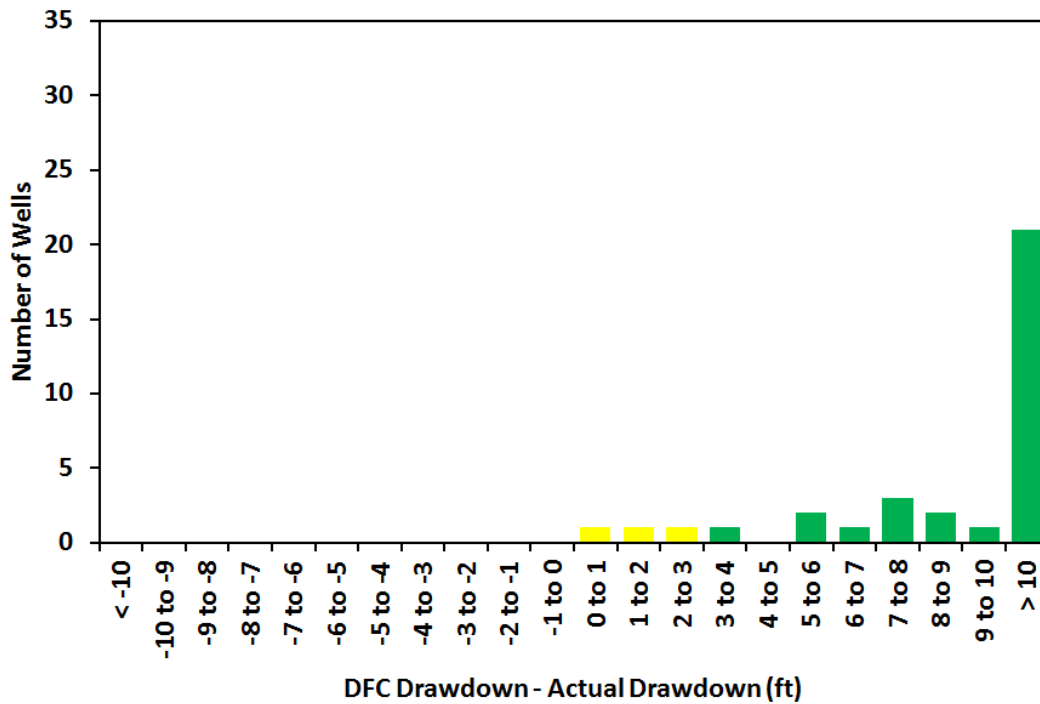

Caldwell County

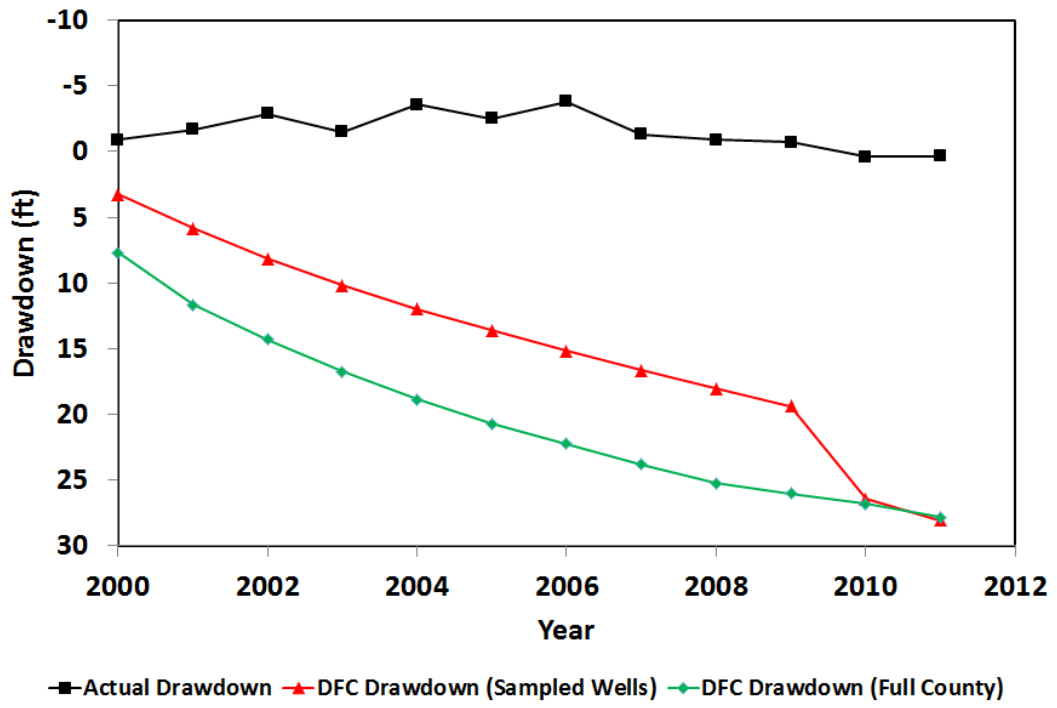

Appendix 5 – Dimmit County

Location Map of Hydrograph Wells

Hydrographs

Note that pumping data are expressed in three zones:

- Pump 1 = pumping from cell where well is located
- Pump 2 = pumping in cells adjacent to Zone 1
- Pump 3 = pumping in cells adjacent to Zone 2

Screen Bottom and Screen Top = Elevation of Well Completion Interval

Land Surface = Elevation of Land Surface at Well

Groundwater Elevations

- Measured = Actual data from TWDB database
- Calibrated Model = Results for cell defined by well from calibrated model
- DFC = Results for cell defined by well from Scenario 4 of GAM Run 09-034

Drawdown Comparison Maps for 2001, 2006 and 2011

Summary of Drawdown Comparisons

Table analogous to Table 5 in text summarizing annual average drawdown (actual and DFC)

Histogram of Differences between DFC Drawdown and Actual Drawdown for All Years

Figure analogous to Figure 23 in text showing differences between actual drawdown and DFC conditions

Hydrograph of Actual Drawdown and DFC Drawdown

Figure analogous to Figure 26 in text showing time history of drawdown (actual and DFC) from 2000 to 2011

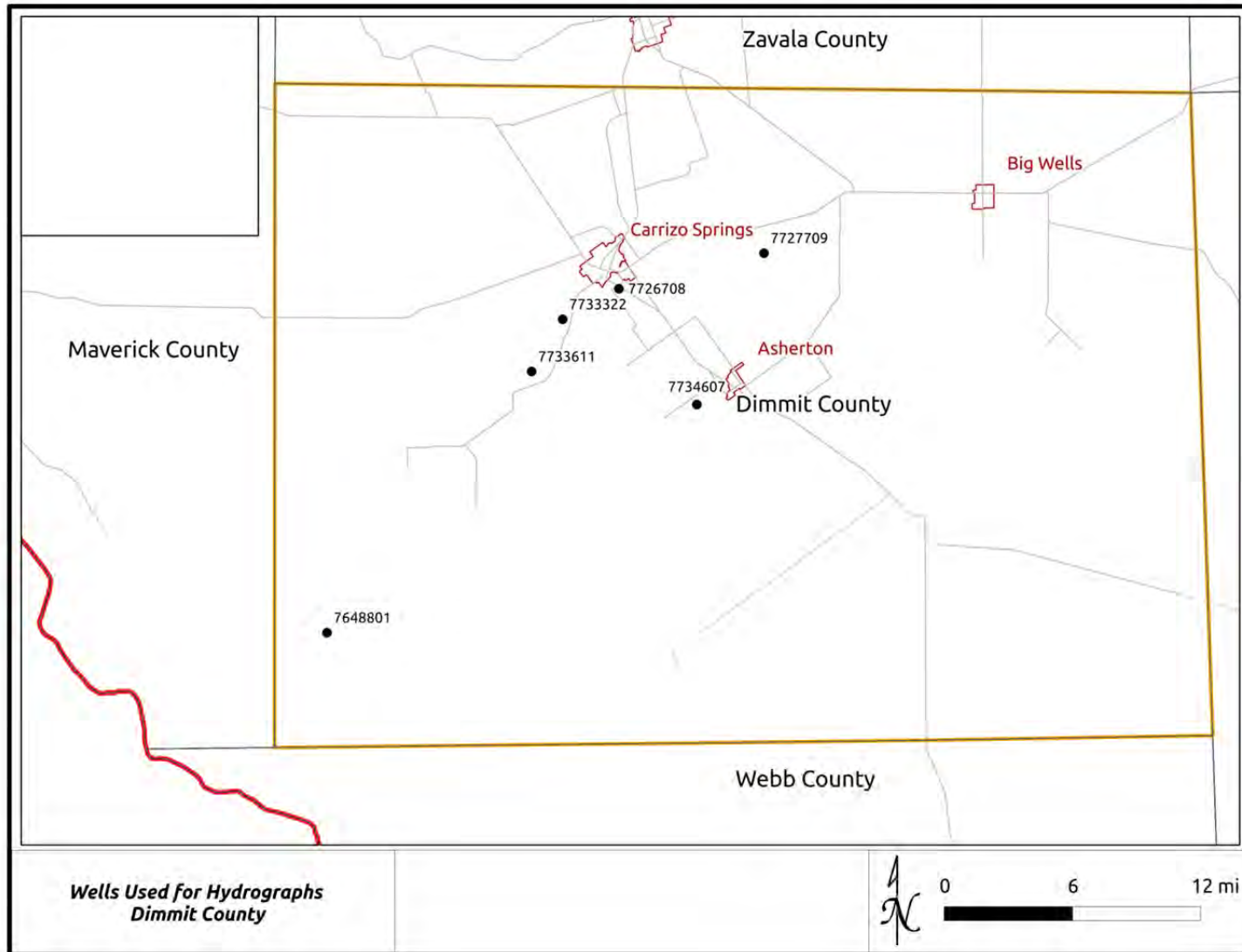

Location Map of Wells with Hydrographs – Dimmit County

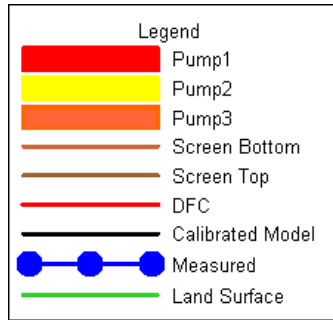

Well 7648801
Dimmit County - Layer 5

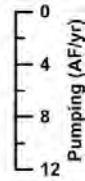
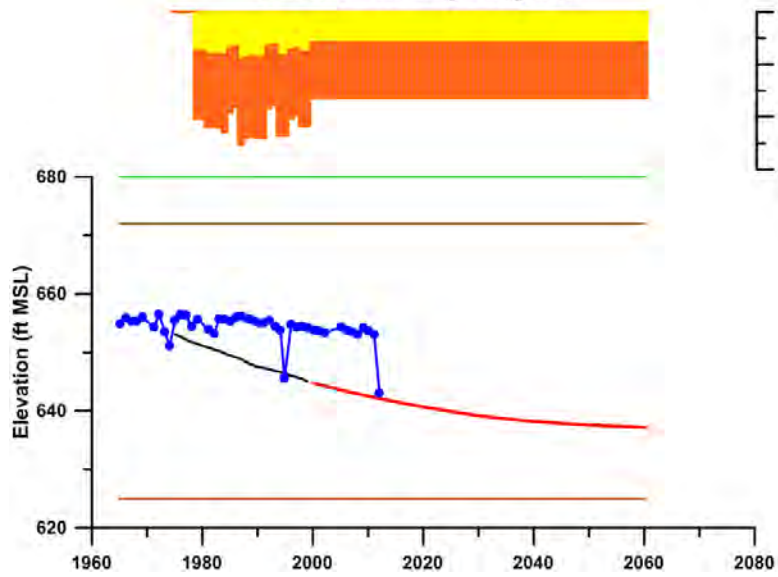

Well 7726708
Dimmit County - Layer 5

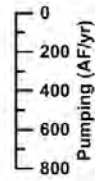
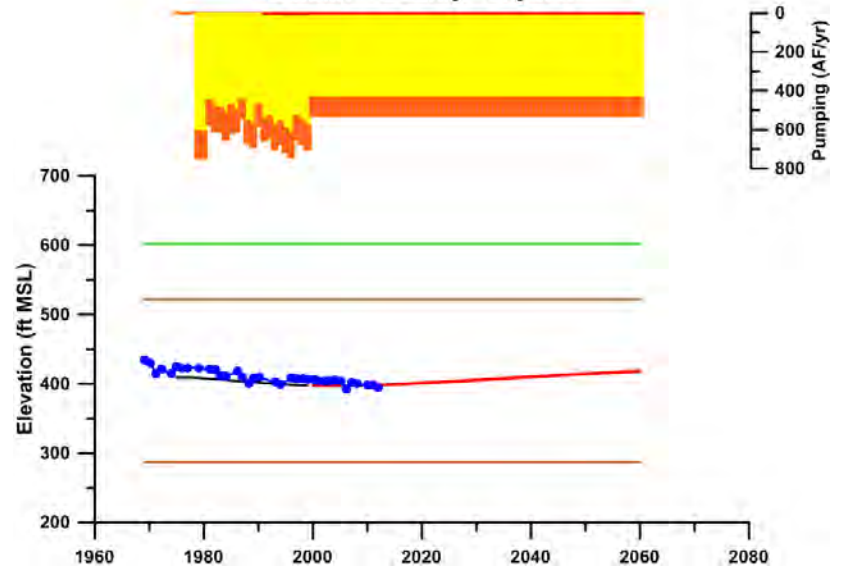

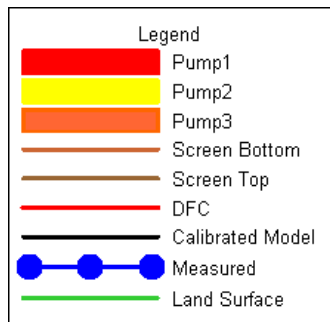
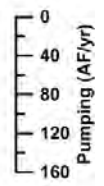
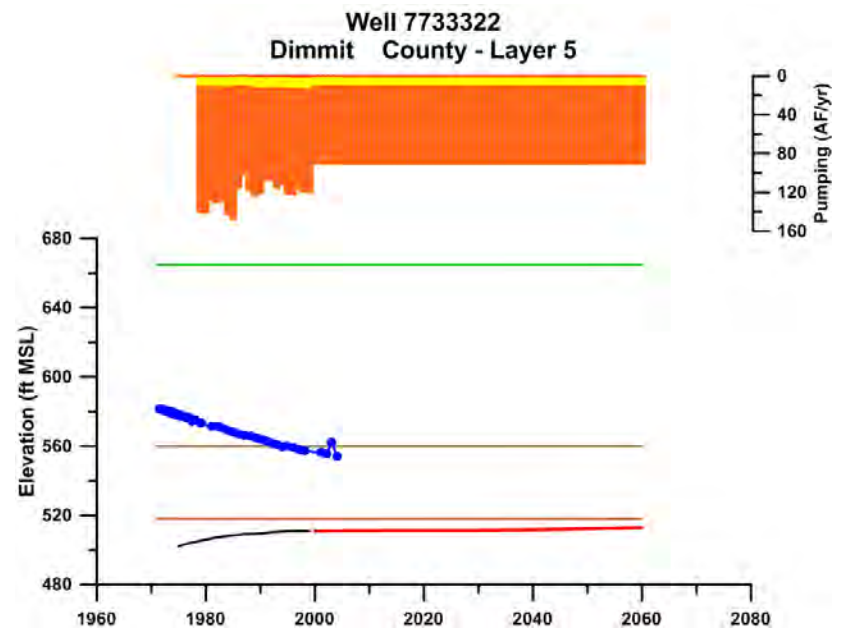
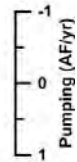
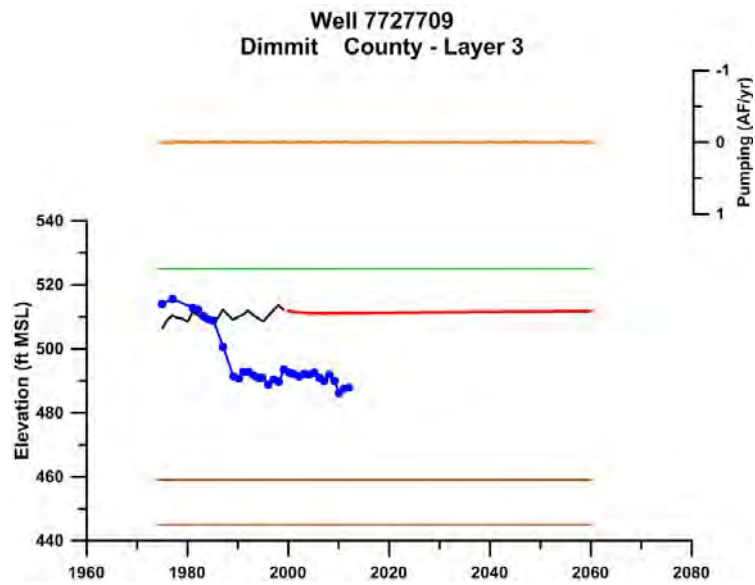

Well 7733611
Dimmit County - Layer 5

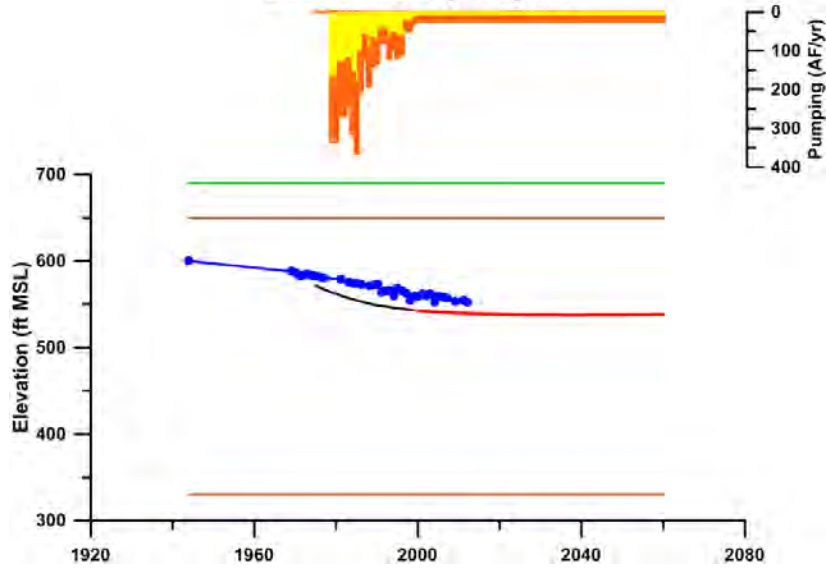

Well 7734607
Dimmit County - Layer 5

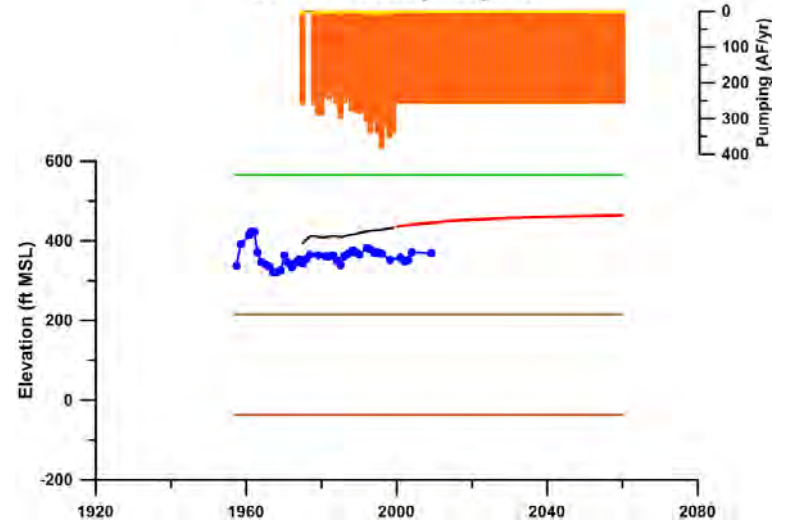

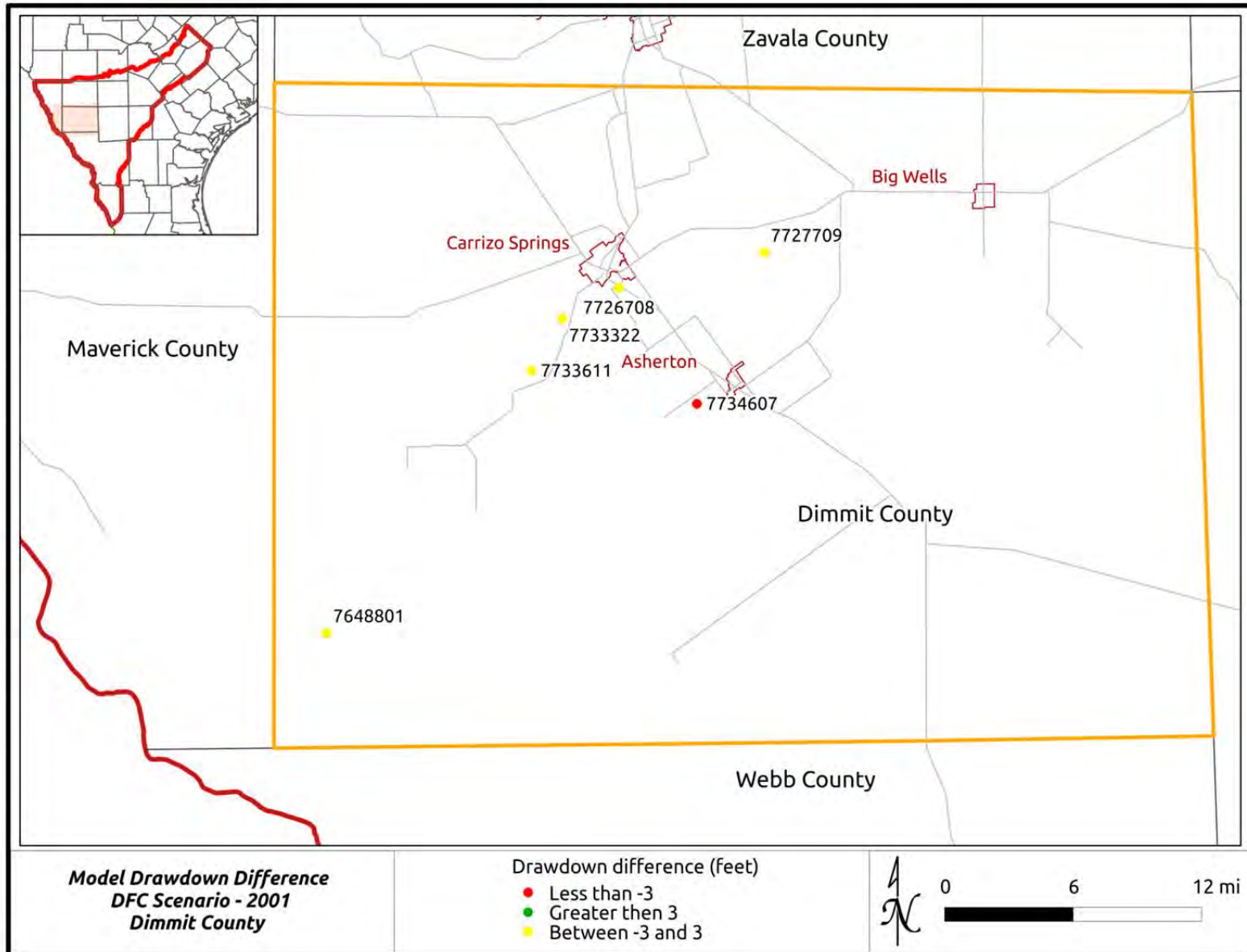

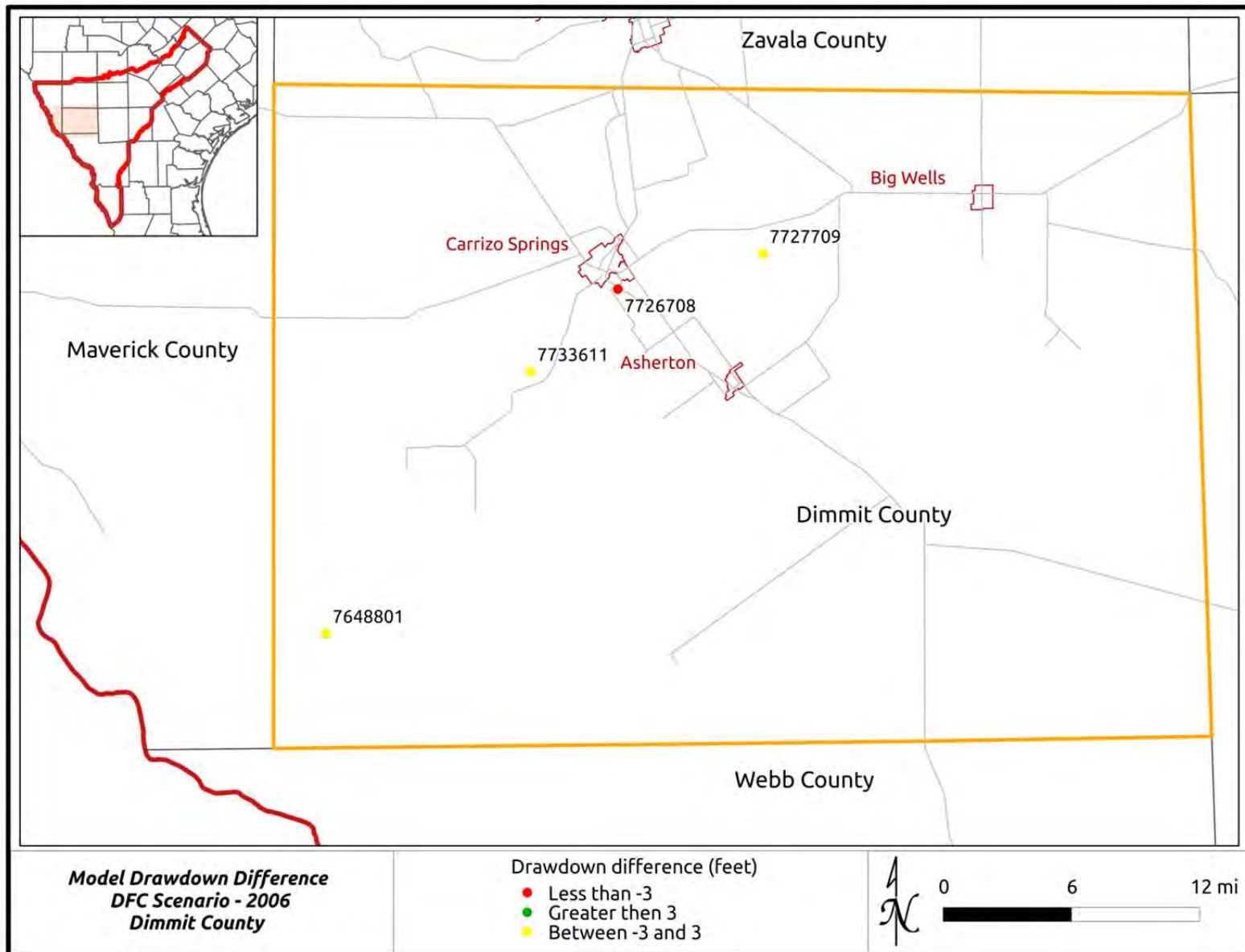

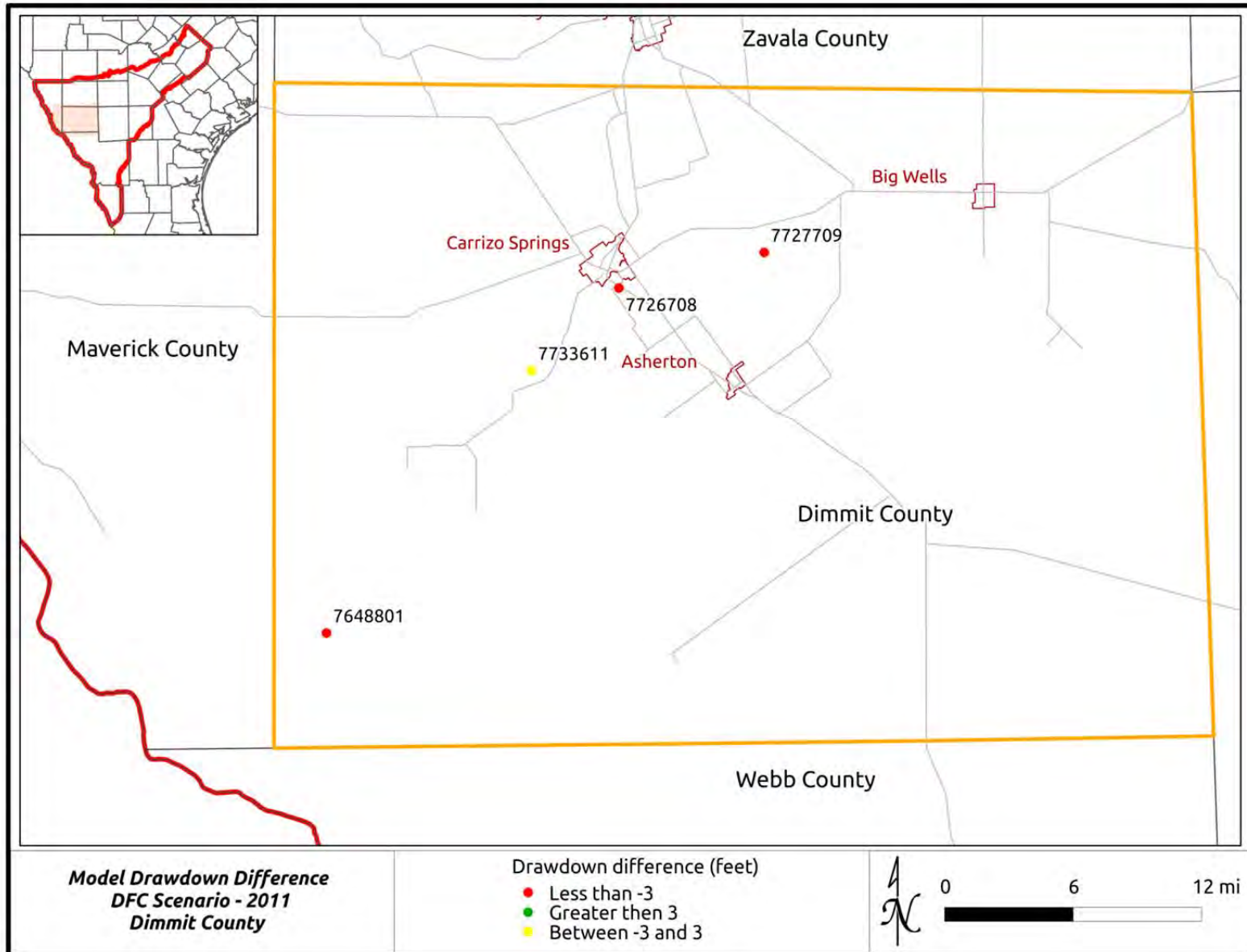

Summary of Drawdown Comparisons - Dimmit County

<i>Column 1</i>	<i>Column 2</i>	<i>Column 3</i>	<i>Column 4</i>	<i>Column 5</i>	<i>Column 6</i>	<i>Column 7</i>
Year	Precipitation (% Avg)	County-Wide Average DFC	Number of Actual Drawdown Data Points	Average Actual Drawdown for Wells with Data	Average DFC for Wells with Data	Column 6 minus Column 5
2000	90	-1.01	5	-0.20	0.24	0.44
2001	101	-1.85	6	2.07	-0.32	-2.39
2002	113	-2.57	5	0.17	-0.69	-0.86
2003	96	-3.2	5	-0.65	-0.86	-0.21
2004	132	-3.76	4	0.02	1.11	1.09
2005	75	-4.27	4	4.04	1.23	-2.81
2006	86	-4.73	4	2.17	1.34	-0.83
2007	142	-5.14	3	2.30	1.06	-1.24
2008	74	-5.54	4	-0.54	-1.39	-0.85
2009	76	-5.9	3	4.89	1.09	-3.80
2010	132	-6.29	4	4.31	1.62	-2.70
2011	45	-6.74	4	8.12	1.66	-6.46

Dimmit County - All Years

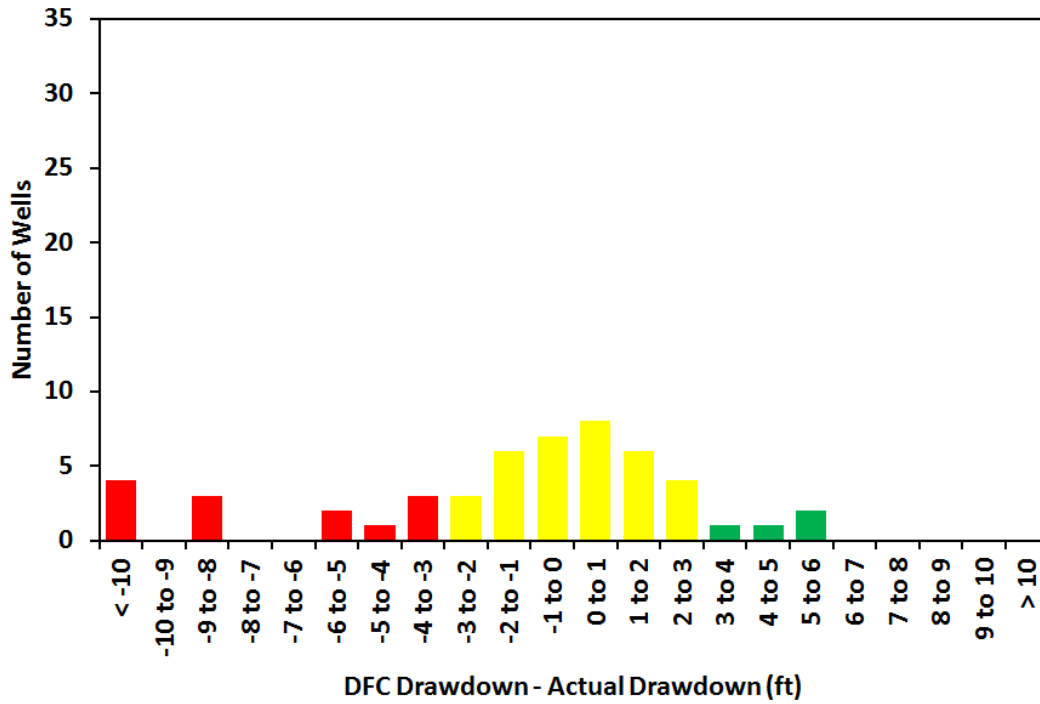

Dimmit County

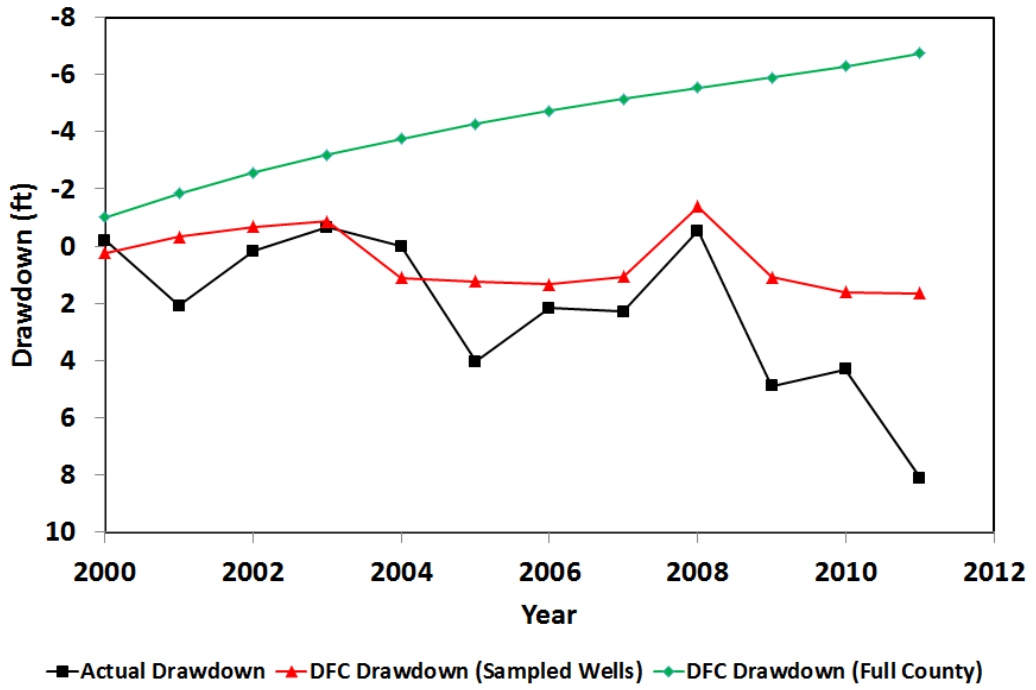

Appendix 6 – Frio County

Location Map of Hydrograph Wells

Hydrographs

Note that pumping data are expressed in three zones:

- Pump 1 = pumping from cell where well is located
- Pump 2 = pumping in cells adjacent to Zone 1
- Pump 3 = pumping in cells adjacent to Zone 2

Screen Bottom and Screen Top = Elevation of Well Completion Interval

Land Surface = Elevation of Land Surface at Well

Groundwater Elevations

- Measured = Actual data from TWDB database
- Calibrated Model = Results for cell defined by well from calibrated model
- DFC = Results for cell defined by well from Scenario 4 of GAM Run 09-034

Drawdown Comparison Maps for 2001 and 2006

Summary of Drawdown Comparisons

Table analogous to Table 5 in text summarizing annual average drawdown (actual and DFC)

Histogram of Differences between DFC Drawdown and Actual Drawdown for All Years

Figure analogous to Figure 23 in text showing differences between actual drawdown and DFC conditions

Hydrograph of Actual Drawdown and DFC Drawdown

Figure analogous to Figure 26 in text showing time history of drawdown (actual and DFC) from 2000 to 2011

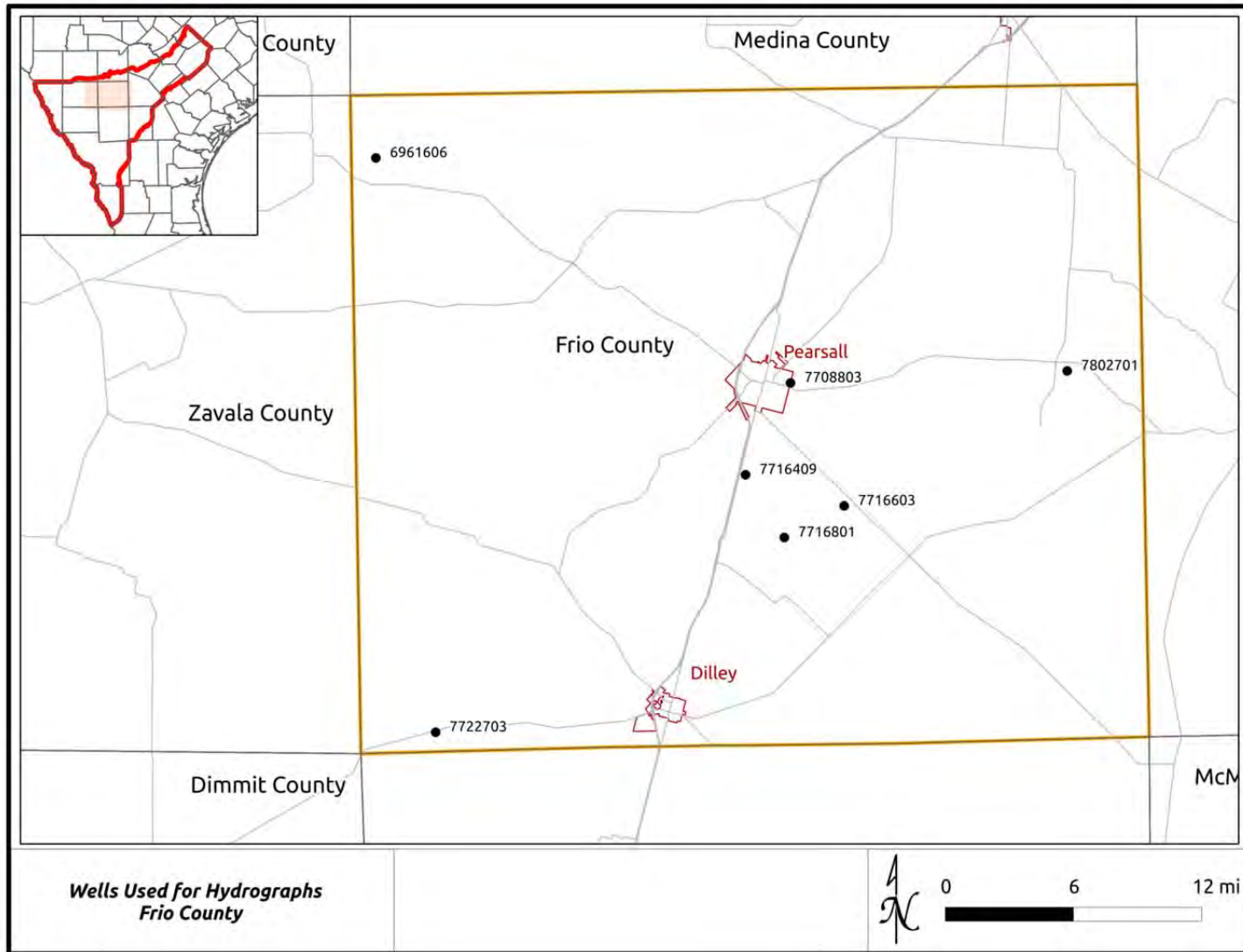

Location Map of Wells with Hydrographs – Frio County

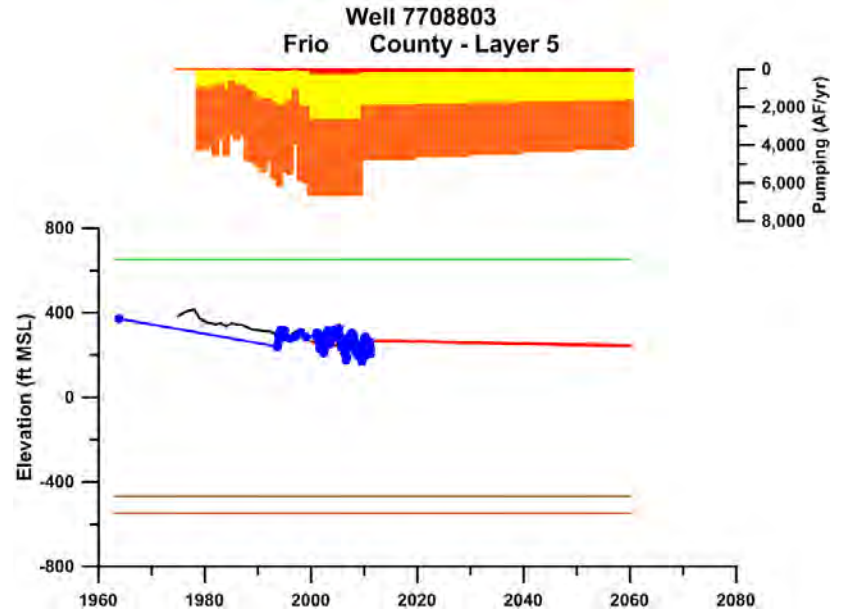
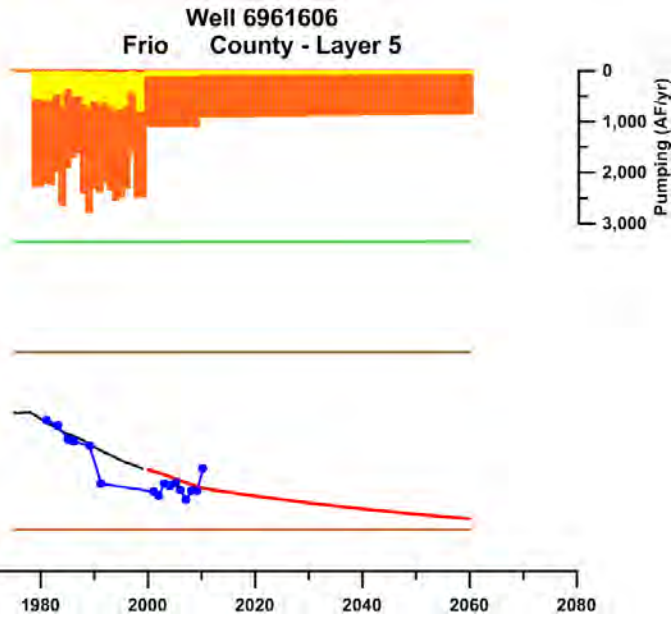
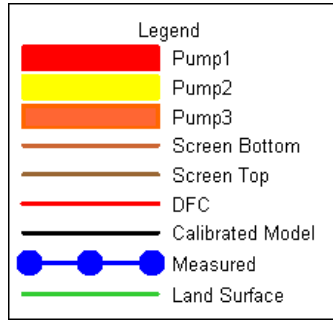

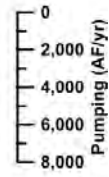
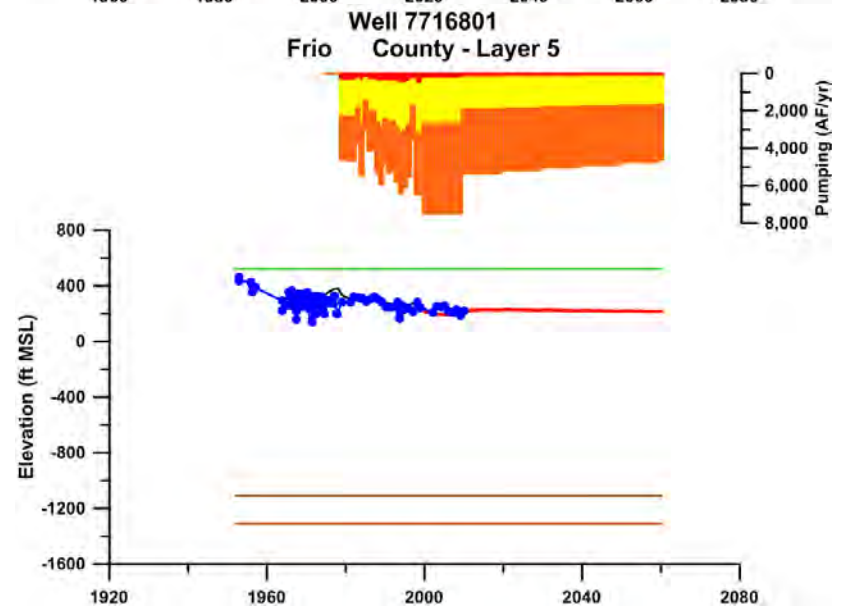
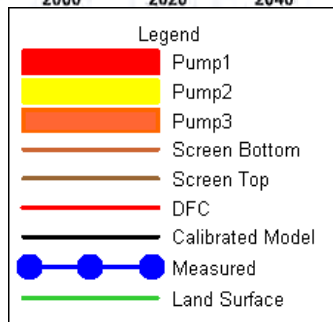
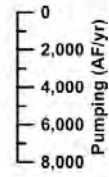
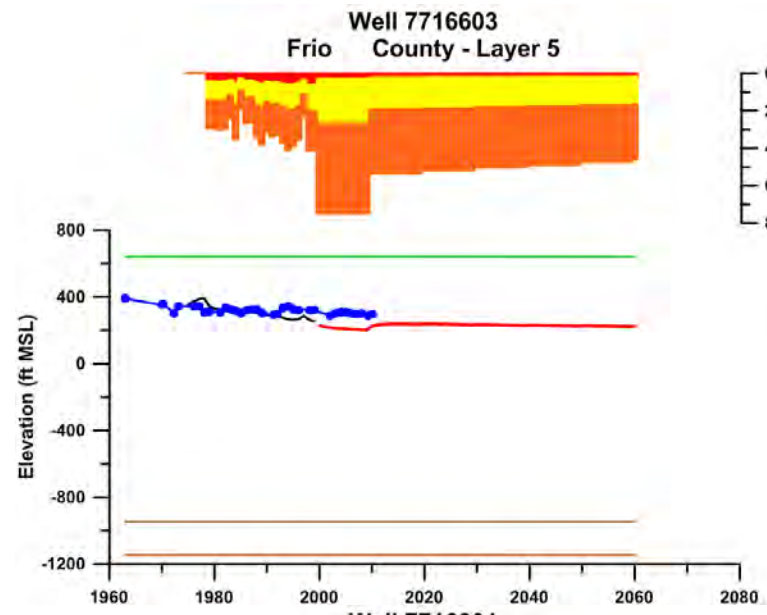
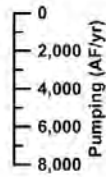
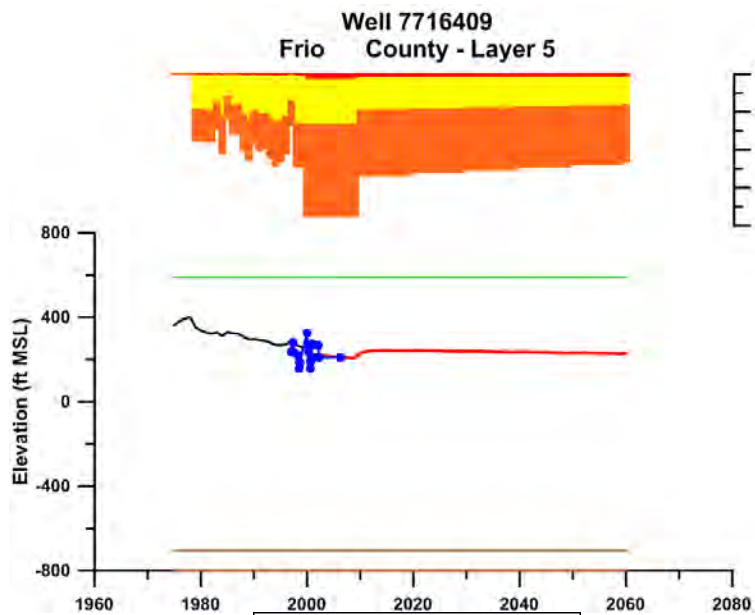

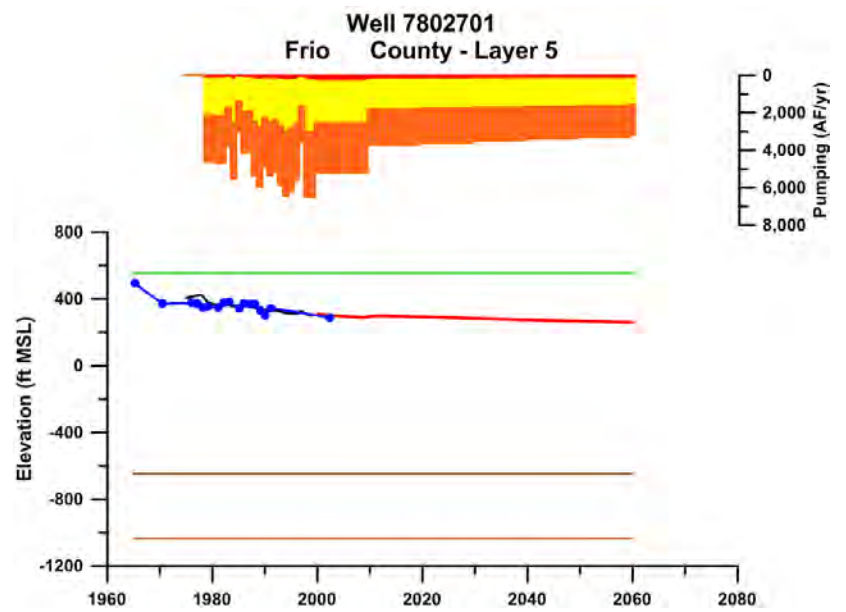
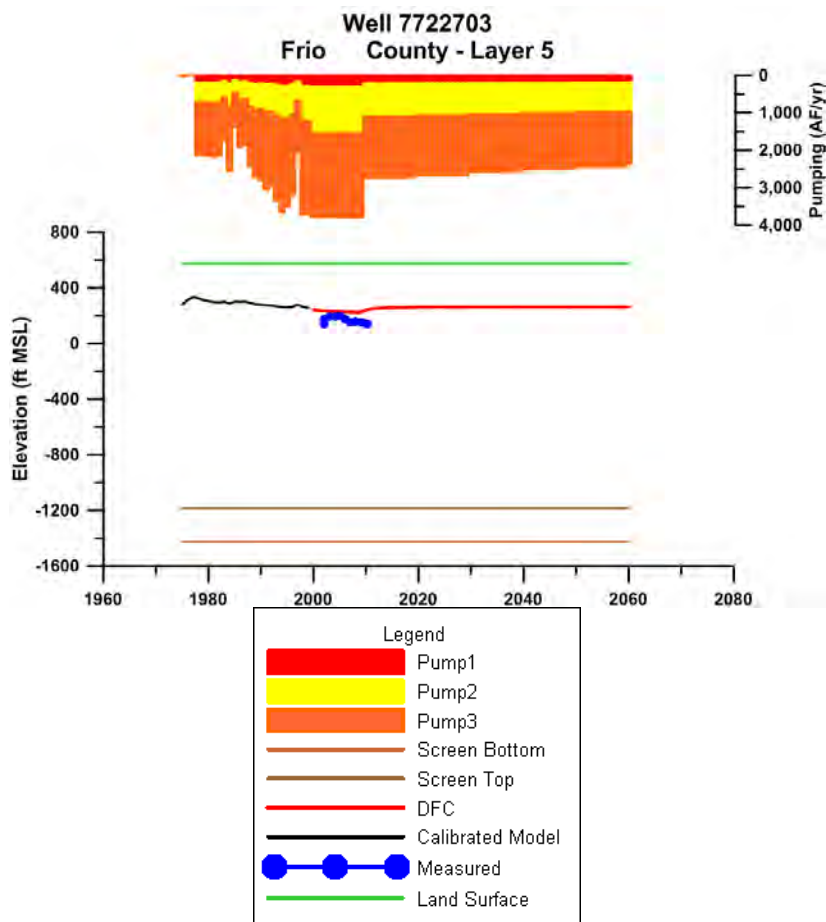

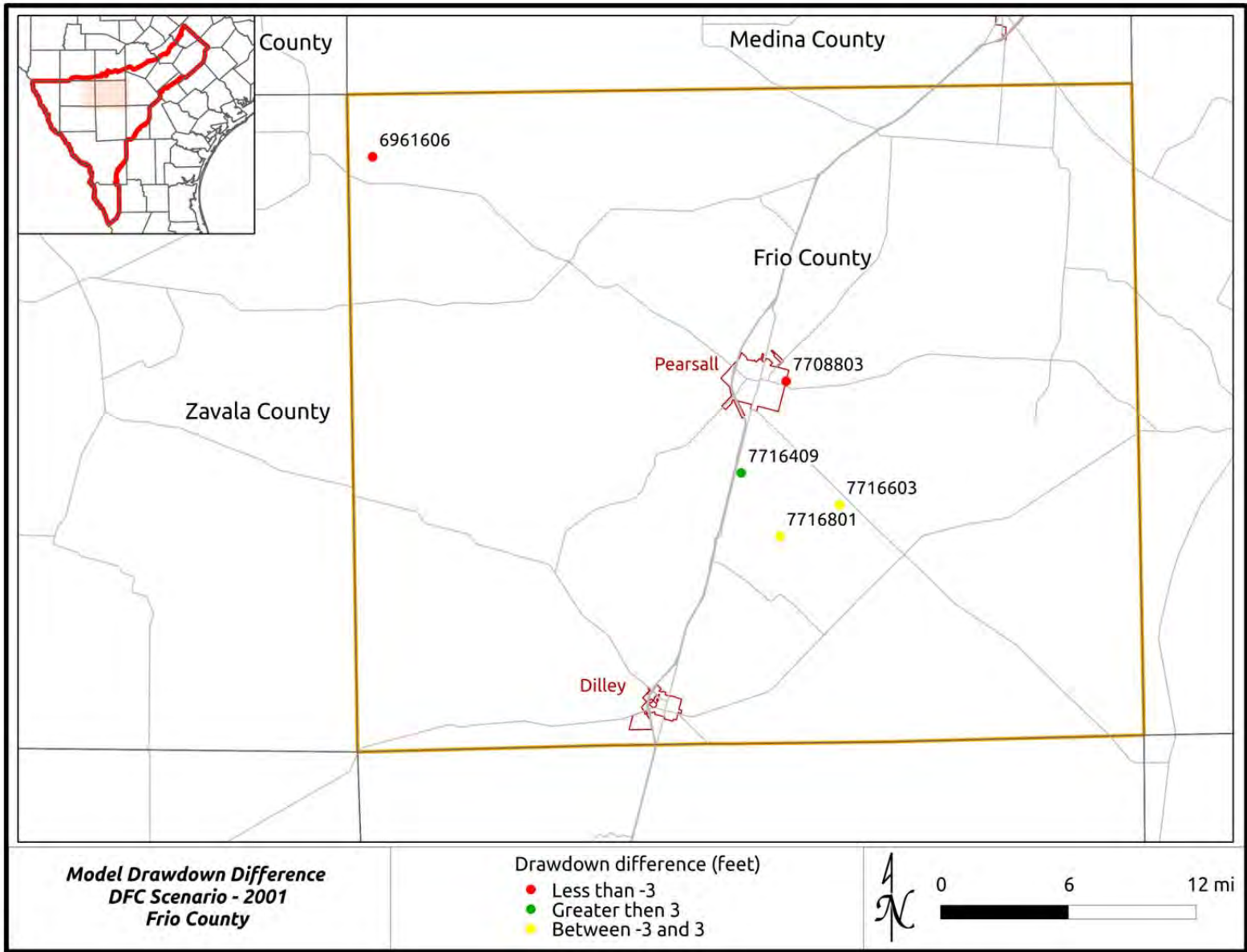

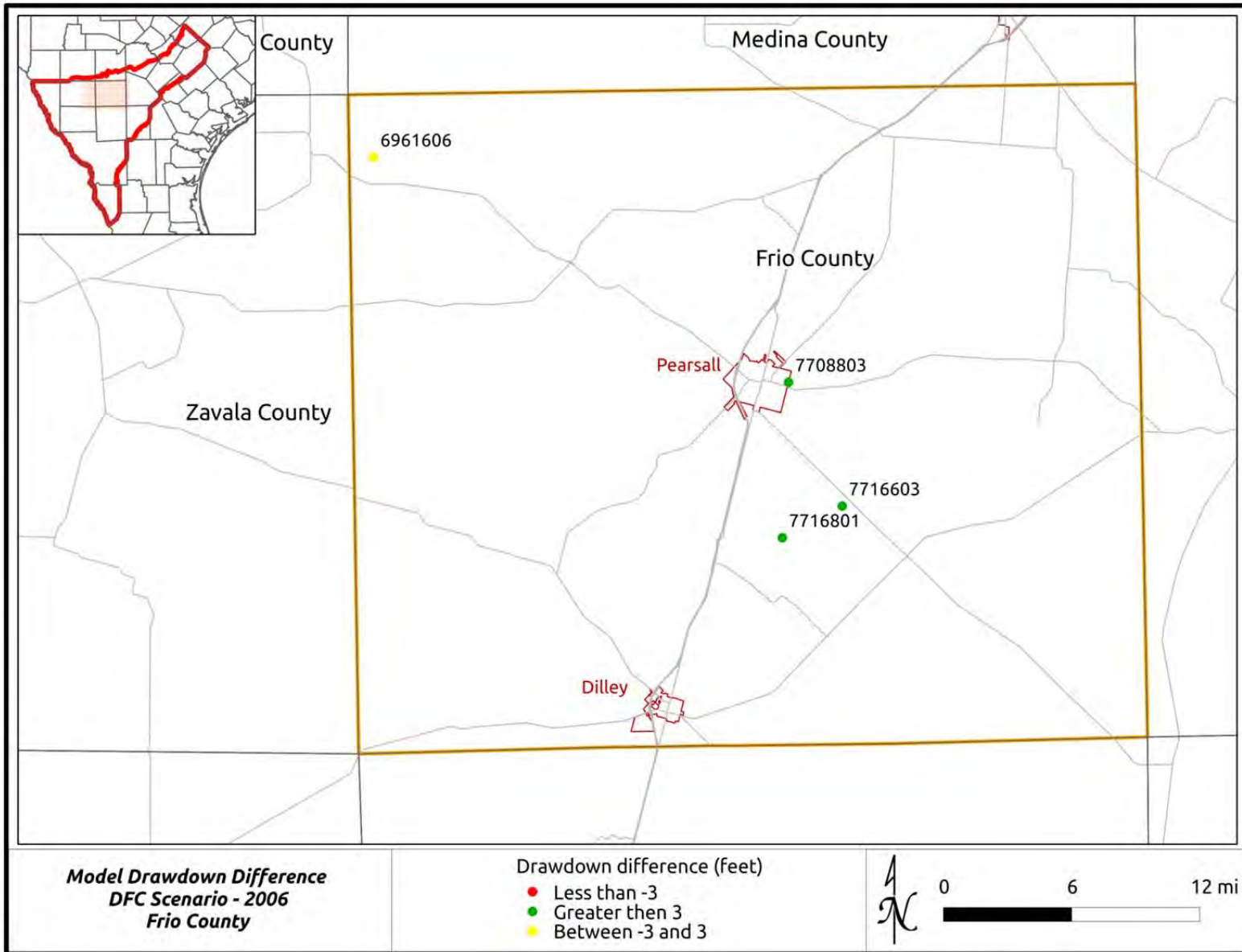

Summary of Drawdown Comparisons - Frio County

<i>Column 1</i>	<i>Column 2</i>	<i>Column 3</i>	<i>Column 4</i>	<i>Column 5</i>	<i>Column 6</i>	<i>Column 7</i>
Year	Precipitation (% Avg)	County-Wide Average DFC	Number of Actual Drawdown Data Points	Average Actual Drawdown for Wells with Data	Average DFC for Wells with Data	Column 6 minus Column 5
2000	90	3.62	3	-14.90	14.52	29.42
2001	101	5.87	5	18.66	25.16	6.50
2002	113	7.58	4	-2.33	26.98	29.31
2003	96	9.03	4	-3.04	29.82	32.86
2004	132	10.35	4	-10.42	32.29	42.71
2005	75	11.57	4	21.59	34.55	12.96
2006	86	12.72	4	25.56	36.67	11.11
2007	142	13.83	4	20.84	38.68	17.84
2008	74	14.91	4	40.58	40.61	0.03
2009	76	15.96	3	21.67	49.80	28.13
2010	132	12.57	1	85.85	24.21	-61.64
2011	45	11.1				

Frio County - All Years

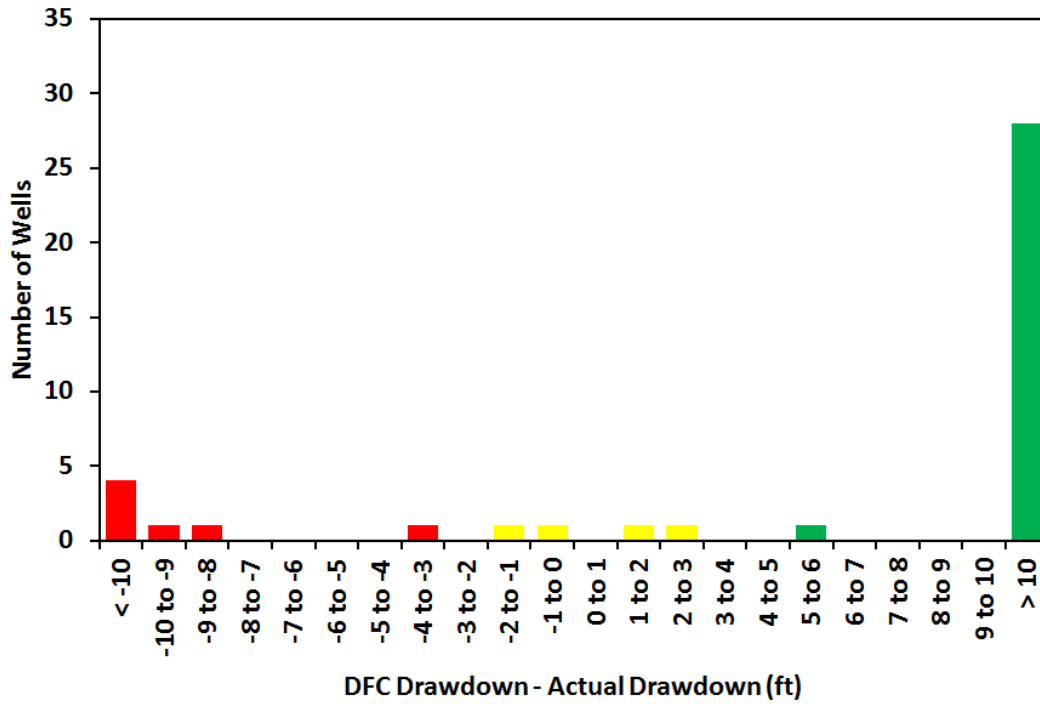

Frio County

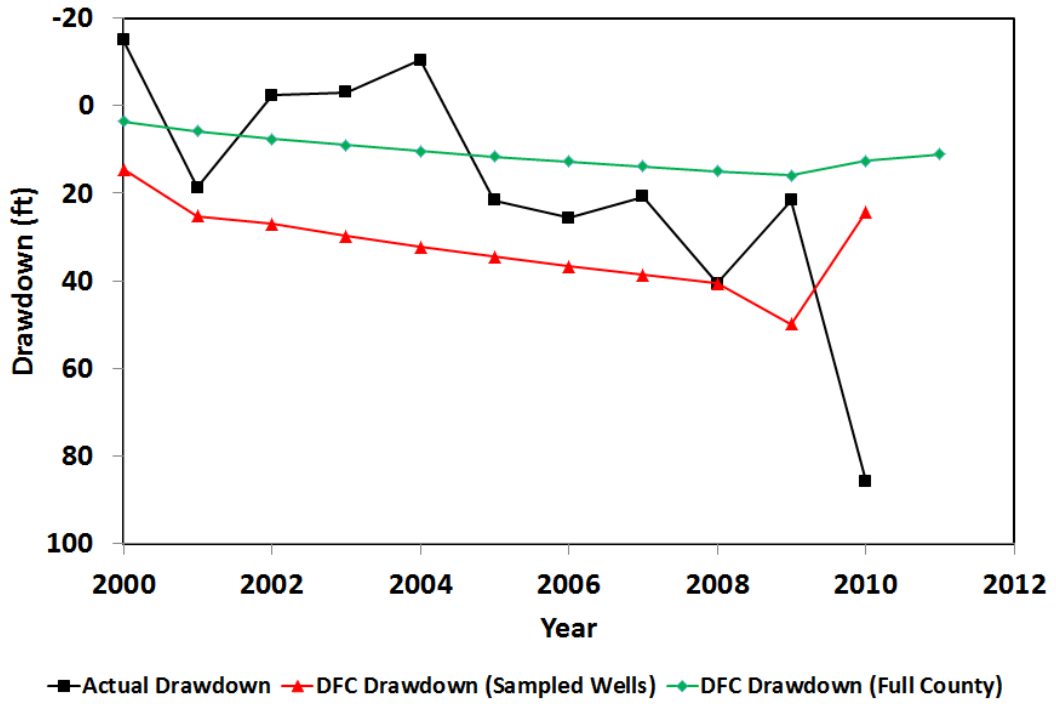

Appendix 7 – Gonzales County

Location Map of Hydrograph Wells

Hydrographs

Note that pumping data are expressed in three zones:

- Pump 1 = pumping from cell where well is located
- Pump 2 = pumping in cells adjacent to Zone 1
- Pump 3 = pumping in cells adjacent to Zone 2

Screen Bottom and Screen Top = Elevation of Well Completion Interval

Land Surface = Elevation of Land Surface at Well

Groundwater Elevations

- Measured = Actual data from TWDB database
- Calibrated Model = Results for cell defined by well from calibrated model
- DFC = Results for cell defined by well from Scenario 4 of GAM Run 09-034

Drawdown Comparison Map for 2001

Summary of Drawdown Comparisons

Table analogous to Table 5 in text summarizing annual average drawdown (actual and DFC)

Histogram of Differences between DFC Drawdown and Actual Drawdown for All Years

Figure analogous to Figure 23 in text showing differences between actual drawdown and DFC conditions

Hydrograph of Actual Drawdown and DFC Drawdown

Figure analogous to Figure 26 in text showing time history of drawdown (actual and DFC) from 2000 to 2011

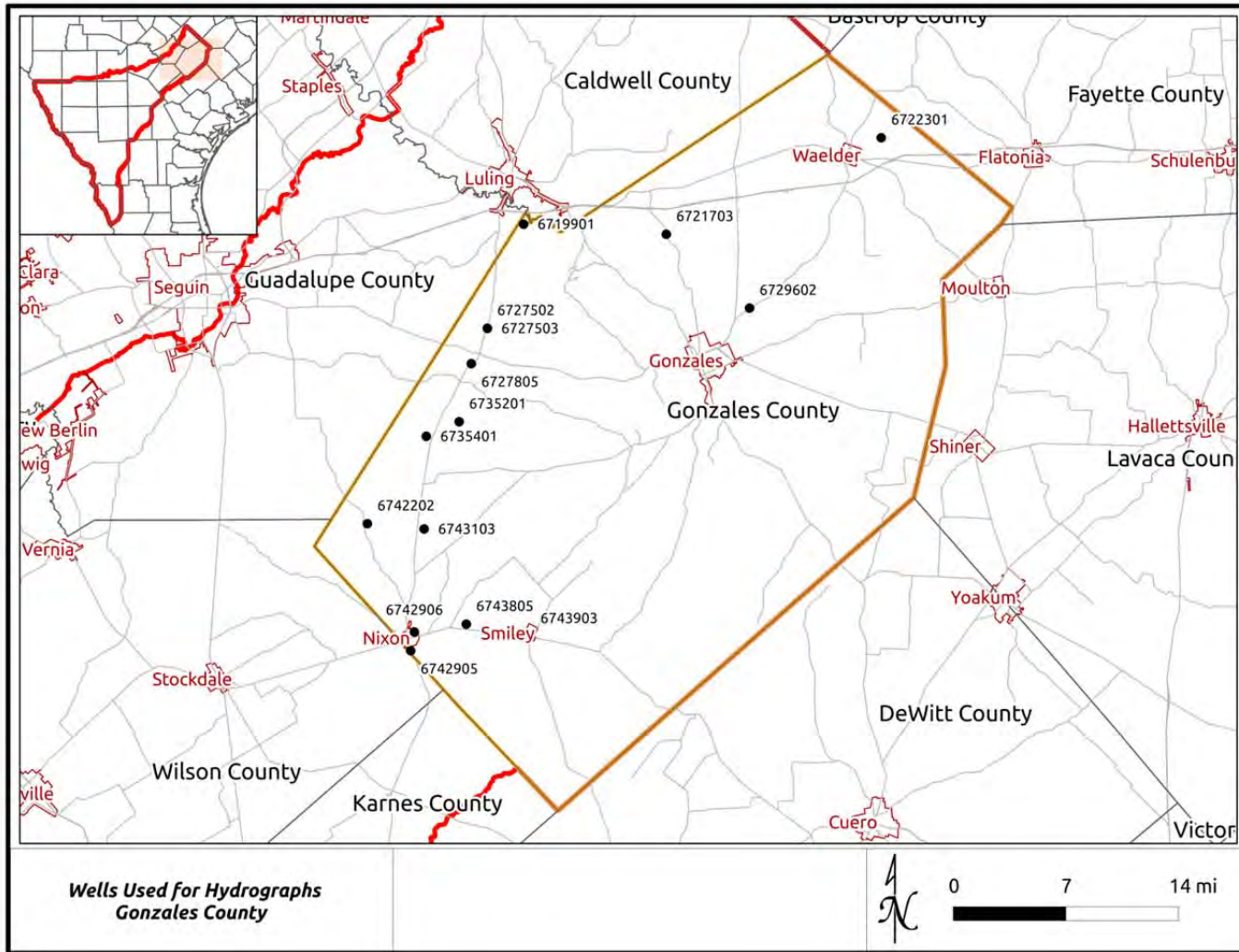

Location Map of Wells with Hydrographs – Gonzales County

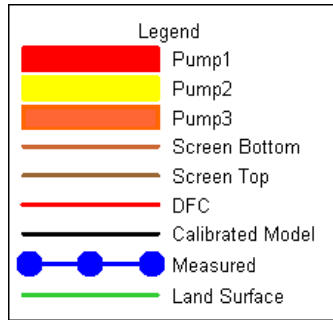

**Well 6719901
Gonzales County - Layer 7**

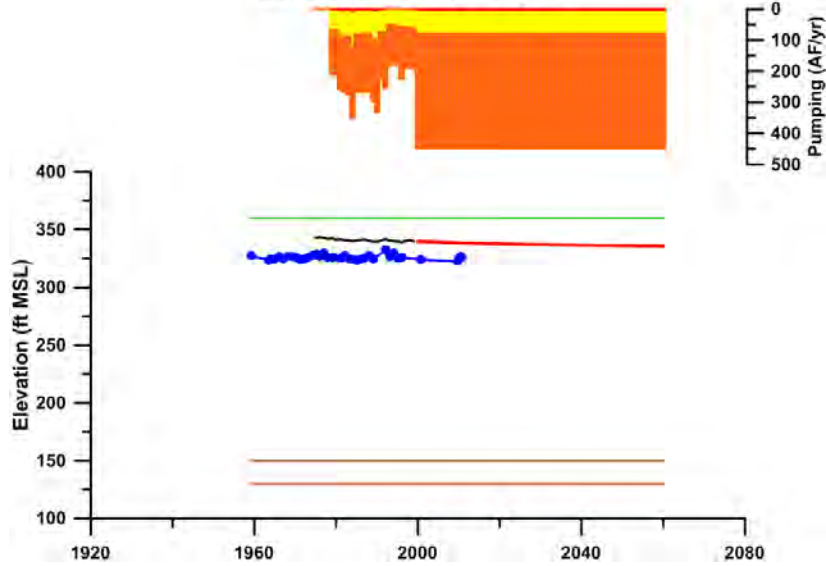

**Well 6721703
Gonzales County - Layer 5**

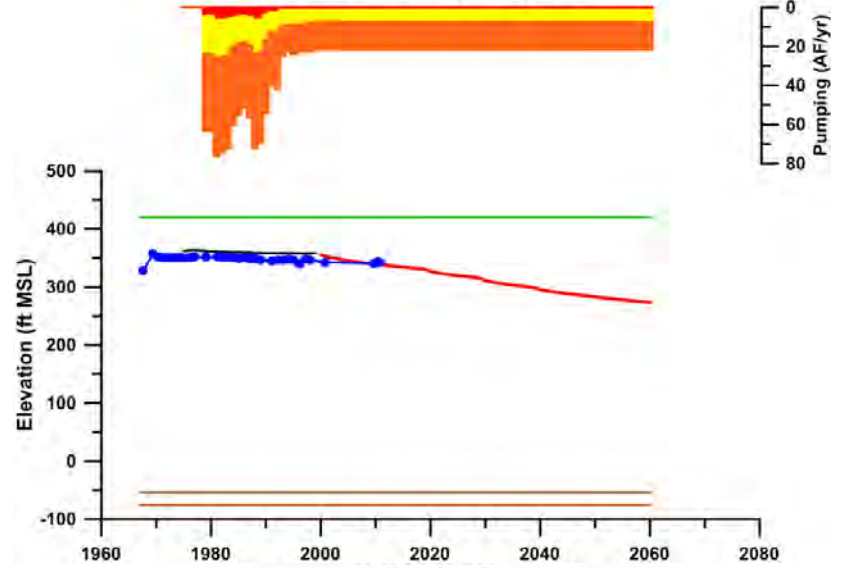

**Well 6722301
Gonzales County - Layer 1**

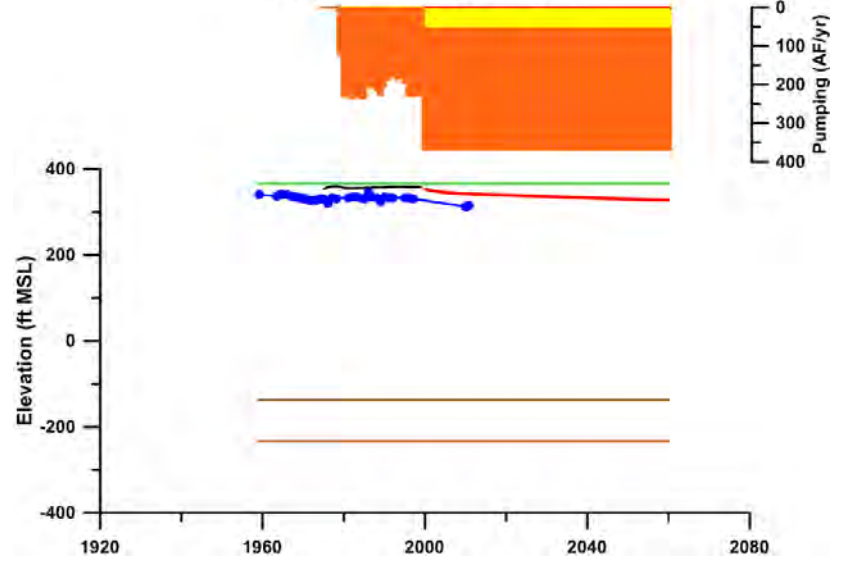

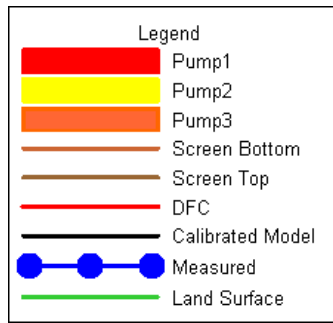

**Well 6727502
Gonzales County - Layer 5**

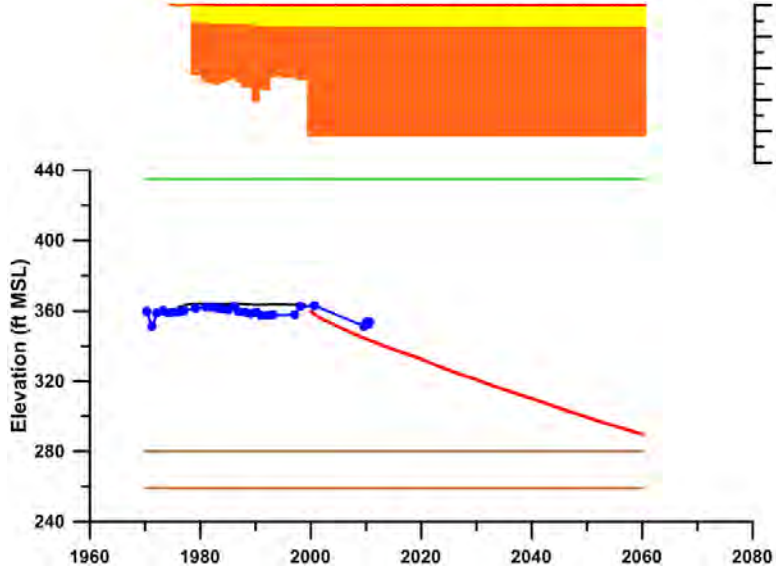

**Well 6727503
Gonzales County - Layer 5**

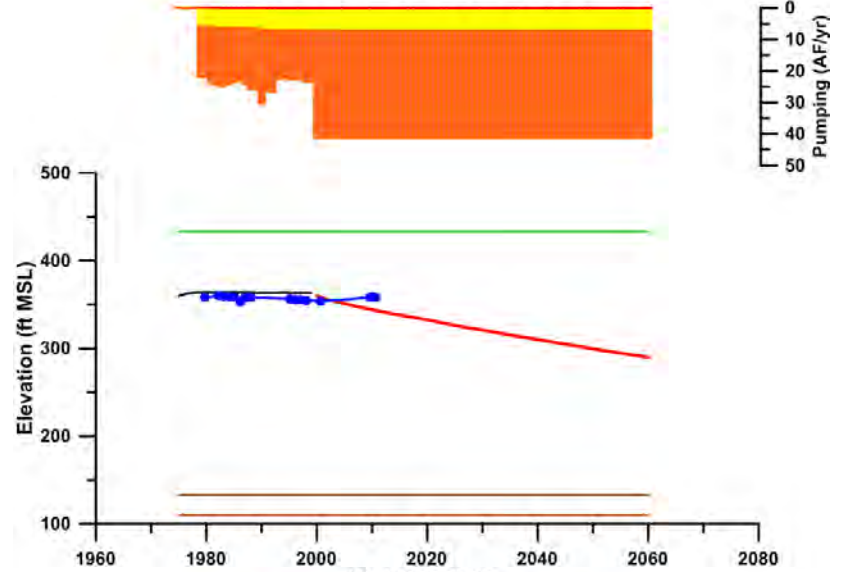

**Well 6727805
Gonzales County - Layer 5**

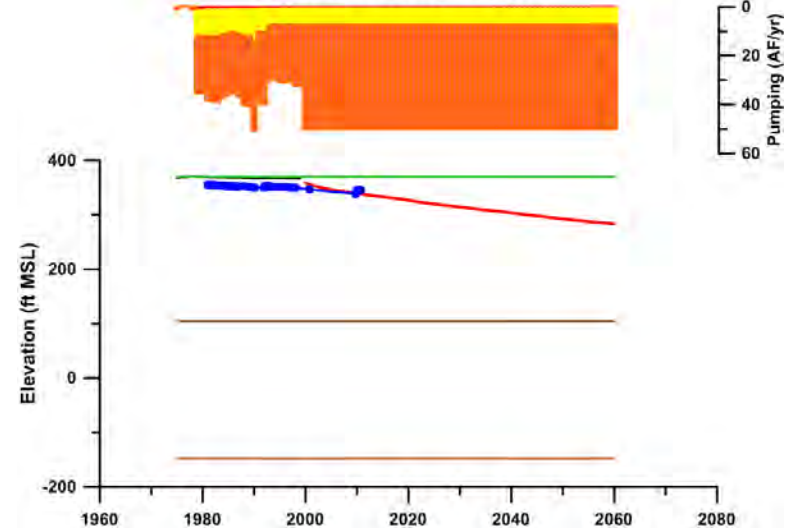

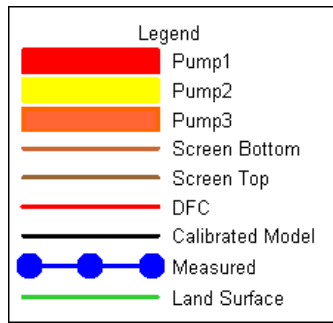

Well 6729602
Gonzales County - Layer 4

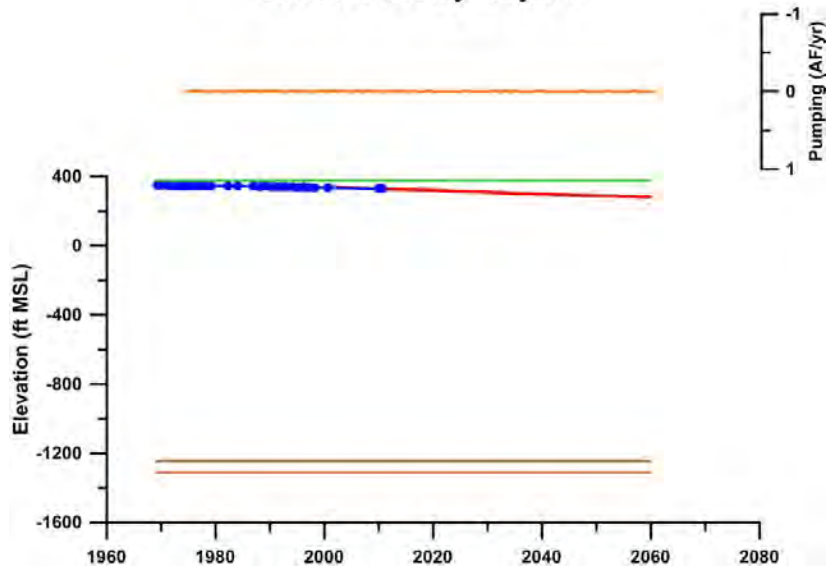

Well 6735201
Gonzales County - Layer 5

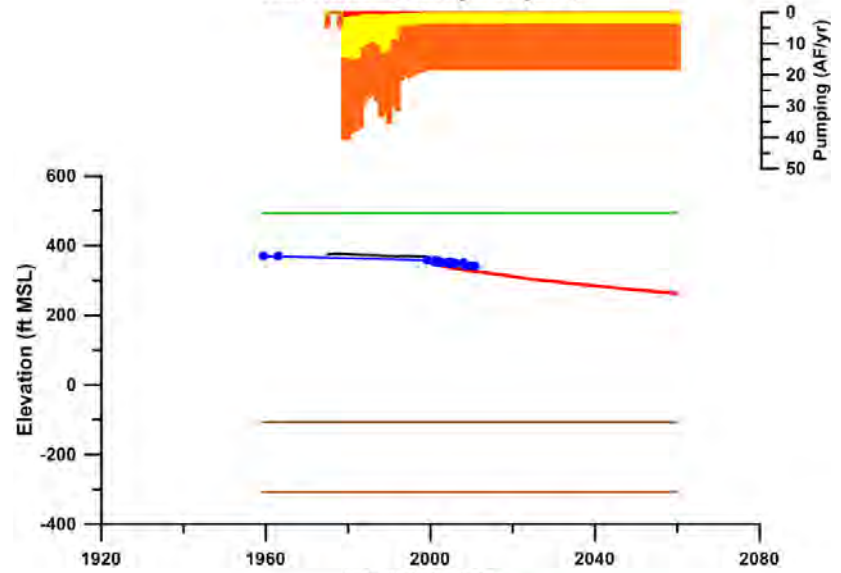

Well 6735401
Gonzales County - Layer 5

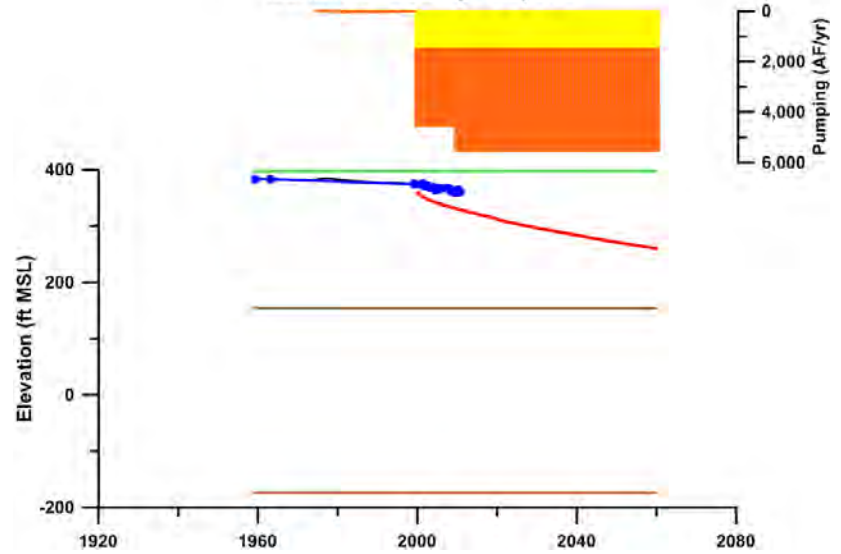

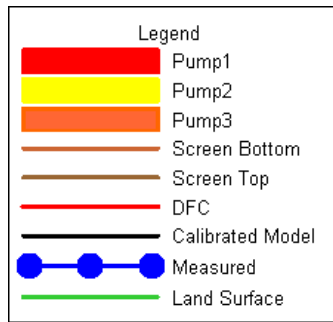

**Well 6742202
Gonzales County - Layer 5**

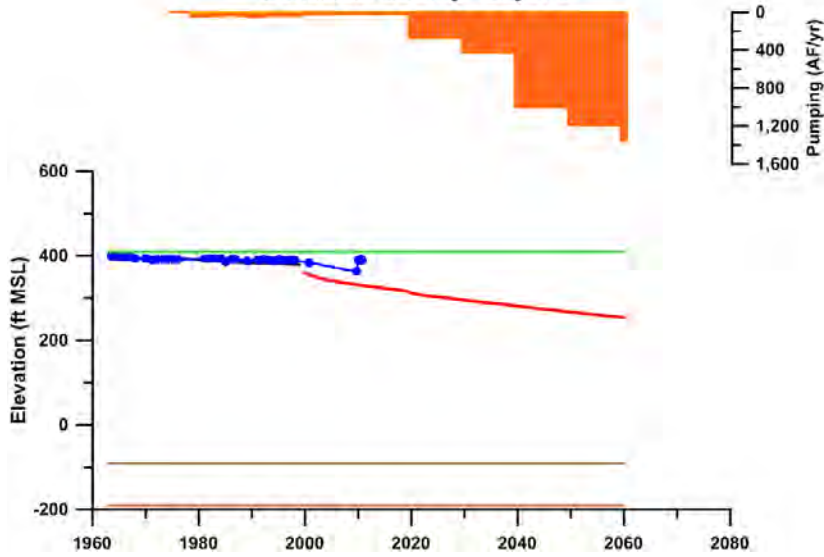

**Well 6742905
Gonzales County - Layer 5**

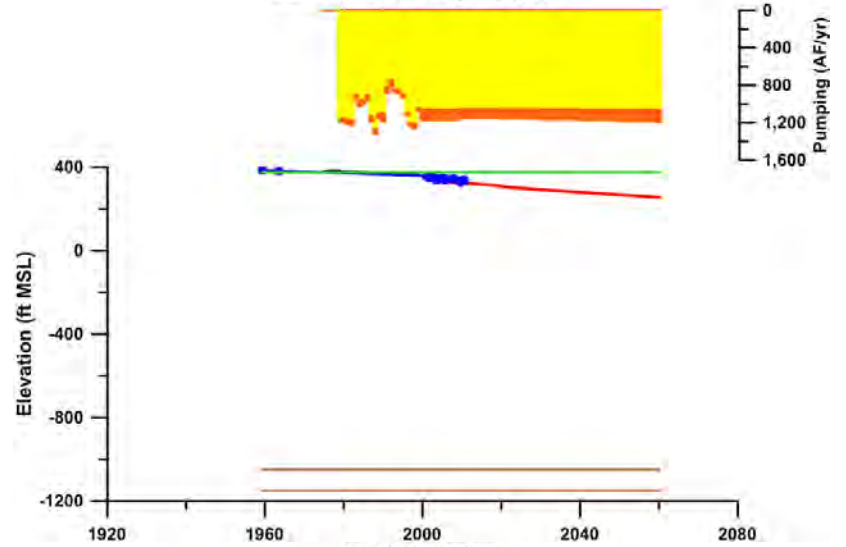

**Well 6742906
Gonzales County - Layer 5**

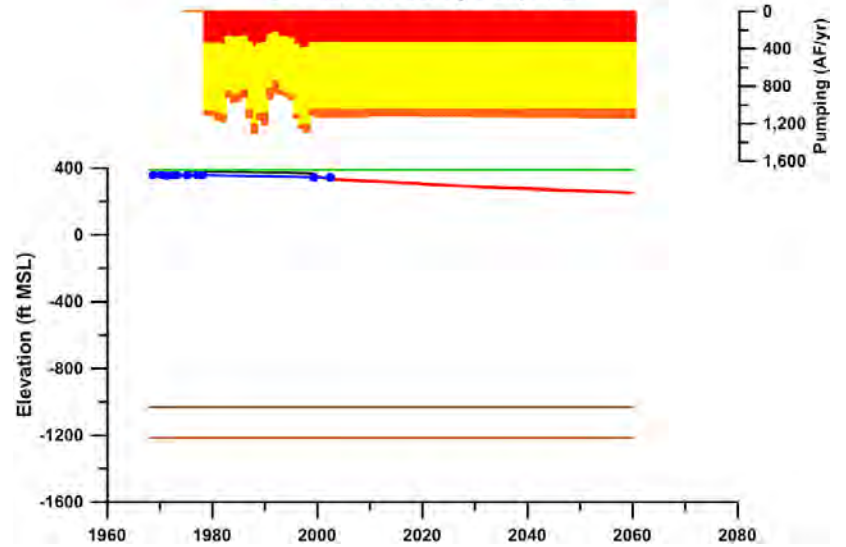

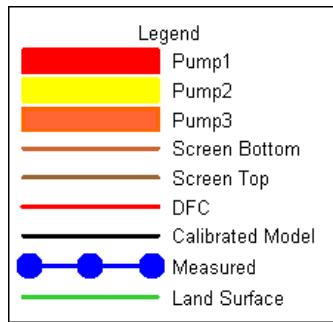

**Well 6743103
Gonzales County - Layer 5**

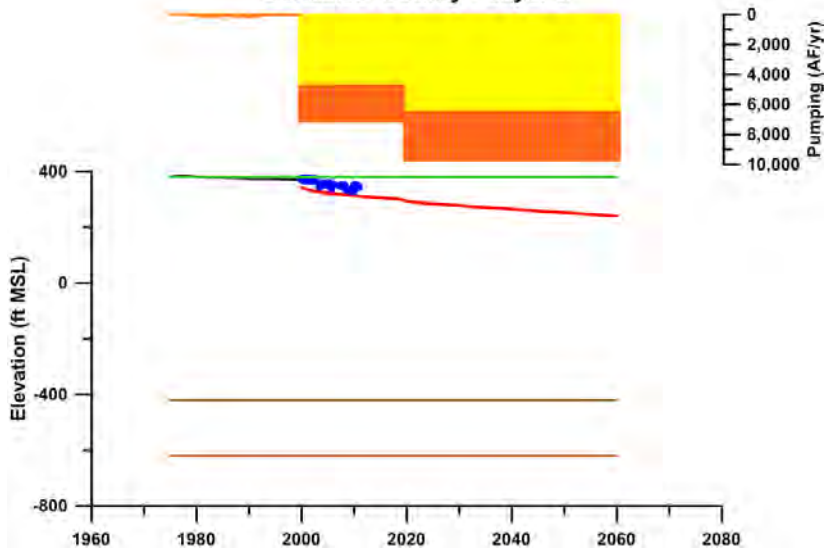

**Well 6743805
Gonzales County - Layer 5**

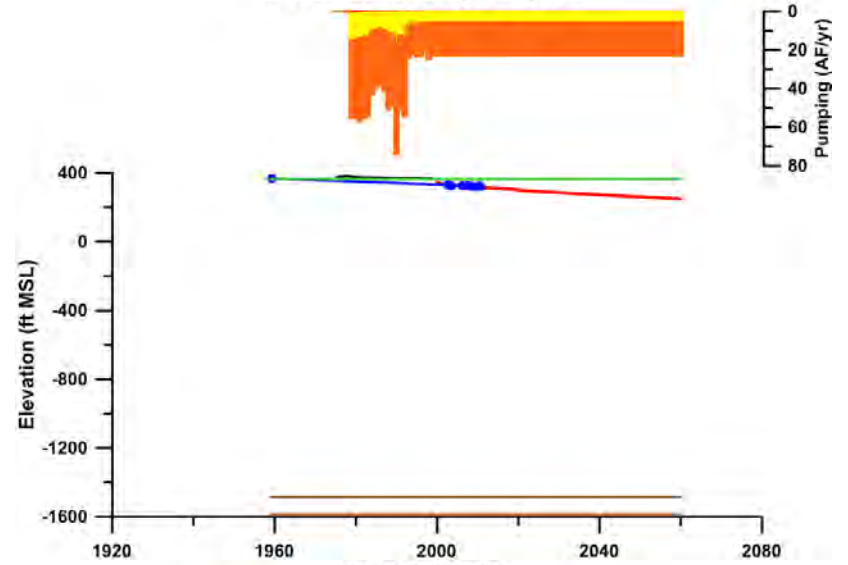

**Well 6743903
Gonzales County - Layer 5**

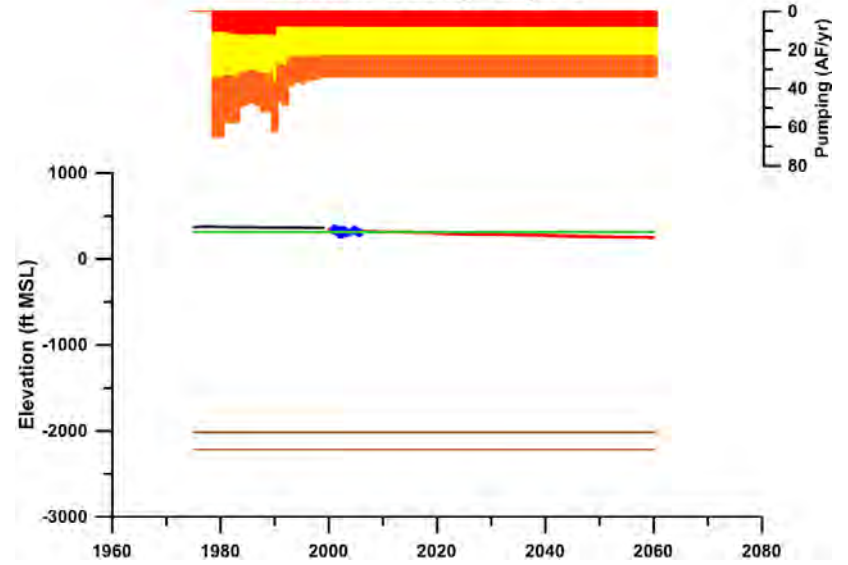

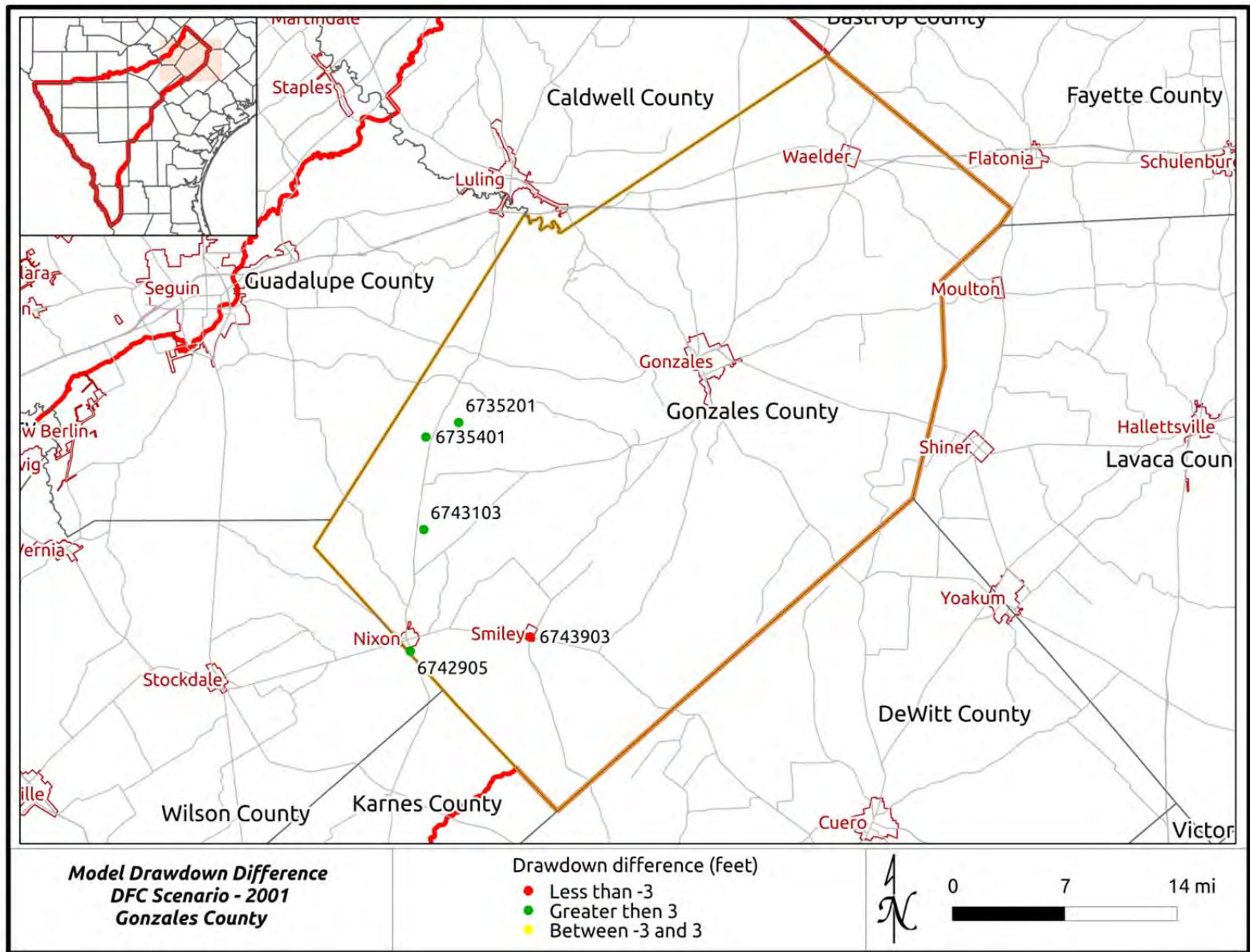

Summary of Drawdown Comparisons - Gonzales County

<i>Column 1</i>	<i>Column 2</i>	<i>Column 3</i>	<i>Column 4</i>	<i>Column 5</i>	<i>Column 6</i>	<i>Column 7</i>
Year	Precipitation (% Avg)	County-Wide Average DFC	Number of Actual Drawdown Data Points	Average Actual Drawdown for Wells with Data	Average DFC for Wells with Data	Column 6 minus Column 5
2000	90	4.72	2	0.10	24.52	24.43
2001	101	8.11	5	13.70	26.59	12.89
2002	113	10.8				
2003	96	13.06	4	10.41	33.43	23.02
2004	132	15.04	4	9.86	36.14	26.28
2005	75	16.82	4	12.71	38.52	25.81
2006	86	18.43				
2007	142	19.91	4	12.71	42.61	29.91
2008	74	21.29				
2009	76	22.58	4	16.35	46.21	29.86
2010	132	23.77				
2011	45	24.91				

Gonzales County - All Years

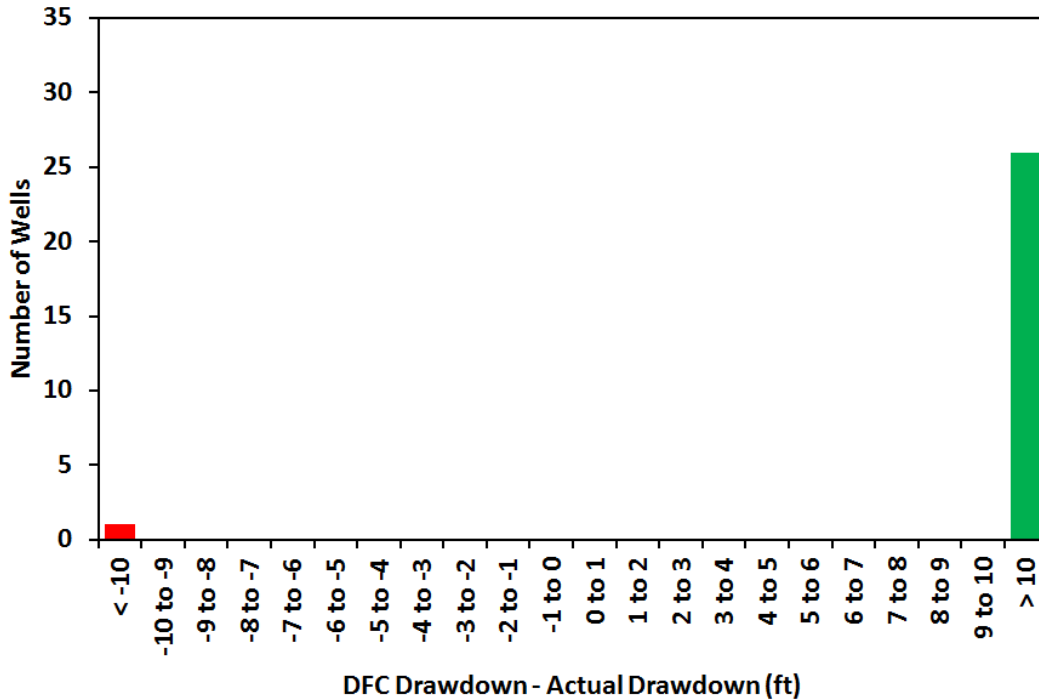

Gonzales County

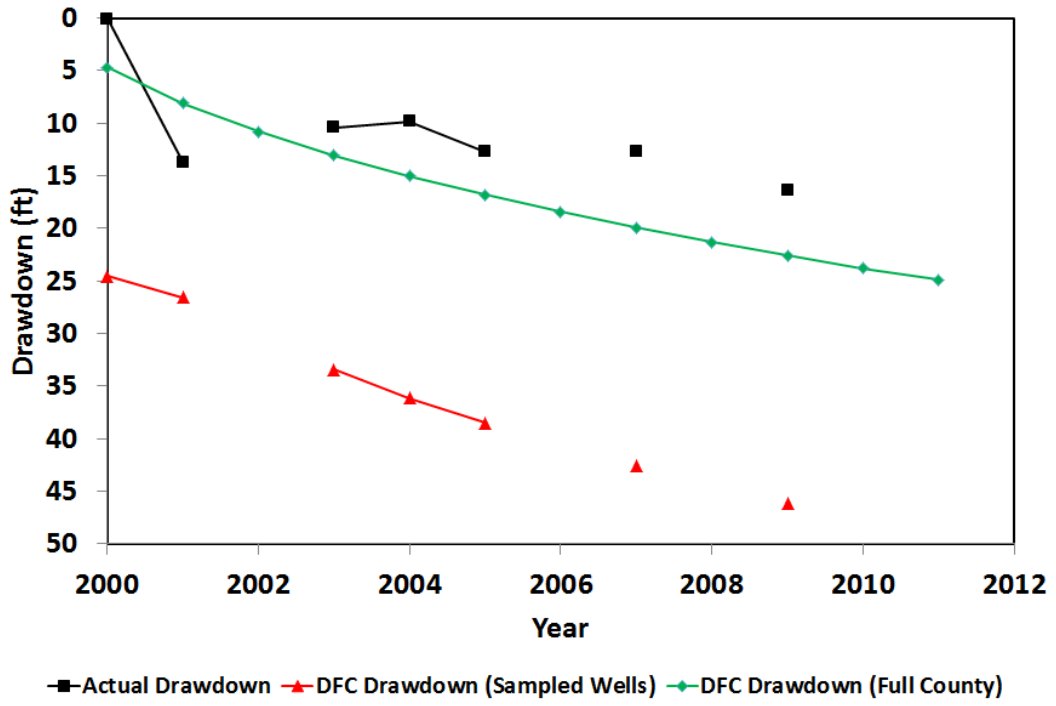

Appendix 8 – Guadalupe County

Location Map of Hydrograph Wells

Hydrographs

Note that pumping data are expressed in three zones:

- Pump 1 = pumping from cell where well is located
- Pump 2 = pumping in cells adjacent to Zone 1
- Pump 3 = pumping in cells adjacent to Zone 2

Screen Bottom and Screen Top = Elevation of Well Completion Interval

Land Surface = Elevation of Land Surface at Well

Groundwater Elevations

- Measured = Actual data from TWDB database
- Calibrated Model = Results for cell defined by well from calibrated model
- DFC = Results for cell defined by well from Scenario 4 of GAM Run 09-034

Drawdown Comparison Maps for 2001, 2006 and 2011

Summary of Drawdown Comparisons

Table analogous to Table 5 in text summarizing annual average drawdown (actual and DFC)

Histogram of Differences between DFC Drawdown and Actual Drawdown for All Years

Figure analogous to Figure 23 in text showing differences between actual drawdown and DFC conditions

Hydrograph of Actual Drawdown and DFC Drawdown

Figure analogous to Figure 26 in text showing time history of drawdown (actual and DFC) from 2000 to 2011

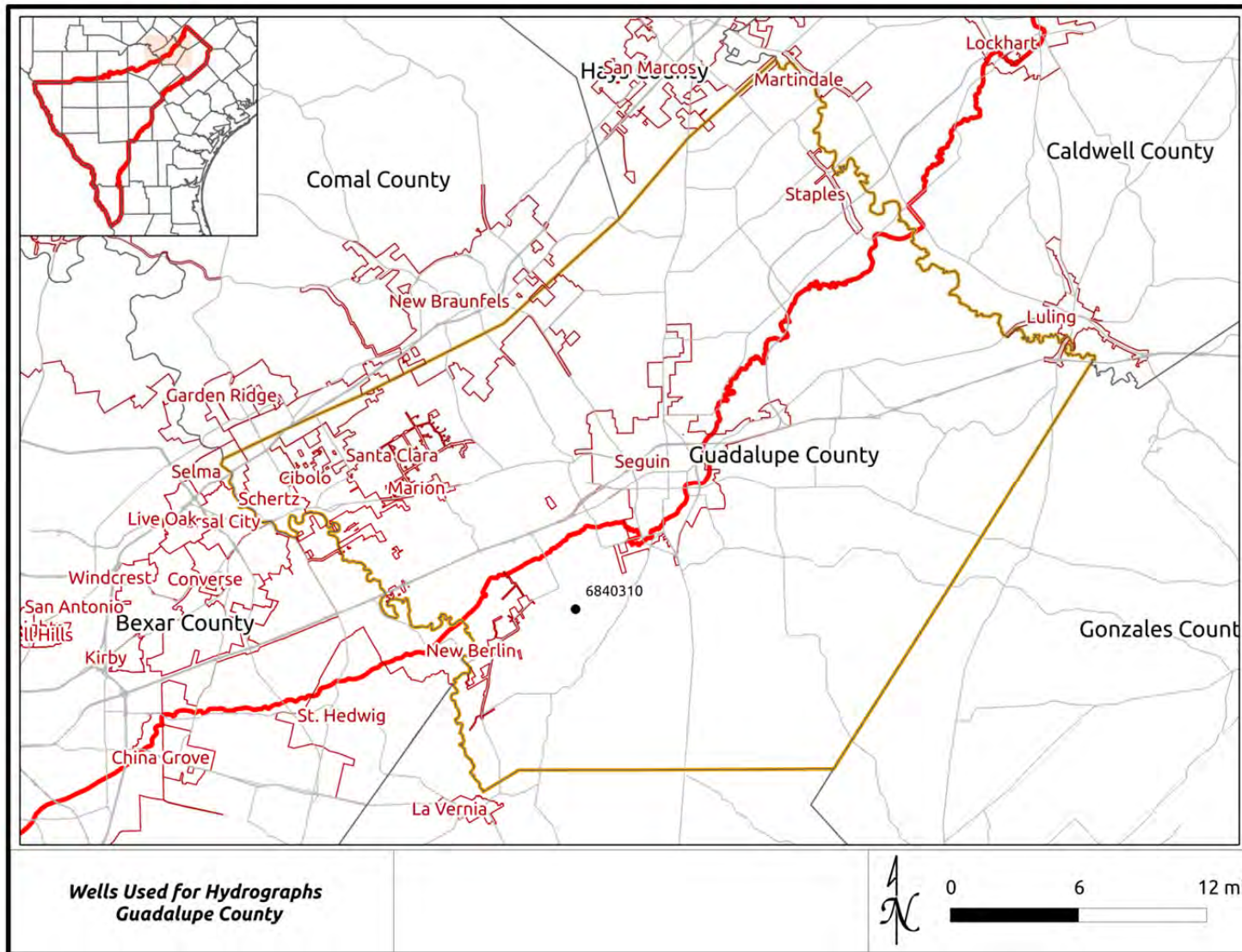

Location Map of Wells with Hydrographs – Guadalupe County

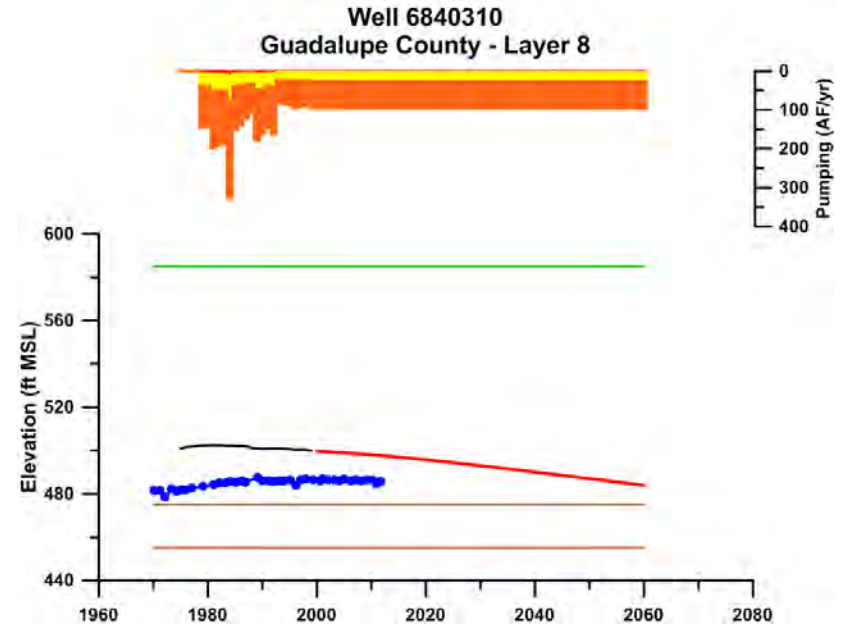
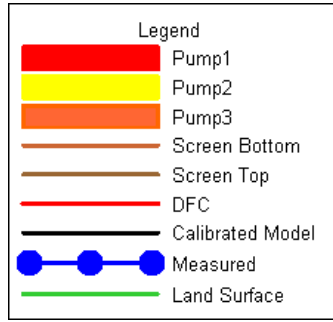

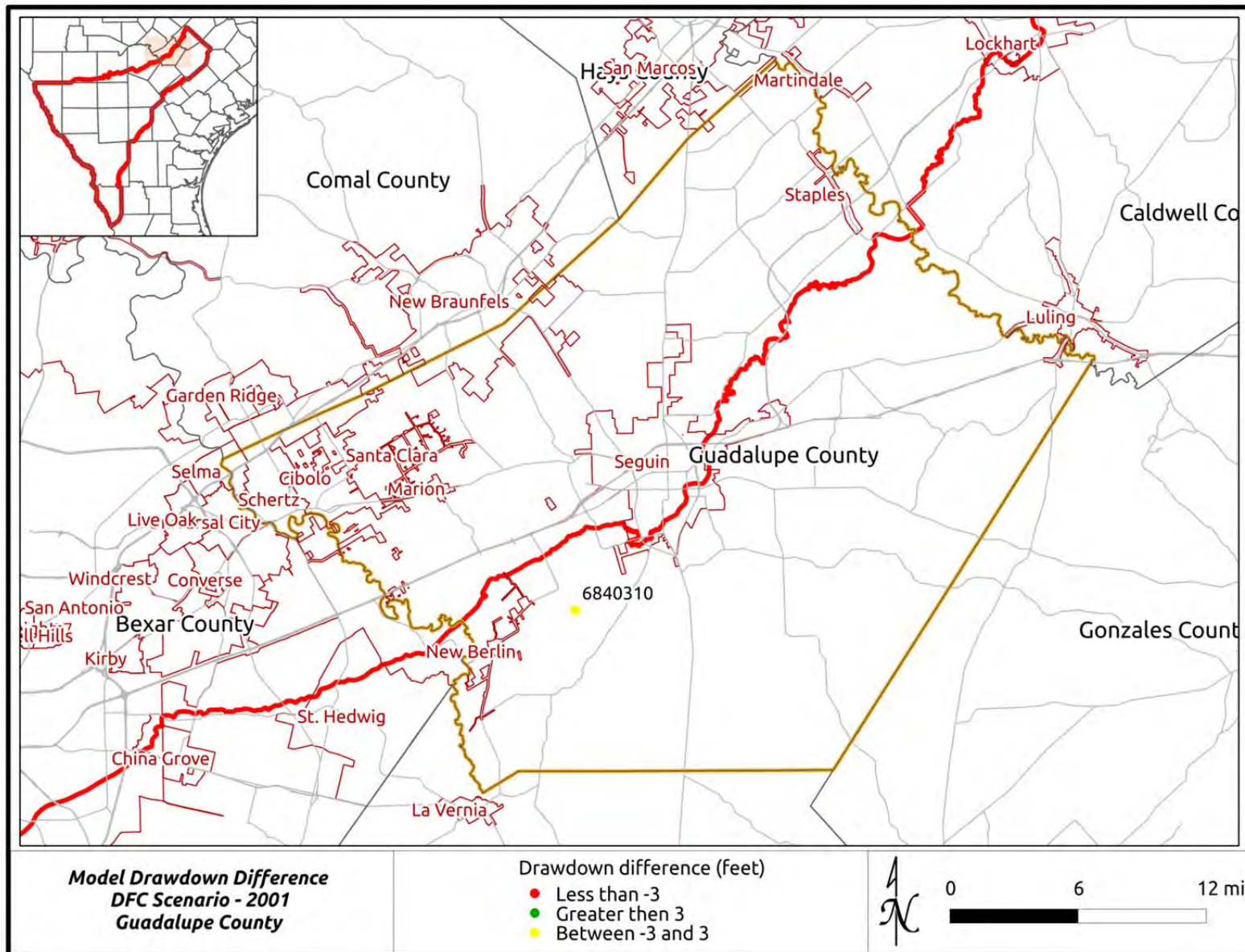

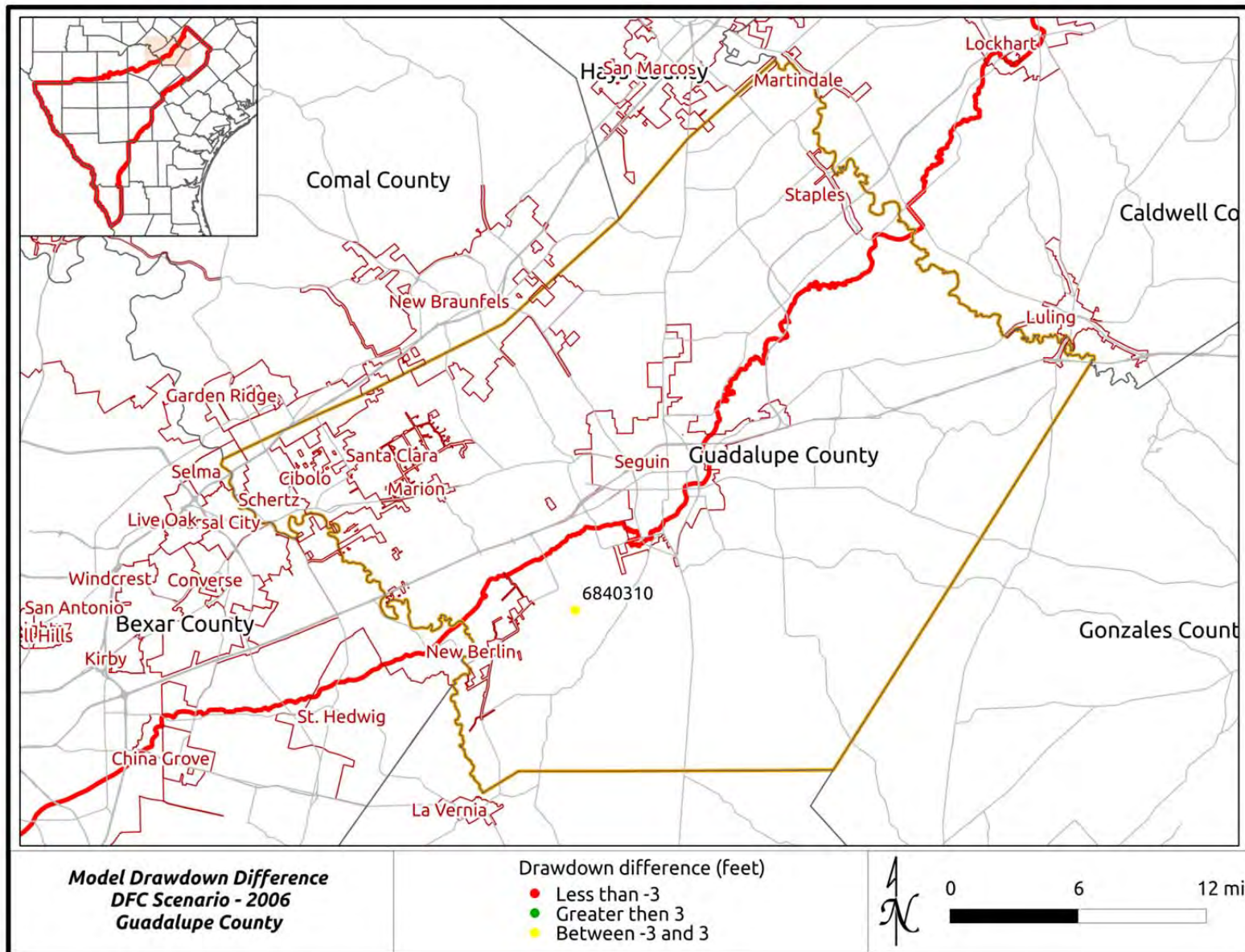

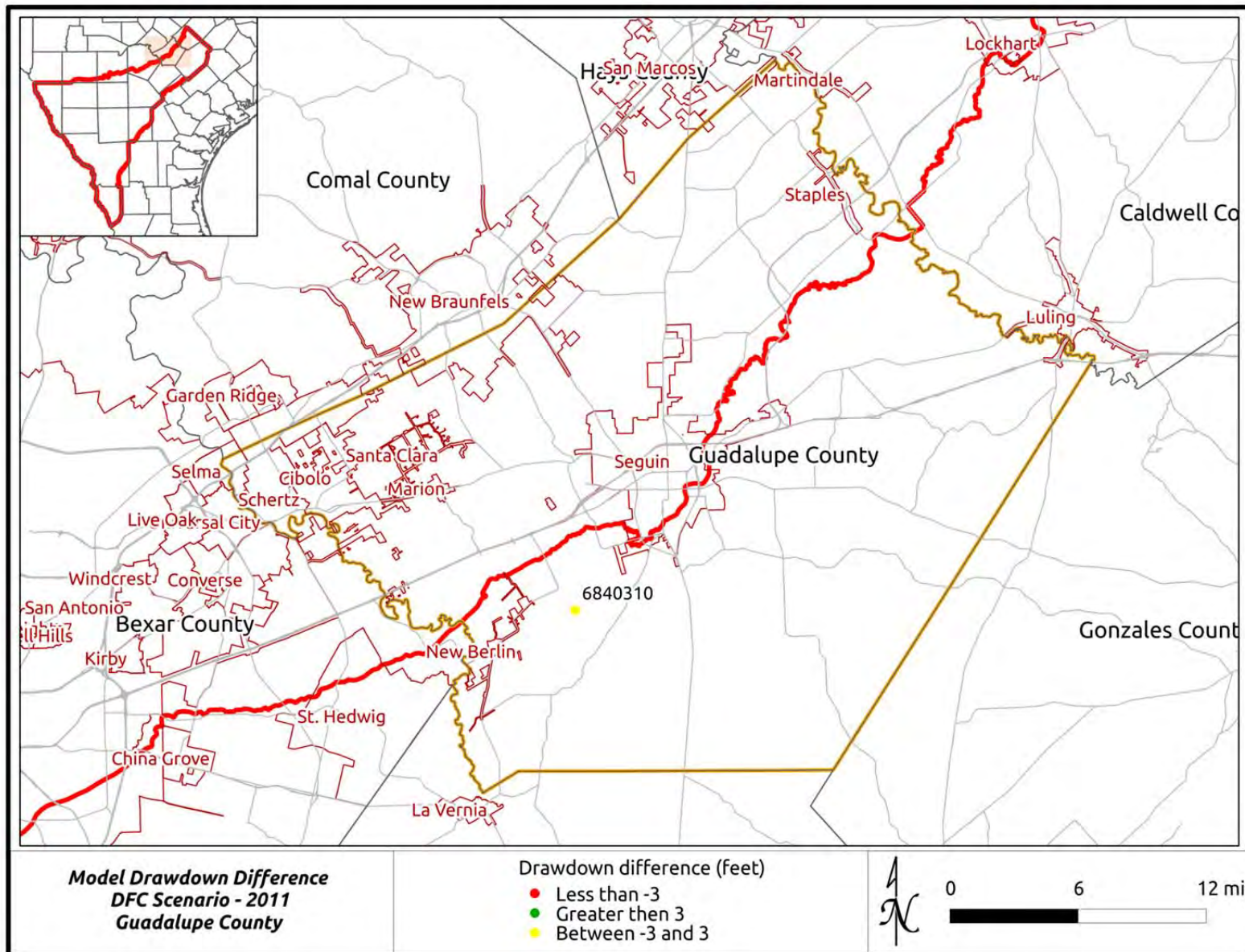

Summary of Drawdown Comparisons - Guadalupe County

<i>Column 1</i>	<i>Column 2</i>	<i>Column 3</i>	<i>Column 4</i>	<i>Column 5</i>	<i>Column 6</i>	<i>Column 7</i>
Year	Precipitation (% Avg)	County-Wide Average DFC	Number of Actual Drawdown Data Points	Average Actual Drawdown for Wells with Data	Average DFC for Wells with Data	Column 6 minus Column 5
2000	90	0.76	1	-0.65	0.18	0.83
2001	101	1.61	1	-0.3	0.35	0.65
2002	113	2.46	1	-0.52	0.51	1.03
2003	96	3.26	1	0	0.67	0.67
2004	132	4.04	1	-0.82	0.84	1.66
2005	75	4.77	1	0	1	1
2006	86	5.49	1	-0.62	1.17	1.79
2007	142	6.16	1	-0.15	1.34	1.49
2008	74	6.83	1	-0.3	1.52	1.82
2009	76	7.48				
2010	132	8.12	1	1.36	1.9	0.54
2011	45	8.76	1	0.41	2.1	1.69

Guadalupe County - All Years

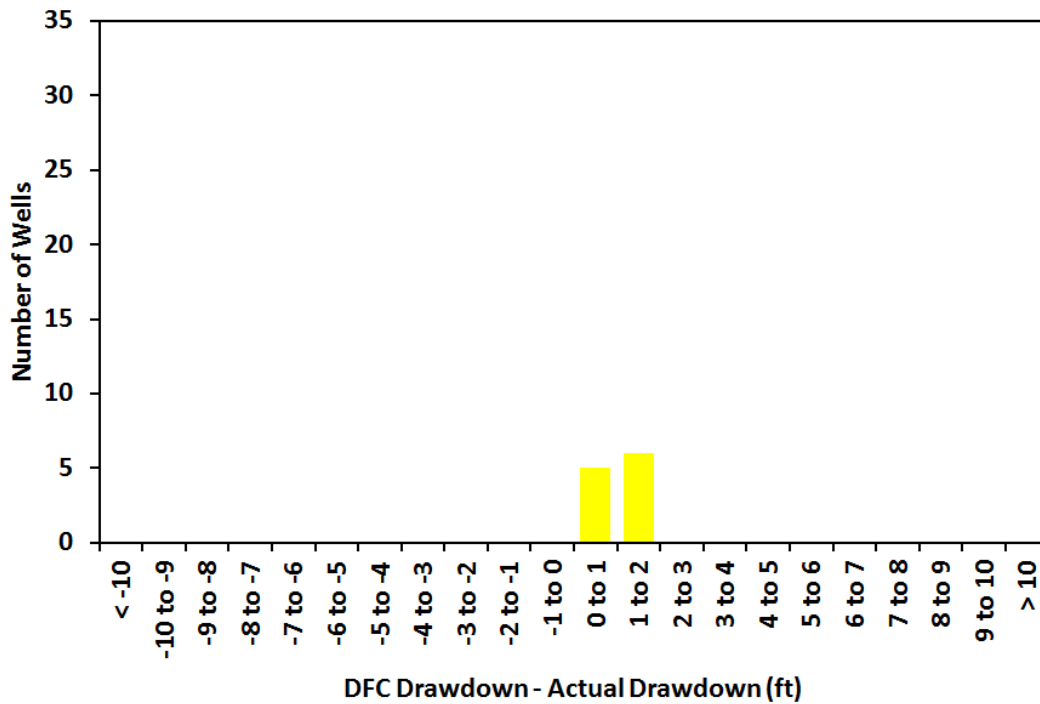

Guadalupe County

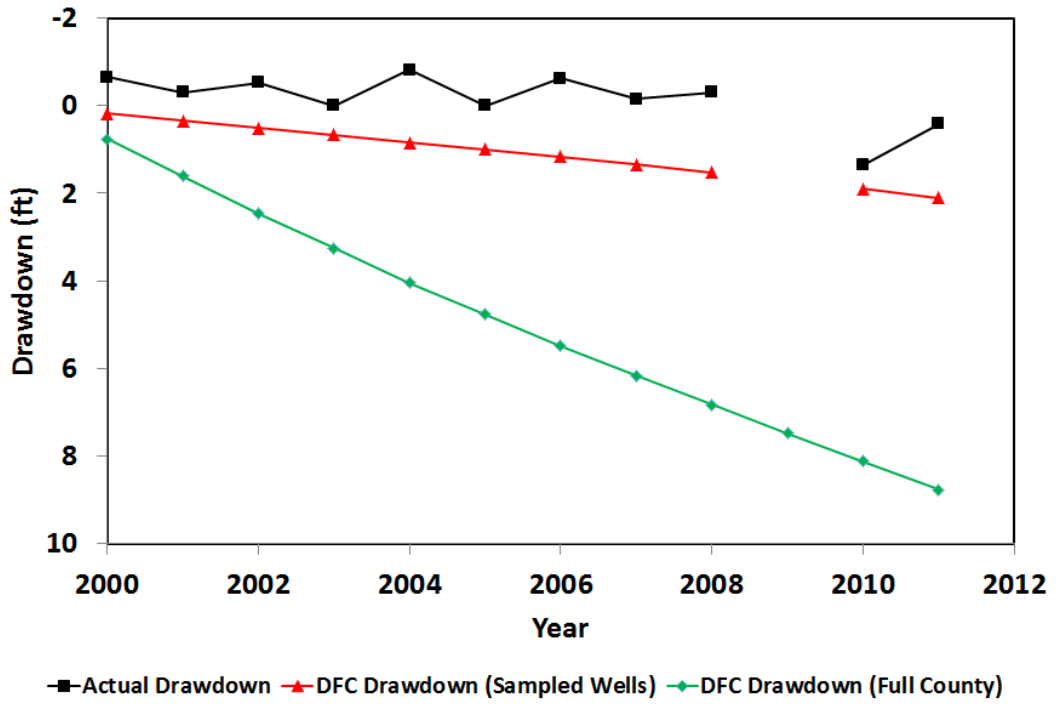

Appendix 9 – La Salle County

Location Map of Hydrograph Wells

Hydrographs

Note that pumping data are expressed in three zones:

- Pump 1 = pumping from cell where well is located
- Pump 2 = pumping in cells adjacent to Zone 1
- Pump 3 = pumping in cells adjacent to Zone 2

Screen Bottom and Screen Top = Elevation of Well Completion Interval

Land Surface = Elevation of Land Surface at Well

Groundwater Elevations

- Measured = Actual data from TWDB database
- Calibrated Model = Results for cell defined by well from calibrated model
- DFC = Results for cell defined by well from Scenario 4 of GAM Run 09-034

Drawdown Comparison Maps for 2001, 2006 and 2011

Summary of Drawdown Comparisons

Table analogous to Table 5 in text summarizing annual average drawdown (actual and DFC)

Histogram of Differences between DFC Drawdown and Actual Drawdown for All Years

Figure analogous to Figure 23 in text showing differences between actual drawdown and DFC conditions

Hydrograph of Actual Drawdown and DFC Drawdown

Figure analogous to Figure 26 in text showing time history of drawdown (actual and DFC) from 2000 to 2011

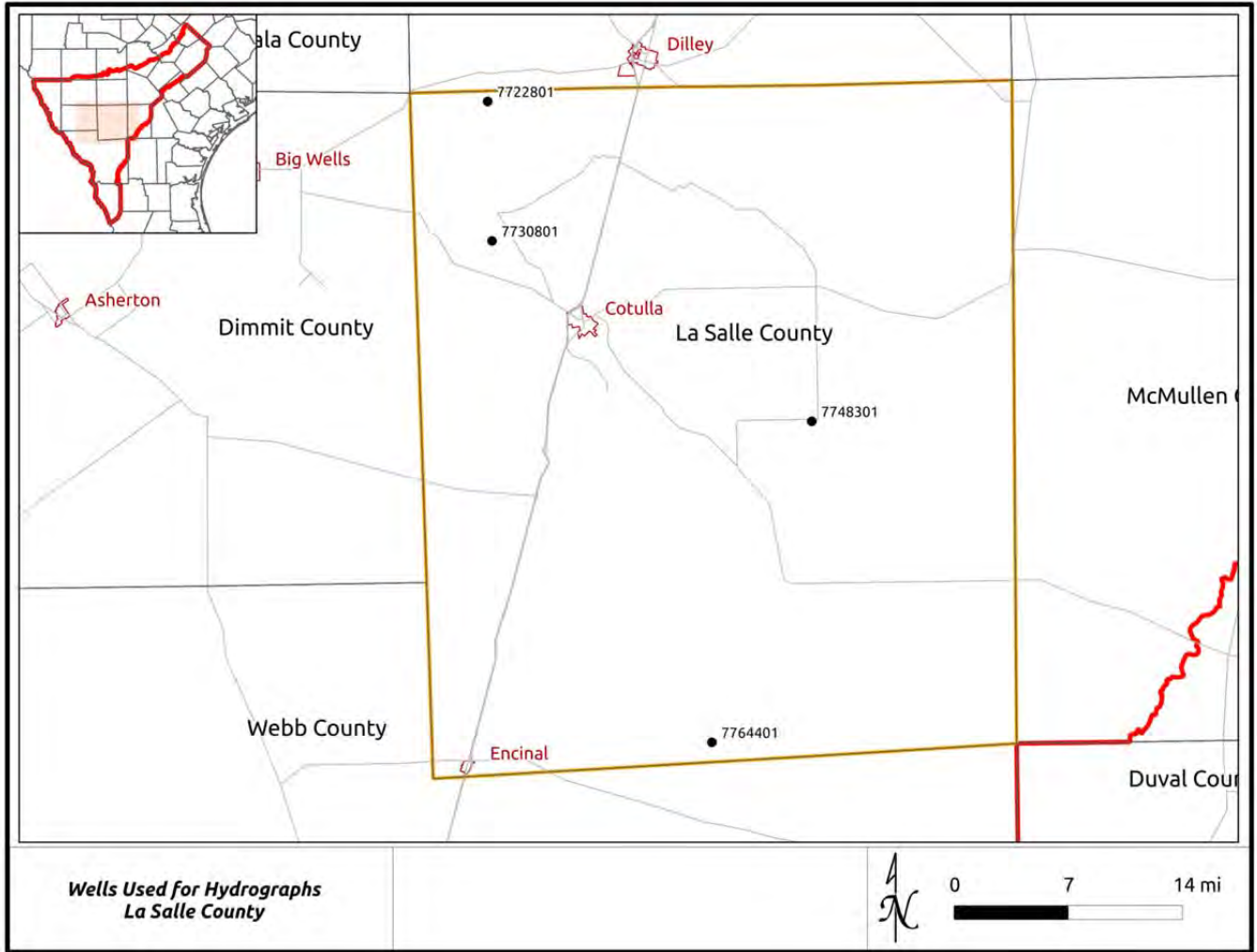

Location Map of Wells with Hydrographs – La Salle County

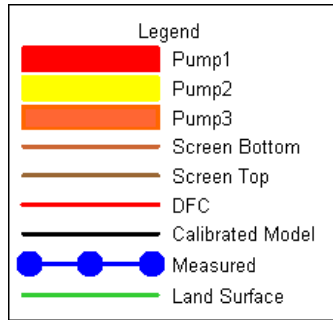

Well 7722801
LaSalle County - Layer 1

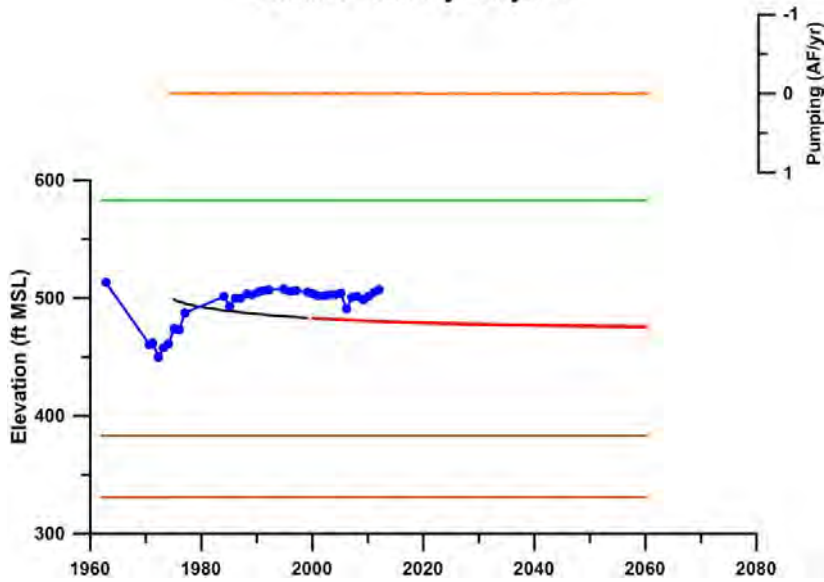

Well 7730801
LaSalle County - Layer 5

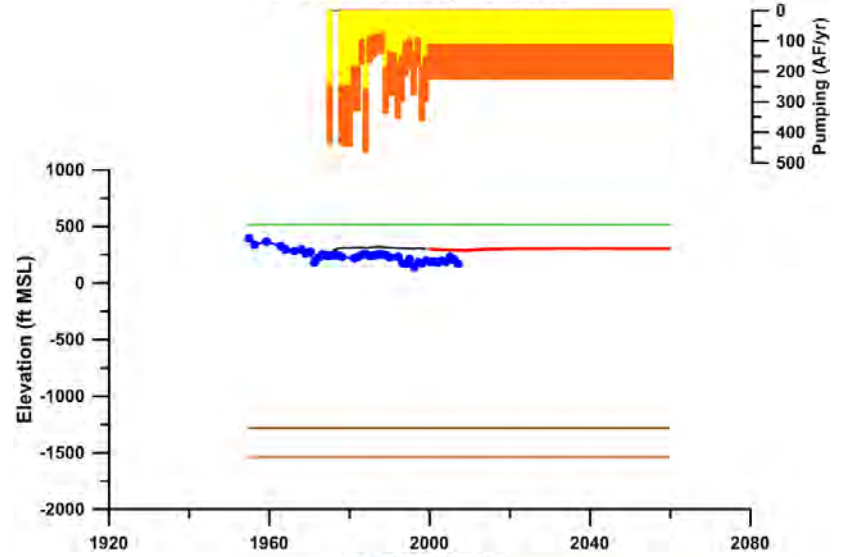

Well 7748301
LaSalle County - Layer 5

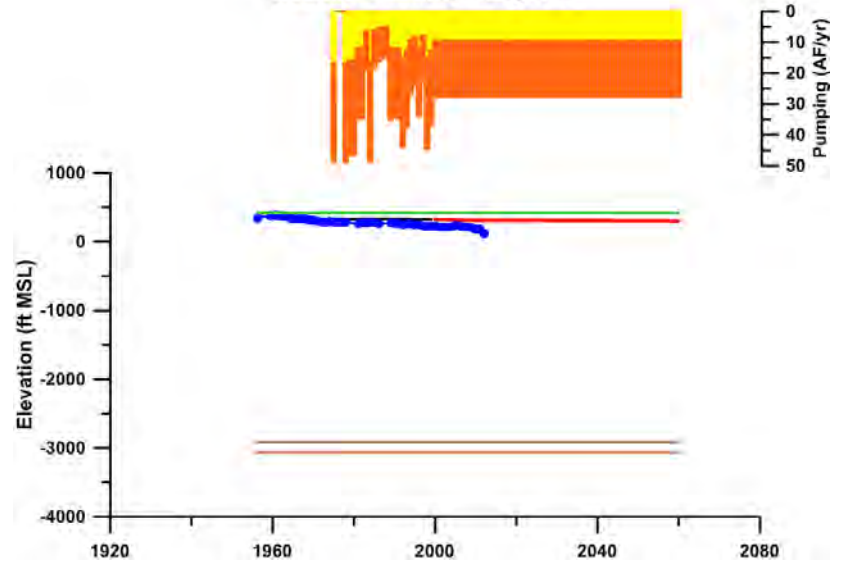

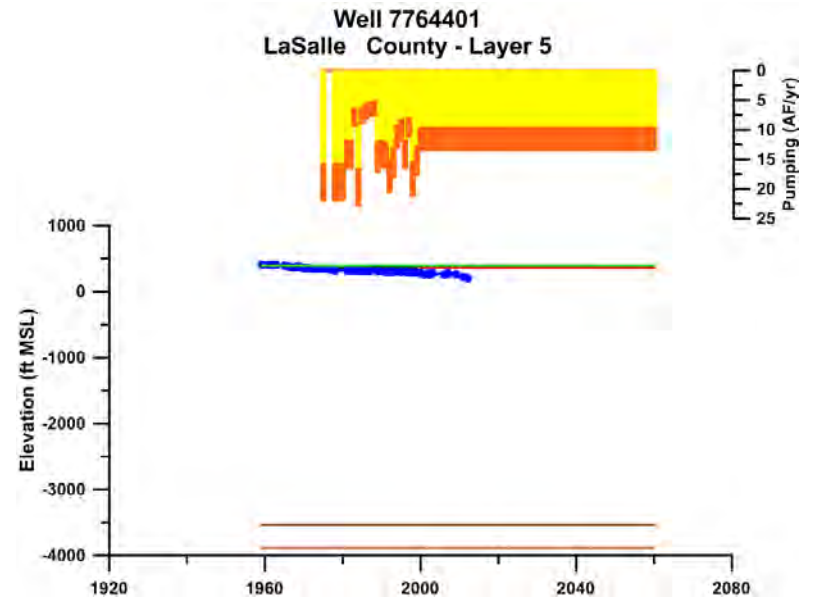
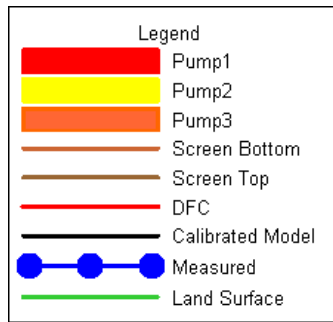

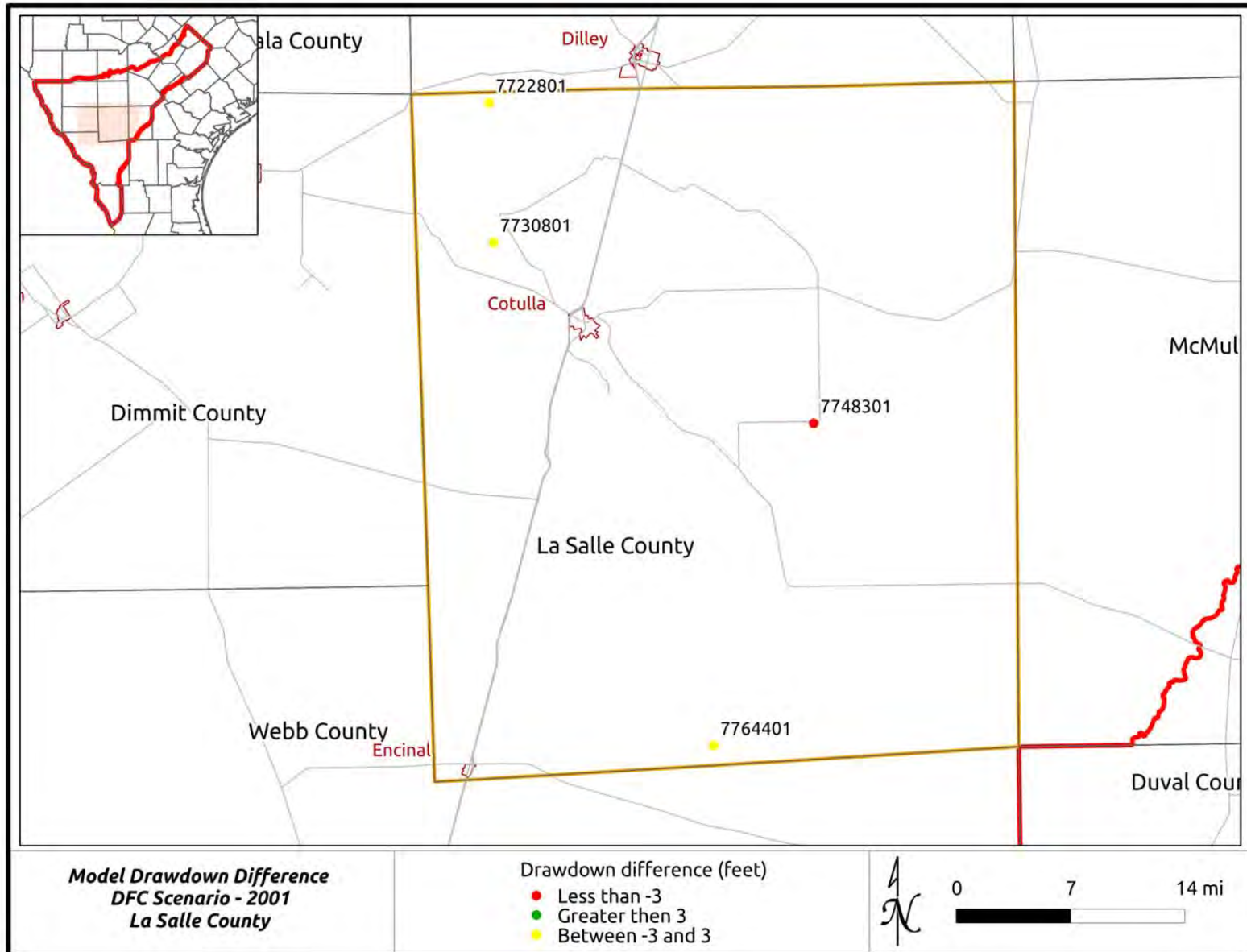

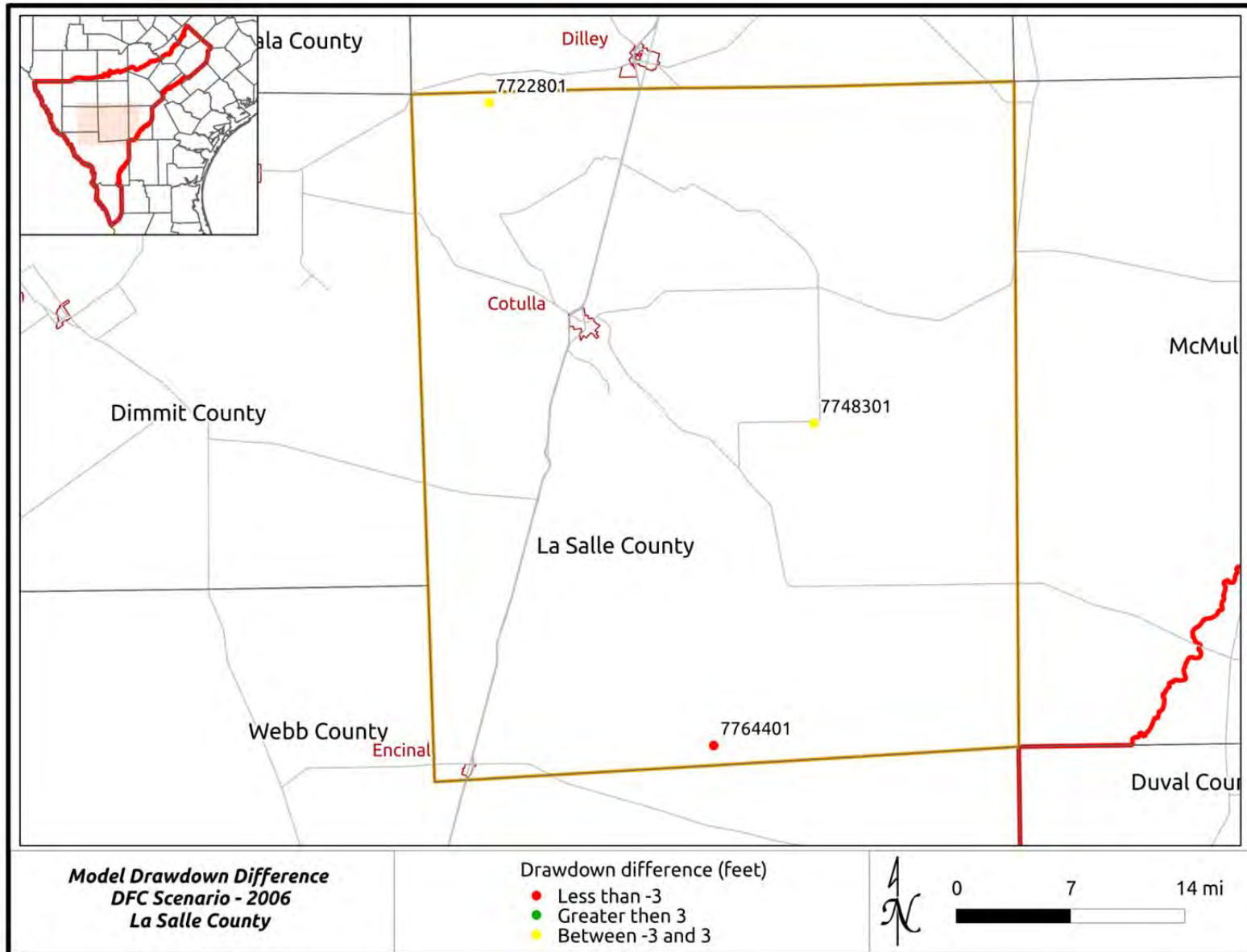

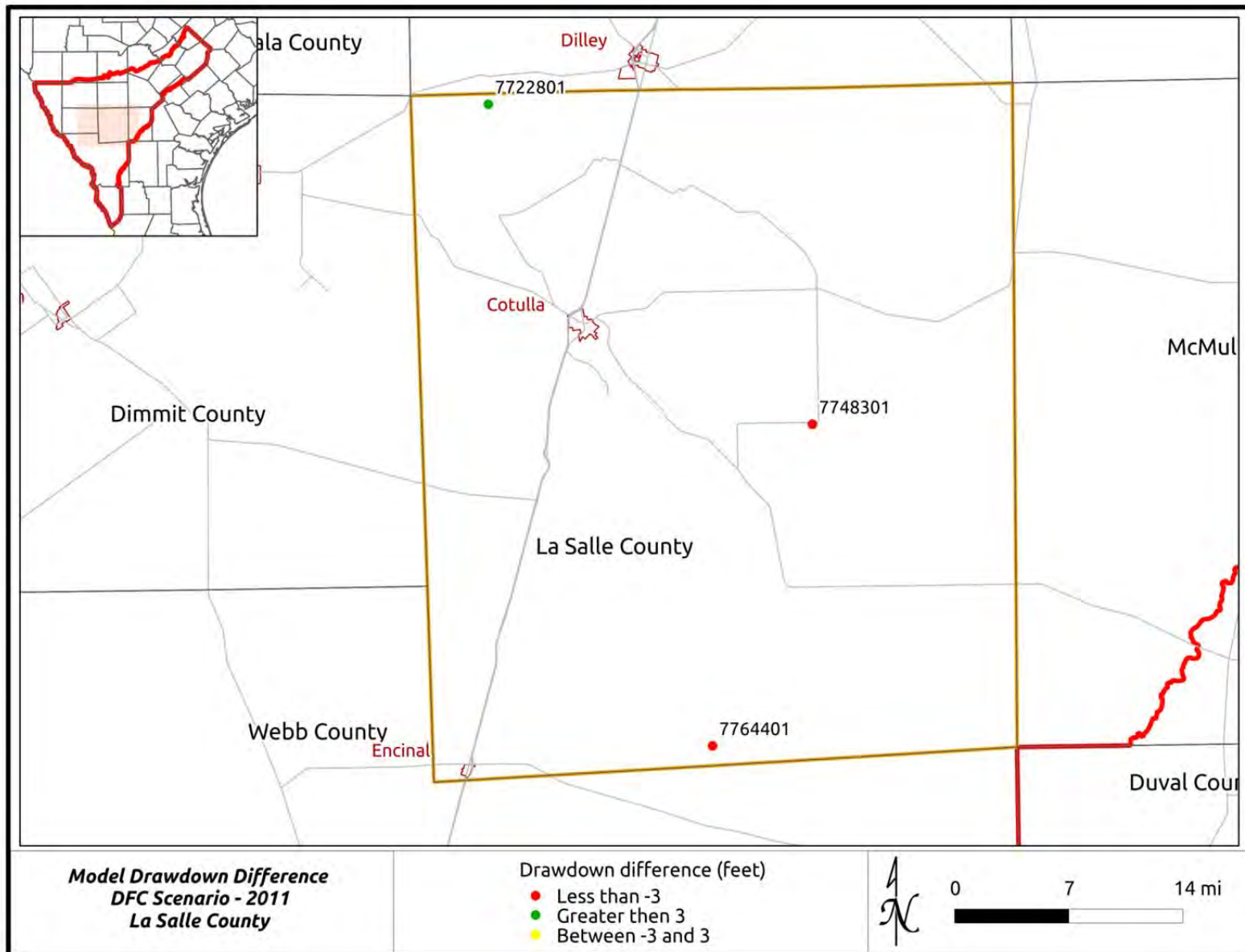

Summary of Drawdown Comparisons - La Salle County

<i>Column 1</i>	<i>Column 2</i>	<i>Column 3</i>	<i>Column 4</i>	<i>Column 5</i>	<i>Column 6</i>	<i>Column 7</i>
Year	Precipitation (% Avg)	County-Wide Average DFC	Number of Actual Drawdown Data Points	Average Actual Drawdown for Wells with Data	Average DFC for Wells with Data	Column 6 minus Column 5
2000	90	0.53	4	6.84	0.65	-6.19
2001	101	1.14	4	3.35	1.74	-1.61
2002	113	1.71	4	2.19	2.77	0.59
2003	96	2.23	3	1.80	4.91	3.11
2004	132	2.71	2	-7.74	3.97	11.71
2005	75	3.16	3	5.61	3.27	-2.33
2006	86	3.57	3	6.88	3.82	-3.07
2007	142	3.97	2	6.65	6.15	-0.51
2008	74	4.35	3	11.87	4.84	-7.03
2009	76	4.71	2	20.28	7.39	-12.89
2010	132	4.63	3	34.02	5.74	-28.28
2011	45	4.42	3	56.80	5.98	-50.82

La Salle County - All Years

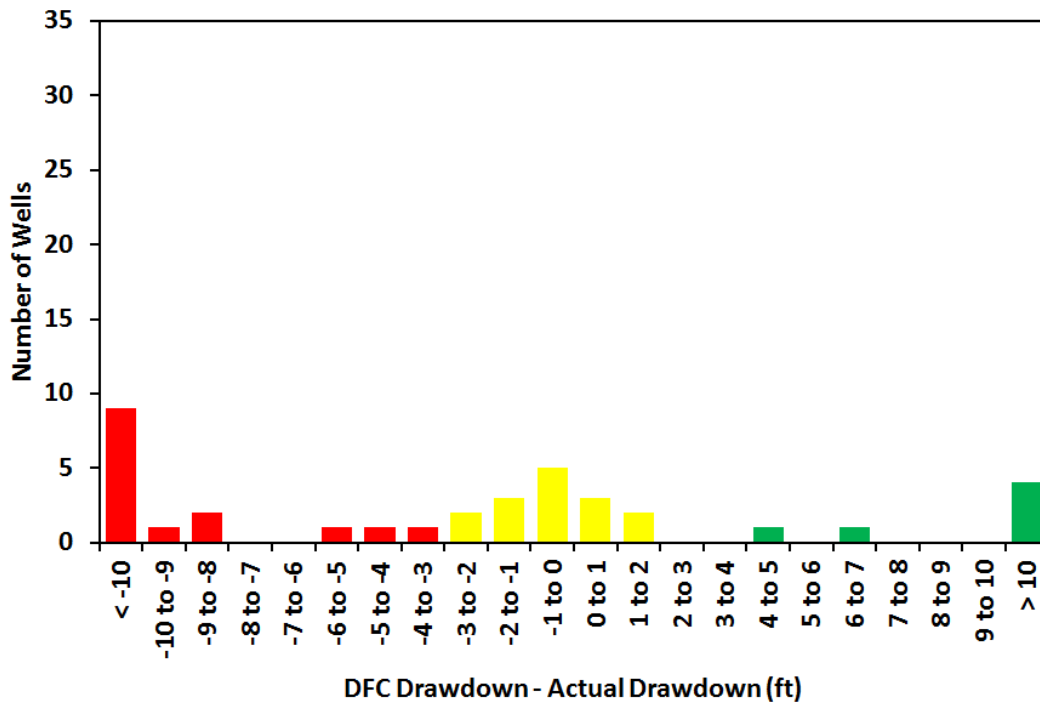

La Salle County

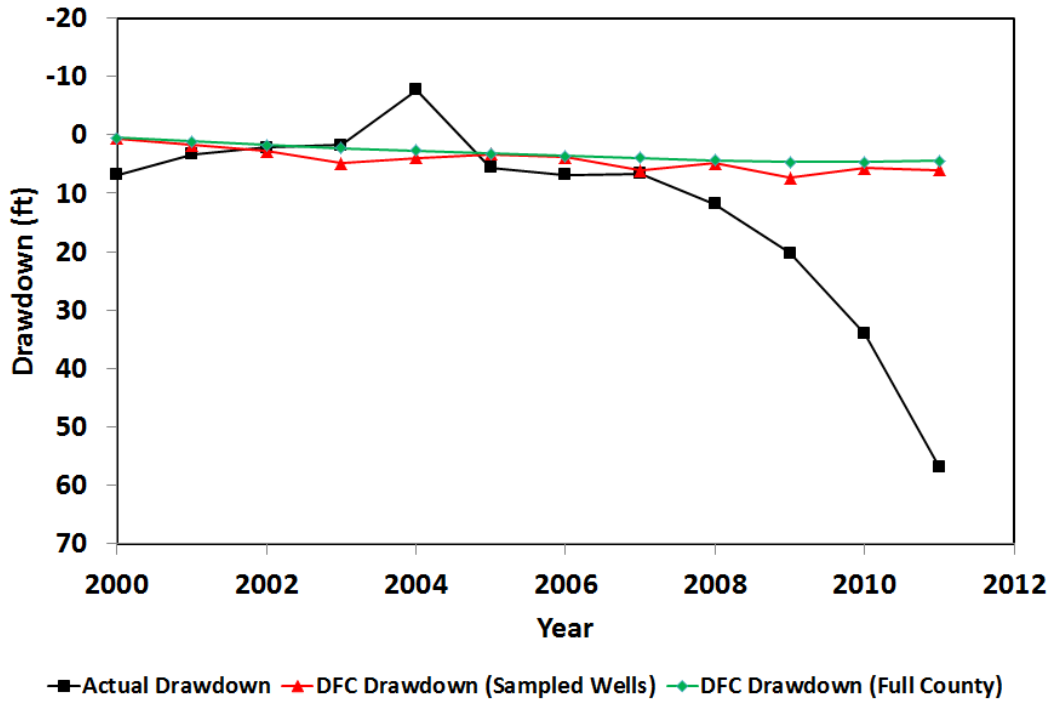

Appendix 10 – Maverick County

Location Map of Hydrograph Wells

Hydrographs

Note that pumping data are expressed in three zones:

- Pump 1 = pumping from cell where well is located
- Pump 2 = pumping in cells adjacent to Zone 1
- Pump 3 = pumping in cells adjacent to Zone 2

Screen Bottom and Screen Top = Elevation of Well Completion Interval

Land Surface = Elevation of Land Surface at Well

Groundwater Elevations

- Measured = Actual data from TWDB database
- Calibrated Model = Results for cell defined by well from calibrated model
- DFC = Results for cell defined by well from Scenario 4 of GAM Run 09-034

Drawdown Comparison Maps for 2001, 2006 and 2011

Summary of Drawdown Comparisons

Table analogous to Table 5 in text summarizing annual average drawdown (actual and DFC)

Histogram of Differences between DFC Drawdown and Actual Drawdown for All Years

Figure analogous to Figure 23 in text showing differences between actual drawdown and DFC conditions

Hydrograph of Actual Drawdown and DFC Drawdown

Figure analogous to Figure 26 in text showing time history of drawdown (actual and DFC) from 2000 to 2011

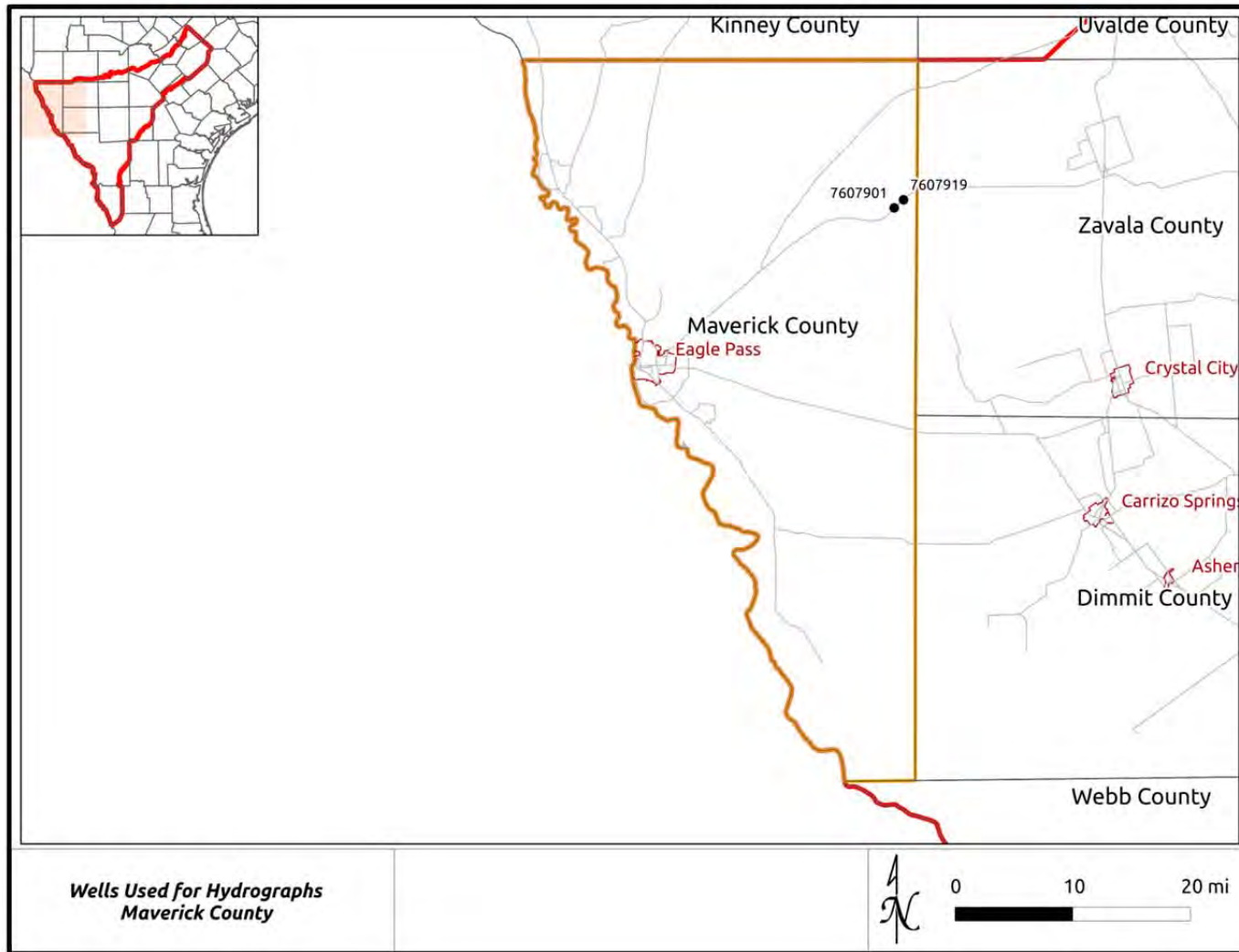

Location Map of Wells with Hydrographs – Maverick County

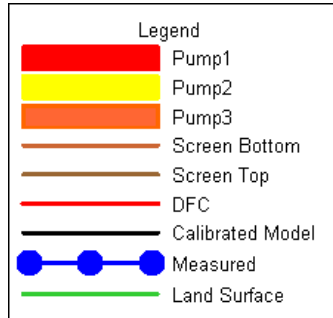

**Well 7607901
Maverick County - Layer 5**

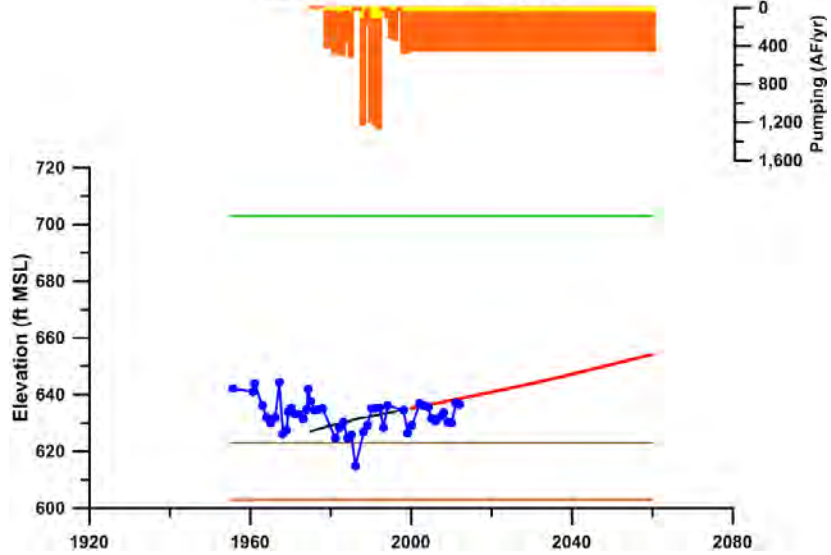

**Well 7607919
Maverick County - Layer 5**

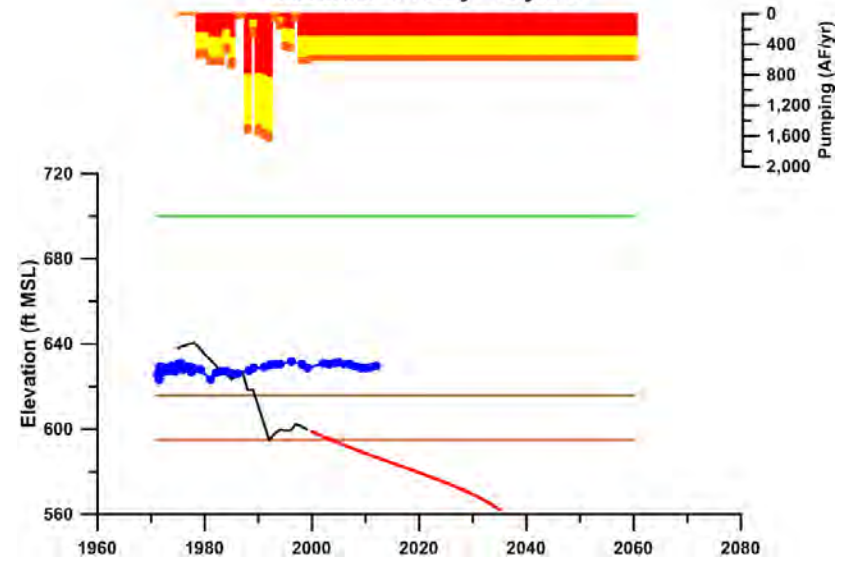

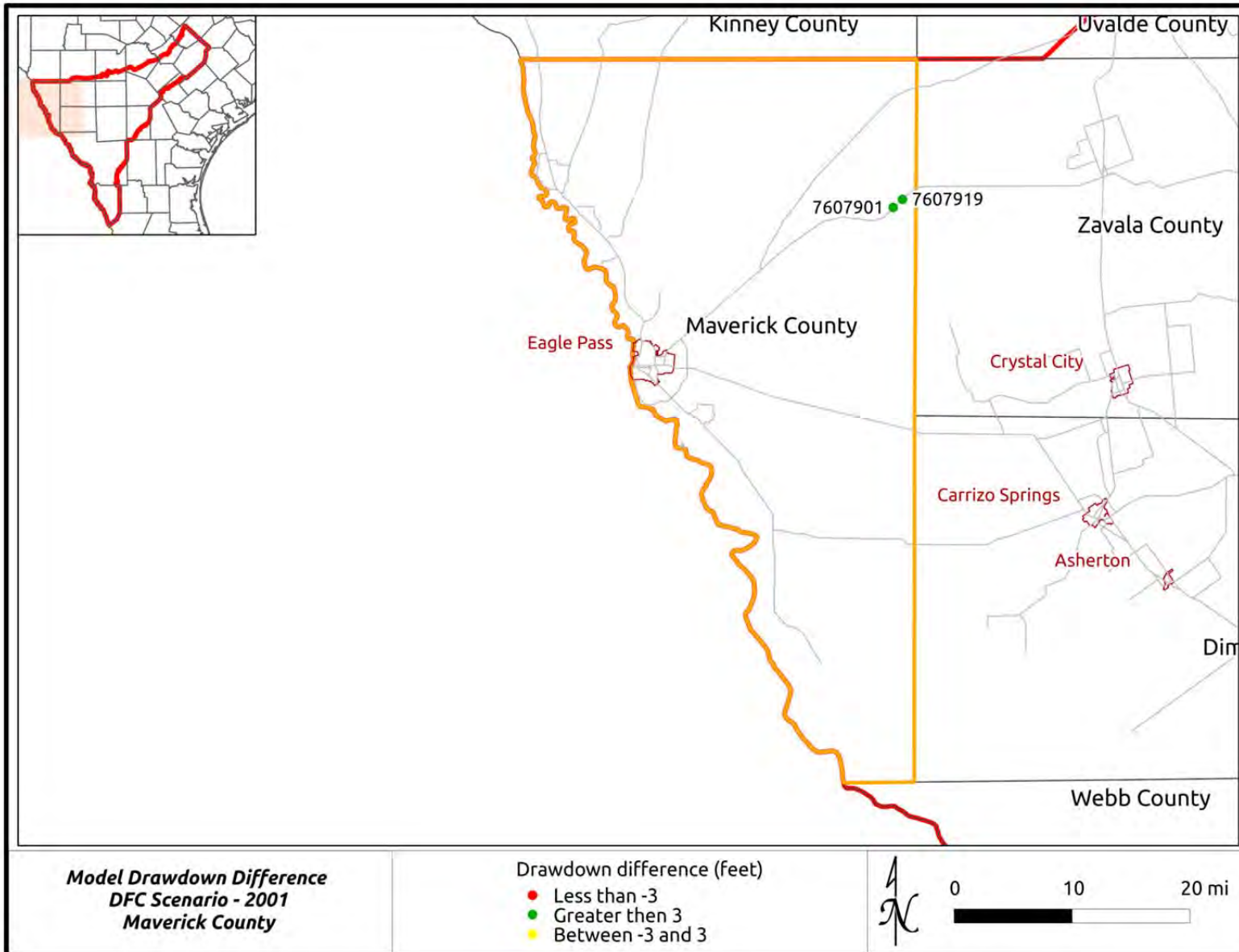

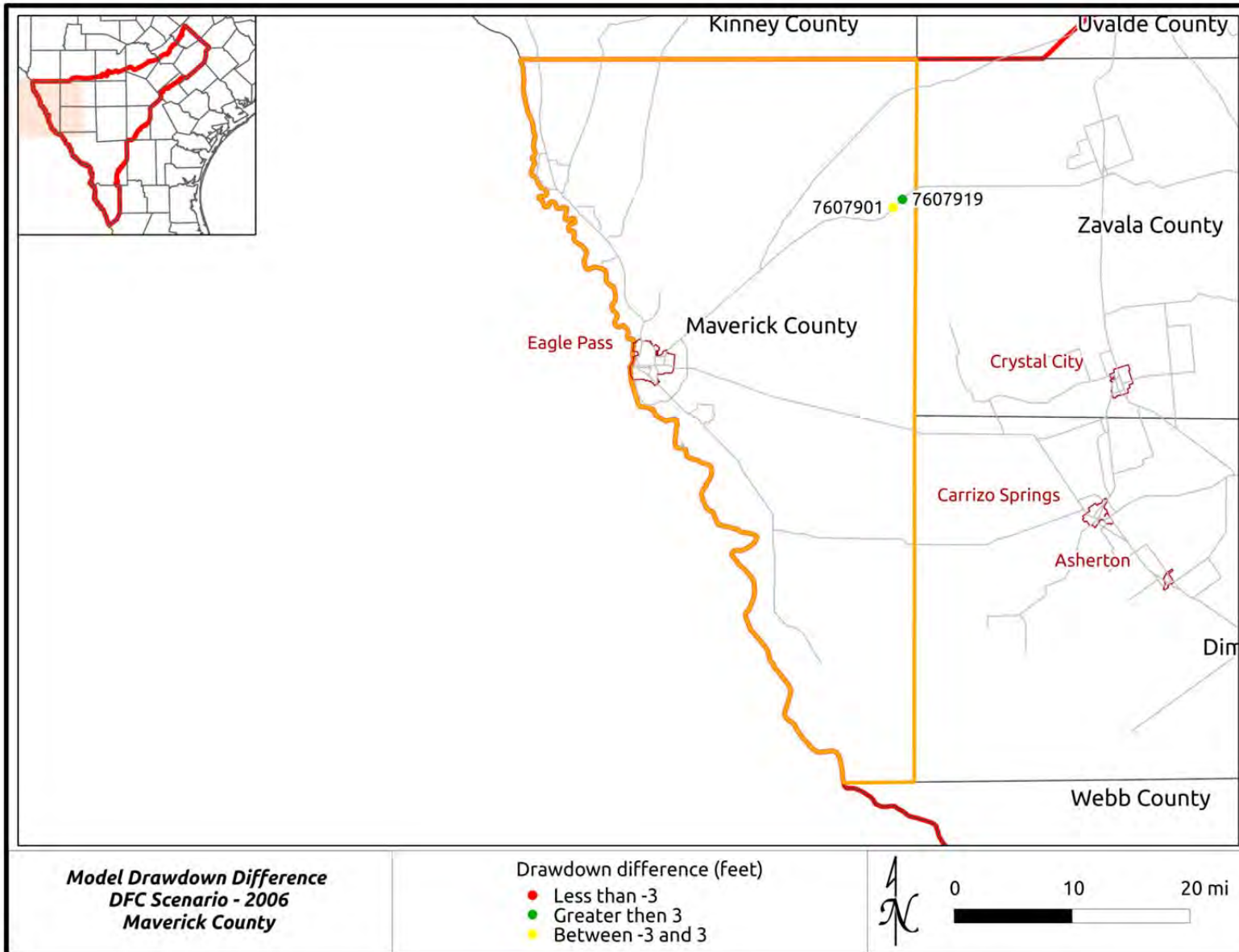

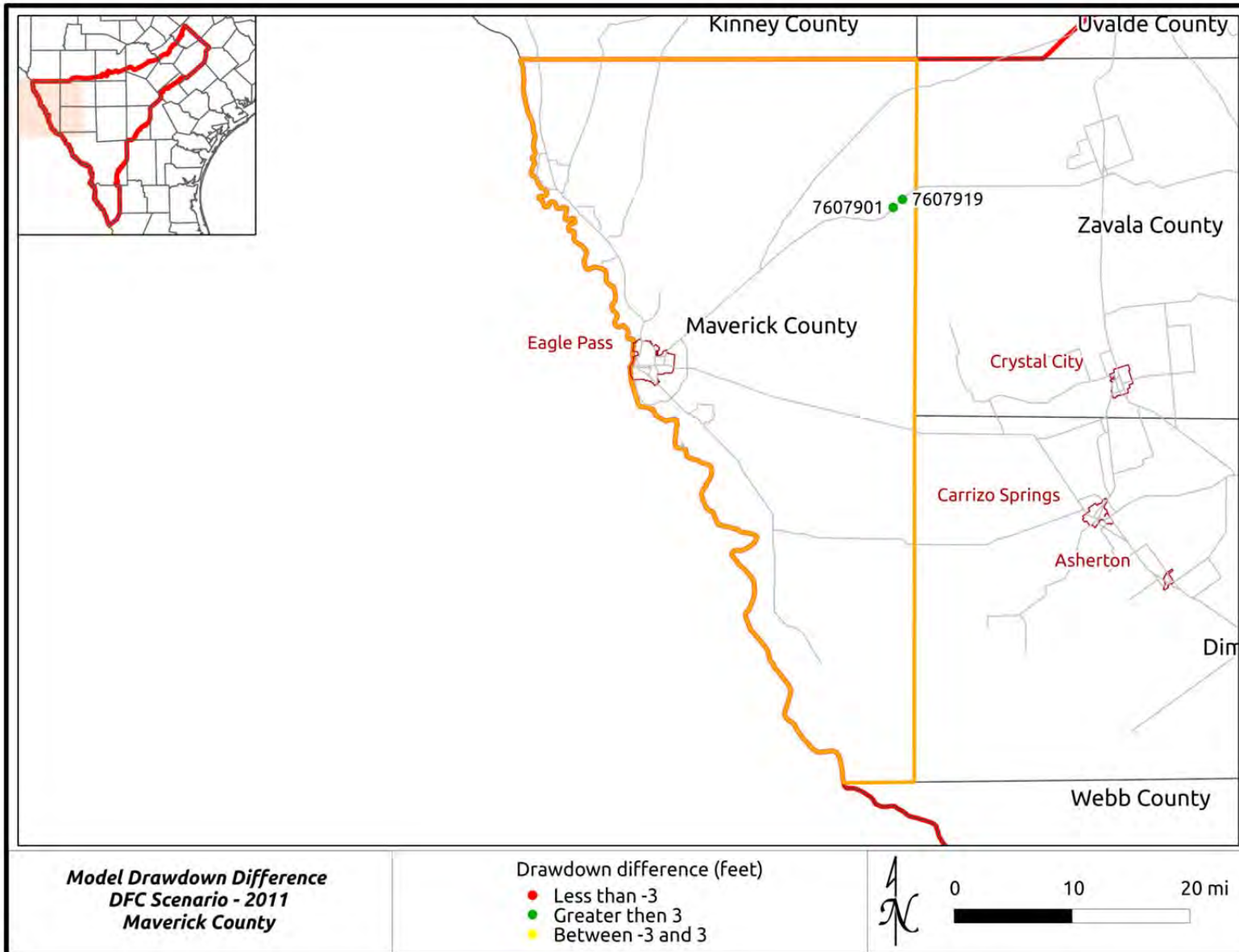

Summary of Drawdown Comparisons - Maverick County

<i>Column 1</i>	<i>Column 2</i>	<i>Column 3</i>	<i>Column 4</i>	<i>Column 5</i>	<i>Column 6</i>	<i>Column 7</i>
Year	Precipitation (% Avg)	County-Wide Average DFC	Number of Actual Drawdown Data Points	Average Actual Drawdown for Wells with Data	Average DFC for Wells with Data	Column 6 minus Column 5
2000	90	-0.13				
2001	101	-0.26	2	-4.82	0.87	5.69
2002	113	-0.42	2	-4.30	1.28	5.58
2003	96	-0.61	2	-4.20	1.68	5.88
2004	132	-0.74	2	-2.45	2.07	4.52
2005	75	-0.85	2	-1.47	2.45	3.91
2006	86	-1.00	2	-2.38	2.81	5.19
2007	142	-1.32	2	-2.61	3.17	5.78
2008	74	-1.48	2	-0.56	3.51	4.06
2009	76	-1.60	2	-0.34	3.84	4.18
2010	132	-1.72	2	-3.99	4.16	8.15
2011	45	-1.86	2	-4.02	4.49	8.50

Maverick County - All Years

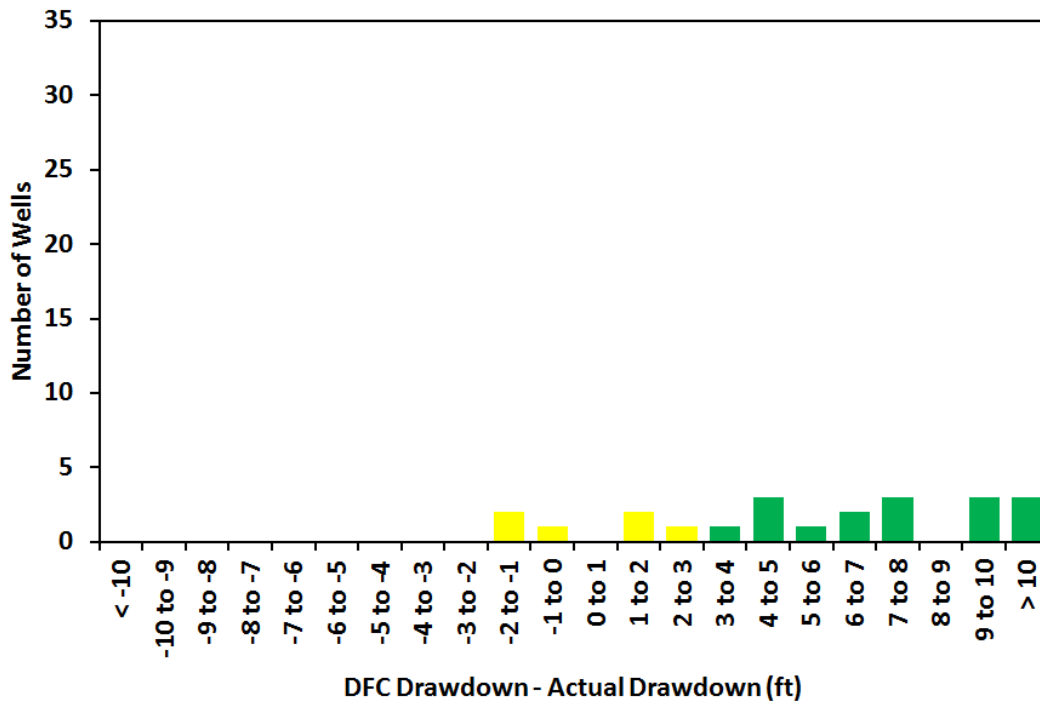

Maverick County

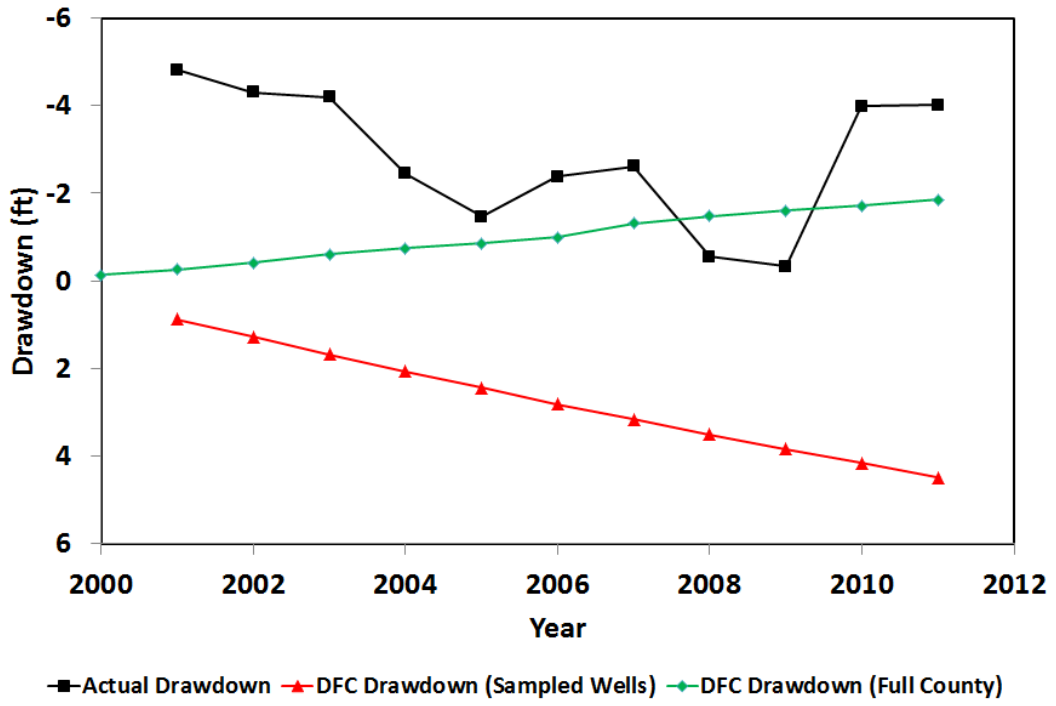

Appendix 11 – McMullen County

Location Map of Hydrograph Wells

Hydrographs

Note that pumping data are expressed in three zones:

- Pump 1 = pumping from cell where well is located
- Pump 2 = pumping in cells adjacent to Zone 1
- Pump 3 = pumping in cells adjacent to Zone 2

Screen Bottom and Screen Top = Elevation of Well Completion Interval

Land Surface = Elevation of Land Surface at Well

Groundwater Elevations

- Measured = Actual data from TWDB database
- Calibrated Model = Results for cell defined by well from calibrated model
- DFC = Results for cell defined by well from Scenario 4 of GAM Run 09-034

Drawdown Comparison Maps for 2001, 2006 and 2011

Summary of Drawdown Comparisons

Table analogous to Table 5 in text summarizing annual average drawdown (actual and DFC)

Histogram of Differences between DFC Drawdown and Actual Drawdown for All Years

Figure analogous to Figure 23 in text showing differences between actual drawdown and DFC conditions

Hydrograph of Actual Drawdown and DFC Drawdown

Figure analogous to Figure 26 in text showing time history of drawdown (actual and DFC) from 2000 to 2011

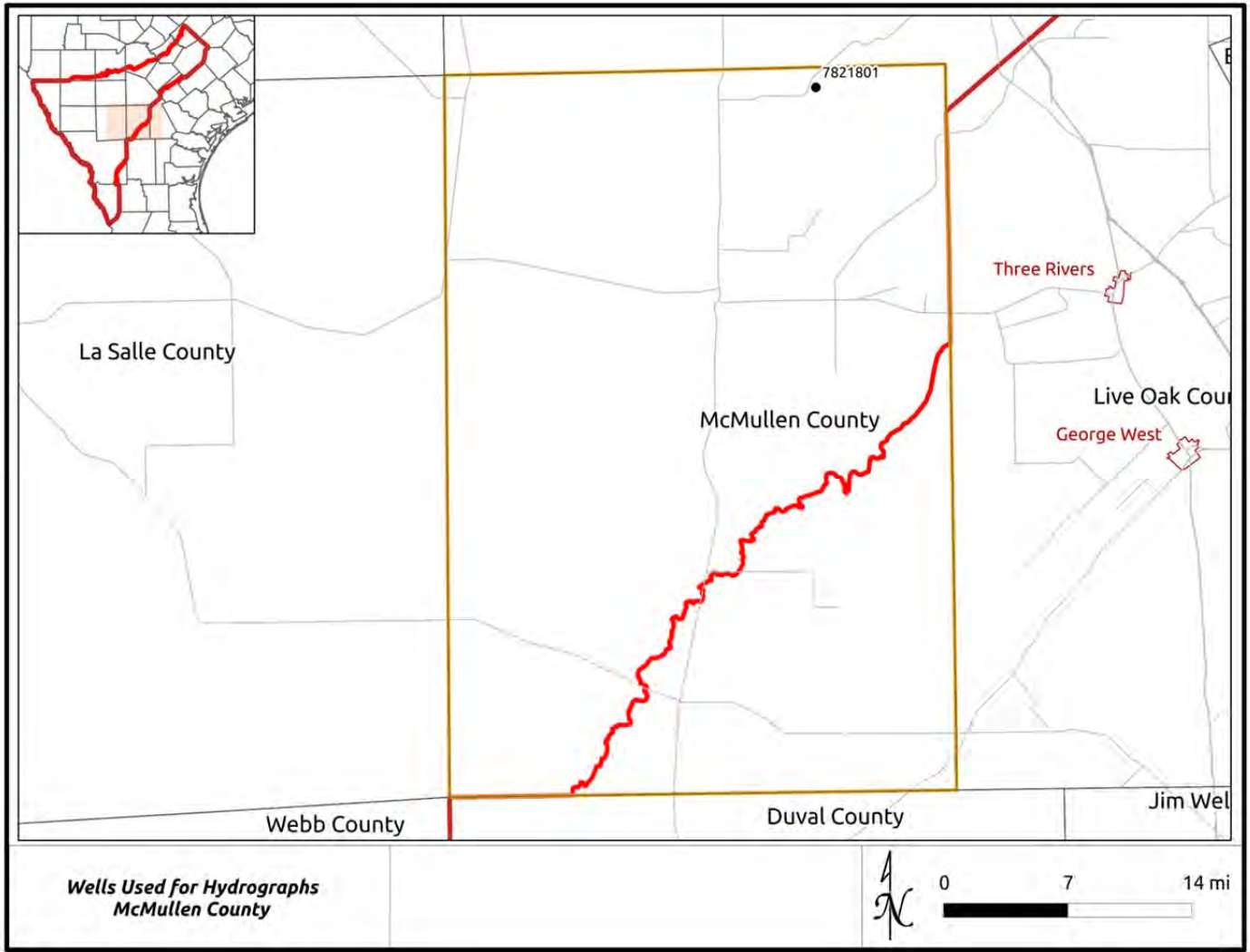

Location Map of Wells with Hydrographs – McMullen County

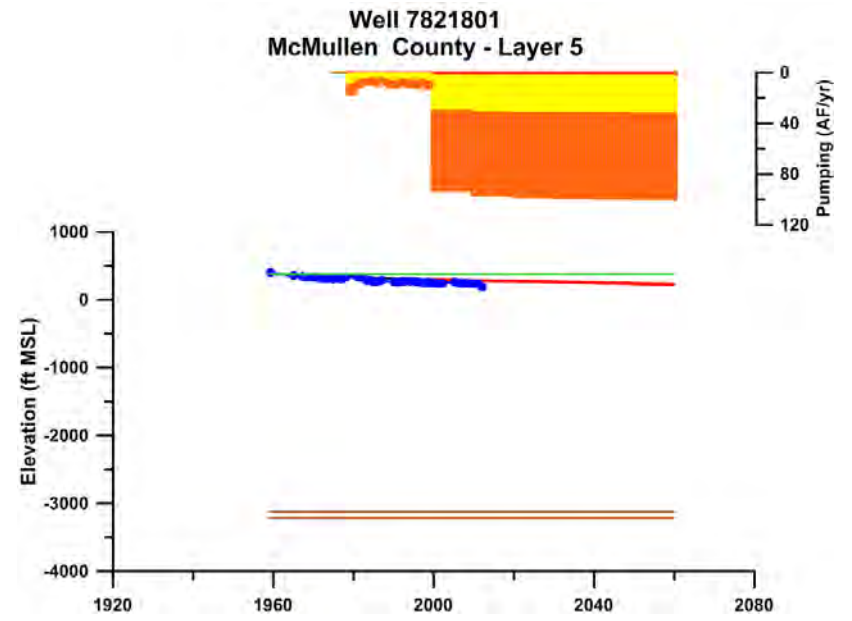
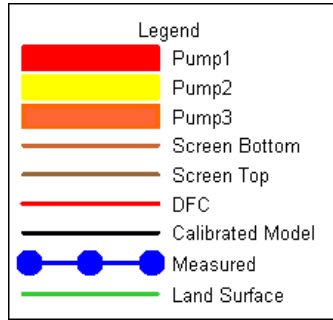

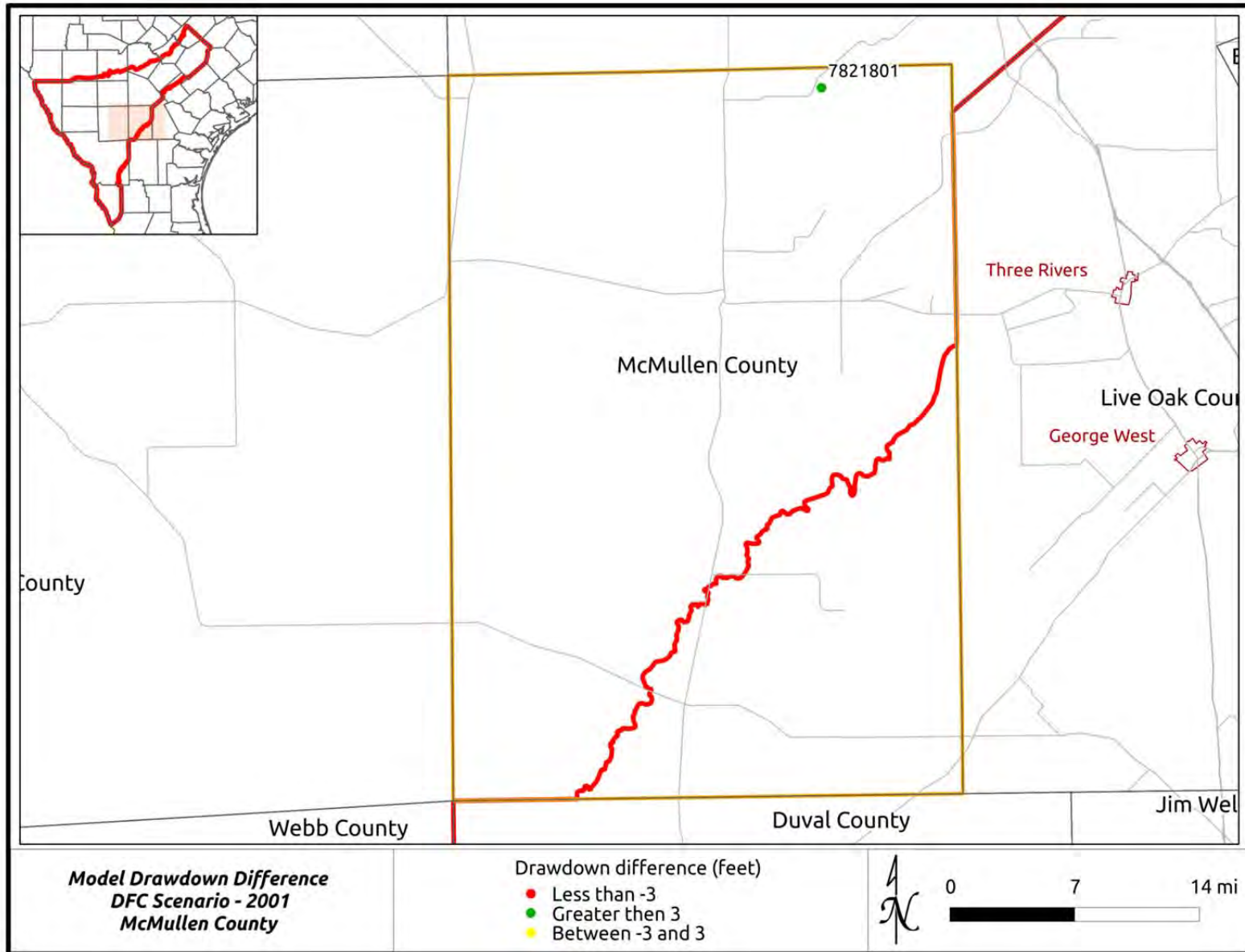

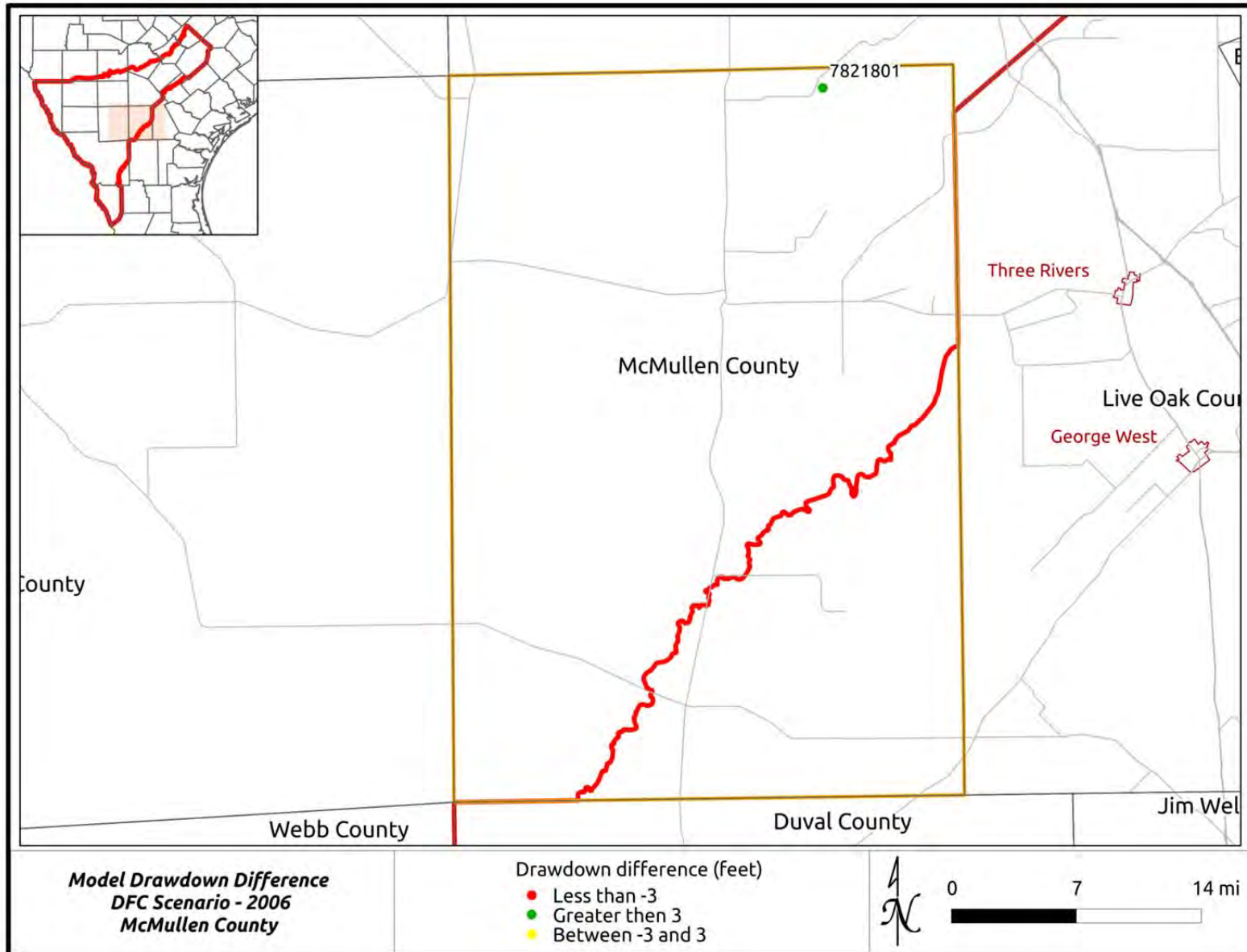

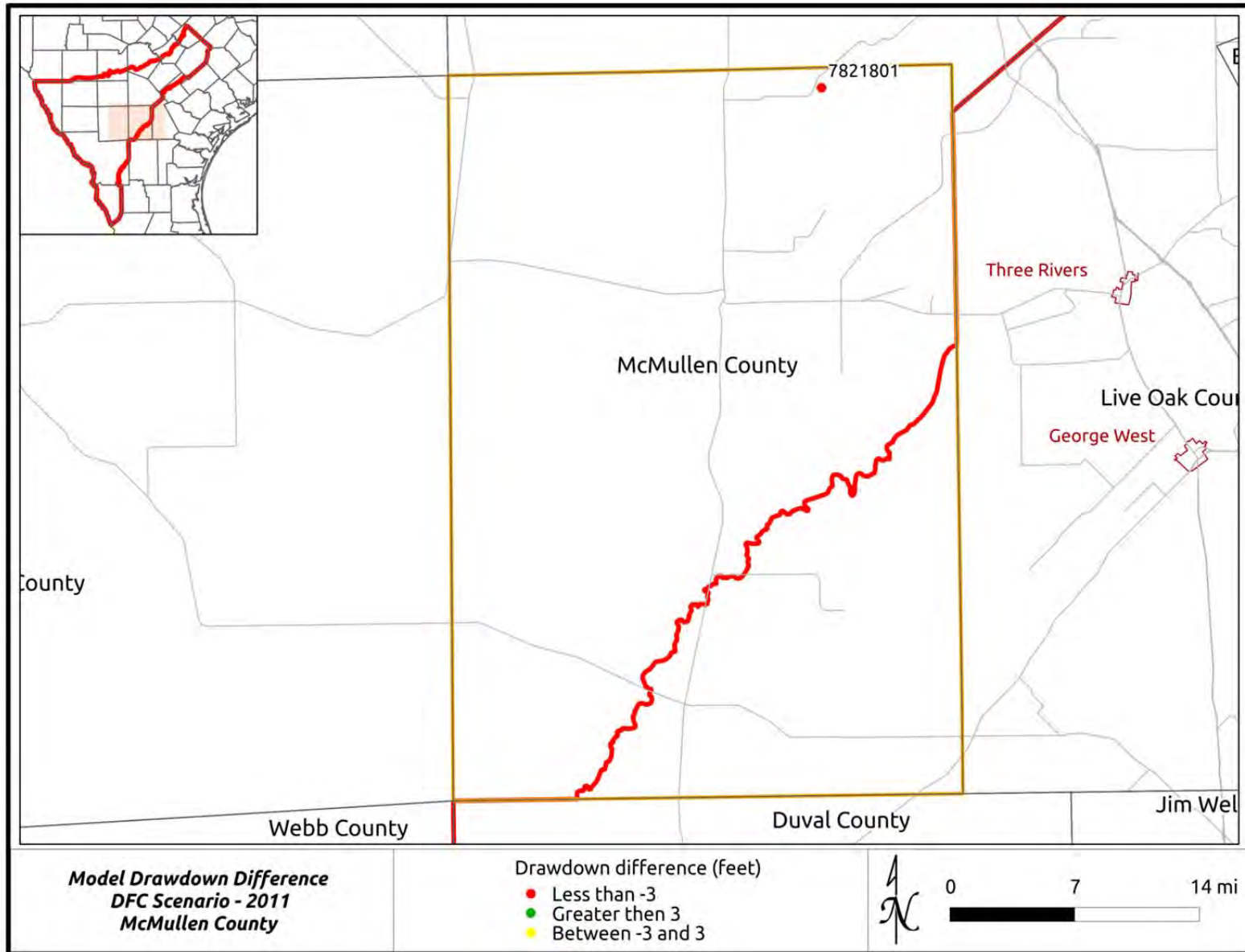

Summary of Drawdown Comparisons - McMullen County

<i>Column 1</i>	<i>Column 2</i>	<i>Column 3</i>	<i>Column 4</i>	<i>Column 5</i>	<i>Column 6</i>	<i>Column 7</i>
Year	Precipitation (% Avg)	County-Wide Average DFC	Number of Actual Drawdown Data Points	Average Actual Drawdown for Wells with Data	Average DFC for Wells with Data	Column 6 minus Column 5
2000	90	0.77	1	8.55	9.84	1.29
2001	101	1.47	1	7.17	11.55	4.38
2002	113	2.15				
2003	96	2.82				
2004	132	3.48				
2005	75	4.14	1	-0.95	16.99	17.94
2006	86	4.80	1	12.70	18.40	5.70
2007	142	5.45	1	0.08	19.81	19.73
2008	74	6.10	1	8.40	21.21	12.81
2009	76	6.74	1	8.42	22.59	14.17
2010	132	7.37	1	9.56	24.25	14.69
2011	45	7.93	1	54.48	25.49	-28.99

McMullen County - All Years

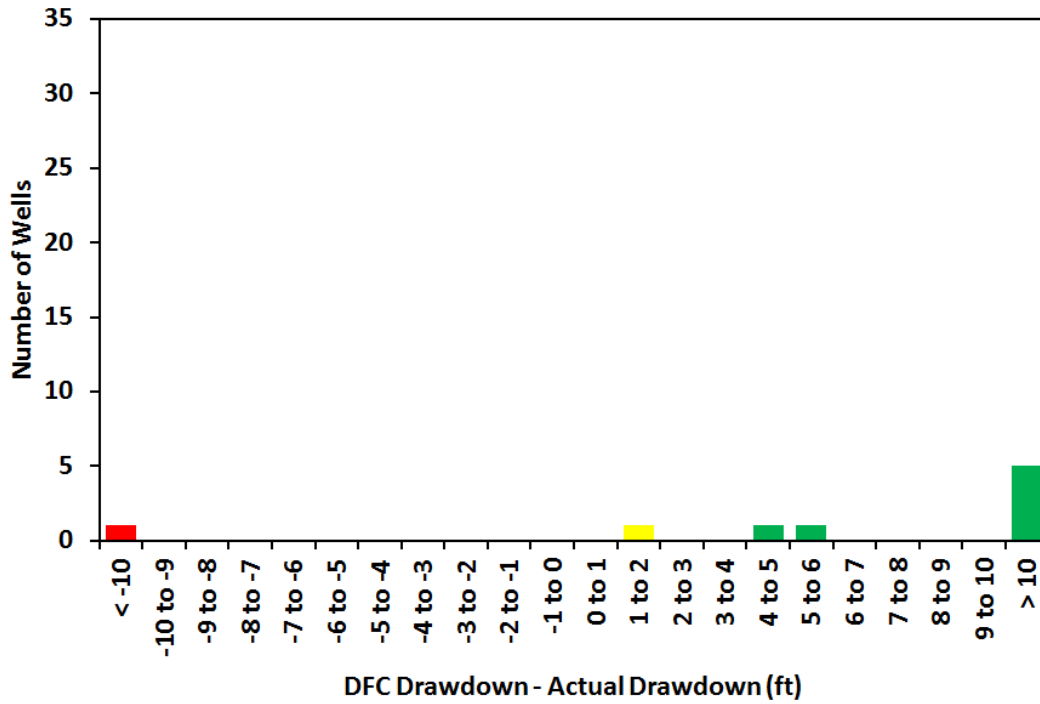

McMullen County

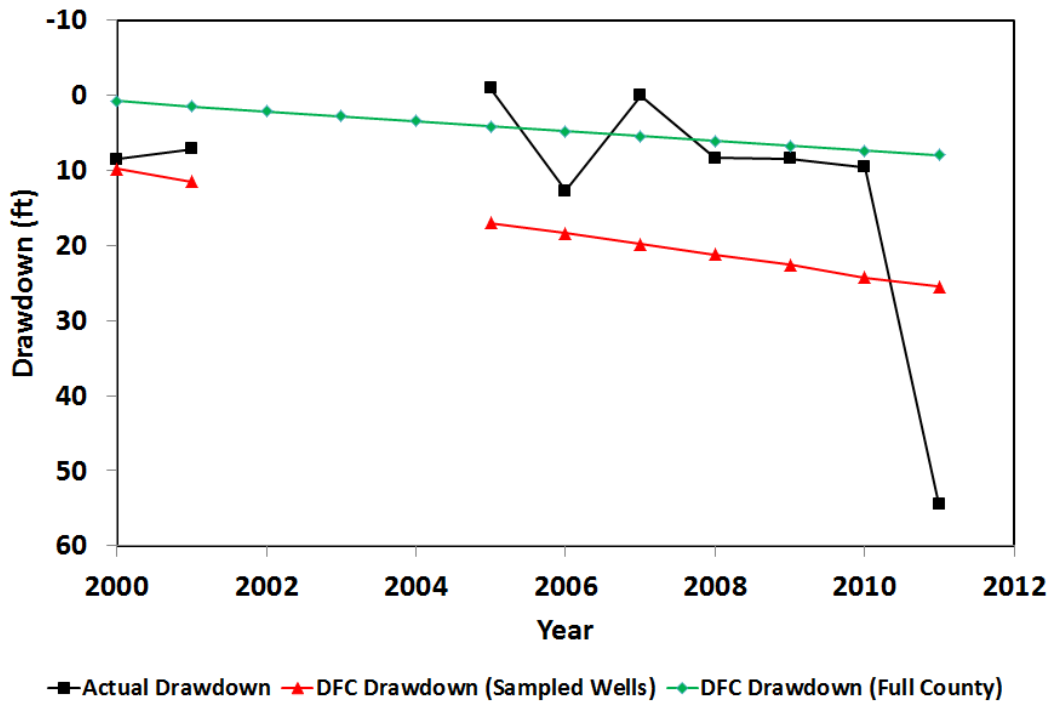

Appendix 12 – Medina County

Location Map of Hydrograph Wells

Hydrographs

Note that pumping data are expressed in three zones:

- Pump 1 = pumping from cell where well is located
- Pump 2 = pumping in cells adjacent to Zone 1
- Pump 3 = pumping in cells adjacent to Zone 2

Screen Bottom and Screen Top = Elevation of Well Completion Interval

Land Surface = Elevation of Land Surface at Well

Groundwater Elevations

- Measured = Actual data from TWDB database
- Calibrated Model = Results for cell defined by well from calibrated model
- DFC = Results for cell defined by well from Scenario 4 of GAM Run 09-034

Drawdown Comparison Maps for 2001, 2006 and 2011

Summary of Drawdown Comparisons

Table analogous to Table 5 in text summarizing annual average drawdown (actual and DFC)

Histogram of Differences between DFC Drawdown and Actual Drawdown for All Years

Figure analogous to Figure 23 in text showing differences between actual drawdown and DFC conditions

Hydrograph of Actual Drawdown and DFC Drawdown

Figure analogous to Figure 26 in text showing time history of drawdown (actual and DFC) from 2000 to 2011

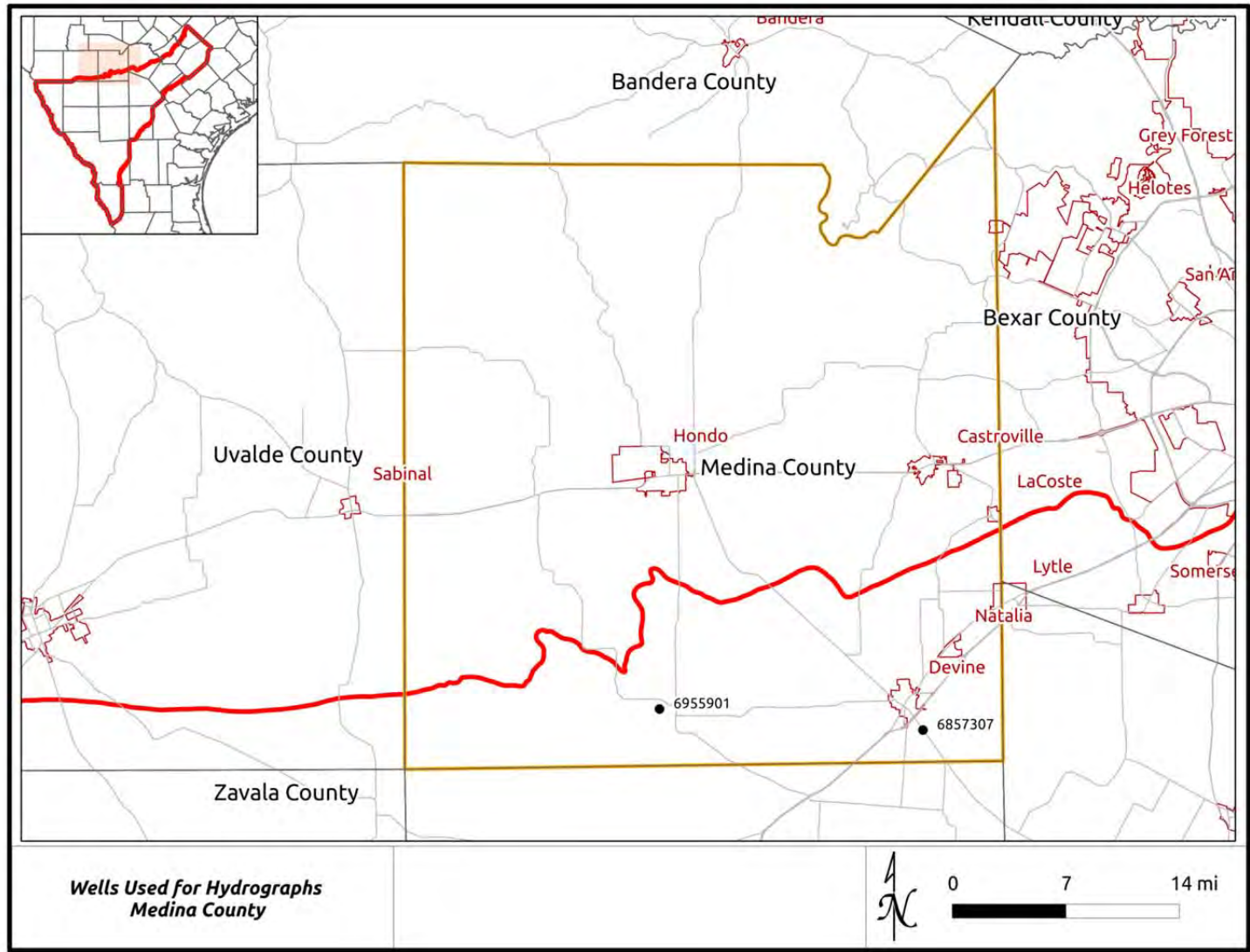

Location Map of Wells with Hydrographs – Medina County

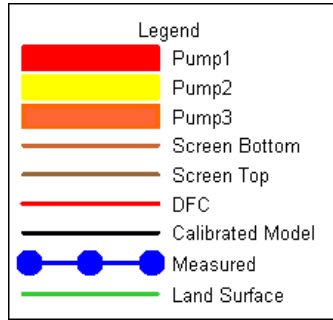

**Well 6857307
Medina County - Layer 5**

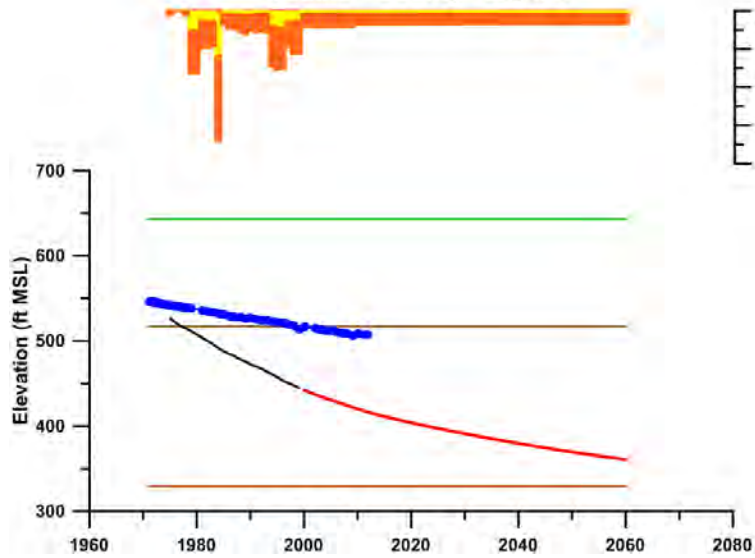

**Well 6955901
Medina County - Layer 8**

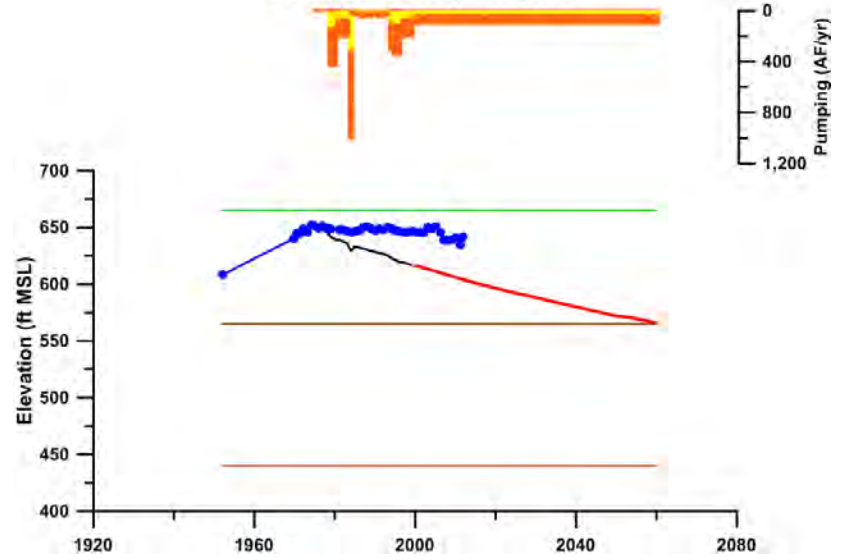

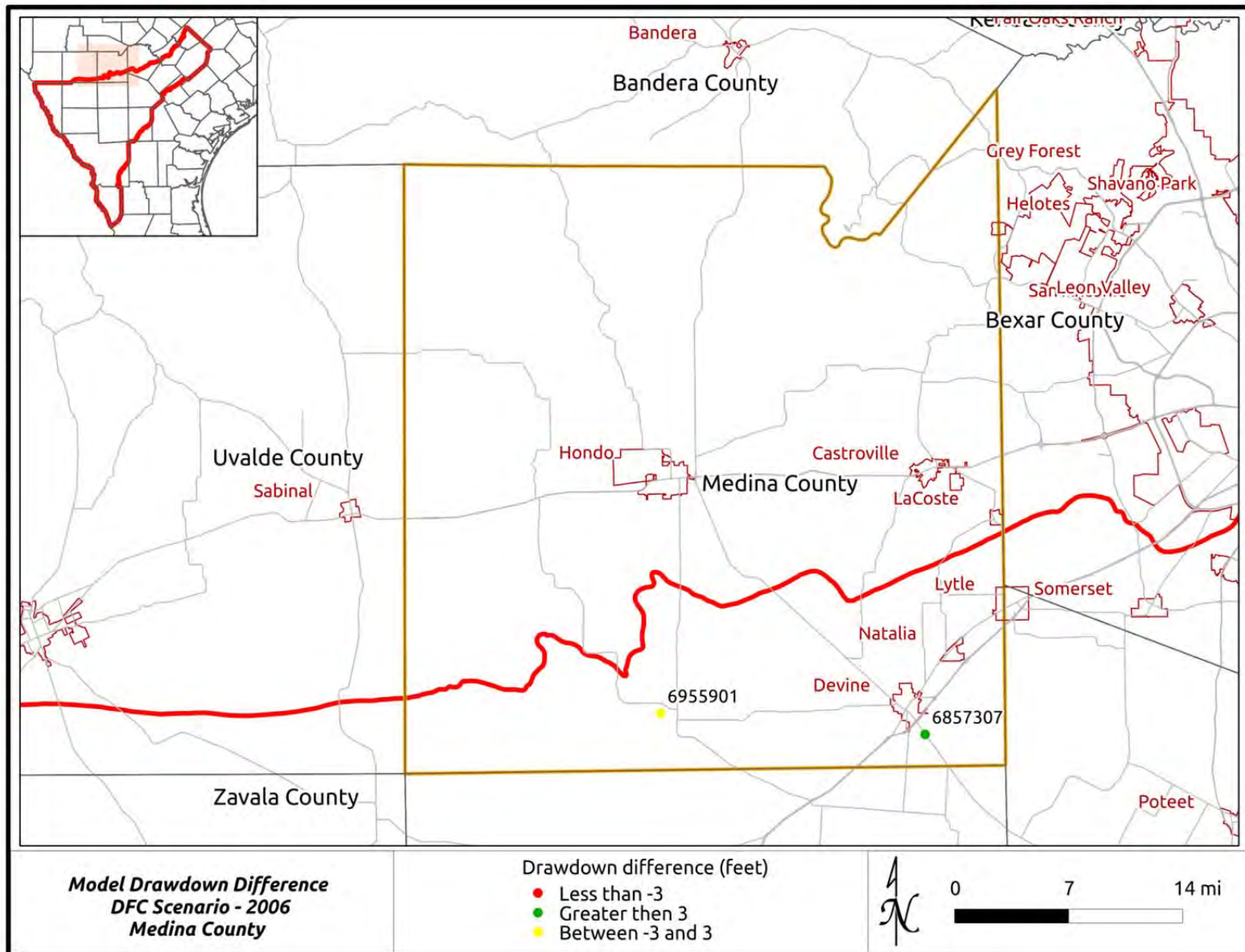

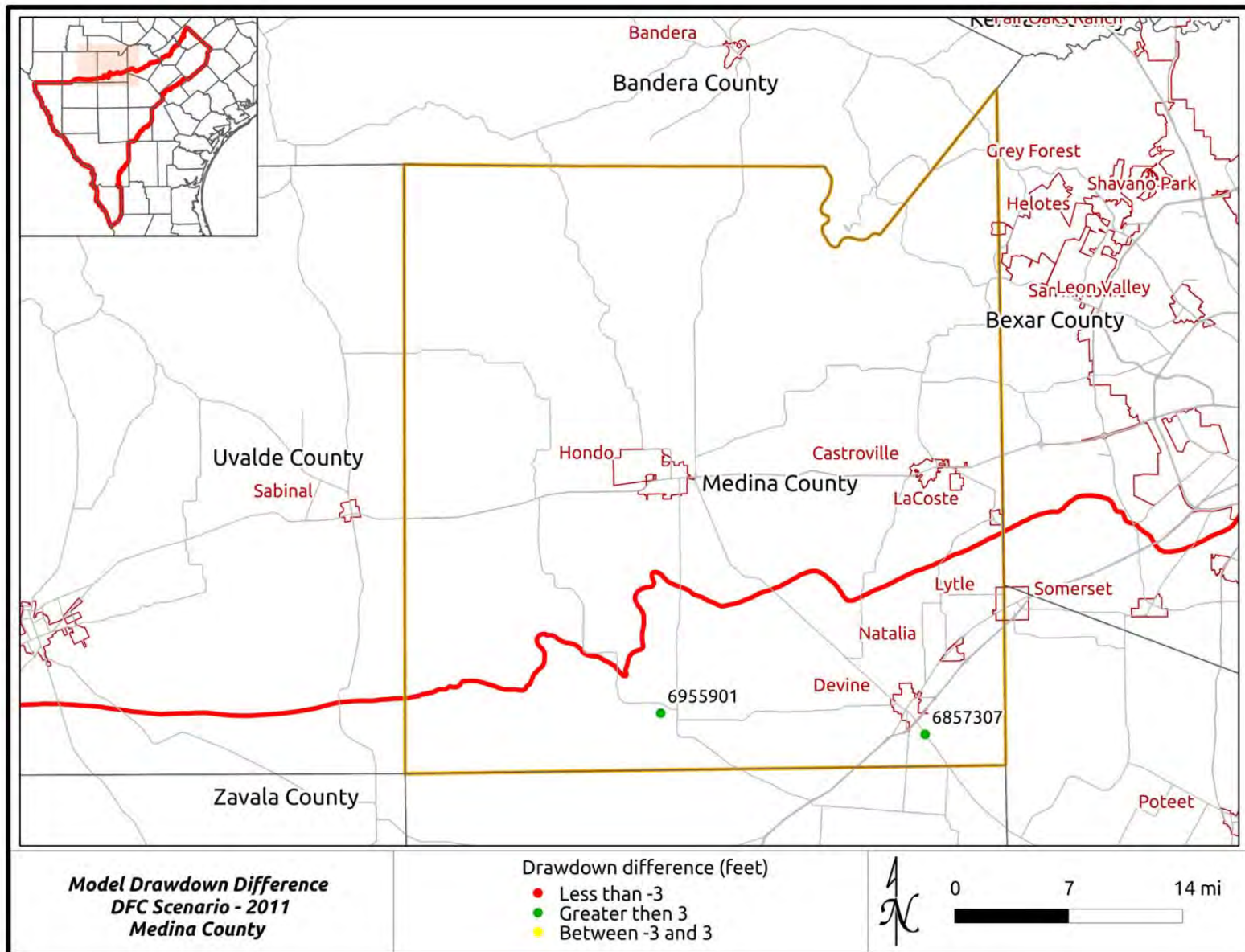

Summary of Drawdown Comparisons - Medina County

<i>Column 1</i>	<i>Column 2</i>	<i>Column 3</i>	<i>Column 4</i>	<i>Column 5</i>	<i>Column 6</i>	<i>Column 7</i>
Year	Precipitation (% Avg)	County-Wide Average DFC	Number of Actual Drawdown Data Points	Average Actual Drawdown for Wells with Data	Average DFC for Wells with Data	Column 6 minus Column 5
2000	90	0.18	1	-0.07	0.50	0.57
2001	101	0.70	2	1.05	3.35	2.30
2002	113	1.32	2	-0.46	5.04	5.50
2003	96	1.97	2	0.44	7.80	7.37
2004	132	2.63	2	-0.43	8.32	8.75
2005	75	3.31	2	2.96	9.94	6.98
2006	86	3.98	2	6.84	11.54	4.70
2007	142	4.66	2	7.46	13.13	5.68
2008	74	5.34	2	8.24	14.72	6.48
2009	76	6.02	2	6.60	16.29	9.70
2010	132	6.68	2	9.90	17.86	7.96
2011	45	7.31	2	6.59	19.36	12.77

Medina County - All Years

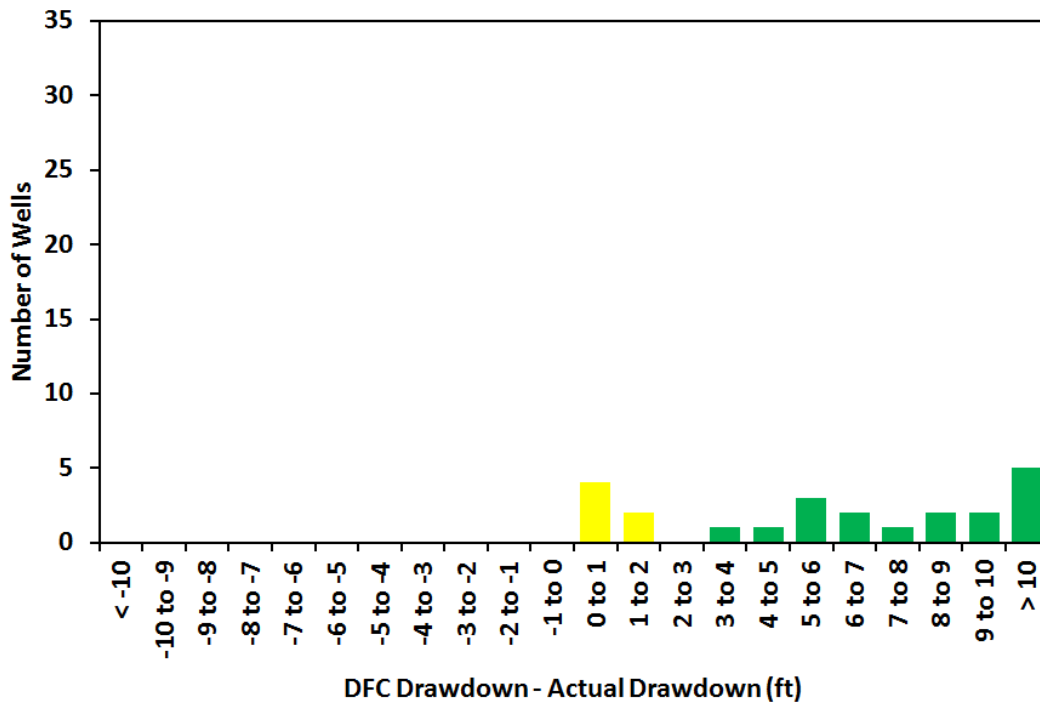

Medina County

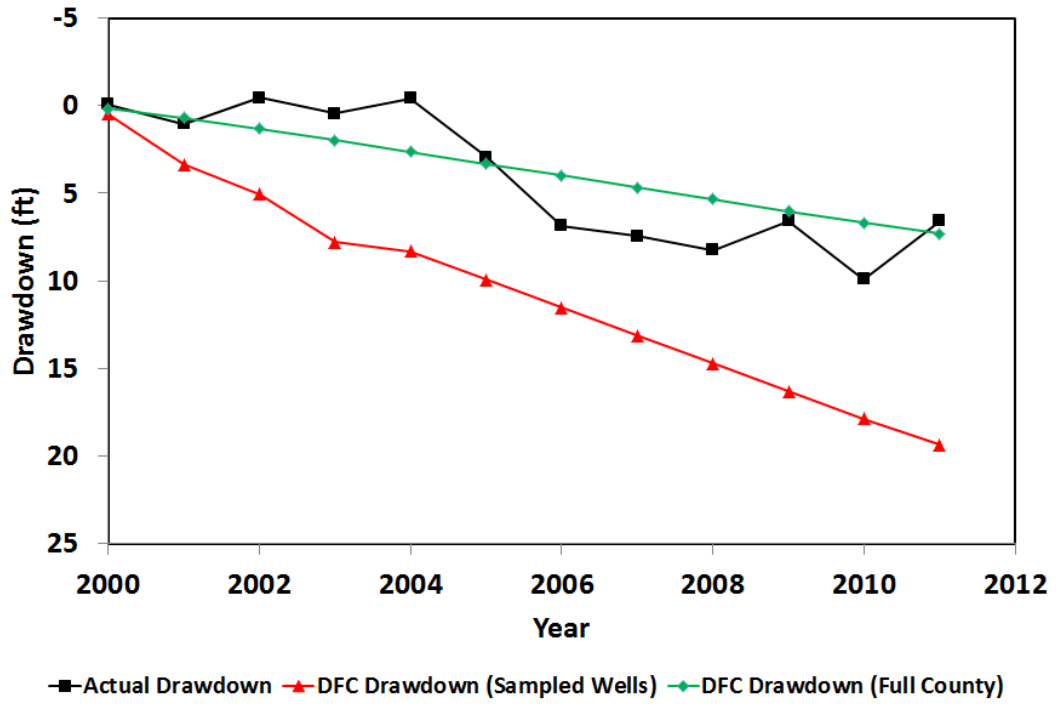

Appendix 13 – Webb County

Location Map of Hydrograph Wells

Hydrographs

Note that pumping data are expressed in three zones:

- Pump 1 = pumping from cell where well is located
- Pump 2 = pumping in cells adjacent to Zone 1
- Pump 3 = pumping in cells adjacent to Zone 2

Screen Bottom and Screen Top = Elevation of Well Completion Interval

Land Surface = Elevation of Land Surface at Well

Groundwater Elevations

- Measured = Actual data from TWDB database
- Calibrated Model = Results for cell defined by well from calibrated model
- DFC = Results for cell defined by well from Scenario 4 of GAM Run 09-034

Drawdown Comparison Maps for 2001, 2006 and 2011

Summary of Drawdown Comparisons

Table analogous to Table 5 in text summarizing annual average drawdown (actual and DFC)

Histogram of Differences between DFC Drawdown and Actual Drawdown for All Years

Figure analogous to Figure 23 in text showing differences between actual drawdown and DFC conditions

Hydrograph of Actual Drawdown and DFC Drawdown

Figure analogous to Figure 26 in text showing time history of drawdown (actual and DFC) from 2000 to 2011

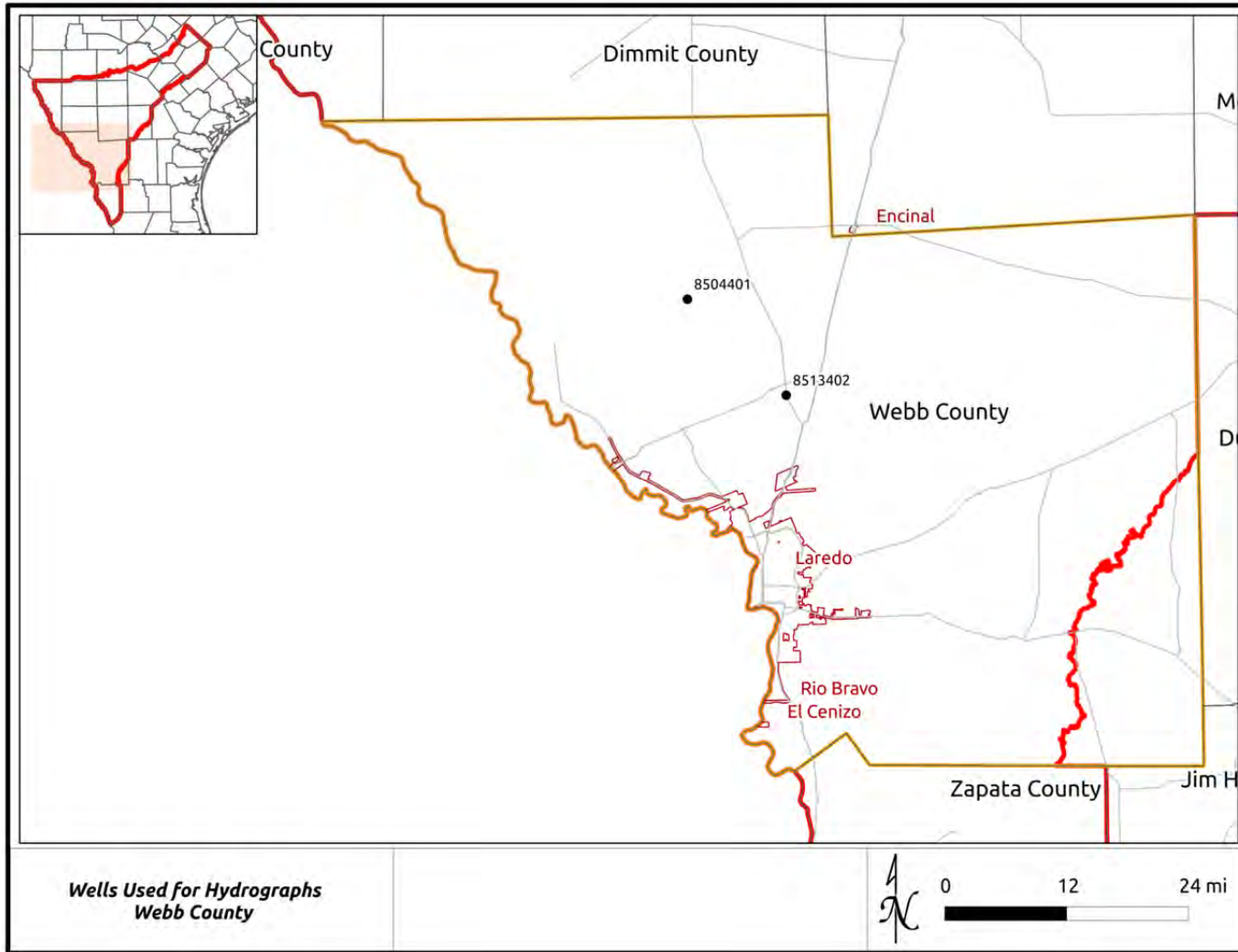

Location Map of Wells with Hydrographs – Webb County

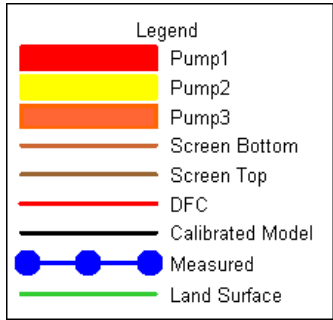

Well 8504401
Webb County - Layer 5

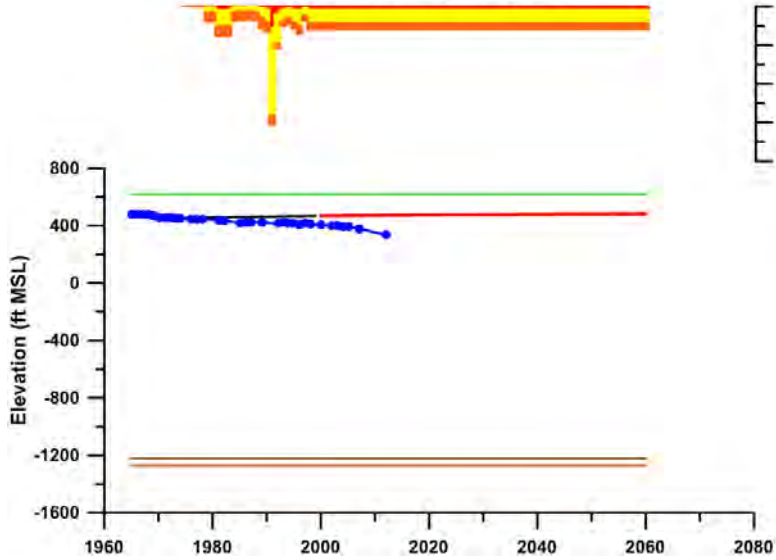

Well 8513402
Webb County - Layer 3

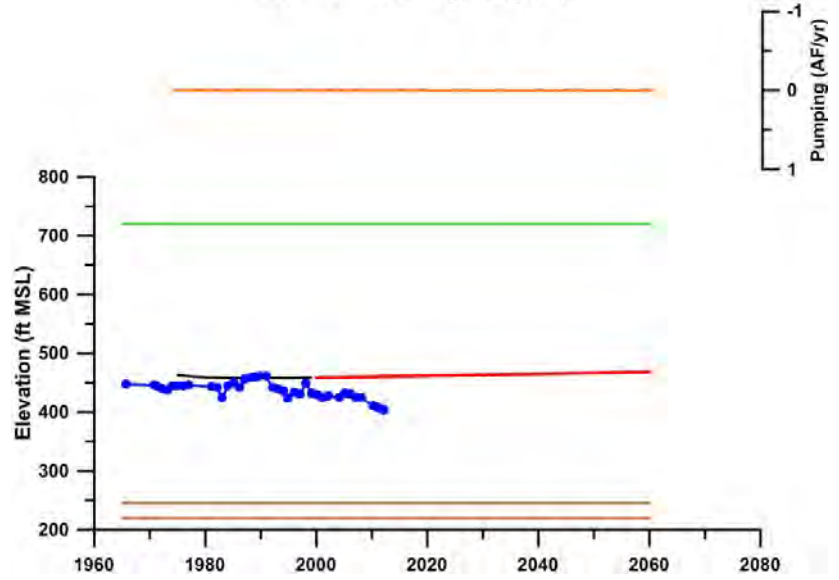

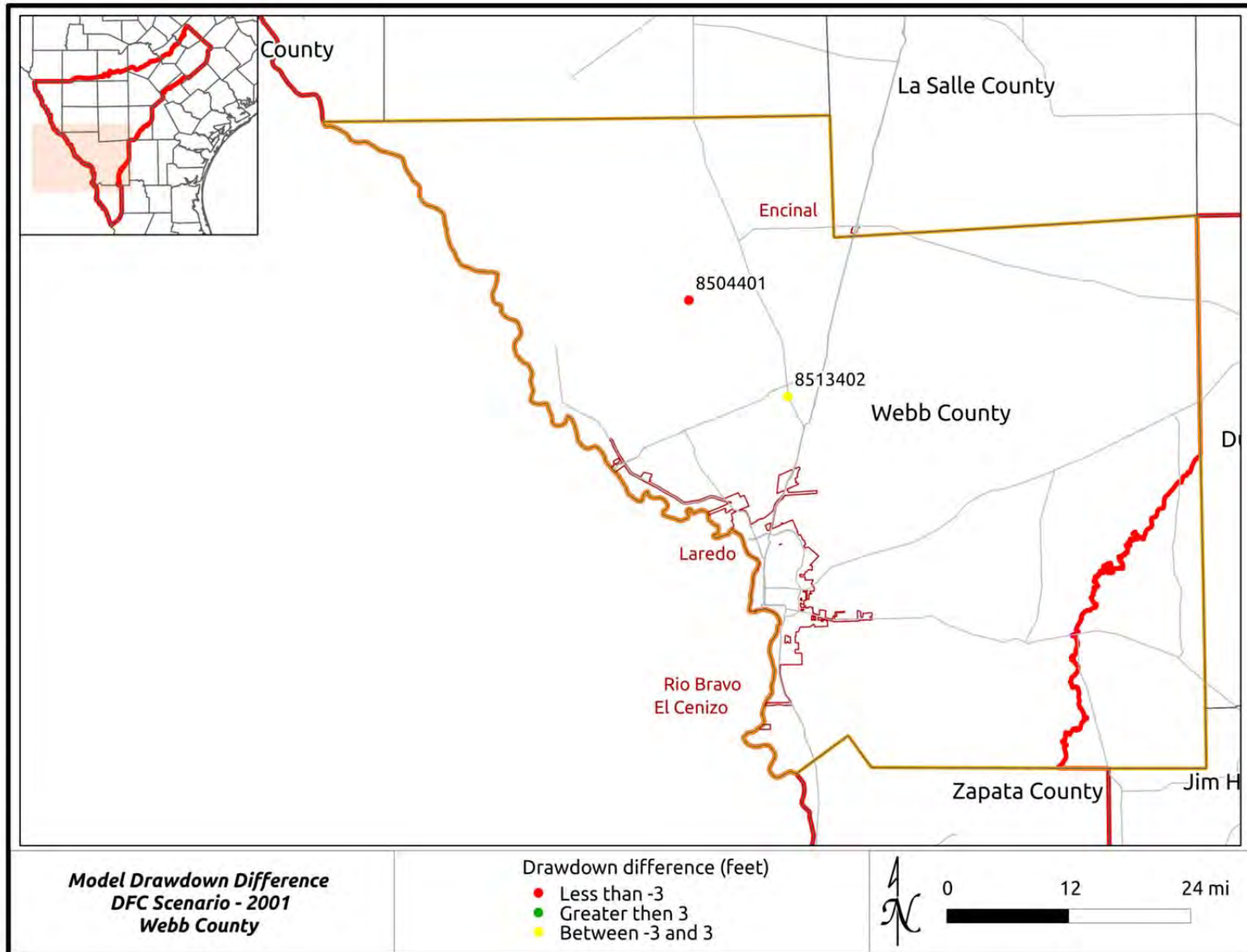

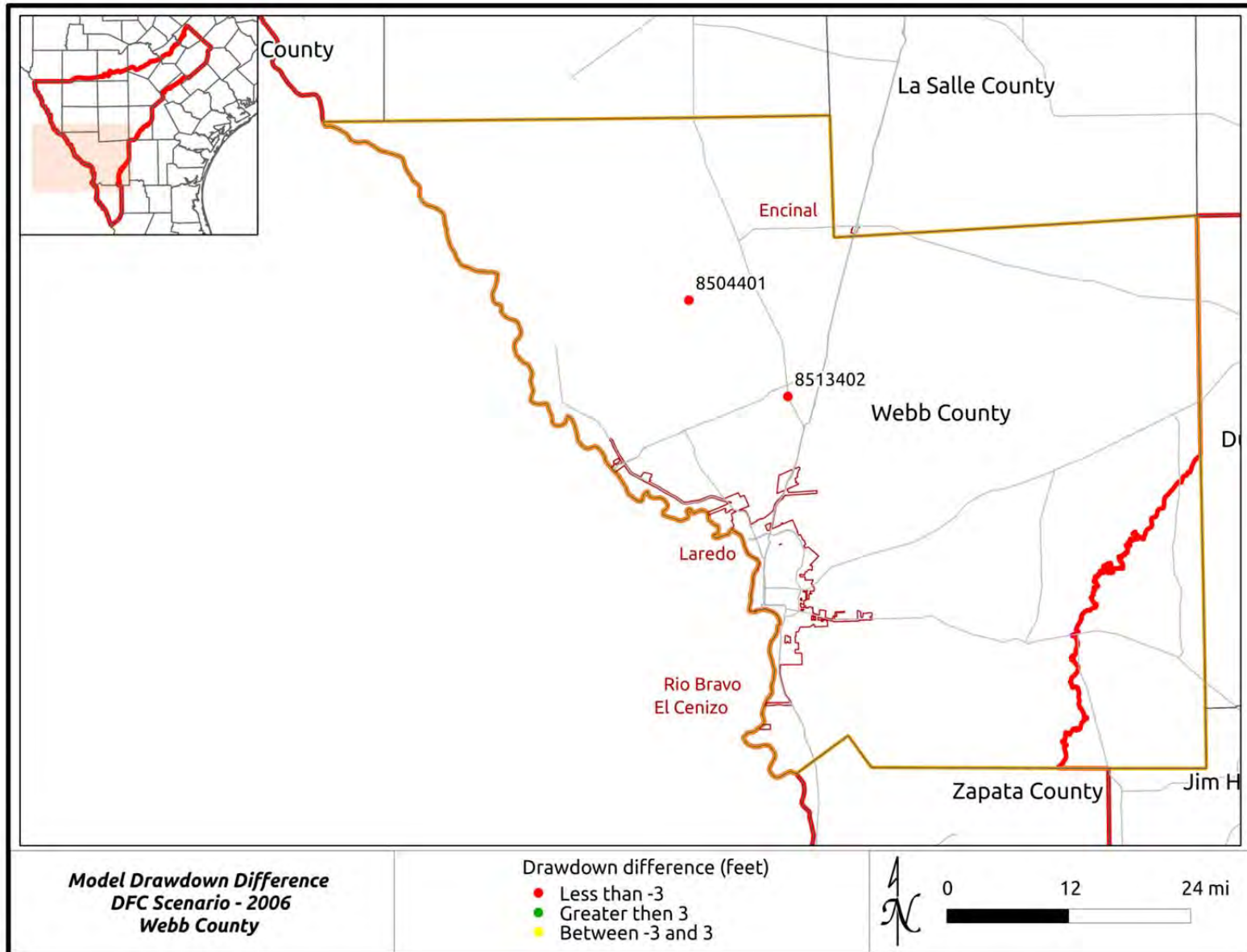

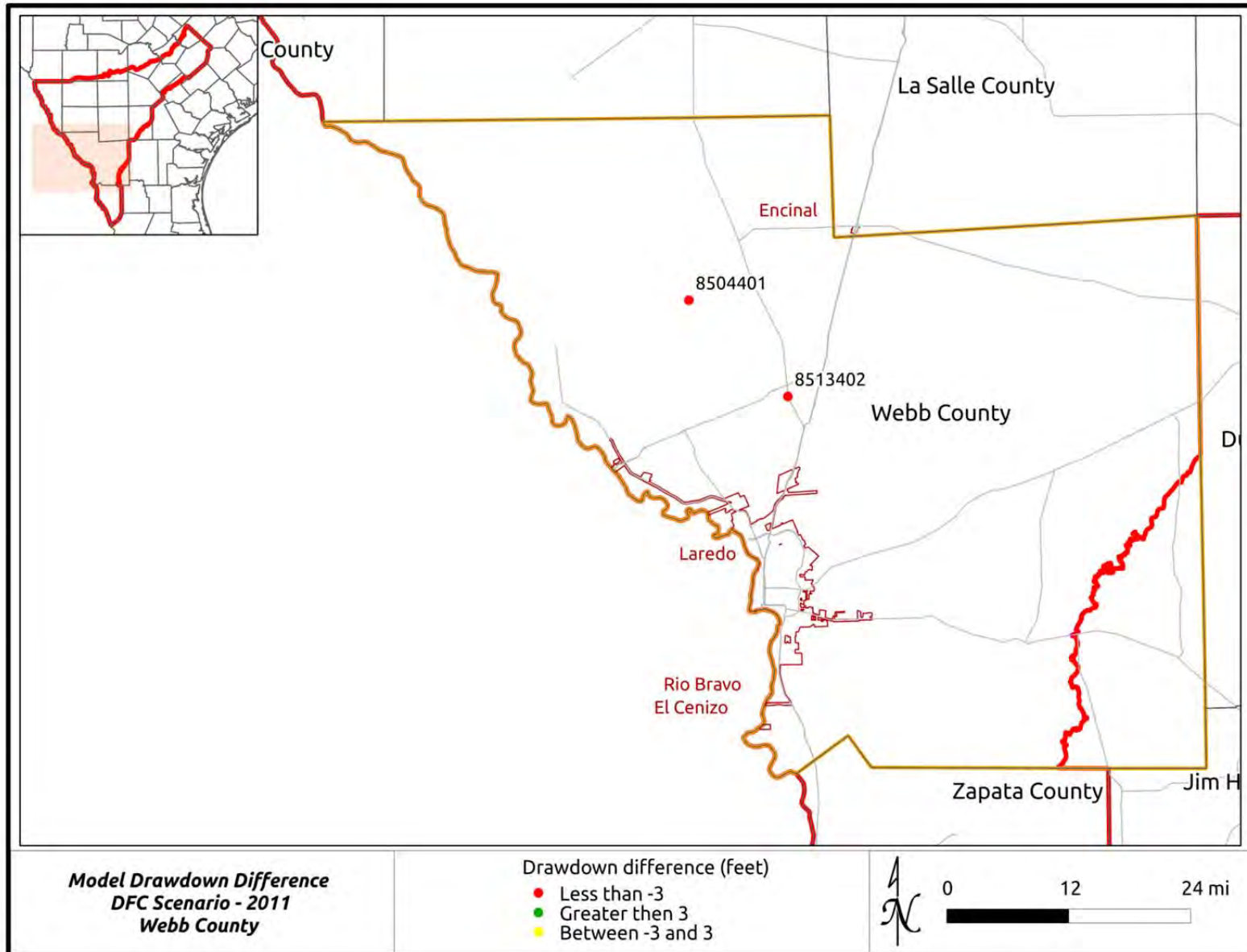

Summary of Drawdown Comparisons - Webb County

<i>Column 1</i>	<i>Column 2</i>	<i>Column 3</i>	<i>Column 4</i>	<i>Column 5</i>	<i>Column 6</i>	<i>Column 7</i>
Year	Precipitation (% Avg)	County-Wide Average DFC	Number of Actual Drawdown Data Points	Average Actual Drawdown for Wells with Data	Average DFC for Wells with Data	Column 6 minus Column 5
2000	90	-0.06	1	3.94	3.94	3.94
2001	101	-0.13	2	4.56	-0.52	-5.07
2002	113	-0.20	1	9.38	9.38	9.38
2003	96	-0.27	1	4.04	4.04	4.04
2004	132	-0.34	2	4.95	-1.29	-6.24
2005	75	-0.41	1	-0.60	-0.60	-0.60
2006	86	-0.48	2	16.23	-1.78	-18.01
2007	142	-0.55	1	3.84	3.84	3.84
2008	74	-0.62				
2009	76	-0.69	1	19.19	19.19	19.19
2010	132	-0.76	1	21.27	21.27	21.27
2011	45	-0.82	2	48.80	-2.99	-51.79

Webb County - All Years

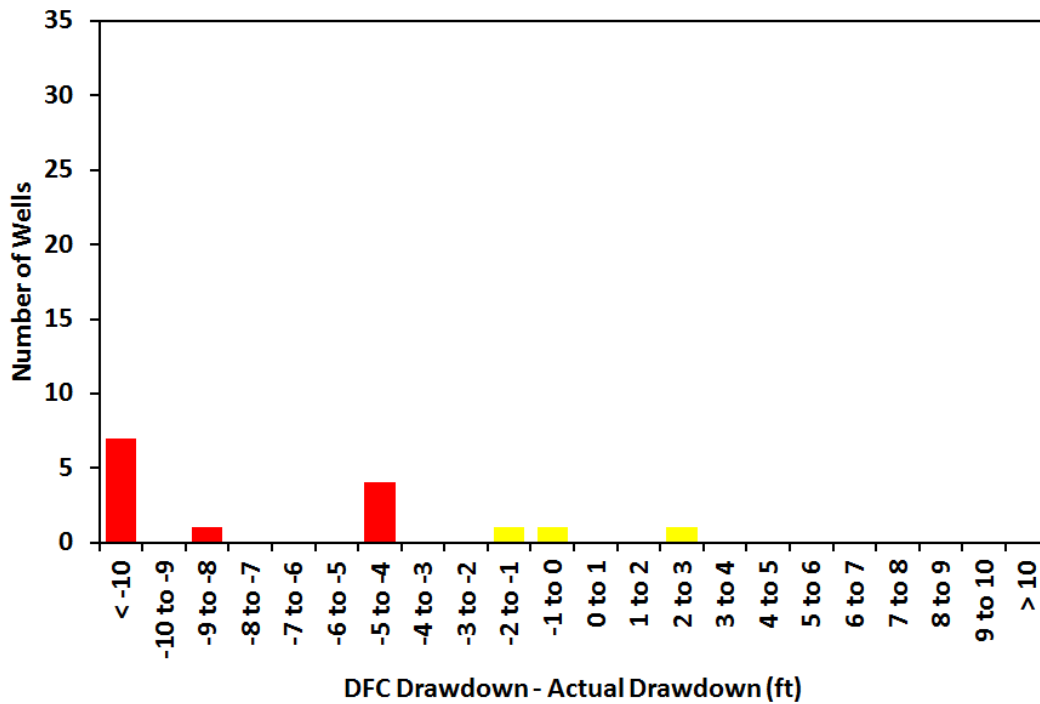

Webb County

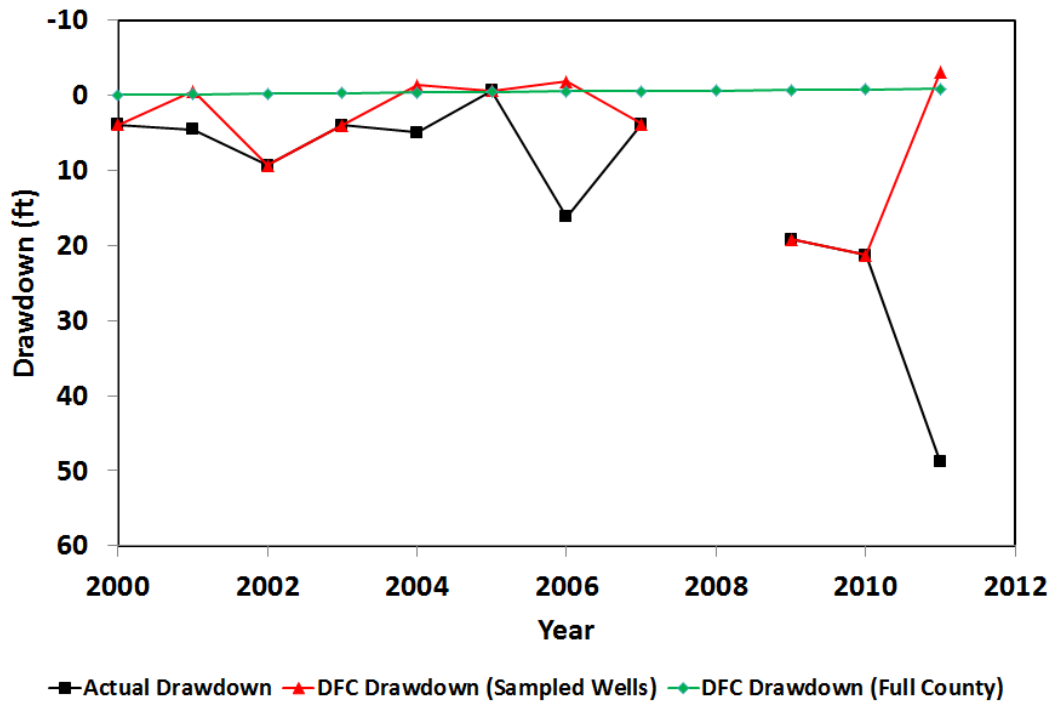

Appendix 14 – Wilson County

Location Map of Hydrograph Wells

Hydrographs

Note that pumping data are expressed in three zones:

- Pump 1 = pumping from cell where well is located
- Pump 2 = pumping in cells adjacent to Zone 1
- Pump 3 = pumping in cells adjacent to Zone 2

Screen Bottom and Screen Top = Elevation of Well Completion Interval

Land Surface = Elevation of Land Surface at Well

Groundwater Elevations

- Measured = Actual data from TWDB database
- Calibrated Model = Results for cell defined by well from calibrated model
- DFC = Results for cell defined by well from Scenario 4 of GAM Run 09-034

Drawdown Comparison Maps for 2001 and 2006

Summary of Drawdown Comparisons

Table analogous to Table 5 in text summarizing annual average drawdown (actual and DFC)

Histogram of Differences between DFC Drawdown and Actual Drawdown for All Years

Figure analogous to Figure 23 in text showing differences between actual drawdown and DFC conditions

Hydrograph of Actual Drawdown and DFC Drawdown

Figure analogous to Figure 26 in text showing time history of drawdown (actual and DFC) from 2000 to 2011

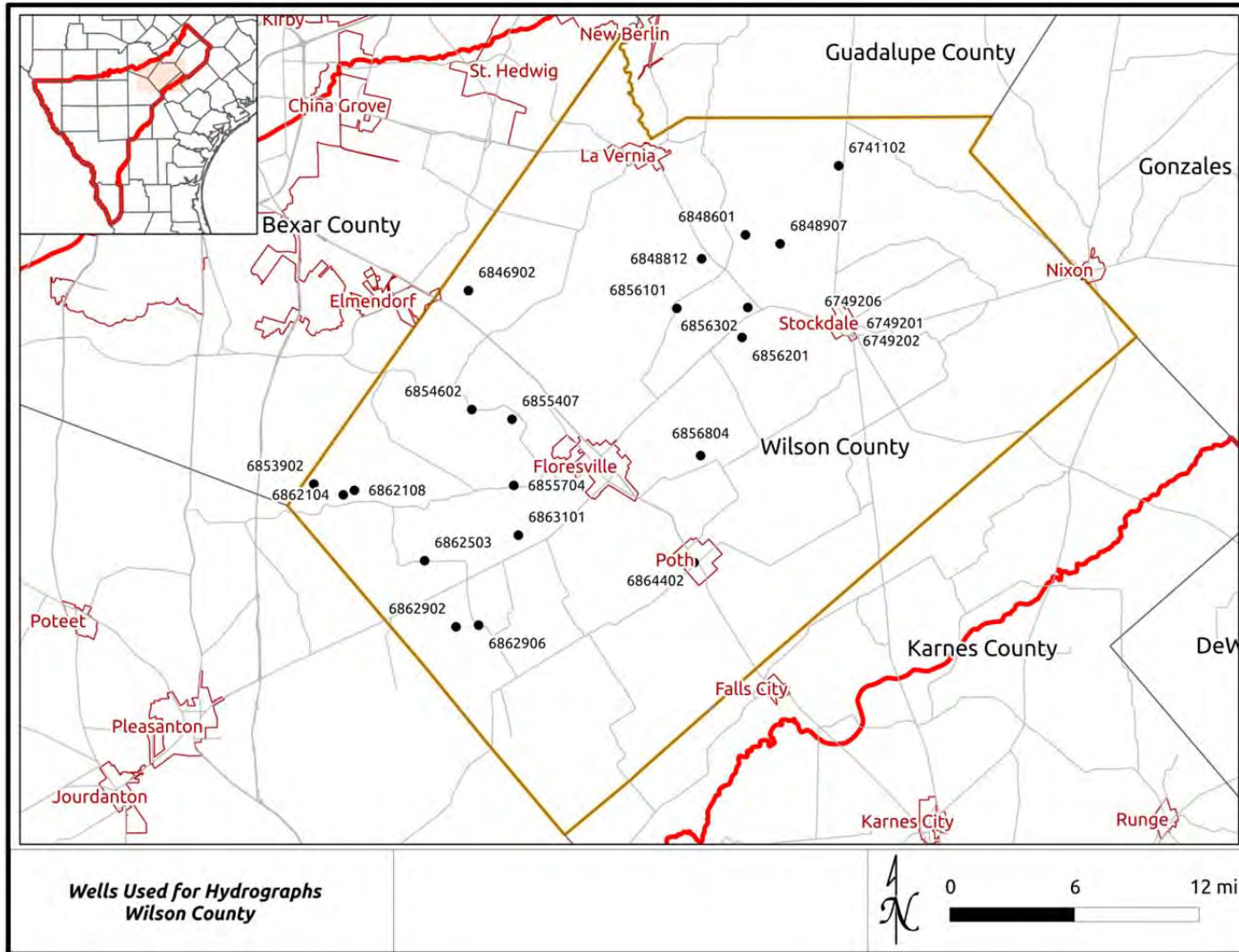

Location Map of Wells with Hydrographs – Webb County

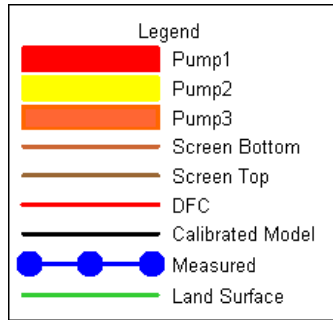

**Well 6741102
Wilson County - Layer 5**

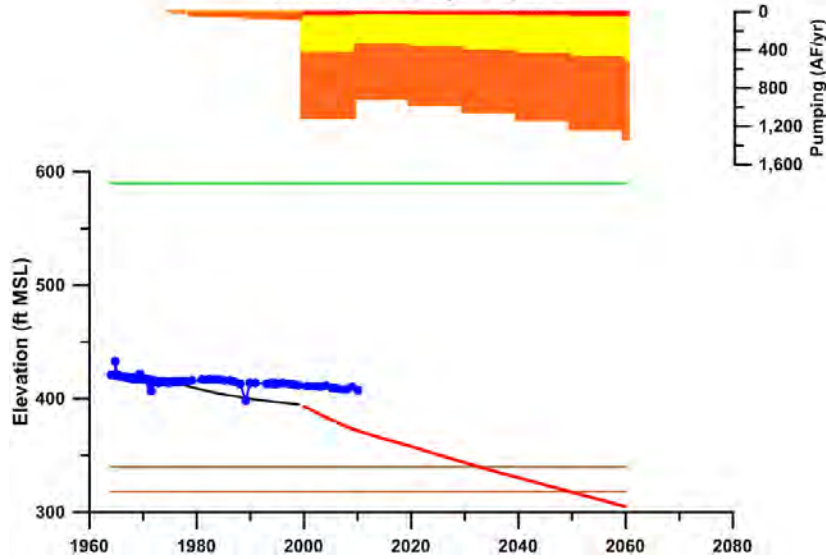

**Well 6749201
Wilson County - Layer 5**

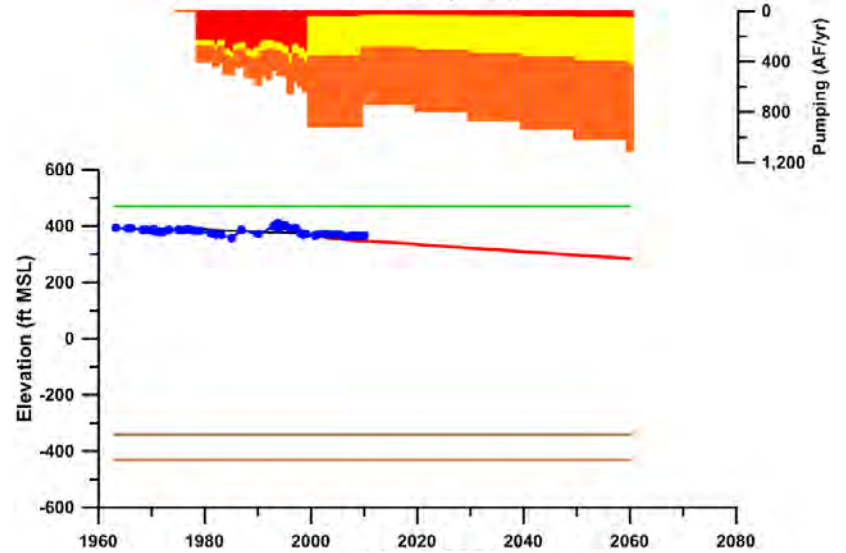

**Well 6749202
Wilson County - Layer 3**

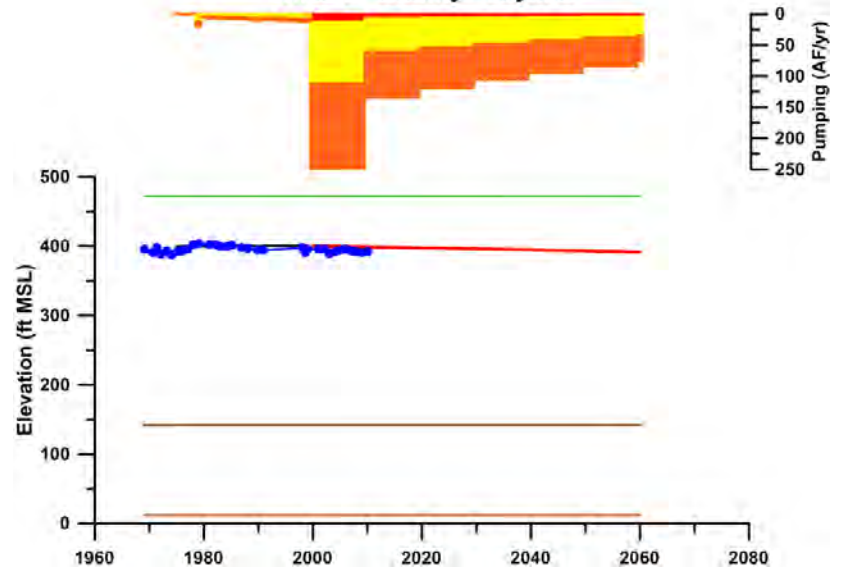

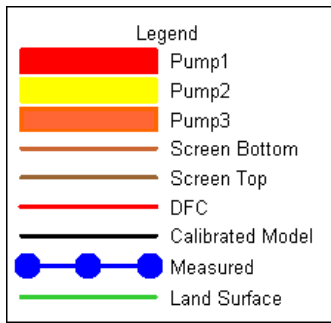

Well 6749206
Wilson County - Layer 5

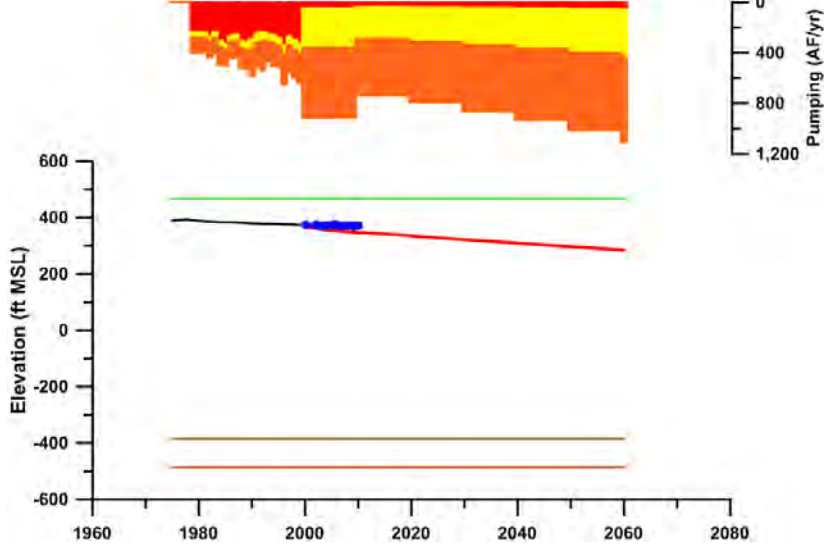

Well 6846902
Wilson County - Layer 8

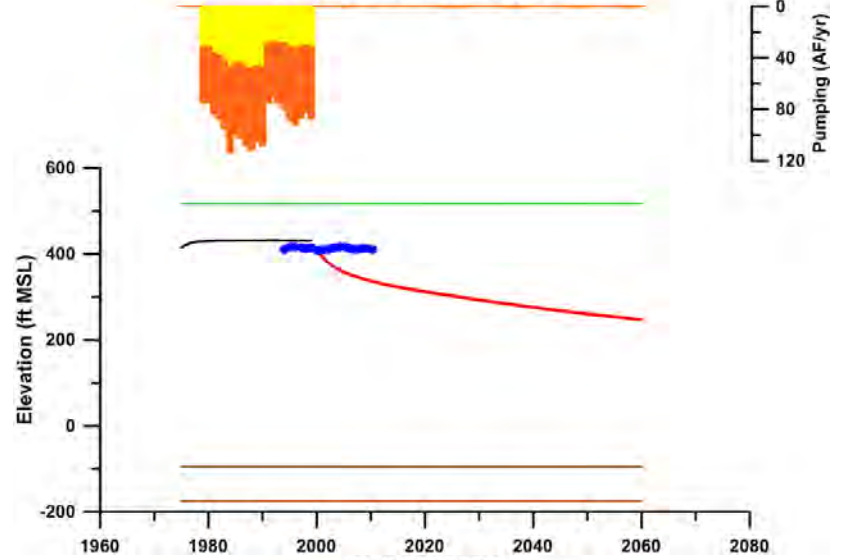

Well 6846902
Wilson County - Layer 8

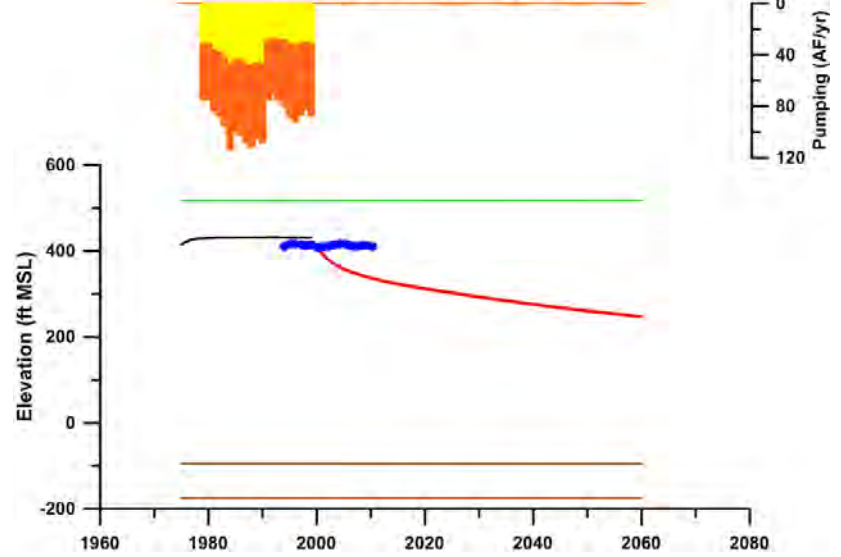

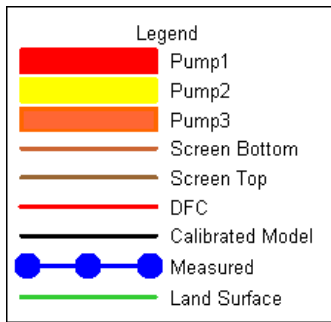

Well 6848601
Wilson County - Layer 5

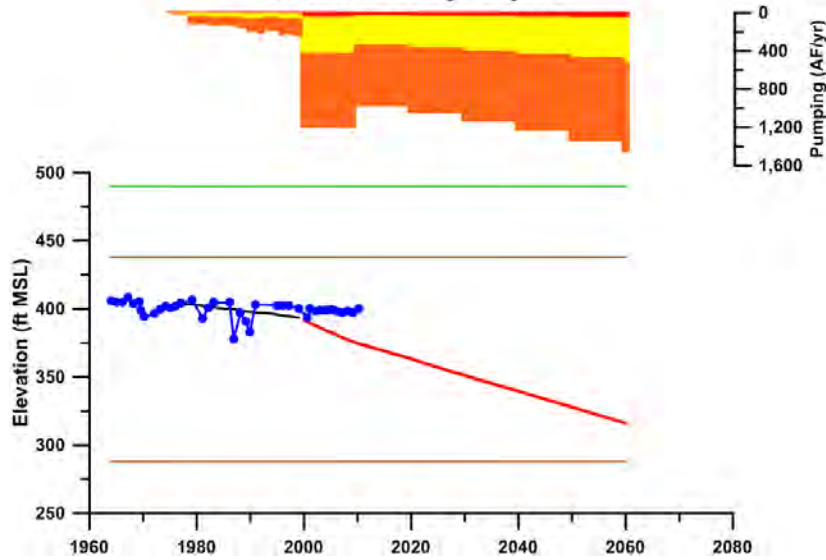

Well 6848812
Wilson County - Layer 5

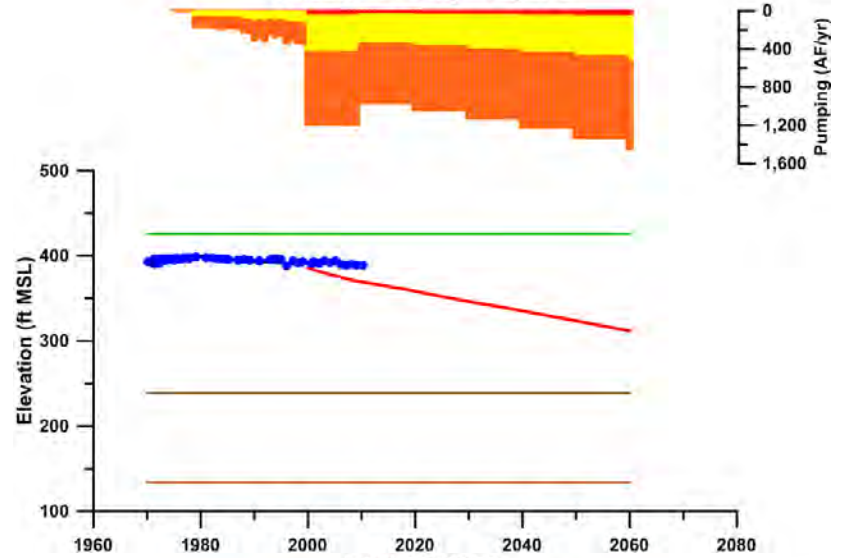

Well 6848907
Wilson County - Layer 5

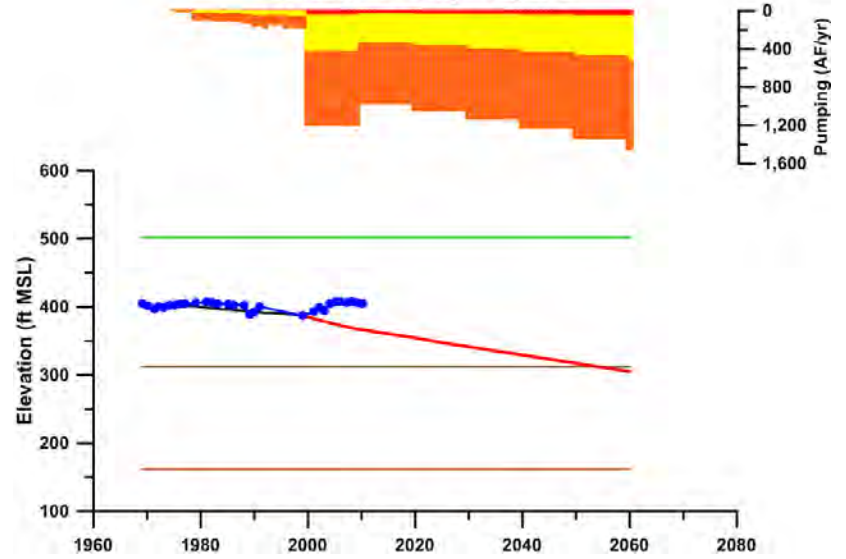

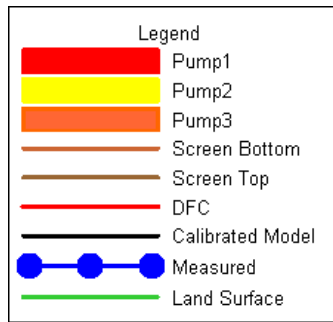

Well 6853902
Wilson County - Layer 5

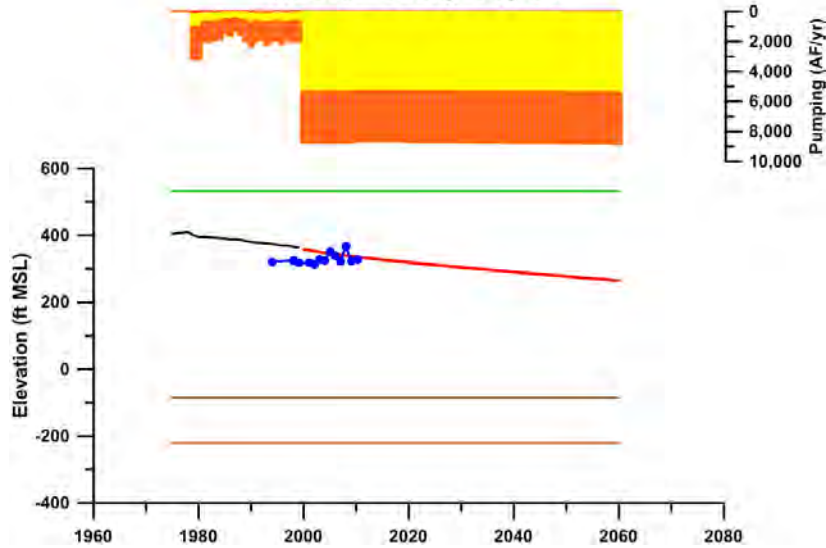

Well 6854602
Wilson County - Layer 4

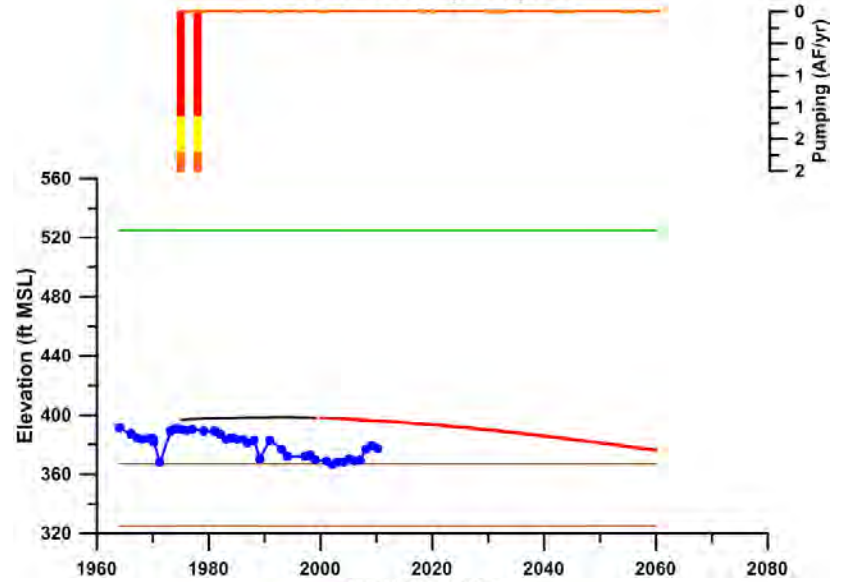

Well 6855407
Wilson County - Layer 5

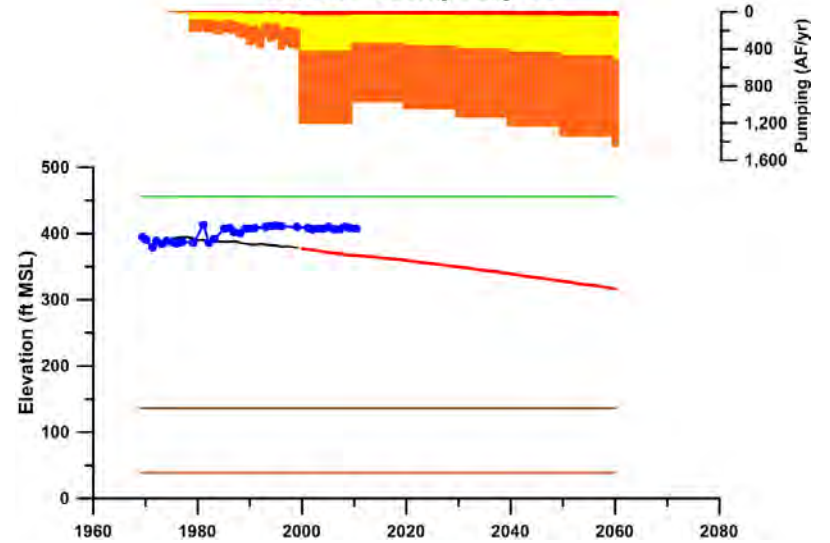

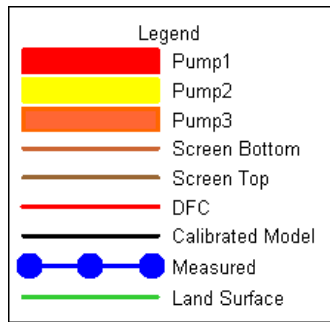

**Well 6855704
Wilson County - Layer 5**

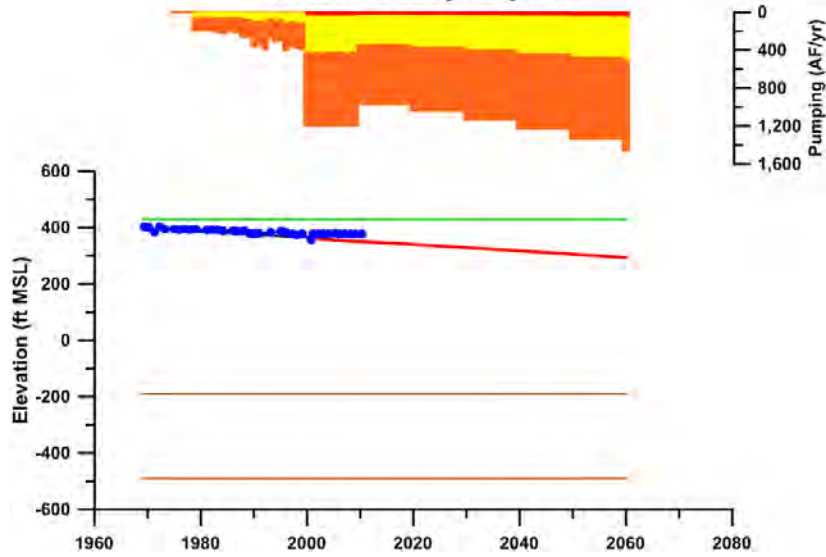

**Well 6856101
Wilson County - Layer 5**

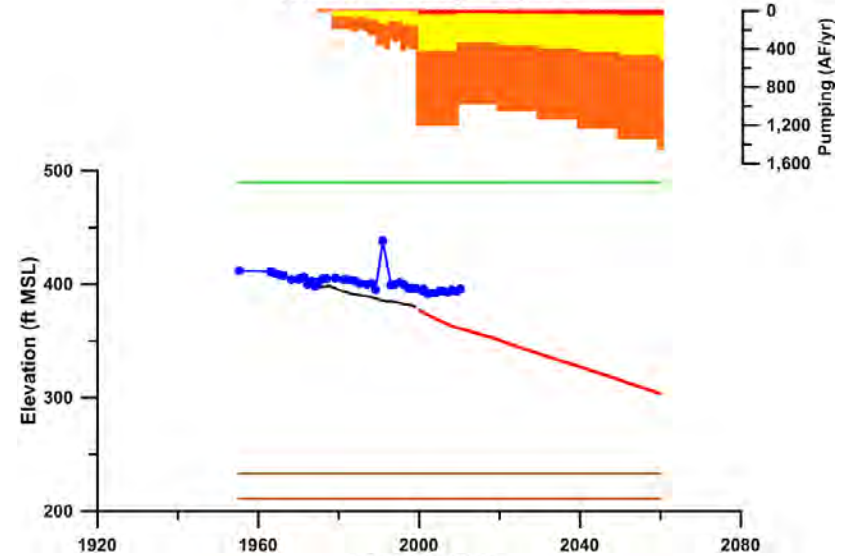

**Well 6856201
Wilson County - Layer 5**

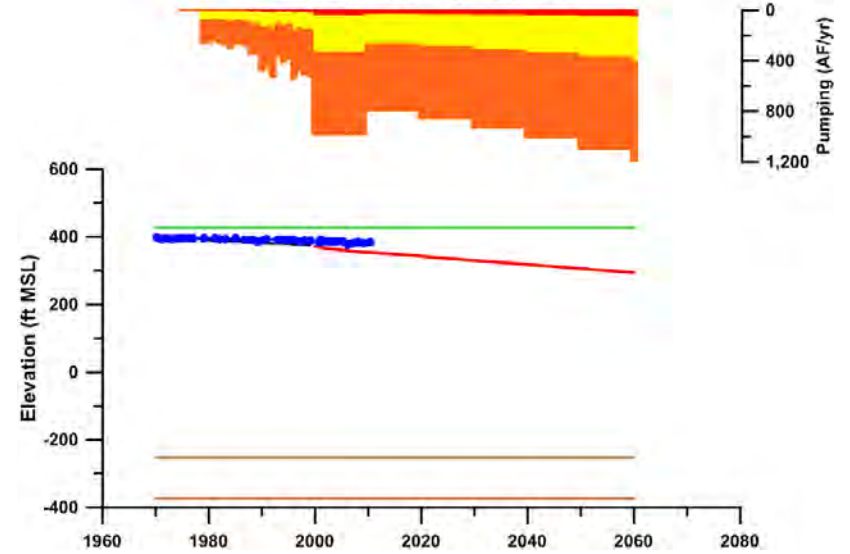

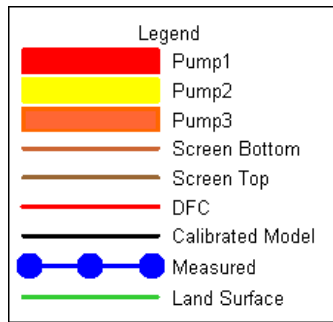

Well 6856302
Wilson County - Layer 5

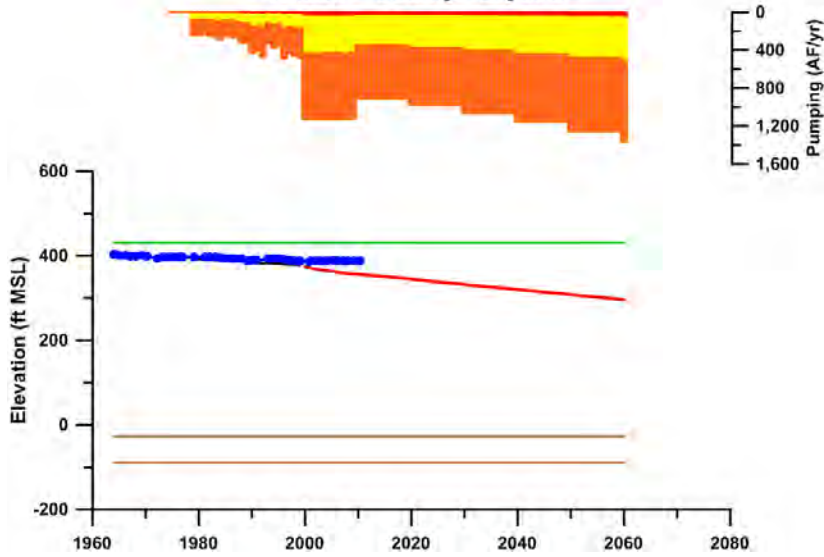

Well 6856804
Wilson County - Layer 3

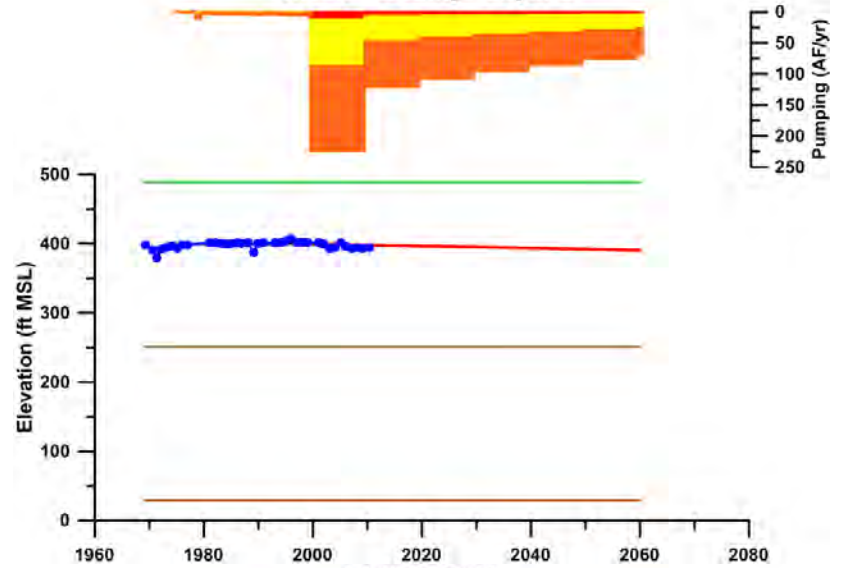

Well 6862104
Wilson County - Layer 5

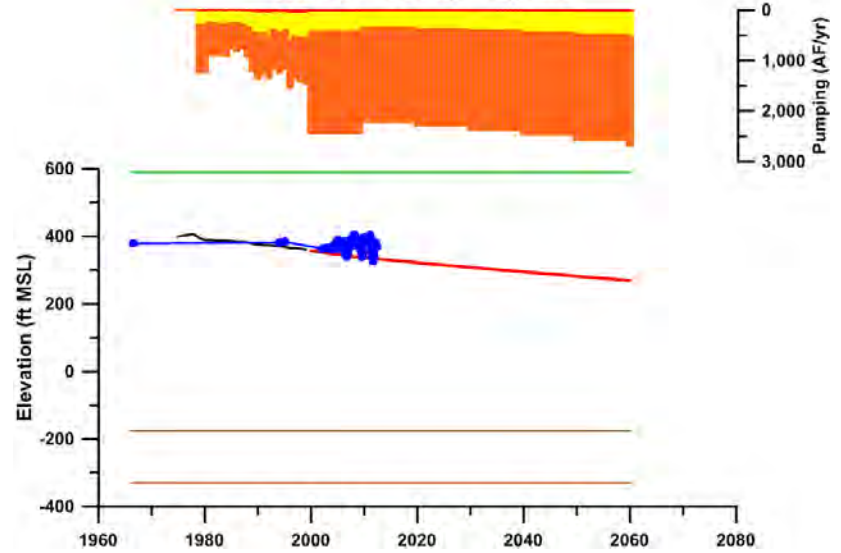

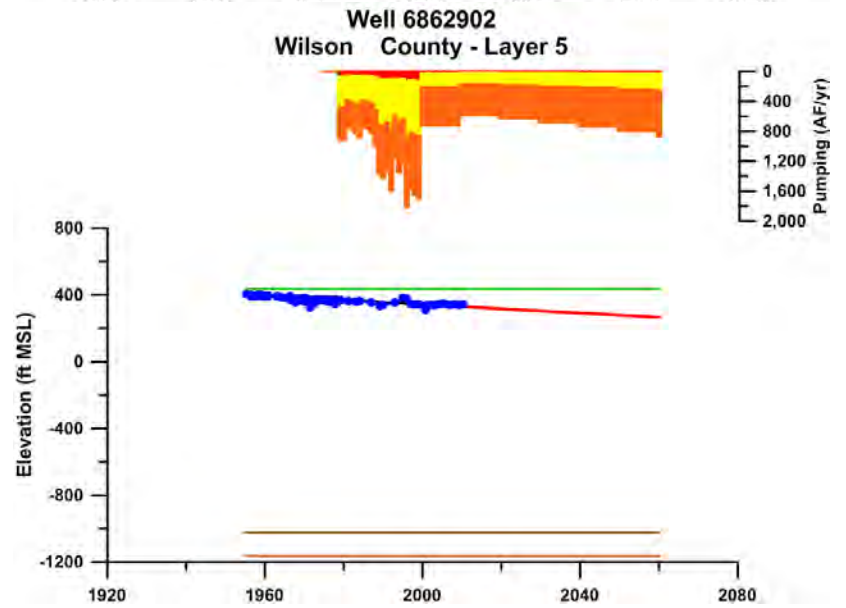
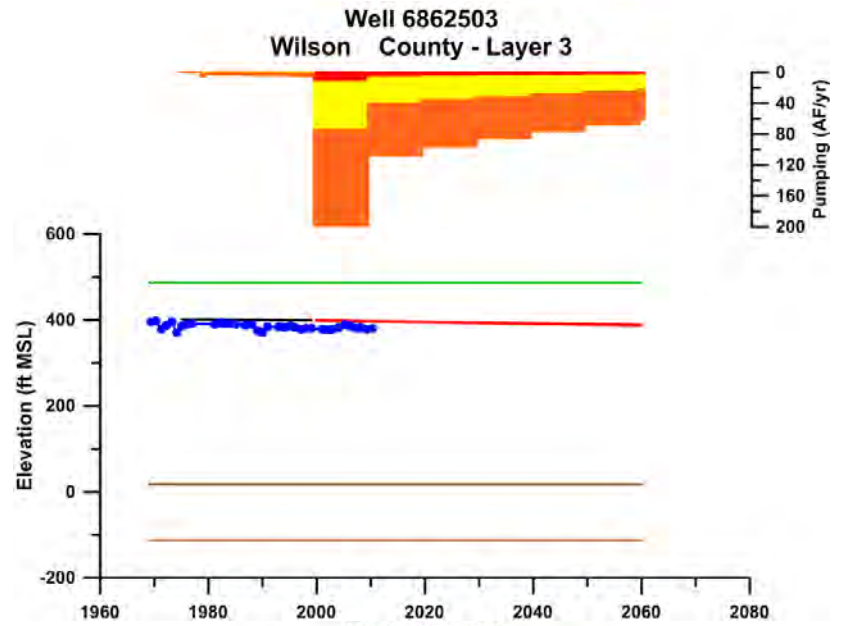
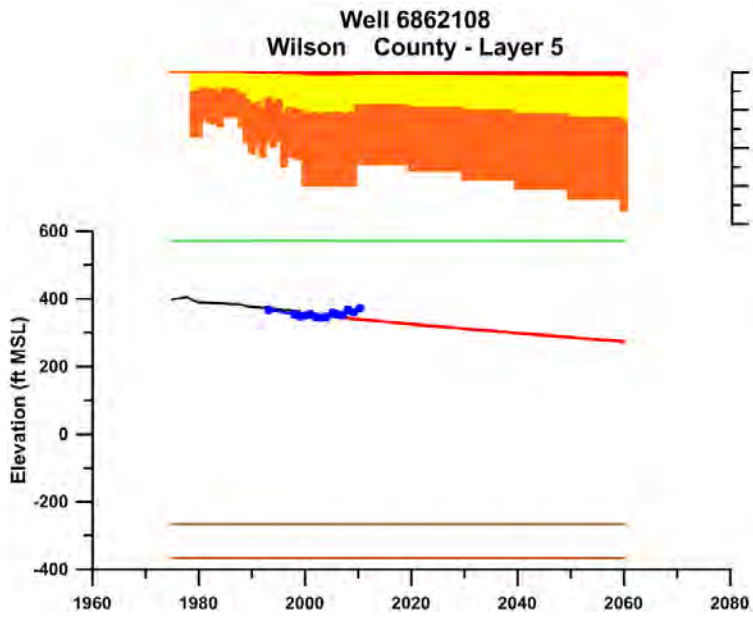
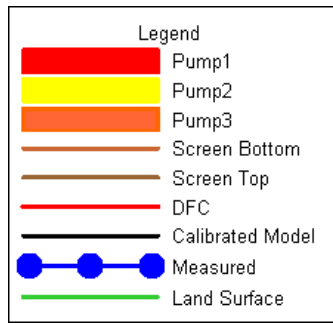

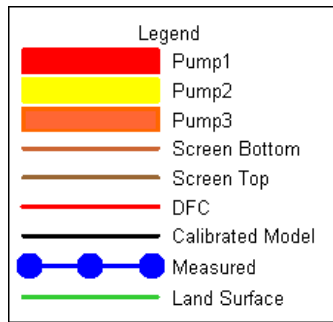

Well 6862906
Wilson County - Layer 5

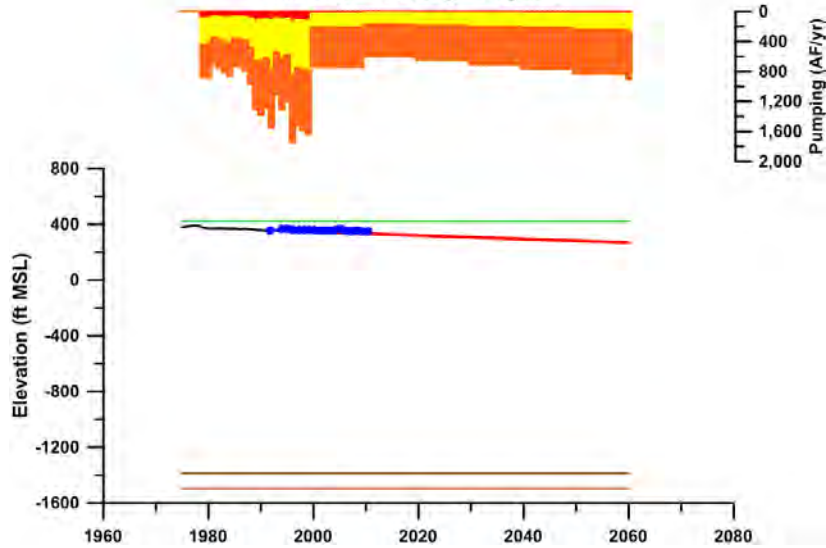

Well 6863101
Wilson County - Layer 5

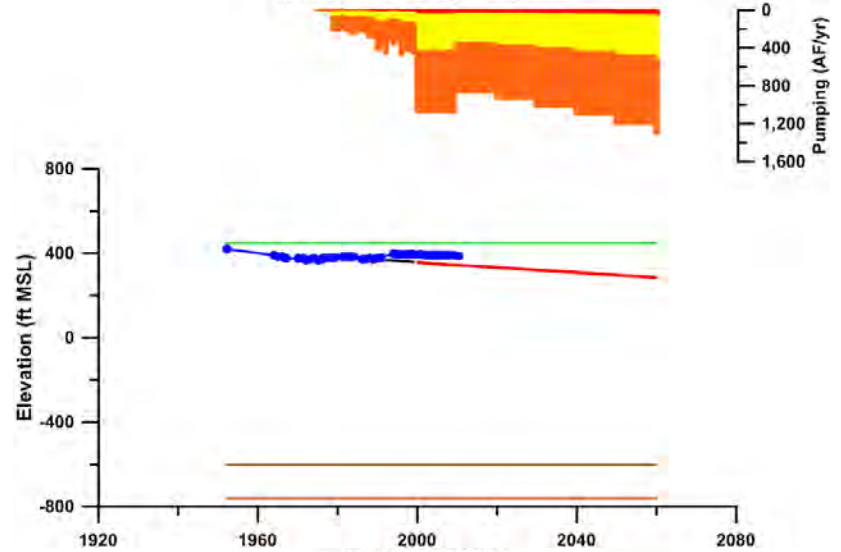

Well 6864402
Wilson County - Layer 5

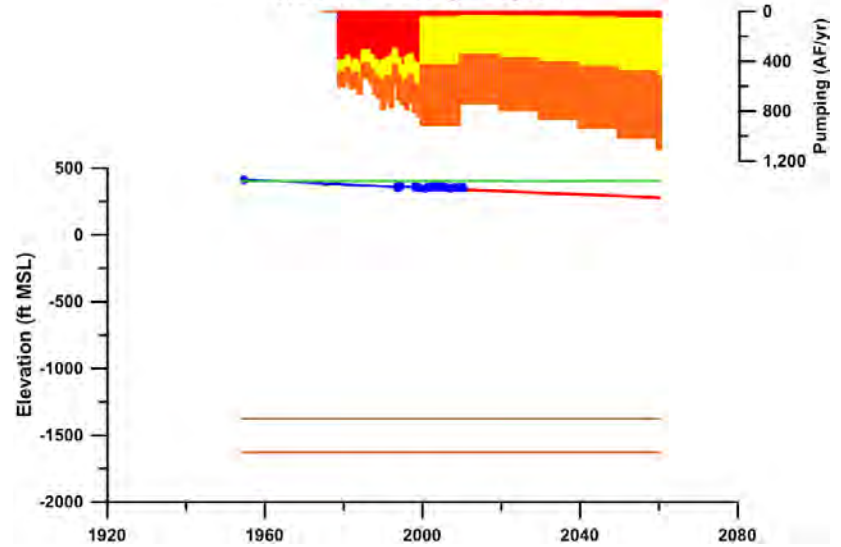

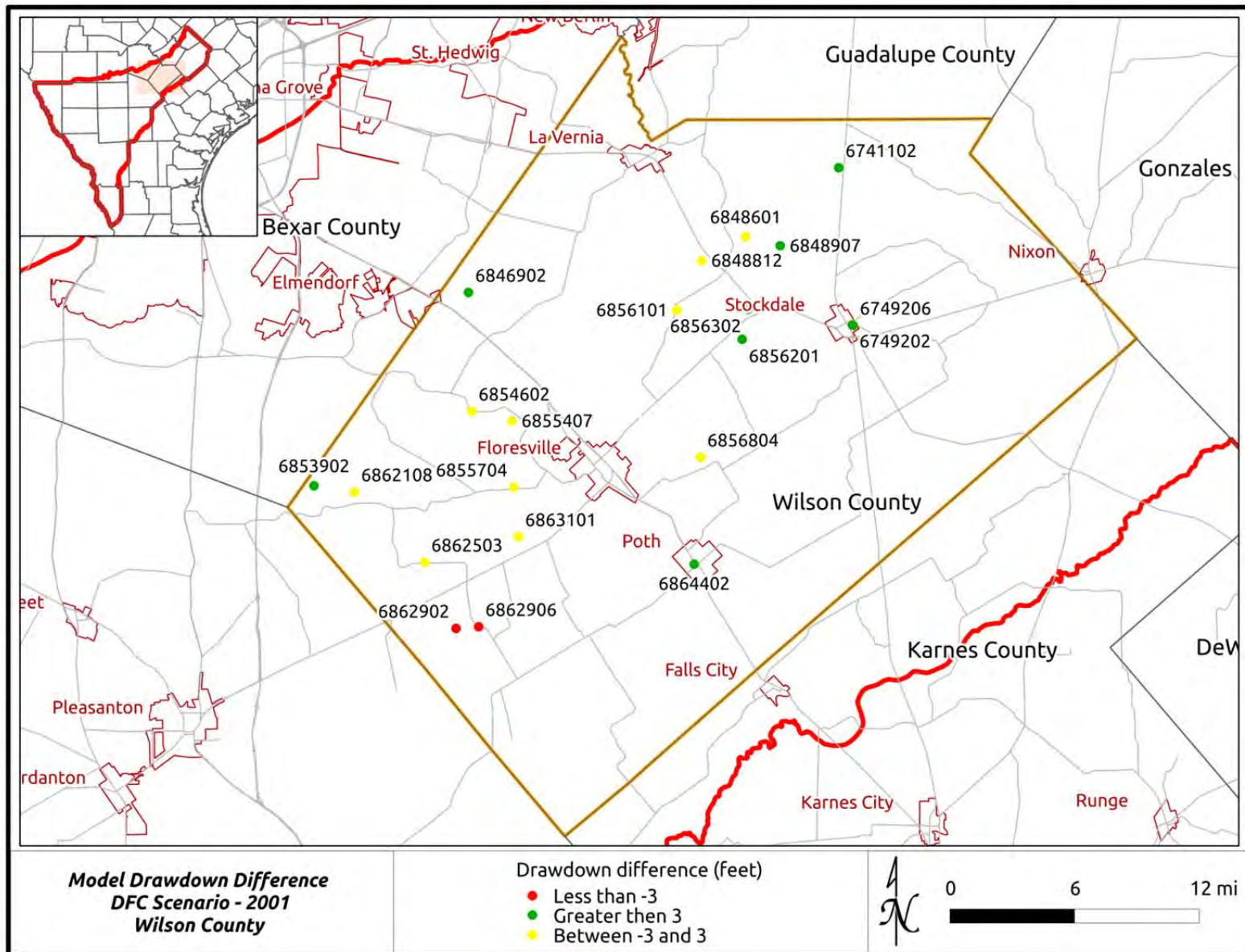

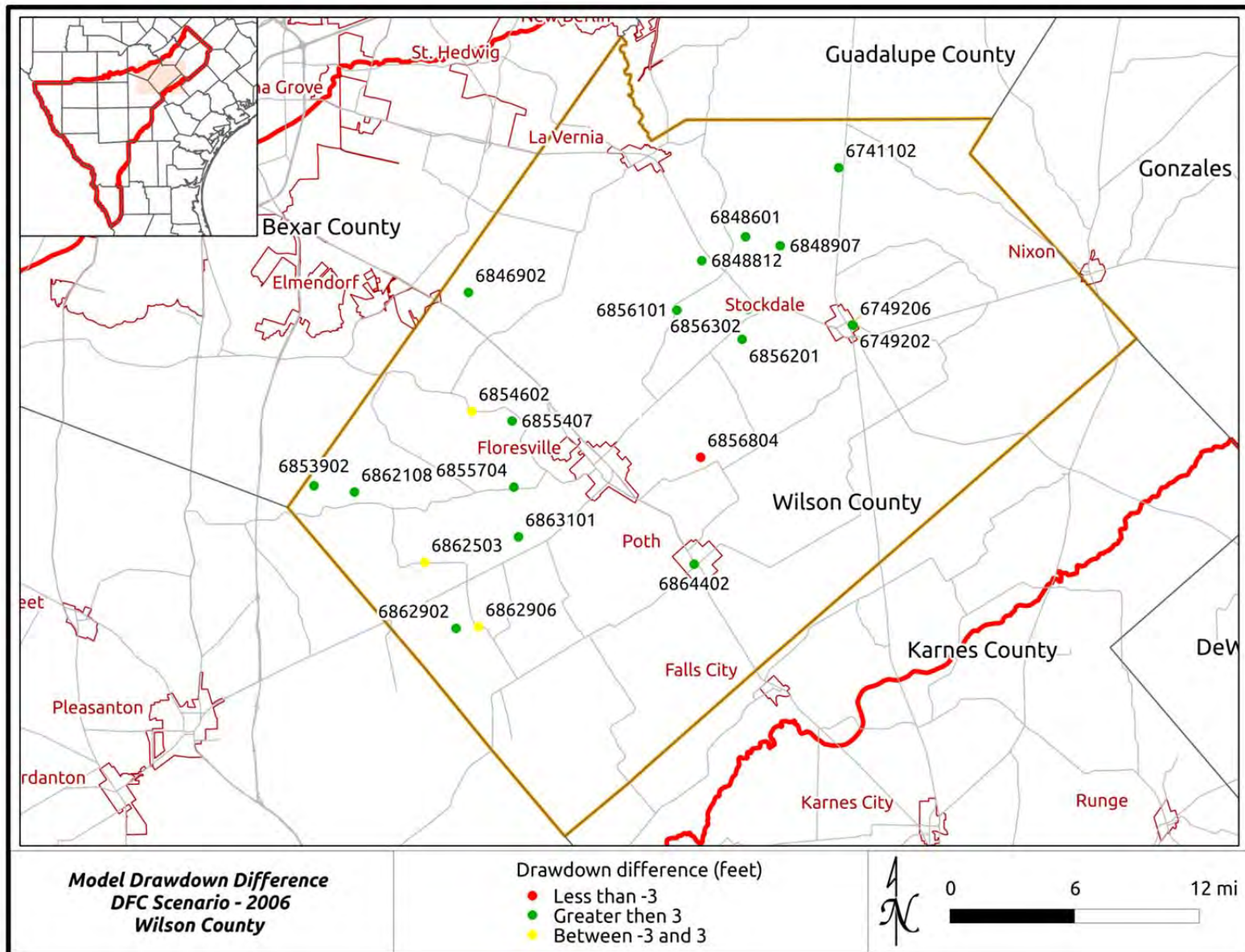

Summary of Drawdown Comparisons - Wilson County

<i>Column 1</i>	<i>Column 2</i>	<i>Column 3</i>	<i>Column 4</i>	<i>Column 5</i>	<i>Column 6</i>	<i>Column 7</i>
Year	Precipitation (% Avg)	County-Wide Average DFC	Number of Actual Drawdown Data Points	Average Actual Drawdown for Wells with Data	Average DFC for Wells with Data	Column 6 minus Column 5
2000	90	3.17	21	-0.27	2.35	2.62
2001	101	5.93	22	1.18	5.16	3.98
2002	113	8.31	22	0.44	7.42	6.98
2003	96	10.43	22	-0.40	9.38	9.79
2004	132	12.35	22	-4.50	11.18	15.68
2005	75	14.13	22	-0.81	12.87	13.68
2006	86	15.79	22	1.82	14.46	12.64
2007	142	17.34	22	-2.90	15.97	18.87
2008	74	18.82	22	0.49	17.42	16.93
2009	76	20.23	4	0.98	17.59	16.60
2010	132	21.28				
2011	45	22.44				

Wilson County - All Years

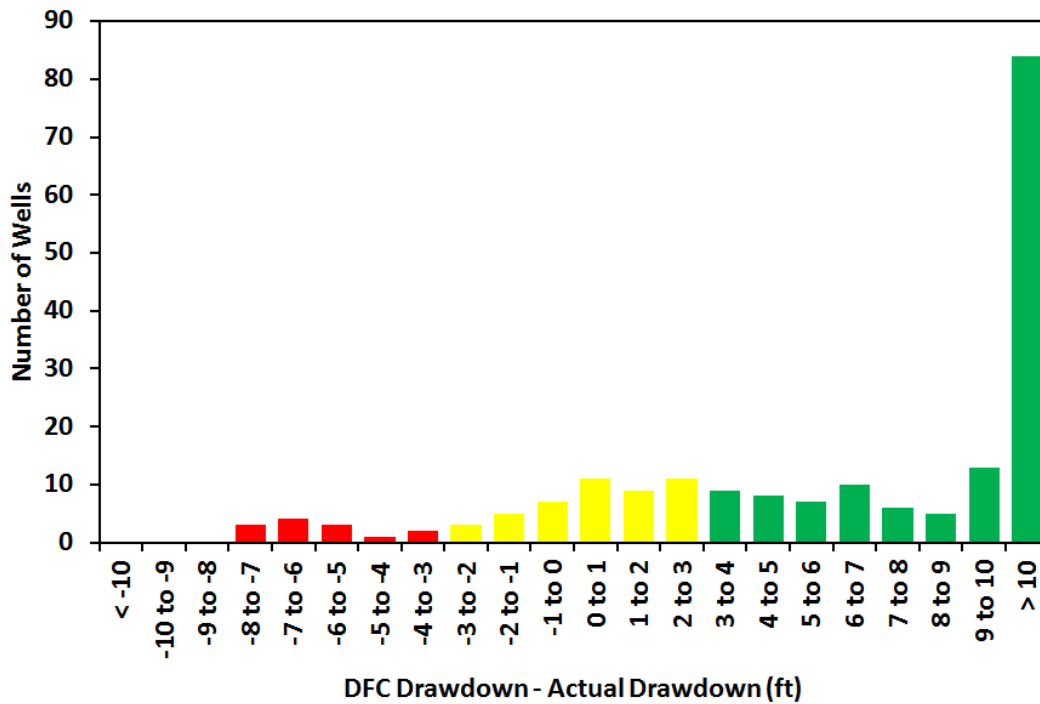

Wilson County

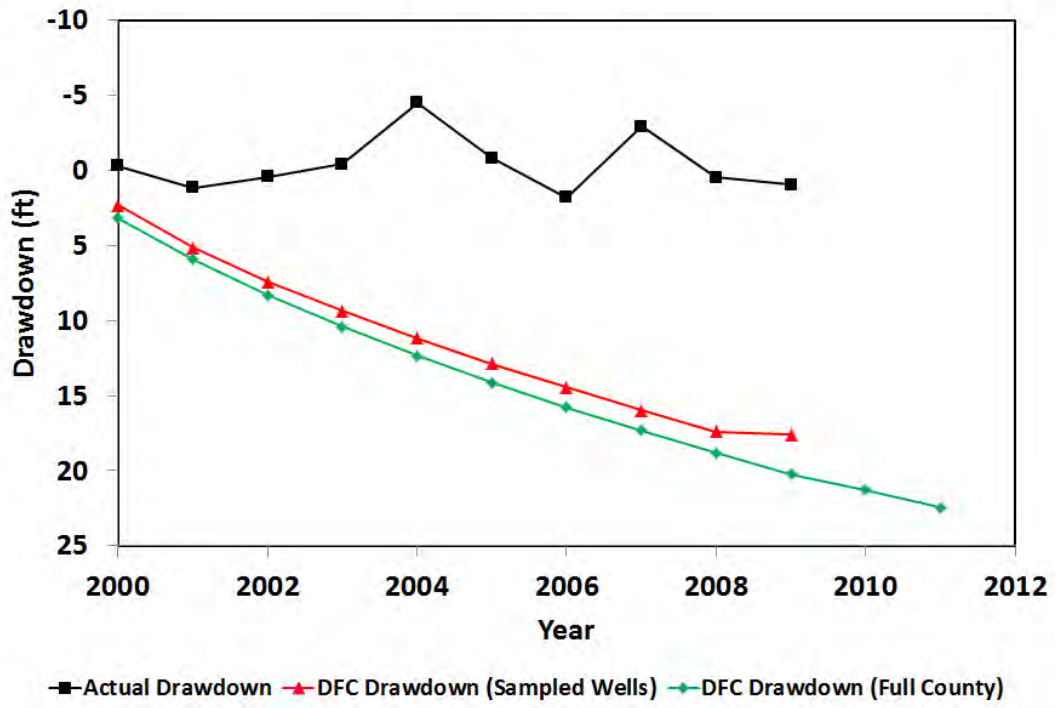

Appendix 15 – Zavala County

Location Map of Hydrograph Wells

Hydrographs

Note that pumping data are expressed in three zones:

- Pump 1 = pumping from cell where well is located
- Pump 2 = pumping in cells adjacent to Zone 1
- Pump 3 = pumping in cells adjacent to Zone 2

Screen Bottom and Screen Top = Elevation of Well Completion Interval

Land Surface = Elevation of Land Surface at Well

Groundwater Elevations

- Measured = Actual data from TWDB database
- Calibrated Model = Results for cell defined by well from calibrated model
- DFC = Results for cell defined by well from Scenario 4 of GAM Run 09-034

Drawdown Comparison Maps for 2001, 2006 and 2011

Summary of Drawdown Comparisons

Table analogous to Table 5 in text summarizing annual average drawdown (actual and DFC)

Histogram of Differences between DFC Drawdown and Actual Drawdown for All Years

Figure analogous to Figure 23 in text showing differences between actual drawdown and DFC conditions

Hydrograph of Actual Drawdown and DFC Drawdown

Figure analogous to Figure 26 in text showing time history of drawdown (actual and DFC) from 2000 to 2011

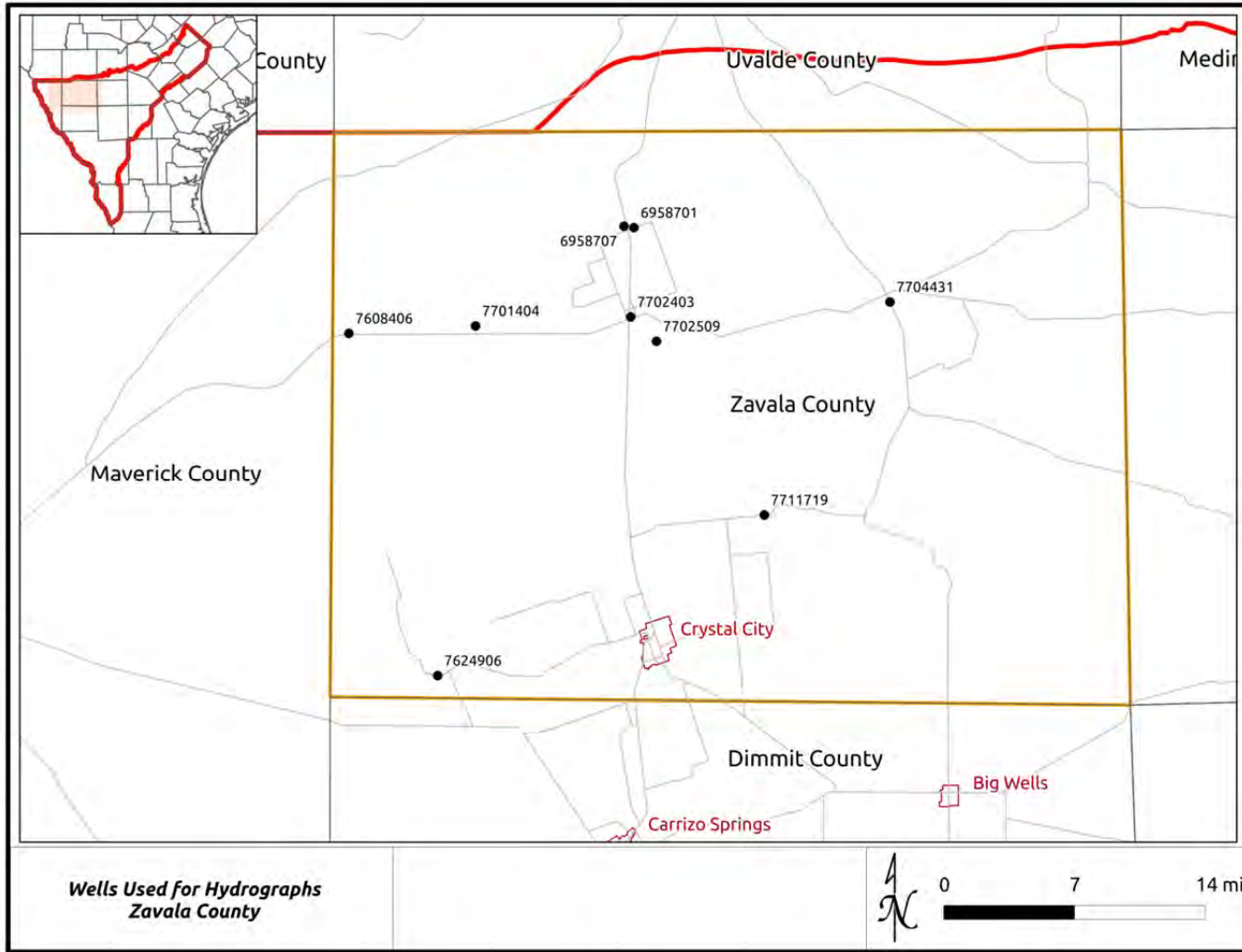

Location Map of Wells with Hydrographs – Zavala County

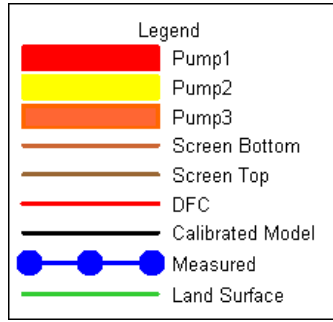

Well 6958701
Zavala County - Layer 5

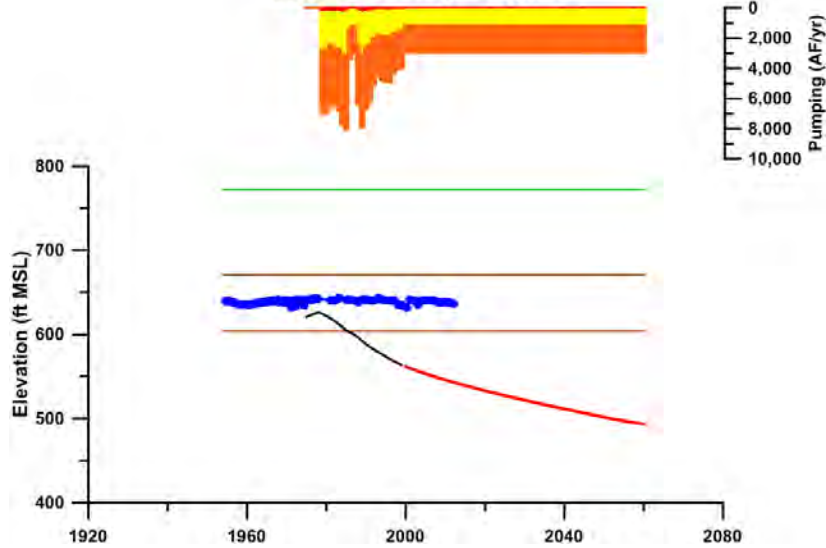

Well 6958707
Zavala County - Layer 5

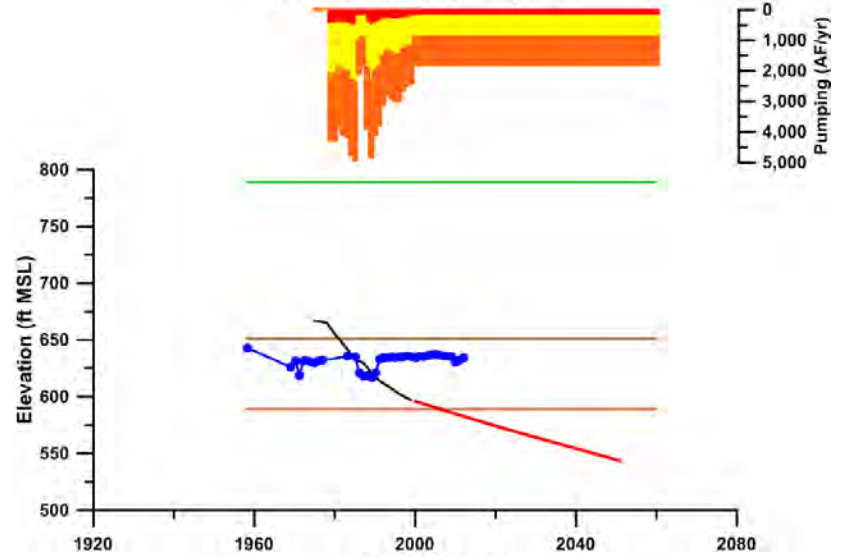

Well 7608406
Zavala County - Layer 5

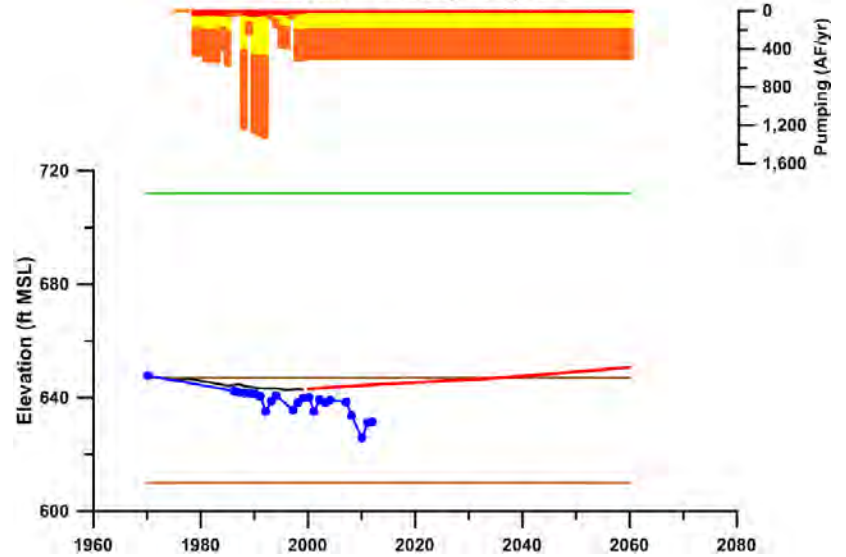

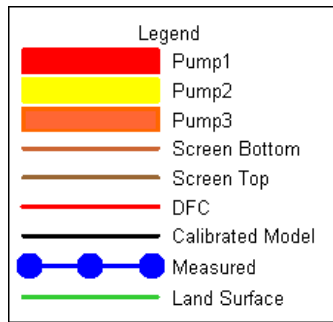

Well 7624906
Zavala County - Layer 5

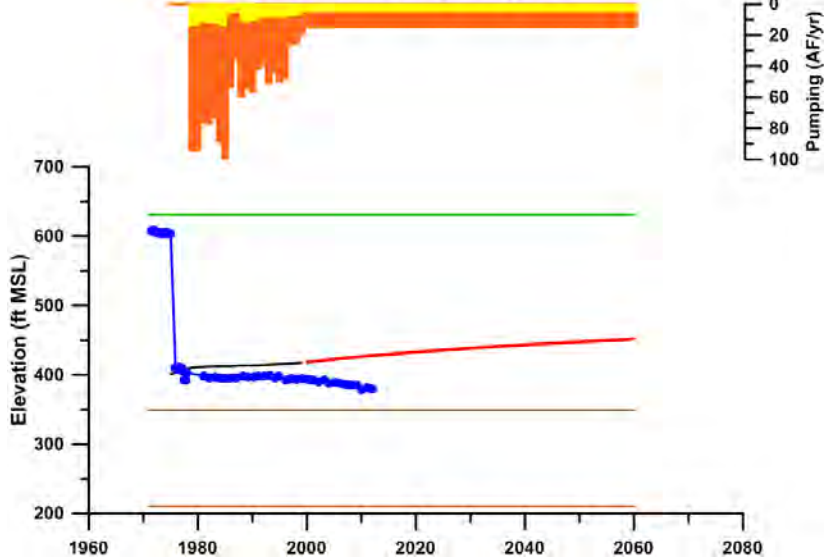

Well 7701404
Zavala County - Layer 5

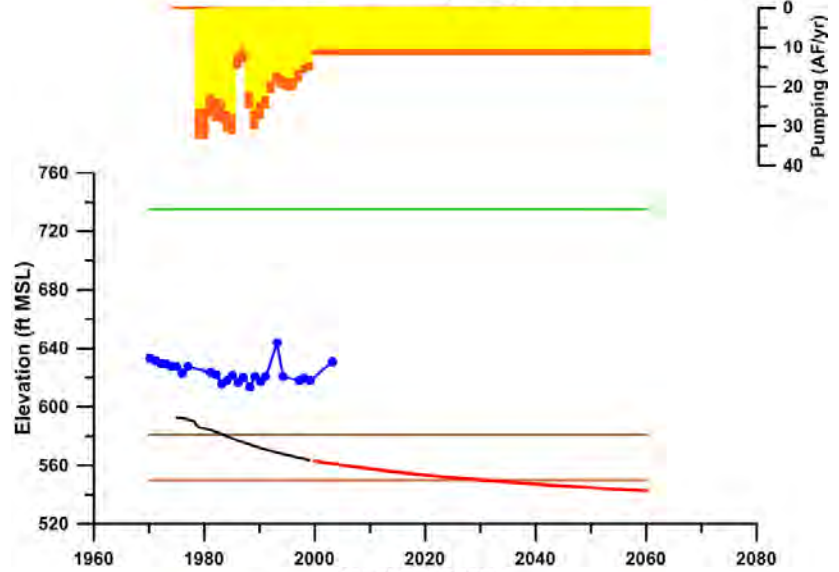

Well 7702403
Zavala County - Layer 5

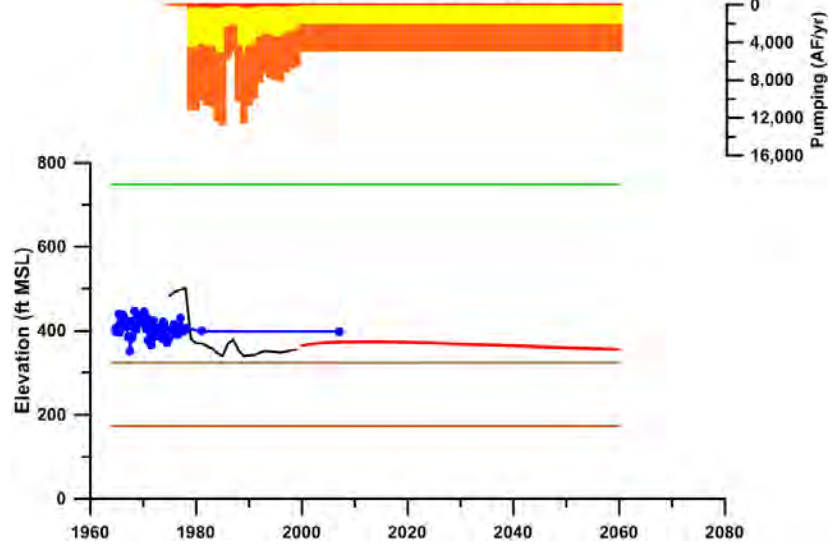

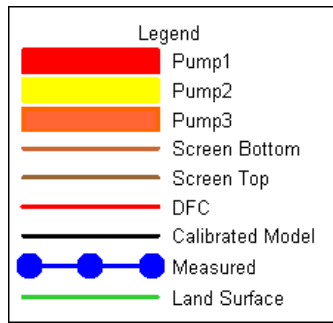

Well 7702509
Zavala County - Layer 5

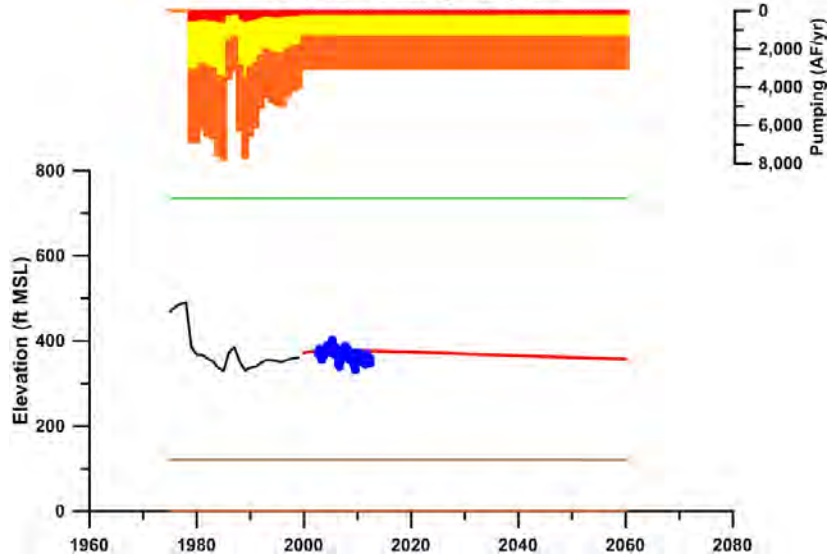

Well 7704431
Zavala County - Layer 5

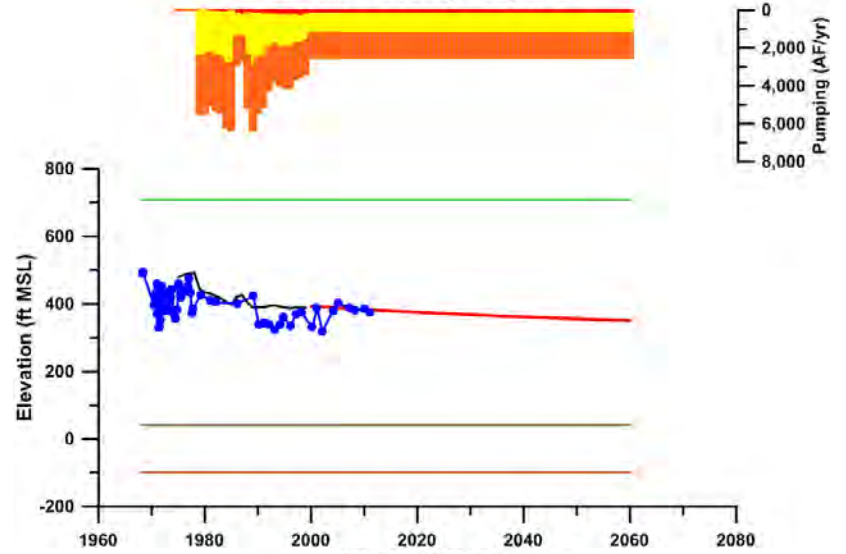

Well 7711719
Zavala County - Layer 4

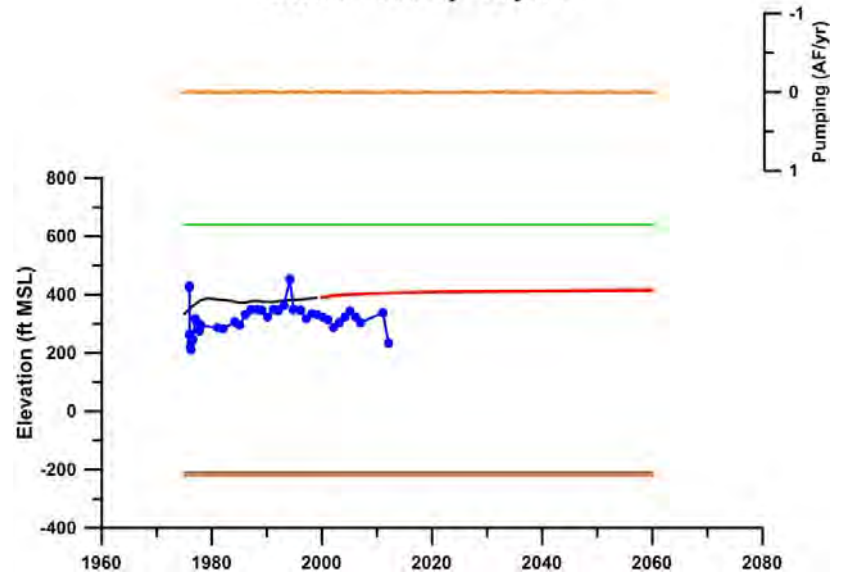

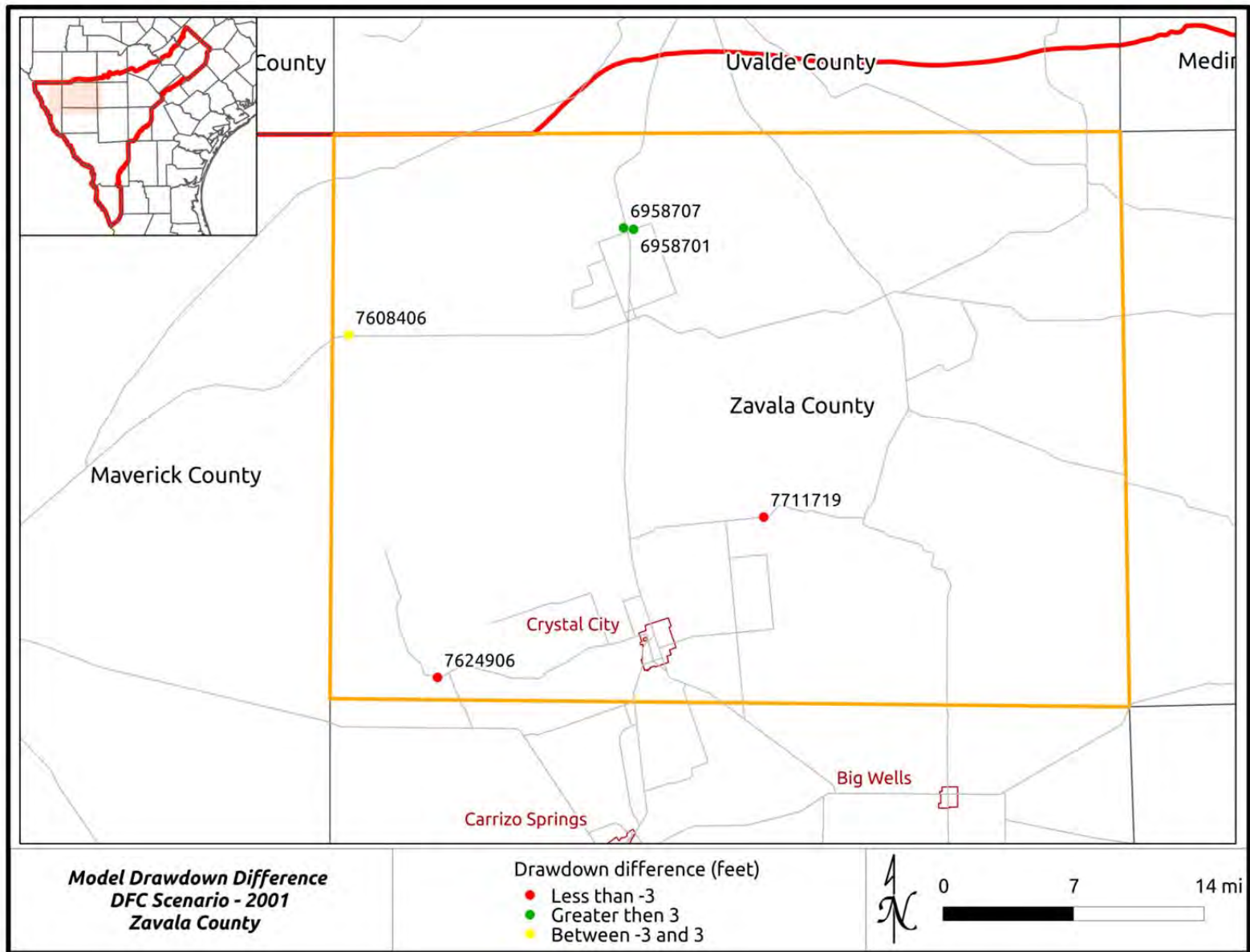

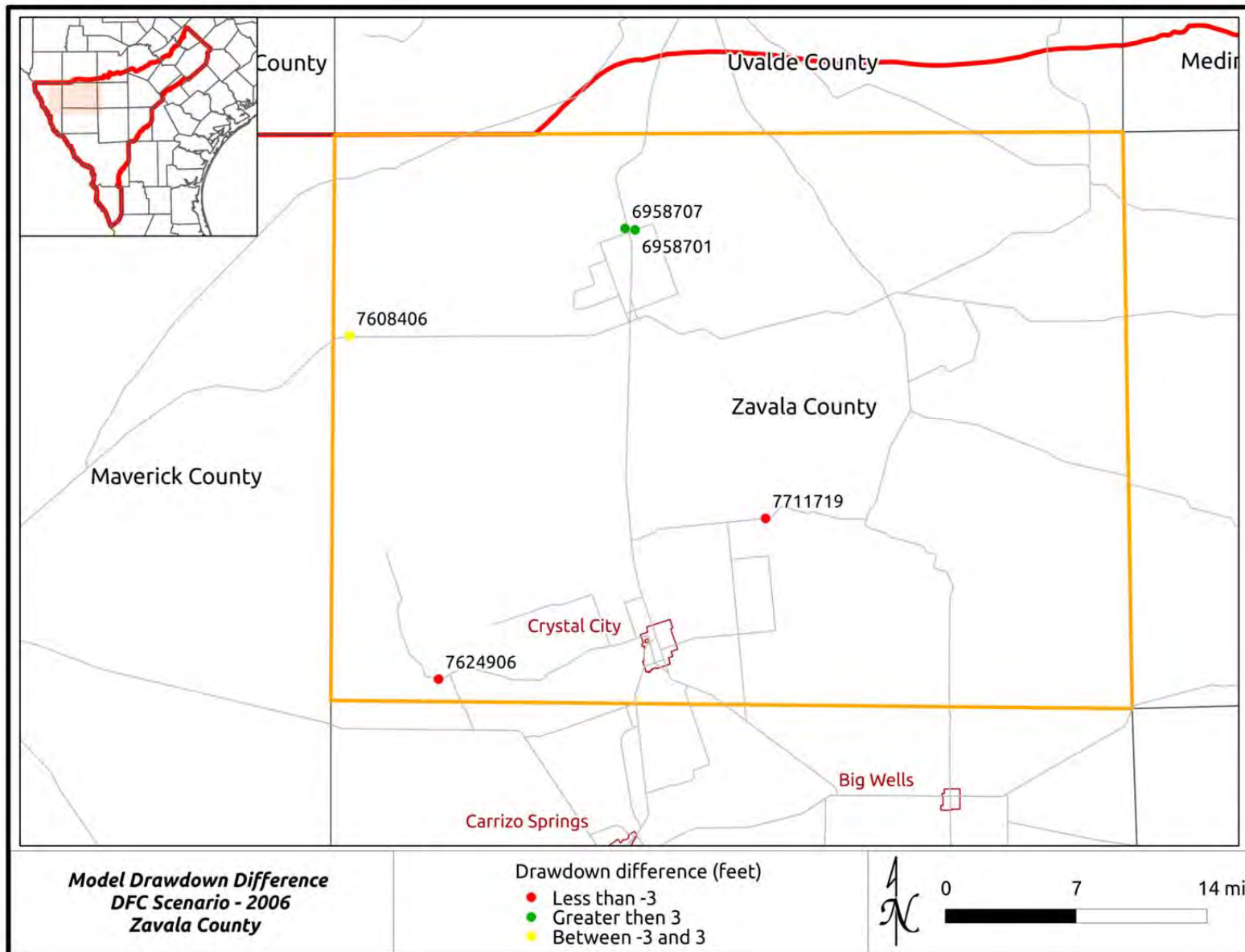

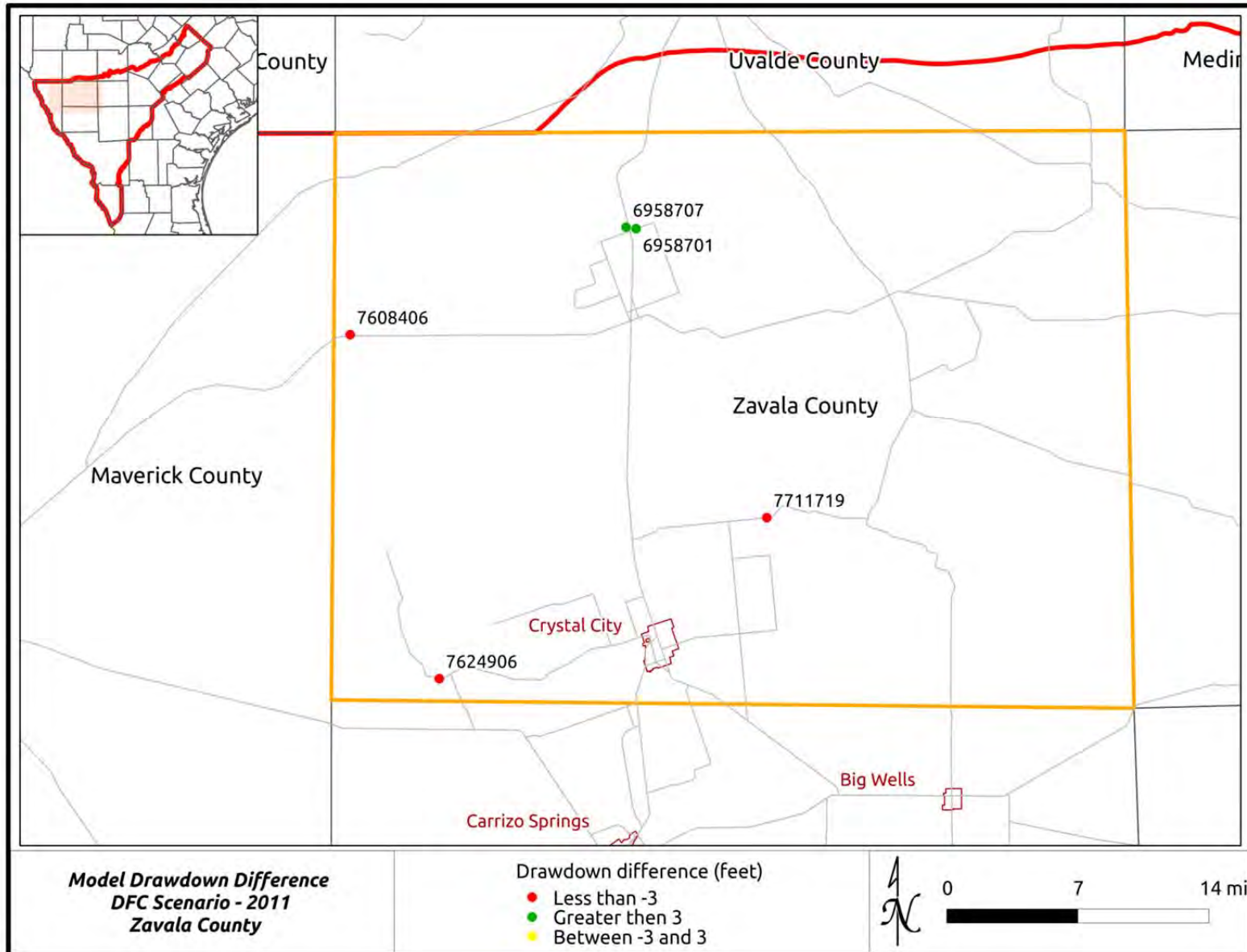

Summary of Drawdown Comparisons - Zavala County

<i>Column 1</i>	<i>Column 2</i>	<i>Column 3</i>	<i>Column 4</i>	<i>Column 5</i>	<i>Column 6</i>	<i>Column 7</i>
Year	Precipitation (% Avg)	County-Wide Average DFC	Number of Actual Drawdown Data Points	Average Actual Drawdown for Wells with Data	Average DFC for Wells with Data	Column 6 minus Column 5
2000	90	-1.86	5	0.60	-0.05	-0.65
2001	101	-2.88	5	6.18	-0.17	-6.35
2002	113	-3.58	6	0.42	0.11	-0.31
2003	96	-4.06	5	-1.13	-0.29	0.85
2004	132	-4.40	4	-7.26	-0.15	7.11
2005	75	-4.63	4	-1.39	-0.01	1.38
2006	86	-4.77	5	3.32	-0.05	-3.36
2007	142	-4.85	4	1.66	3.62	1.97
2008	74	-4.87	3	0.62	5.78	5.15
2009	76	-4.85	4	6.84	4.46	-2.38
2010	132	-5.17	5	0.43	0.73	0.30
2011	45	-5.54	5	21.30	0.96	-20.34

Zavala County - All Years

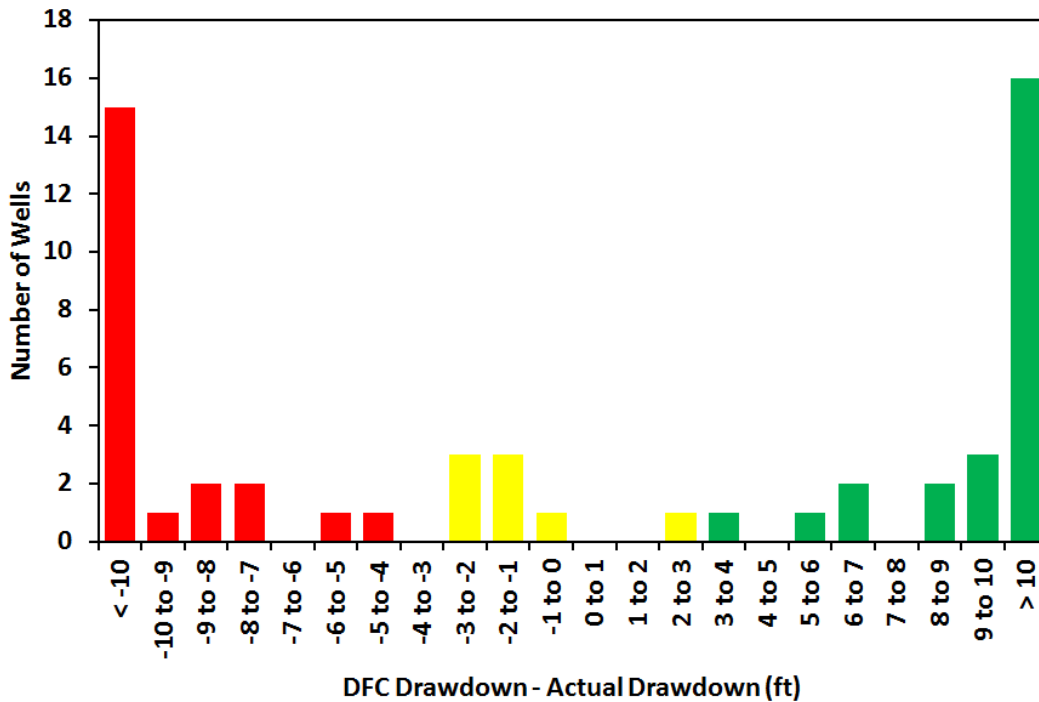

Zavala County

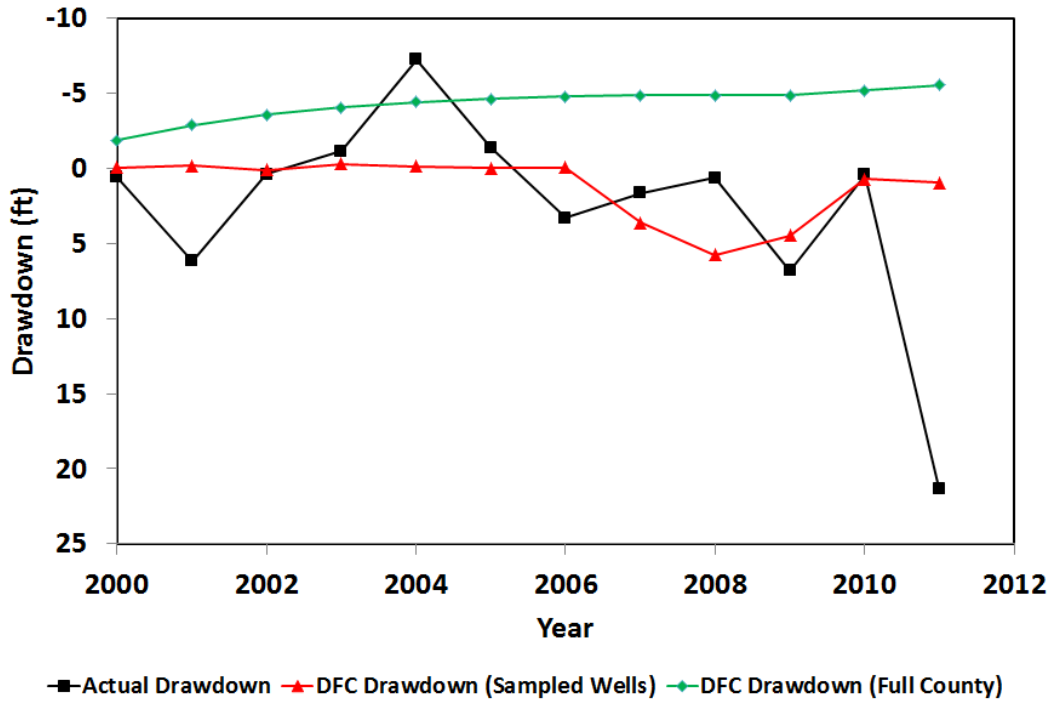

Appendix 16 – Responses to Comments from Draft Report dated December 21, 2012

Email from Jay Troell on February 13, 2013 containing 11 numbered comments.

Forwarded email from Louis Rosenberg on February 14, 2013 with comments from James Bene and a summary of the comment from Mr. Rosenberg.

Comments from Jay Troell, Larry Fox and Arthur Troell

1. Why do the numbers on Table 2, page 9 differ from Scenario 4 of GAM Run 09-034 since Table 2 is supposedly from Scenario 4 of GAM Run 09-034?

Table 5 from GAM Run 09-034 that summarized the drawdowns from Scenario 4 is presented below:

Groundwater Management Area 13 drawdowns in feet - scenario 4										
County	Sparta	Weches	Queen	Reklaw	Carizo	Layer 6	Layer 7	Layer 8	Wixox	Overall
	City									Overall
Atascosa	10	13	15	43	74	74	85	145	102	62
Bexar	0	0	0	8	64	48	37	138	94	90
Caldwell	0	0	5	16	97	93	52	66	64	63
Dimmit	-2	3	-4	-14	-17	-17	-22	-18	-19	-15
Frio	4	3	-3	19	39	38	31	35	35	24
Gonzales	21	26	32	60	94	94	88	82	88	65
Guadalupe	0	0	-11	5	54	52	20	31	30	32
Karnes	17	27	34	60	85	85	61	88	78	57
La Salle	7	8	9	11	12	12	-1	-9	1	6
Maverick	0	0	0	1	-8	-12	-11	-3	-7	-7
McMullen	25	29	32	39	45	44	12	9	22	29
Medina	0	0	0	-1	29	29	28	28	28	28
Uvalde	0	0	0	0	1	0	12	30	22	19
Webb	-7	-4	-9	-5	-4	-3	-1	-3	-2	-4
Wilson	7	13	13	43	75	75	78	153	102	68
Zavala	-7	-5	-13	-14	2	0	-5	-3	-3	-5
Overall	9	11	7	17	31	31	25	38	31	23

Table 2, page 9 from this report is presented below:

County	Layer 1	Layer 2	Layer 3	Layer 4	Layer 5	Layer 6	Layer 7	Layer 8	GMA 13
Atascosa	10	13	15	43	74	74	85	145	62
Bexar				8	64	48	37	136	90
Caldwell			5	16	96	92	51	65	63
Dimmit	-2	3	-4	-14	-17	-17	-22	-18	-15
Frio	4	3	-3	19	39	38	31	35	24
Gonzales	21	26	32	60	94	94	88	81	65
Guadalupe			-13	5	52	50	20	31	31
Karnes	17	27	34	60	86	85	61	88	57
LaSalle	7	8	9	11	12	12	-1	-9	6
Maverick				1	-8	-12	-11	-3	-7
McMullen	25	29	32	39	45	44	12	9	29
Medina				-1	29	29	28	28	28
Uvalde					1	3	12	30	19
Webb	-7	-4	-9	-5	-4	-3	-1	-3	-4
Wilson	7	13	13	43	75	75	78	153	68
Zavala	-7	-5	-13	-14	2	0	-5	-3	-5
GMA13	9	11	7	17	31	31	25	38	23

The biggest difference in these tables is that GAM Run 09-034 did not account for county-layer splits that had no active cells in the model (please see discussion in the report on page 8 and Table 1). GAM Run 09-034 used a default value of zero drawdown and this report simply

reported blank values when there were no active cells.

Individual differences in the tables are summarized below, with the drawdown value from GAM Run 09-034 reported first, and the drawdown value from this report presented second:

- Caldwell County, Layer 5 (97 vs. 96)
- Guadalupe County, Layer 5 (54 vs. 52)
- Karnes County, Layer 5 (85 vs. 86)
- Caldwell County, Layer 6 (93 vs. 92)
- Guadalupe County, Layer 6 (52 vs. 50)
- Uvalde County, Layer 6 (0 vs. 3)
- Caldwell County, Layer 7 (52 vs. 51)
- Gonzales County, Layer 8 (82 vs. 81)
- Guadalupe County, GMA 13 (32 vs. 31)

In most cases, the difference is a foot. Two of the differences are two feet, and one is three feet. The method used to develop the estimates in GAM Run 09-034 was different than that used to develop the table in this report. Rounding error and the fact that different methods were used are the reasons for these slight differences.

It would be helpful for the reader to define/label the “Layers” in Table 1 and Table 2, i.e. Layer 1 (Sparta Aquifer), Layer 2 (Weches Formation), Layer 3 (Queen City Aquifer), Layer 4 (Reklaw Formation), Layer 5 (Carrizo Aquifer), Layer 6 (upper Wilcox Aquifer), Layer 7 (middle Wilcox Aquifer), Layer 8 (lower Wilcox Aquifer).

The reason that I simply reported the layer number and did not attach a name to the layer was addressed at the November 15, 2012 GMA 13 meeting. I presented a series of slides at that meeting that compared the well completions (screen top and bottom elevation) that defined what layer the wells were located in with the TWDB assignment of aquifer units. Assuming that the TWDB aquifer designations are accurate, this analysis suggests that the model layering did not always honor the stratigraphy. Alternatively, if the model layers are assumed accurate, then the TWDB aquifer designations have errors. Although the possibility of some errors in the TWDB aquifer designations are likely, it is more likely that the model layers do not always accurately honor the stratigraphy.

2. Figure 5, page 10 shows pumping of about 70,000 AF/yr for Atascosa County in 2000 and 80,000 AF/yr in 2060. Please explain why the increase will be only 10,000 AF/yr.

All pumping changes were specified by the groundwater conservation districts in GMA 13 during the development of the DFC.

3. The largest draw-down will occur in northern Atascosa of 110 ft. From 2000 to 2060 northern Atascosa County and Bexar County will be highly pumped areas so why are Carrizo well data on either side of SAWS ASR unit not being used? The

only monitor well in Bexar County is a Wilcox well at Elmendorf.

4. Utilizing only 11 monitor wells in Atascosa County which covers over 1200 sq. miles seems way too few. Aren't more wells available? The Evergreen is monitoring at least 83 wells in the district, and should have more than 11 in Atascosa County.

Monitoring well data at San Miguel Electric Power Plant should be included.

These comments all involve the omission of specific wells or the number of wells in general. This effort was limited to data contained within the TWDB database in order to provide a consistent, reliable, and publically available set of data to evaluate DFCs. Moreover, in order to complete the task of comparing monitoring data to DFC drawdowns, it was necessary to further constrain the data set to wells that had a measurement in late 1999 or early 2000 to provide a basis for a drawdown calculation that were consistent with the DFC.

There are other wells that could be used by individual groundwater conservation districts to advance their own groundwater management objectives. However, the scope of this effort was specific to TWDB database wells with the constraint on the existence of a measurement in late 1999 or early 2000. The overall approach was designed to use data that were available. Future efforts to expand the monitoring network to include more wells are needed and should be developed by individual districts.

5. Map scale: rather than use 1-inch ≈ 10 miles in your maps why not use a scale of 1:16000 (1-inch ≈ 3 miles) for better readability for those who need to drill wells, etc.

The maps were intended to show the distribution of wells used in the analysis and summarize the results. The maps and this analysis are not suitable for identifying new well locations.

6. For evaluation of your model runs please show the pumping volume input data and assumptions, an example table is included on the last two pages. Input data for Carrizo and Wilcox should be shown separately.

The model runs were completed as part of the DFC development process, not as part of this effort. Table 5 in GAM Run 09-034 (shown below) has a breakdown of the pumping in 2060 by county and model layer. Decadal totals for each county can be seen in Figure 4 to 20 of this report. The detail that is suggested is beyond the scope of this effort, and the ability to breakdown pumping by type of use is generally not possible from the data in GAM Run 09-034. Future efforts may well include this level of detail, if the committee members decide to break the pumping down in this manner.

Table 5. Groundwater Management Area 13 pumpage in acre-feet per year used in model - scenario 4

County	Sparta	Queen City	Canizo	Layer 6	Layer 7	Layer 8	Total
Atascosa	994	4,202	58,308	250	250	17,000	81,004
Bexar	0	0	9,107	0	0	17,000	26,107
Caldwell	0	307	22,809	0	7,372	13,441	43,929
Dimmit	0	0	2,188	991	142	38	3,359
Frio	601	3,983	70,030	0	0	0	74,614
Gonzales	3,552	5,065	50,121	0	9,577	16,272	84,587
Guadalupe	0	0	9,500	0	2,994	1,549	14,043
Karnes (GMA 13)	0	0	1,280	0	0	0	1,280
Karnes (GMA 15)	0	0	801	0	0	0	801
La Salle	987	1	4,263	1,852	189	50	7,442
Maverick	0	0	143	136	259	992	1,530
McMullen (GMA 13)	90	136	1,819	0	0	0	2,045
McMullen (GMA 16)	10	14	181	0	0	0	205
Medina	0	0	400	0	1,248	886	2,534
Uvalde	0	0	828	0	0	0	828
Webb	0	0	896	13	6	1	916
Wilson	140	845	27,549	125	121	17,000	45,780
Zavala	0	0	24,649	6,316	3,676	328	34,969
Total (GMA 13)	6,364	14,539	283,890	9,783	25,834	84,557	424,967

7. Recharge water. What is the basis for recharge: average value over what period? average value during the drought of record (worst case - i.e. 1950's)? last 10-years average? please explain how the "average" recharge is determined and if this is to be varied by year/decade or held constant over next 50 years?

What are the recharge values based on? When was the analysis done, how and by whom?

The first full paragraph in the Methods and Results section of GAM Run 09-034 referenced previous GAM runs for the DFC process for "details on parameters and assumptions". One of those referenced documents is GAM Run 08-43, which stated that the recharge rate is an average of historic estimates from 1981 to 1999. This is the calibration period of the model, and the "average" recharge that was used was the average of the recharge estimates from the calibrated model. This average recharge was held constant for the entire simulation on which the DFC is based, and that assumption was the subject of discussion at the GMA 13 meeting and in this report.

8. We need synoptic water level maps through time in addition to the 1935 Lonsdale map, 1965 USGS map, 2000, 2010, and modeled maps for 2020, 2030, 2040, 2050 and 2060.

This request is beyond the scope of this analysis. A map of Scenario 4 drawdown in layer 5 in

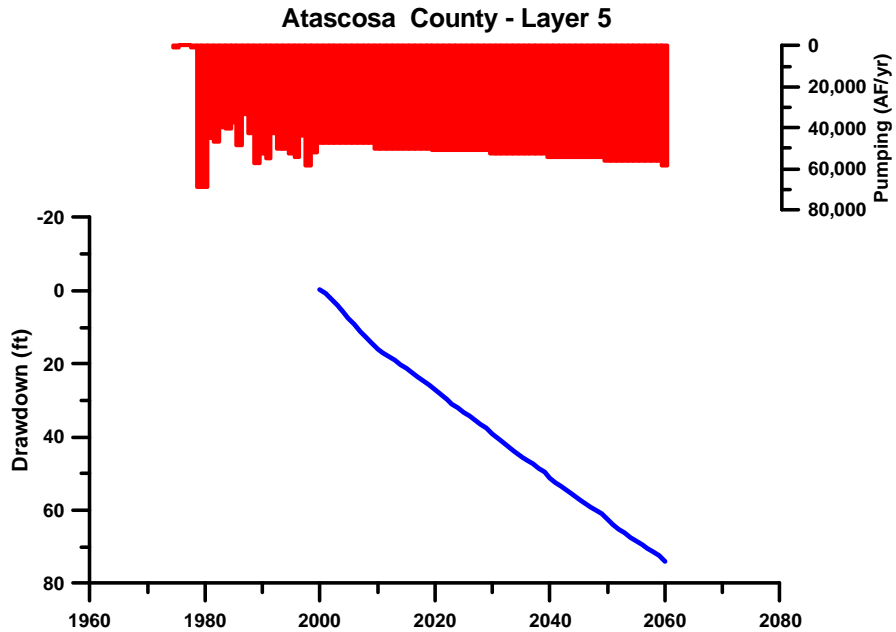

10. Does this report show where withdrawal of hydraulic fracturing water has increased draw-down more than originally predicted by GAM 09-034?

This report covers the model simulations that were completed in 2010 as part of the DFC process, and does not represent the recent increases to pumping for hydraulic fracturing operations. This has been a point of discussion at the GMA 13 meetings and has been identified as something that needs to be addressed in the current joint planning process.

11. More monitor wells need to be included for south Atascosa County (and other counties) where oil companies are drilling water wells for “fracking” operations.

Please see the response above regarding monitoring wells (comments 3 and 4).

Comments from Lou Rosenberg and James Bene

Mr. Rosenberg's comments summarizing Mr. Bene's comment:

DEVELOPING details, but not necessarily completed and sufficient upon which to make major, life defining decisions.

In polite terms, we have a distance to travel for greater courtroom reliability. But progress is in motion, however it is incomplete.

Mr. Bene's comments:

The general consensus is that generating written comments on the report wouldn't be meaningful or helpful at this time because the Board is going to ignore it anyway. My primary beef with the report is that it attempts to draw meaningful conclusions by comparing real-world water level measurements to DFC Scenario 4 model outputs, which is absurd because the pumpage in the model doesn't correspond to real-world pumpage. However, it sounded to me during the last meeting that Bill and everyone else now understands that in order to gage the model's performance over the last decade then real pumpage numbers need to be input. That's what they're working on now: the districts are compiling pumpage records and Bill will decipher their data, insert it into the model, and then make another report.

One of the objectives stated in the report was to “use the findings in the next round of joint planning (i.e. desired future condition development) to make the process more efficient, less costly, and more defensible.” This effort identified specific areas where the model simulations that will be used in the current round of joint planning can be improved (e.g. pumping from 2000 to present), and, thus, advance the stated objective.

Appendix D

Water Supply Needs and Water Management Strategies Data

**Table D-1. Groundwater Sources from 2012 State Water Plan for Counties within
Groundwater Management Area 13
(all values in acre-feet per year)**

County	Aquifer	2010	2020	2030	2040	2050	2060
Atascosa	Carrizo-Wilcox	47,806	47,806	47,806	47,806	47,806	47,806
Bexar	Carrizo-Wilcox	17,950	17,950	10,552	10,552	10,552	10,552
Caldwell	Carrizo-Wilcox	24,460	24,460	24,460	24,460	24,460	24,460
Dimmit	Carrizo-Wilcox	23,780	23,780	23,780	23,780	23,780	23,780
Frio	Carrizo-Wilcox	130,765	130,765	130,765	130,765	130,765	130,765
Gonzales	Carrizo-Wilcox	60,440	60,440	60,440	60,440	60,440	60,440
Guadalupe	Carrizo-Wilcox	12,583	12,583	12,583	12,583	12,583	12,583
Karnes	Carrizo-Wilcox	700	700	700	700	700	700
LaSalle	Carrizo-Wilcox	27,341	27,341	27,341	27,341	27,341	27,341
Maverick	Carrizo-Wilcox	2,066	2,066	2,066	2,066	2,066	2,066
McMullen	Carrizo-Wilcox	7,909	7,909	7,909	7,909	7,909	7,909
Medina	Carrizo-Wilcox	13,700	13,700	13,700	13,700	13,700	13,700
Uvalde	Carrizo-Wilcox	33,276	33,276	33,276	33,276	33,276	33,276
Webb	Carrizo-Wilcox	17,176	17,176	17,176	17,176	17,176	17,176
Wilson	Carrizo-Wilcox	21,802	21,802	21,802	21,802	21,802	21,802
Zavala	Carrizo-Wilcox	23,936	23,936	23,936	23,936	23,936	23,936
Atascosa	Queen City	4,380	4,380	4,380	4,380	4,380	4,380
Caldwell	Queen City	320	320	320	320	320	320
Frio	Queen City	7,999	7,999	7,999	7,999	7,999	7,999
Gonzales	Queen City	4,590	4,590	4,590	4,590	4,590	4,590
LaSalle	Queen City	330	330	330	330	330	330
McMullen	Queen City	1,105	1,105	1,105	1,105	1,105	1,105
Wilson	Queen City	5,650	5,650	5,650	5,650	5,650	5,650
Atascosa	Sparta	1,150	1,150	1,150	1,150	1,150	1,150
Frio	Sparta	1,260	1,260	1,260	1,260	1,260	1,260
Gonzales	Sparta	4,500	4,500	4,500	4,500	4,500	4,500
LaSalle	Sparta	1,100	1,100	1,100	1,100	1,100	1,100
McMullen	Sparta	600	600	600	600	600	600
Wilson	Sparta	980	980	980	980	980	980
Webb	Yegua-Jackson	5,000	5,000	5,000	5,000	5,000	5,000
Zapata	Yegua-Jackson	2,000	2,000	2,000	2,000	2,000	2,000
Total for All Counties and Aquifers		506,654	506,654	499,256	499,256	499,256	499,256

**Table D-2 Water Demands from the 2012 State Water Plan for Counties within
Groundwater Management Area 13
(all values in acre-feet per year)**

Page 1 of 5

ATASCOSA COUNTY						
MUNICIPAL	6,941	7,696	8,335	8,809	9,288	9,666
MANUFACTURING	6	6	6	6	6	6
MINING	1,298	1,370	1,405	1,439	1,472	1,509
STEAM ELECTRIC	7,000	4,807	6,101	5,997	7,336	7,672
LIVESTOCK	1,745	1,745	1,745	1,745	1,745	1,745
IRRIGATION	40,885	39,509	38,185	36,911	35,686	34,502
ATASCOSA COUNTY TOTAL	57,875	55,133	55,777	54,907	55,533	55,100

BEXAR COUNTY						
MUNICIPAL	262,106	290,071	316,423	336,033	355,245	374,536
MANUFACTURING	25,951	29,497	32,775	36,068	38,965	42,112
MINING	3,582	3,934	4,150	4,363	4,576	4,766
STEAM ELECTRIC	20,395	25,761	30,139	32,973	36,120	39,614
LIVESTOCK	1,319	1,319	1,319	1,319	1,319	1,319
IRRIGATION	15,273	14,628	14,010	13,417	12,850	12,306
BEXAR COUNTY TOTAL	328,626	365,210	398,816	424,173	449,075	474,653

CALDWELL COUNTY						
MUNICIPAL	6,306	7,898	9,222	10,555	11,926	13,328
MANUFACTURING	15	18	21	24	27	29
MINING	14	15	16	17	18	18
LIVESTOCK	918	918	918	918	918	918
IRRIGATION	1,044	928	824	733	651	578
CALDWELL COUNTY TOTAL	8,297	9,777	11,001	12,247	13,540	14,871

DIMITT COUNTY						
MUNICIPAL	2,561	2,692	2,756	2,725	2,652	2,523
MINING	1,003	1,034	1,051	1,067	1,082	1,095
LIVESTOCK	552	552	552	552	552	552
IRRIGATION	10,611	10,333	10,225	9,813	9,391	8,987
DIMITT COUNTY TOTAL	14,727	14,611	14,584	14,157	13,677	13,157

**Table D-2 Water Demands from the 2012 State Water Plan for Counties within
Groundwater Management Area 13
(all values in acre-feet per year)**

Page 2 of 5

FRIO COUNTY						
MUNICIPAL	3,402	3,668	3,890	4,061	4,202	4,287
MINING	109	104	102	100	98	96
STEAM ELECTRIC	289	268	201	192	76	91
LIVESTOCK	1,209	1,209	1,209	1,209	1,209	1,209
IRRIGATION	82,017	79,098	76,302	73,627	71,065	68,592
FRIO COUNTY TOTAL	87,026	84,347	81,704	79,189	76,650	74,275
GONZALES COUNTY						
MUNICIPAL	4,108	4,404	4,624	4,765	4,794	4,774
MANUFACTURING	2,400	2,628	2,822	3,011	3,177	3,402
MINING	28	27	26	25	24	24
LIVESTOCK	5,453	5,453	5,453	5,453	5,453	5,453
IRRIGATION	1,304	1,124	969	835	720	621
GONZALES COUNTY TOTAL	13,293	13,636	13,894	14,089	14,168	14,274
GUADALUPE COUNTY						
MUNICIPAL	17,113	21,167	25,595	29,907	34,980	40,533
MANUFACTURING	2,638	2,957	3,249	3,530	3,771	4,097
MINING	306	321	330	338	346	353
STEAM ELECTRIC	4,788	3,406	3,326	5,136	5,585	7,515
LIVESTOCK	1,057	1,057	1,057	1,057	1,057	1,057
IRRIGATION	1,070	955	846	742	710	705
GUADALUPE COUNTY TOTAL	26,972	29,863	34,403	40,710	46,449	54,260
KARNES COUNTY						
MUNICIPAL	2,927	3,190	3,465	3,679	3,822	3,909
MANUFACTURING	118	122	125	128	130	137
MINING	106	103	102	101	101	100
LIVESTOCK	1,185	1,185	1,185	1,185	1,185	1,185
IRRIGATION	1,382	1,250	1,131	1,023	925	836
KARNES COUNTY TOTAL	5,718	5,850	6,008	6,116	6,163	6,167

**Table D-2 Water Demands from the 2012 State Water Plan for Counties within
Groundwater Management Area 13
(all values in acre-feet per year)**

Page 3 of 5

LA SALLE COUNTY						
MUNICIPAL	1,799	1,946	2,058	2,162	2,262	2,350
LIVESTOCK	1,687	1,687	1,687	1,687	1,687	1,687
IRRIGATION	4,791	4,643	4,500	4,361	4,227	4,097
LA SALLE COUNTY TOTAL	8,277	8,276	8,245	8,210	8,176	8,134

MAVERICK COUNTY						
MUNICIPAL	9,409	10,559	11,666	12,649	13,601	14,476
MANUFACTURING	64	69	73	77	80	85
MINING	156	162	166	169	172	175
LIVESTOCK	260	260	260	260	260	260
IRRIGATION	95,040	91,693	87,863	87,863	87,863	87,863
MAVERICK COUNTY TOTAL	104,929	102,743	100,028	101,018	101,976	102,859

MCMULLEN COUNTY						
MUNICIPAL	186	190	180	168	160	152
MINING	195	203	207	211	215	218
LIVESTOCK	659	659	659	659	659	659
MCMULLEN COUNTY TOTAL	1,040	1,052	1,046	1,038	1,034	1,029

MEDINA COUNTY						
MUNICIPAL	7,576	8,660	9,656	10,509	11,395	12,234
MANUFACTURING	67	75	82	89	95	103
MINING	130	135	137	139	141	143
LIVESTOCK	1,298	1,298	1,298	1,298	1,298	1,298
IRRIGATION	54,450	52,179	50,005	47,922	45,927	44,015
MEDINA COUNTY TOTAL	63,521	62,347	61,178	59,957	58,856	57,793

**Table D-2 Water Demands from the 2012 State Water Plan for Counties within
Groundwater Management Area 13
(all values in acre-feet per year)**

Page 4 of 5

UVALDE COUNTY						
MUNICIPAL	8,066	8,394	8,652	8,846	8,964	9,099
MANUFACTURING	432	455	473	490	505	538
MINING	313	345	364	383	401	418
LIVESTOCK	1,284	1,284	1,284	1,284	1,284	1,284
IRRIGATION	55,791	53,609	51,513	49,498	47,563	45,703
UVALDE COUNTY TOTAL	65,886	64,087	62,286	60,501	58,717	57,042

WEBB COUNTY						
MUNICIPAL	54,855	69,401	86,001	104,503	124,614	146,420
MANUFACTURING	28	31	34	37	39	42
MINING	1,204	1,192	1,189	1,187	1,185	1,180
STEAM ELECTRIC	1,492	1,190	1,391	1,636	1,935	2,300
LIVESTOCK	1,513	1,513	1,513	1,513	1,513	1,513
IRRIGATION	20,507	19,548	18,654	18,654	18,654	18,654
WEBB COUNTY TOTAL	79,599	92,875	108,782	127,530	147,940	170,109

WILSON COUNTY						
MUNICIPAL	6,407	8,118	9,977	11,797	13,766	15,836
MANUFACTURING	1	1	1	1	1	1
MINING	242	234	229	225	221	218
LIVESTOCK	1,808	1,808	1,808	1,808	1,808	1,808
IRRIGATION	11,296	10,034	8,921	7,940	7,077	6,330
WILSON COUNTY TOTAL	19,754	20,195	20,936	21,771	22,873	24,193

ZAPATA COUNTY						
MUNICIPAL	2,265	2,531	2,793	3,033	3,267	3,448
MINING	24	23	23	23	23	23
LIVESTOCK	474	474	474	474	474	474
IRRIGATION	6,454	6,121	5,805	5,805	5,805	5,805
ZAPATA COUNTY TOTAL	9,217	9,149	9,095	9,335	9,569	9,750

**Table D-2 Water Demands from the 2012 State Water Plan for Counties within
Groundwater Management Area 13
(all values in acre-feet per year)
Page 5 of 5**

ZAVALA COUNTY						
MUNICIPAL	3,111	3,300	3,477	3,578	3,676	3,741
MANUFACTURING	1,043	1,106	1,154	1,200	1,238	1,315
MINING	122	125	127	128	129	130
LIVESTOCK	756	756	756	756	756	756
IRRIGATION	71,800	68,963	66,238	63,621	61,107	58,692
ZAVALA COUNTY TOTAL	76,832	74,250	71,752	69,283	66,906	64,634

Table D-3. Water Management Strategies from the 2012 State Water Plan Involving Groundwater in the Counties of Groundwater Management Area 13
(all values in acre-feet per year)

Local Groundwater Carrizo-Wilcox Aquifer (Includes Overdrafts)

County	Aquifer	2010	2020	2030	2040	2050	2060
Atascosa	Carrizo-Wilcox	1,210	2,017	2,824	2,824	2,824	5,242
Bexar	Carrizo-Wilcox	4,150	6,568	8,180	8,180	12,210	16,249
Caldwell	Carrizo-Wilcox	403	1,209	2,016	2,419	2,983	4,356
Guadalupe	Carrizo-Wilcox	0	0	605	1,210	2,016	2,823
Karnes	Carrizo-Wilcox	323	323	323	323	323	323
Wilson	Carrizo-Wilcox	807	1,613	1,613	2,420	3,710	5,001
Total Project		6,893	11,730	15,561	17,376	24,066	33,994

Brackish Groundwater Desalination (Wilcox Aquifer)

County	Aquifer	2010	2020	2030	2040	2050	2060
Bexar	Carrizo-Wilcox	0	12,000	21,000	26,400	26,400	26,400
Guadalupe	Carrizo-Wilcox	0	0	3,680	3,680	5,358	5,358
Wilson	Carrizo-Wilcox	0	0	7,516	8,636	18,158	19,658
Total Project		0	12,000	32,196	38,716	49,916	51,416

Development of Carrizo-Wilcox Aquifer (Region K)

County	Aquifer	2010	2020	2030	2040	2050	2060
Caldwell	Carrizo-Wilcox	0	1,687	1,687	1,687	1,687	1,687
Total Project		0	1,687	1,687	1,687	1,687	1,687

Hays/Caldwell PUA Project (Incl. Gonzales Co.)

County	Aquifer	2010	2020	2030	2040	2050	2060
Caldwell	Carrizo-Wilcox	0	6,520	17,931	15,754	16,396	17,912
Gonzales	Carrizo-Wilcox	0	2,139	4,187	9,008	15,458	22,904
Total Project		0	8,659	22,118	24,762	31,854	40,816

CRWA Wells Ranch Project Phase I

County	Aquifer	2010	2020	2030	2040	2050	2060
Gonzales	Carrizo-Wilcox	10,400	10,400	10,400	10,400	10,400	10,400
Total Project		10,400	10,400	10,400	10,400	10,400	10,400

Regional Carrizo for SAWS

County	Aquifer	2010	2020	2030	2040	2050	2060
Gonzales	Carrizo-Wilcox	0	11,687	11,687	11,687	11,687	11,687
Total Project		0	11,687	11,687	11,687	11,687	11,687

Table D-3. Water Management Strategies from the 2012 State Water Plan Involving Groundwater in the Counties of Groundwater Management Area 13
(all values in acre-feet per year)

Regional Carrizo for SSLGC Project Expansion (incl. Gonzales County)

County	Aquifer	2010	2020	2030	2040	2050	2060
Gonzales	Carrizo-Wilcox	0	7,455	9,141	10,921	12,603	13,678
Guadalupe	Carrizo-Wilcox	0	3,525	3,525	3,525	3,525	4,259
Total Project		0	10,980	12,666	14,446	16,128	17,937

TWA Regional Carrizo (incl. Gonzales Co.)

County	Aquifer	2010	2020	2030	2040	2050	2060
Gonzales	Carrizo-Wilcox	0	33,828	40,717	44,591	48,556	52,575
Total Project		0	33,828	40,717	44,591	48,556	52,575

Brackish Water Desalination

County	Aquifer	2010	2020	2030	2040	2050	2060
Maverick	Carrizo-Wilcox	0	260	260	260	272	641
Webb	Yegua-Jackson	0	1,523	1,523	1,523	1,523	1,523
Webb	Yegua-Jackson	1,120	2,500	2,500	2,500	2,500	2,500
Total Project		1,120	4,283	4,283	4,283	4,295	4,664

**Table D-4. Total Groundwater Pumping from Groundwater-Based Water Management Strategies in Counties within Groundwater Management Area 13
By County and Aquifer**

County	Aquifer	2010	2020	2030	2040	2050	2060
Atascosa	Carrizo-Wilcox	1,210	2,017	2,824	2,824	2,824	5,242
Bexar	Carrizo-Wilcox	4,150	18,568	29,180	34,580	38,610	42,649
Caldwell	Carrizo-Wilcox	403	9,416	21,634	19,860	21,066	23,955
Dimmit	N/A	0	0	0	0	0	0
Frio	N/A	0	0	0	0	0	0
Gonzales	Carrizo-Wilcox	10,400	65,509	76,132	86,607	98,704	111,244
Guadalupe	Carrizo-Wilcox	0	3,525	7,810	8,415	10,899	12,440
Karnes	Carrizo-Wilcox	323	323	323	323	323	323
La Salle	N/A	0	0	0	0	0	0
Maverick	Carrizo-Wilcox	0	260	260	260	272	641
McMullen	N/A	0	0	0	0	0	0
Medina	N/A	0	0	0	0	0	0
Uvalde	N/A	0	0	0	0	0	0
Webb	Yegua-Jackson	1,120	4,023	4,023	4,023	4,023	4,023
Wilson	Carrizo-Wilcox	807	1,613	9,129	11,056	21,868	24,659
Zapata	N/A	0	0	0	0	0	0
Zavala	N/A	0	0	0	0	0	0

**Table D-5. Projections for Oil and Gas Water Use in Counties in Groundwater Management Area 13
Data from Nicot and others (2012)
(all values in acre-feet per year)**

County	2011	2015	2020	2025	2030	2035	2040	2045	2050	2055	2060
Atascosa	1,012	2,993	2,770	2,713	2,706	2,700	2,693	2,393	2,021	1,649	1,279
Bexar	0	0	0	0	0	0	0	0	0	0	0
Caldwell	75	98	123	111	98	85	72	59	46	33	20
Dimmit	3,708	4,874	4,919	5,001	5,001	4,952	4,337	3,580	2,824	2,068	1,315
Frio	729	1,167	1,217	1,243	1,250	1,215	1,178	1,142	986	804	620
Gonzales	2,164	1,791	1,600	1,405	1,207	1,010	813	616	418	221	24
Guadalupe	0	10	10	10	10	10	10	10	10	10	10
Karnes	3,882	2,820	2,528	2,229	1,919	1,603	1,288	975	662	349	35
LaSalle	2,889	4,569	4,617	4,705	4,772	4,830	4,263	3,541	2,819	2,098	1,380
Maverick	174	1,652	1,988	2,364	2,737	3,111	2,933	2,617	2,302	1,986	1,674
McMullen	1,720	2,653	2,912	3,203	3,448	3,666	3,398	3,010	2,622	2,235	1,850
Medina	0	0	0	0	0	0	0	0	0	0	0
Uvalde	0	0	0	0	0	0	0	0	0	0	0
Webb	4,599	3,878	3,708	3,257	2,804	2,397	2,007	1,623	1,238	796	341
Wilson	418	1,671	1,929	1,740	1,548	1,357	1,165	973	782	590	399
Zapata	30	78	85	93	89	76	66	57	49	40	31
Zavala	407	2,140	2,531	2,379	2,257	2,118	1,977	1,838	1,559	1,245	932
Total	21,807	30,394	30,937	30,453	29,846	29,130	26,200	22,434	18,338	14,124	9,910

**Table D-6. Submitted Updates to Future Pumping by SAWS
Submitted on June 27, 2013 via email by Steven Siebert**

Location	Volume in acre-feet per year
South Bexar County	
Brackish Groundwater Desalination Program	33,600
Local Carrizo	28,000
Total	61,600
Gonzales County	
Regional Carrizo Project Permitted	11,688
Gonzales Water Supply Corporation	1,000
Total	12,688

Table D-7. Gonzales UWCD Pumping Projections
Page 1 of 3

Carrizo Aquifer Projected Usage

	2010 MAG	2014 MAG	2017 MAG	2020 MAG	2030 MAG	2040 MAG	2050 MAG	2060 MAG	
	45,844	45,844	45,844	55,717	63,718	69,192	69,371	69,371	
Company	2010 Usage (ac-ft)	2014 Usage (ac-ft)	2017 Usage (ac-ft)	2020 Usage (ac-ft)	2030 Usage (ac-ft)	2040 Usage (ac-ft)	2050 Usage (ac-ft)	2060 Usage (ac-ft)	2070 Usage (ac-ft)
SSLGC	10,433	18,394	18,394	18,394	18,394	18,394	18,394	18,394	18,394
CRWA	1,850	1,850	1,850	2,850	2,850	2,850	2,850	2,850	2,850
AQUA	1,758	1,758	1,758	4,750	4,750	4,750	4,750	4,750	4,750
GCWSC	1,687	1,687	1,687	4,967	4,967	4,967	4,967	4,967	4,967
SAWS		11,103	11,103	11,103	11,103	11,103	11,103	11,103	11,103
District Other	7,400	7,400	7,900	8,400	8,900	9,400	9,900	10,400	10,900
HCPUA		0	1,900	6,270	9,785	9,785	9,785	9,785	9,785
TWA		0	4,750	9,500	14,250	14,250	14,250	14,250	14,250
CRWA		0	2,000	4,180	4,180	4,180	4,180	4,180	4,180
	23,128	42,192	51,342	70,414	79,179	79,679	80,179	80,679	81,179

Table D-7. Gonzales UWCD Pumping Projections
Page 2 of 3

Wilcox Aquifer Projected Usage

	2010 MAG	2020 MAG	2030 MAG	2040 MAG	2050 MAG	2060 MAG	
	32,061	32,061	32,061	32,061	32,061	32,061	
	2010 Usage (ac-ft)	2020 Usage (ac-ft)	2030 Usage (ac-ft)	2040 Usage (ac-ft)	2050 Usage (ac-ft)	2060 Usage (ac-ft)	2070 Usage (ac-ft)
Irrigation	246	250	250	250	250	250	250
Agri/Commercial	0	50	50	50	50	50	50
Public Supply	0	50	50	50	50	50	50
Exempt	104	87	73	64	62	61	61
Frack Water	0	0	0	0	0	0	0
	350	437	423	414	412	411	411

Queen City Aquifer Projected Usage

	2010 MAG	2020 MAG	2030 MAG	2040 MAG	2050 MAG	2060 MAG	
	5,349	5,349	5,349	5,349	5,349	5,349	
	2010 Usage (ac-ft)	2020 Usage (ac-ft)	2030 Usage (ac-ft)	2040 Usage (ac-ft)	2050 Usage (ac-ft)	2060 Usage (ac-ft)	2070 Usage (ac-ft)
Irrigation	191	191	191	191	191	191	191
Agri/Commercial	390	400	400	400	400	400	400
Public Supply	419	500	500	500	500	500	500
Exempt	1,207	1,005	850	738	704	714	714
Frack Water	84	120	120	100	0	0	0
	2,291	2,216	2,061	1,929	1,795	1,805	1,805

Table D-7. Gonzales UWCD Pumping Projections
Page 3 of 3

Sparta Aquifer Projected Usage

	2010 MAG	2020 MAG	2030 MAG	2040 MAG	2050 MAG	2060 MAG	
	3,552	3,552	3,552	3,552	3,552	3,552	
	2010 Usage (ac-ft)	2020 Usage (ac-ft)	2030 Usage (ac-ft)	2040 Usage (ac-ft)	2050 Usage (ac-ft)	2060 Usage (ac-ft)	2070 Usage (ac-ft)
Irrigation	55	55	55	55	55	55	55
Agri/Commercial	22	22	22	22	22	22	22
Public Supply	0	0	0	0	0	0	0
Exempt	165	137	116	100	96	97	97
Frack Water	165	200	200	100	0	0	0
	407	414	393	277	173	174	174

Yegua Jackson Aquifer Projected Usage

	2010 MAG	2020 MAG	2030 MAG	2040 MAG	2050 MAG	2060 MAG	
	865	865	865	865	865	865	
	2010 Usage (ac-ft)	2020 Usage (ac-ft)	2030 Usage (ac-ft)	2040 Usage (ac-ft)	2050 Usage (ac-ft)	2060 Usage (ac-ft)	2070 Usage (ac-ft)
Irrigation	0	0	0	0	0	0	0
Agri/Commercial	0	0	0	0	0	0	0
Public Supply	0	0	0	0	0	0	0
Exempt	99	89	69	60	58	58	58
Frack Water	2,112	2200	2200	1000	0	0	0
	2,211	2,289	2,269	1,060	58	58	58

Table D-9. Plum Creek Conservation District Permitted Wells' Water Use

Permittee	Latitude	Longitude	State Well No	PUMPING AMOUNTS BY YEAR						
				2005	2006	2007	2008	2009	2010	2011
Twidwell	29.6975	-97.51919						21.000	0.800	2.000
Aqua Water Supply #1	29.846389	-97.530556	6712312				19.440	15.740	14.810	12.645
Aqua Water Supply #2	29.845833	97.531111	6712311				37.745	20.920	20.430	17.923
Aqua Water Supply #3	29.8475	97.529722	6712313				54.940	81.270	77.150	75.184
Total Aqua(#1,#2,#3)					90.230	105.040				
City of Lockhart 3B	29.829722	-97.562778	6712501		81.160	130.000	63.840	154.940	102.400	154.900
City of Lockhart 4A	29.8225	-97.562222	6712523		7.430	84.000	31.290	80.740	28.600	142.100
City of Lockhart 5A	29.8175	-97.5675	6712524		14.520	14.000	11.980	55.440	49.700	86.920
City of Lockhart 9	29.815556	-97.545833	6712528		97.250	103.000	91.370	162.890	130.000	311.810
City of Lockhart 10	29.811667	-97.555833	6712527		63.840	35.000	33.340	133.690	6.100	8.840
City of Lockhart 11	29.820278	-97.552778	6712529		35.200	97.000	20.650	36.810	91.300	79.060
City of Lockhart 12	29.825278	-97.548333	6712113		86.400	93.000	62.190	123.600	81.900	236.740
City of Luling #1	29.681389	-97.640278	6719601				0.000	0.000	0.000	0.000
City of Luling #5	29.683333	-97.639167	6719605				0.000	0.000	0.000	0.000
City of Luling #8	29.690278	-97.651944	6719628				0.000	0.000	0.000	0.000
City of Luling #10	29.690278	-97.648333					0.000	0.000	0.000	0.000
Polonia #2	29.919413	-97.563028	6704512	125.250	147.850	120.800	170.730	165.400	167.830	193.090
Polonia #3	29.907079	-97.549735	6704803	110.980	98.970	93.210	64.310	44.980	90.130	81.120
Polonia #4	29.907684	-97.547747	6704804	115.280	120.060	110.480	194.710	251.840	109.660	126.930
Polonia Brownsboro #1	29.817221	-97.635943	6711623	141.840	219.860	224.710	283.570	253.340	250.460	293.930
Polonia Brownsboro #2	29.818595	-97.635535		72.910	13.940	0.000	0.000	3.280	0.000	0.000
Dale Water	29.906528	-97.570547		95.690	111.800	109.140	139.780	44.890	35.240	44.530
Smith #1	29.826889	-97.6423					69.418	78.072	2.172	60.656
Smith #2	29.831111	-97.645361					45.563	21.657	13.033	35.562
Horton	29.891944	-97.509167					43.058	16.307	0.000	14.397
Wells JKW	29.838333	-97.544444					27.141	0.590	4.860	15.860
Giacomel	29.820111	-97.614278					7.950	6.040	1.660	6.040
Pratka #1	29.755694	-97.566722					6.430	6.880	6.020	19.960
Pratka #2	29.776983	-97.557783					0.000	0.000	0.000	0.000
Pratka #3	29.755167	-97.565483					0.000	0.000	0.000	0.000
Polonia Hinds #1	29.77134915	-97.55360843					0.000	0.000	0.000	0.000
Hazelett #1	29.863533	-97.629533					0.000	44.000	0.000	53.690
Hazelett #2	29.78935	-97.571767					0.000	0.000	0.000	0.000
Rodriguez	29.874983	-97.58785							0.030	5.260
Lester #2	29.715817	-97.527933								4.560
Lester #1	29.714933	-97.528467								4.560
Lester #3	29.716633	-97.527517								4.560
Cal-Maine Brown #1	29.750449	-97.519472								0.000
Cal-Maine Brown #6	29.7456	-97.521833								0.000
Cal-Maine Smith #1	29.754083	-97.52615								0.030
Cal-Maine Smith #2	29.75965	-97.52765								46.920
Cal-Maine #2	29.760483	-97.529583								53.420
Cal-Maine #3	29.759067	-97.530083								53.350
Cal-Maine #4	29.7572	-97.53005								35.280
Cal-Maine #5	29.756233	-97.5296								31.340
Cal-Maine Monitor	29.756233	-97.5296								0.000
Sommerlatte #1	29.680556	-97.679722								0.000
Sommerlatte #2	29.691667	-97.611389								48.270
Sommerlatte #3	29.69	-97.6175								2.350
Sommerlatte #4	29.68	-97.619722								0.000
McCrary	29.79135	-97.64435								0.000
Clements	29.8875	-97.515								0.000

691.950 1188.510 1319.380 1479.445 1624.316 1284.285 2363.767

**Table D-10. EOG Resources
Rig Supply/Frac Well Water Usage for McMullen GCD
2012**

Well Id	Jan.	Feb.	Mar.	Apr.	May	June	July	Aug.	Sept.	Oct.	Nov.	Dec.
Hamilton WSW	0	0	0	0	0	0	0	89,667	0	0	0	318,929
Henry WSW	0	0	0	0	33,500	0	0	0	0	0	0	0
Hollan-Haynes WSW	313,143	645,143	278,643	82,381	166,024	0	0	357,762	224,905	31,024	603,190	119,048
Lowe Pasture WSW	0	0	0	0	0	164,500	0	0	153,595	271,262	0	0
Naylor Jones 43 WSW	0	404,357	522,524	0	58,405	0	0	0	261,000	0	0	0
River Lowe WSW	0	0	0	0	63,500	0	0	0	0	0	0	0
TOTAL	313,143	1,049,500	801,167	82,381	321,429	164,500	0	447,429	639,500	302,286	603,190	437,977

Water usage reported in barrels



**Guadalupe County Groundwater
Conservation District**

**P.O. Box 1221
Seguin, TX 78156-1221
830-379-5969
gcgcd@sbcglobal.net
www.gcgcd.org**

April 26, 2013

William R. Hutchison, Ph.D, P.E.,P.G.
9802 Murmuring Creek Drive
Austin, TX 78736

billhutch@texasgw.com

As we discussed yesterday about the location of well fields in Guadalupe County and permitted production by aquifer is listed below.

Springs Hill WSC, 3 wells (500 gpm ea) in the Carrizo Aquifer permitted for 1,000 af/yr
Well #1 Lat 29.444166; Long 97.840277 Well #2 1,500 feet east of #1; Well #3 1,500 east of #2

Canyon Regional Water Authority permitted 3 well (450 gpm ea), total production permit 2,603 af/yr
Well #1 Lat 29.454950, Long 97.78392
Well #2 Lat 29.45623, Long 97.79583
Well #3 Lat 29.450035, Long 97.79819
Wilcox production permits 3,026 af/yr, no wells drilled or location of wells

Schertz/Seguin Local Government Corp. 5 wells, total production permit 3,226 af/yr, Carrizo Aquifer
Have 3 drilling permits, to date no wells drilled or in production
Well #1 Lat 29. 23127N, Long 97.51150N
Well #2 lat 29.224299N, Long 97.511502W
Well #3 Lat 29.224313N, Long 97.515191W

Crystal Clear WSC requesting drilling and production permits in the Wilcox Aquifer for three wells (well # 1&2 167 gpm ea, #3 125 gpm) production permits for 741.6 af/yr Hearing on May 9, 2013 will be issued 30 days after hearing
Well #1 Lat 29.391574 N, Long 97.434932W
Well #2 Lat 29.39042N, Long 97.44055W
Well #3 Lat 29.385464, Long 97.441648W

If any additional information is needed please contact me.

Sincerely,

Ronald A Naumann
President

Bill Hutchison

From: Ed Walker <wgcd.swtrea@sbcglobal.net>
Sent: Friday, February 08, 2013 1:40 PM
To: Bill Hutchison; Mike Mahoney
Subject: Pumpage numbers for GMA 2011 and 2012

Bill/Mike,

All I have is Cameron Turner's 2011 irrigation estimates which look ok to me and should suffice for 2012. Beyond that all that we have is the TWDB numbers supplied to us for our management plan which was from the 2007 State Water Plan, and approved 2/12 by the board. They are as follows;

Dimmit County 5,569AF for Irr 9,158AF for Other Ttl 14,727AF

LaSalle County 8,023AF for Irr 254AF for Other Ttl 8,277AF

Zavala County 55,643AF for Irr 21,189AF for Other Ttl 76,832AF

Note: Dimmit County "Other Use" includes 1000AF for mining = OK
LaSalle County "Other Use" only has 254AF for mining and therefore should add
an additional 1850-2000AF
Zavala County "Other Use" has 122AF for mining which is low by 500AF

If one adds the additional mining use, the total increases from 99,836AF to approximately 102,000Af
ED

GAM RUN 10-012 MAG: MODELED AVAILABLE GROUNDWATER FOR THE CARRIZO-WILCOX, QUEEN CITY, AND SPARTA AQUIFERS IN GROUNDWATER MANAGEMENT AREA 13

by Shirley C. Wade, Ph.D., P.G.
Texas Water Development Board
Groundwater Resources Division
Groundwater Availability Modeling Section
(512) 936-0883
August 2, 2012

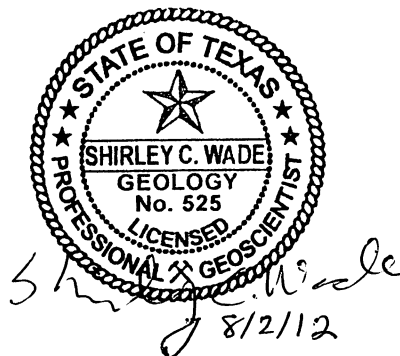

The seal appearing on this document was authorized by Shirley C. Wade, P.G. 525, on August 2, 2012.

This page is intentionally left blank

GAM RUN 10-012 MAG: MODELED AVAILABLE GROUNDWATER FOR THE CARRIZO-WILCOX, QUEEN CITY, AND SPARTA AQUIFERS IN GROUNDWATER MANAGEMENT AREA 13

by Shirley C. Wade, Ph.D., P.G.
Texas Water Development Board
Groundwater Resources Division
Groundwater Availability Modeling Section
(512) 936-0883
August 2, 2012

EXECUTIVE SUMMARY:

The modeled available groundwater for Groundwater Management Area 13 for the Carrizo-Wilcox, Queen City, and Sparta aquifers is summarized in Table 1, 2, and 3 for use in the regional water planning process. These values are also listed by decade for each aquifer by county (Table 4), river basin (Table 5), regional water planning group (Table 6), and groundwater conservation district (Table 7). The modeled available groundwater estimates for the Queen City, Sparta, and Carrizo-Wilcox aquifers range from approximately 399,000 acre-feet per year in 2010 to 425,000 acre-feet per year in 2060 (Table 4). The estimates were extracted from results of Groundwater Availability Model Run 09-034, scenario 4, which meets the desired future conditions adopted by members of Groundwater Management Area 13.

This report reflects the official release of the revised groundwater district boundaries by the Texas Commission on Environmental Quality (TCEQ). Specifically, this report reflects the division of modeled available groundwater between the Gonzales County Underground Water Conservation District and Plum Creek Conservation District based on the new groundwater conservation district boundaries.

REQUESTOR:

Mr. Mike Mahoney from the Evergreen Underground Water Conservation District acting on behalf of Groundwater Management Area 13.

DESCRIPTION OF REQUEST:

In a letter dated April 13, 2010 and received by the Texas Water Development Board (TWDB) on April 15, 2010, Mr. Mike Mahoney provided the TWDB with the desired future conditions of the Carrizo-Wilcox, Queen City, and Sparta aquifers adopted by the groundwater conservation districts in Groundwater Management Area 13. The desired future conditions for the Carrizo-Wilcox, Queen City, and Sparta aquifers, as described in Resolution R 2010-01 and adopted April 9, 2010 by the groundwater conservation districts within Groundwater Management Area 13, are described below:

- “In reference to GAM Run 09-034, the committee has considered, the base scenario of an average drawdown of 22 feet, scenario 2 an average drawdown of 22 feet, scenario 3 an average drawdown of 23 feet and scenario 4 an average drawdown of 23 feet;”
- “The district members of Groundwater Management Area 13, adopt scenario 4, and an average drawdown of 23 feet for the Sparta, Weches, Queen City, Reklaw, Carrizo, and the Wilcox Aquifers”

In response to receiving the adopted desired future conditions, TWDB has estimated the modeled available groundwater for the Carrizo-Wilcox, Queen City, and Sparta Aquifers in Groundwater Management Area 13.

METHODS:

Groundwater Management Area 13, located in south central Texas, includes the southern part of the Queen City, Sparta, and Carrizo-Wilcox aquifers (Figure 1). For the previously completed Groundwater Availability Model Run 09-034 (Wade and Jigmond, 2010) average recharge and evapotranspiration rates and initial streamflows based on the historical calibration-verification runs, representing 1981 to 1999 were summarized. These averages were then used for each year of the 61-year predictive simulations along with pumping specified by Groundwater Management Area 13 members in four scenarios. The results of the pumping scenarios were reviewed by members of Groundwater Management Area 13 to develop their desired future conditions. Model scenario 4 resulted in an overall average drawdown of 23 feet for the Queen City, Sparta, and Carrizo-Wilcox aquifers and for the Weches and Reklaw confining units. The pumping for scenario 4 was extracted from the model results and divided by county, river basin, regional water planning area and groundwater conservation district within Groundwater Management Area 13 (Figure 2).

Modeled Available Groundwater and Permitting

As defined in Chapter 36 of the Texas Water Code, “modeled available groundwater” is the estimated average amount of water that may be produced annually to achieve a desired future condition. Groundwater conservation districts are required to consider modeled available groundwater, along with several other factors, when issuing permits in order to manage groundwater production to achieve the desired future condition(s). The other factors districts must consider include annual precipitation and production patterns, the estimated amount of pumping exempt from permitting, existing permits, and a reasonable estimate of actual groundwater production under existing permits. The estimated amount of pumping exempt from permitting, which the Texas Water Development Board is required to develop after soliciting input from applicable groundwater conservation districts, will be provided in a separate report.

PARAMETERS AND ASSUMPTIONS:

The parameters and assumptions for the groundwater availability model for the southern part of the Queen City, Sparta, and Carrizo-Wilcox aquifers are described below:

- Version 2.01 of the groundwater availability model for the southern part of the Queen City, Sparta, and Carrizo-Wilcox aquifers was used for this analysis
- See Deeds and others (2003) and Kelley and others (2004) for assumptions and limitations of the groundwater availability model for the southern part of the Queen City, Sparta, and Carrizo-Wilcox aquifers.
- The model includes eight layers representing:
 - the Sparta Aquifer (layer 1),
 - the Weches Formation (layer 2),
 - the Queen City Aquifer (layer 3),
 - the Reklaw Formation (layer 4),
 - the Carrizo Aquifer (layer 5),
 - the upper and where the upper is missing, the middle Wilcox Aquifer (layer 6),
 - the middle Wilcox Aquifer (layer 7), and
 - the lower Wilcox Aquifer (layer 8).

- Groundwater in the groundwater availability model for the southern portion of the Queen City, Sparta, and Carrizo-Wilcox aquifers ranges from fresh to saline (Kelley and others, 2004).
- The root mean square error (a measure of the difference between simulated and measured water levels during model calibration) in the entire model for 1999 is 23 feet for the Sparta Aquifer, 18 feet for the Queen City aquifer, and 33 feet for the Carrizo aquifer (Kelley and others, 2004).
- Recharge rates, evapotranspiration rates, and initial streamflows are averages of historic estimates from 1981 to 1999.

RESULTS:

The modeled available groundwater for the Carrizo-Wilcox Aquifer that achieves the desired future conditions adopted by Groundwater Management Area 13 increases from 375,654 to 404,000 acre-feet per year between 2010 and 2060 (Table 1). The modeled available groundwater for the Queen City Aquifer in Groundwater Management Area 13 declines from 16,311 to 14,538 acre-feet per year over the same time period (Table 2). The modeled available groundwater for the Sparta Aquifer in Groundwater Management Area 13 declines from 6,800 to 6,365 acre-feet per year (Table 3). The modeled available groundwater in tables 1, 2, and 3 has been summarized by county, river basin, and regional water planning area for use in the regional water planning process.

The modeled available groundwater is also summarized by county (Table 4), river basin (Table 5), regional water planning area (Table 6), and groundwater conservation district (Table 7). In Table 7, the modeled available groundwater among all districts has been calculated both excluding and including areas outside the jurisdiction of a groundwater conservation district.

LIMITATIONS:

The groundwater model used in completing this analysis is the best available scientific tool that can be used to meet the stated objective(s). To the extent that this analysis will be used for planning purposes and/or regulatory purposes related to pumping in the past and into the future, it is important to recognize the assumptions and limitations associated with the use of the results. In reviewing the use of models in environmental regulatory decision making, the National Research Council (2007) noted:

“Models will always be constrained by computational limitations, assumptions, and knowledge gaps. They can best be viewed as tools to help inform decisions rather than as machines to generate truth or make decisions. Scientific advances will never make it possible to build a perfect model that accounts for every aspect of reality or to prove that a given model is correct in all respects for a particular regulatory application. These characteristics make evaluation of a regulatory model more complex than solely a comparison of measurement data with model results.”

A key aspect of using the groundwater model to evaluate historic groundwater flow conditions includes the assumptions about the location in the aquifer where historic pumping was placed. Understanding the amount and location of historic pumping is as important as evaluating the volume of groundwater flow into and out of the district, between aquifers within the district (as applicable), interactions with surface water (as applicable), recharge to the aquifer system (as applicable), and other metrics that describe the impacts of that pumping. In addition, assumptions regarding precipitation, recharge, and streamflow are specific to a particular historic time period.

Because the application of the groundwater model was designed to address regional scale questions, the results are most effective on a regional scale. The TWDB makes no warranties or representations relating to the actual conditions of any aquifer at a particular location or at a particular time.

It is important for groundwater conservation districts to monitor groundwater pumping and overall conditions of the aquifer. Because of the limitations of the groundwater model and the assumptions in this analysis, it is important that the groundwater conservation districts work with the TWDB to refine this analysis in the future given the reality of how the aquifer responds to the actual amount and location of pumping now and in the future. Historic precipitation patterns also need to be placed in context as future climatic conditions, such as dry and wet year precipitation patterns, may differ and affect groundwater flow conditions.

REFERENCES:

- Deeds, N., Kelley, V., Fryar, D., Jones, T., Whallon, A. J., and Dean, K. E., 2003, Groundwater Availability Model for the Southern Carrizo-Wilcox Aquifer: contract report to the Texas Water Development Board, 452 p.
- Donnelly, A.C.A., 2007a, GAM Run 06-29, Texas Water Development Board GAM Run Report, 59 p.
- Donnelly, A.C.A., 2007b, GAM Run 07-16, Texas Water Development Board GAM Run Report, 63 p.
- Donnelly, A.C.A., 2007c, GAM Run 07-17, Texas Water Development Board GAM Run Report, 38 p.
- Kelley, V. A., Deeds, N. E., Fryar, D. G., and Nicot, J. P., 2004, Groundwater availability models for the Queen City and Sparta aquifers: contract report to the Texas Water Development Board, 867 p.
- National Research Council, 2007, Models in Environmental Regulatory Decision Making. Committee on Models in the Regulatory Decision Process, National Academies Press, Washington D.C., 287 p.
- Wade S.C., 2008a, GAM Run 08-41, Texas Water Development Board GAM Run Report, 56 p.
- Wade S.C., 2008b, GAM Run 08-42, Texas Water Development Board GAM Run Report, 56 p.
- Wade S.C., 2008c, GAM Run 08-43, Texas Water Development Board GAM Run Report, 58 p.
- Wade S.C. and Jigmond, M., 2010, GAM Run 09-034, Texas Water Development Board GAM Run Report, 146 p.

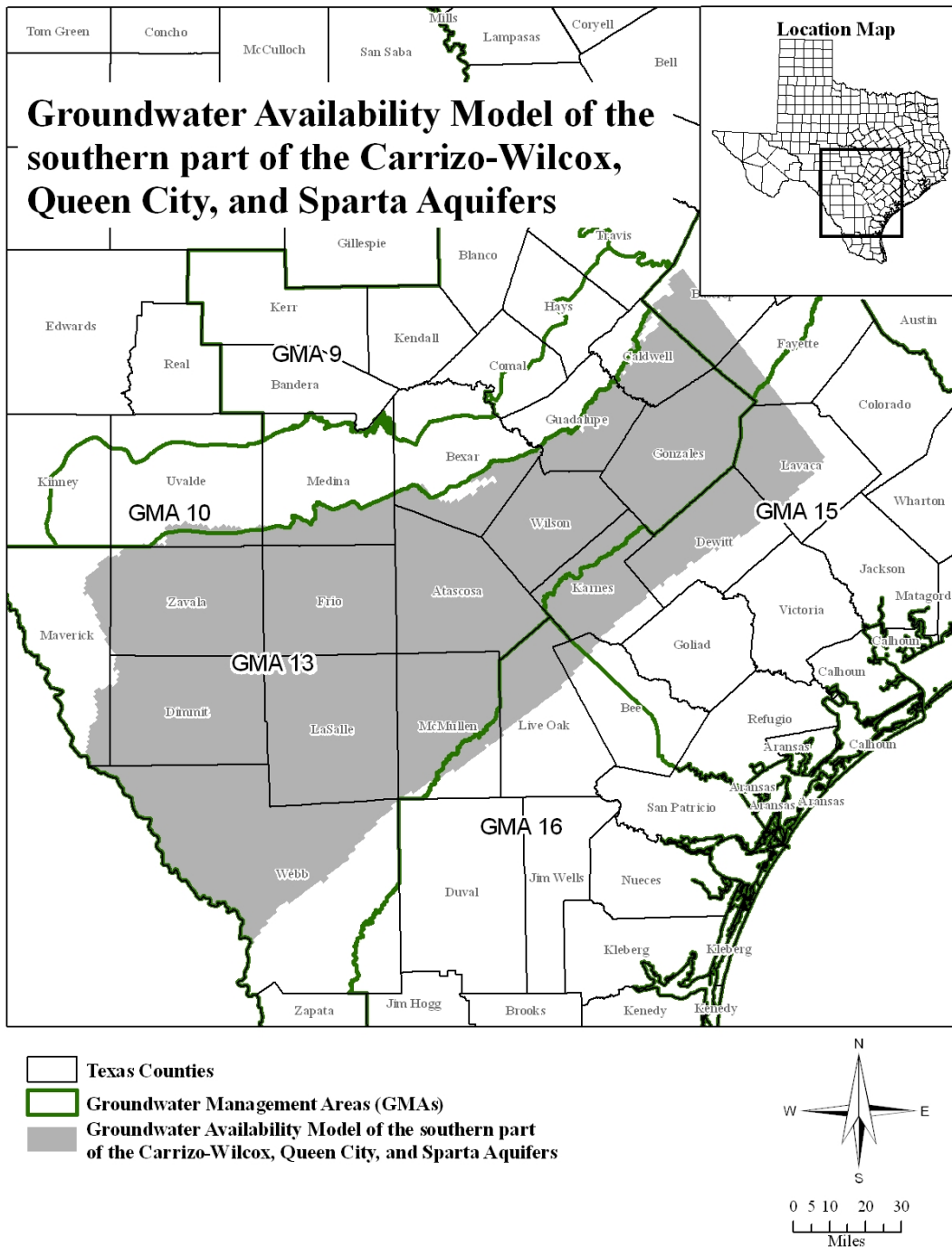

FIGURE 1. MAP SHOWING THE AREAS COVERED BY THE GROUNDWATER AVAILABILITY MODEL FOR THE SOUTHERN PART OF THE CARRIZO-WILCOX, QUEEN CITY, AND SPARTA AQUIFERS.

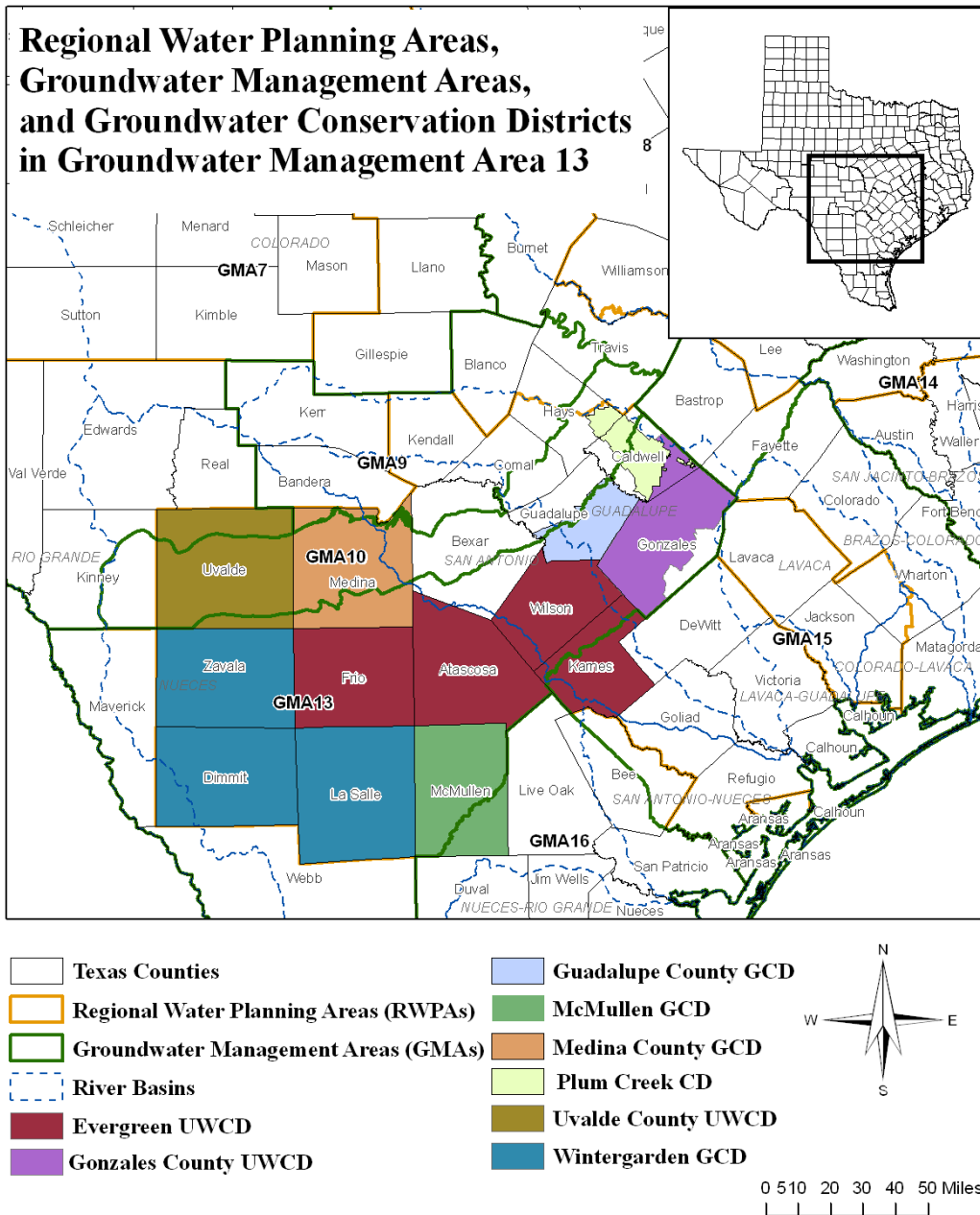

FIGURE 2. MAP SHOWING REGIONAL WATER PLANNING AREAS, GROUNDWATER MANAGEMENT AREAS, GROUNDWATER CONSERVATION DISTRICTS (GCDs), COUNTIES, AND RIVER BASINS IN AND NEIGHBORING GROUNDWATER MANAGEMENT AREA 13. UWCD REFERS TO UNDERGROUND WATER CONSERVATION DISTRICT.

TABLE 1. MODELED AVAILABLE GROUNDWATER BY DECADE FOR THE CARRIZO-WILCOX AQUIFER IN GROUNDWATER MANAGEMENT AREA 13. RESULTS ARE IN ACRE-FEET PER YEAR AND ARE DIVIDED BY COUNTY, RIVER BASIN, AND REGIONAL WATER PLANNING AREA.

County	Regional Water Planning Area	Basin	Year					
			2010	2020	2030	2040	2050	2060
Atascosa	L	Nueces	67,829	68,656	70,249	71,827	73,666	75,688
		San Antonio	120	120	120	120	120	120
Bexar	L	Nueces	14,198	14,198	14,198	14,198	14,198	14,198
		San Antonio	12,080	12,080	12,080	12,080	12,080	11,909
Caldwell	L	Colorado	593	593	593	593	593	593
		Guadalupe	43,951	43,951	43,543	43,543	42,967	42,967
Dimmit	L	Nueces	3,253	3,253	3,253	3,253	3,253	3,253
		Rio Grande	106	106	106	106	106	106
Frio	L	Nueces	81,551	79,089	76,734	74,439	72,222	70,030
Gonzales	L	Guadalupe	52,268	62,101	70,102	75,576	75,755	75,755
		Lavaca	215	215	215	215	215	215
Guadalupe	L	Guadalupe	8,868	9,460	9,910	11,648	12,168	12,668
		San Antonio	1,373	1,373	1,373	1,373	1,373	1,373
Karnes	L	Guadalupe	185	195	207	215	220	224
		Nueces	87	92	97	101	103	105
		San Antonio	787	830	878	915	936	951
La Salle	L	Nueces	6,454	6,454	6,454	6,454	6,454	6,454
Maverick	M	Nueces	777	777	777	472	472	472
		Rio Grande	1,266	1,266	1,247	1,205	1,098	1,060
McMullen	N	Nueces	1,819	1,819	1,819	1,819	1,819	1,819
Medina	L	Nueces	2,542	2,519	2,507	2,507	2,507	2,507
		San Antonio	26	26	26	26	26	26
Uvalde	L	Nueces	2,971	1,230	828	828	828	828
Webb	M	Nueces	92	92	92	92	92	92
		Rio Grande	824	824	824	824	824	824
Wilson	L	Guadalupe	624	672	731	791	861	938
		Nueces	7,151	7,311	7,505	7,703	7,932	8,185
		San Antonio	27,785	29,003	30,481	31,992	33,738	35,671
Zavala	L	Nueces	35,859	35,859	35,521	35,388	35,288	34,969
Total			375,654	384,164	392,470	400,303	401,914	404,000

TABLE 2. MODELED AVAILABLE GROUNDWATER BY DECADE FOR THE QUEEN CITY AQUIFER IN GROUNDWATER MANAGEMENT AREA 13. RESULTS ARE IN ACRE-FEET PER YEAR AND ARE DIVIDED BY COUNTY, RIVER BASIN, AND REGIONAL WATER PLANNING AREA.

County	Regional Water Planning Area	Basin	Year					
			2010	2020	2030	2040	2050	2060
Atascosa	L	Nueces	4,546	4,546	4,513	4,405	4,300	4,202
Caldwell	L	Guadalupe	306	306	306	306	306	306
Dimmit	L	Nueces	0	0	0	0	0	0
		Rio Grande	0	0	0	0	0	0
Frio	L	Nueces	4,748	4,582	4,422	4,270	4,124	3,983
Gonzales	L	Guadalupe	5,030	5,030	5,030	5,030	5,030	5,030
		Lavaca	35	35	35	35	35	35
Guadalupe	L	Guadalupe	0	0	0	0	0	0
Karnes	L	Guadalupe	0	0	0	0	0	0
		Nueces	0	0	0	0	0	0
		San Antonio	0	0	0	0	0	0
La Salle	L	Nueces	1	1	1	1	1	1
McMullen	N	Nueces	136	136	136	136	136	136
Webb	M	Nueces	0	0	0	0	0	0
		Rio Grande	0	0	0	0	0	0
Wilson	L	Guadalupe	128	114	101	90	80	72
		Nueces	148	132	117	104	93	83
		San Antonio	1,233	1,094	973	866	772	690
Zavala	L	Nueces	0	0	0	0	0	0
Total			16,311	15,976	15,634	15,243	14,877	14,538

TABLE 3. MODELED AVAILABLE GROUNDWATER BY DECADE FOR THE SPARTA AQUIFER IN GROUNDWATER MANAGEMENT AREA 13. RESULTS ARE IN ACRE-FEET PER YEAR AND ARE DIVIDED BY COUNTY, RIVER BASIN, AND REGIONAL WATER PLANNING AREA.

County	Regional Water Planning Area	Basin	Year					
			2010	2020	2030	2040	2050	2060
Atascosa	L	Nueces	1,191	1,130	1,082	1,042	1,013	994
Dimmit	L	Nueces	0	0	0	0	0	0
Frio	L	Nueces	729	698	674	650	624	601
Gonzales	L	Guadalupe	3,529	3,529	3,529	3,529	3,529	3,529
		Lavaca	23	23	23	23	23	23
Karnes	L	Guadalupe	0	0	0	0	0	0
		Nueces	0	0	0	0	0	0
		San Antonio	0	0	0	0	0	0
La Salle	L	Nueces	987	987	987	987	987	987
McMullen	N	Nueces	90	90	90	90	90	90
Webb	M	Nueces	0	0	0	0	0	0
		Rio Grande	0	0	0	0	0	0
Wilson	L	Guadalupe	23	20	18	16	14	13
		Nueces	55	49	44	39	34	31
		San Antonio	173	154	137	121	108	97
Zavala	L	Nueces	0	0	0	0	0	0
Total			6,800	6,680	6,584	6,497	6,422	6,365

TABLE 4. MODELED AVAILABLE GROUNDWATER FOR THE CARRIZO-WILCOX, QUEEN CITY, AND SPARTA AQUIFERS SUMMARIZED BY COUNTY IN GROUNDWATER MANAGEMENT AREA 13 FOR EACH DECADE BETWEEN 2010 AND 2060. RESULTS ARE IN ACRE-FEET PER YEAR.

County	Year					
	2010	2020	2030	2040	2050	2060
Atascosa	73,686	74,452	75,964	77,394	79,099	81,004
Bexar	26,278	26,278	26,278	26,278	26,278	26,107
Caldwell	44,850	44,850	44,442	44,442	43,866	43,866
Dimmit	3,359	3,359	3,359	3,359	3,359	3,359
Frio	87,028	84,369	81,830	79,359	76,970	74,614
Gonzales	61,100	70,933	78,934	84,408	84,587	84,587
Guadalupe	10,241	10,833	11,283	13,021	13,541	14,041
Karnes	1,059	1,117	1,182	1,231	1,259	1,280
La Salle	7,442	7,442	7,442	7,442	7,442	7,442
Maverick	2,043	2,043	2,024	1,677	1,570	1,532
McMullen	2,045	2,045	2,045	2,045	2,045	2,045
Medina	2,568	2,545	2,533	2,533	2,533	2,533
Uvalde	2,971	1,230	828	828	828	828
Webb	916	916	916	916	916	916
Wilson	37,320	38,549	40,107	41,722	43,632	45,780
Zavala	35,859	35,859	35,521	35,388	35,288	34,969
Total	398,765	406,820	414,688	422,043	423,213	424,903

TABLE 5. MODELED AVAILABLE GROUNDWATER FOR THE CARRIZO-WILCOX, QUEEN CITY, AND SPARTA AQUIFERS SUMMARIZED BY RIVER BASIN IN GROUNDWATER MANAGEMENT AREA 13 FOR EACH DECADE BETWEEN 2010 AND 2060. RESULTS ARE IN ACRE-FEET PER YEAR.

Basin	Year					
	2010	2020	2030	2040	2050	2060
Colorado	593	593	593	593	593	593
Guadalupe	114,912	125,378	133,477	140,744	140,930	141,502
Lavaca	273	273	273	273	273	273
Nueces	237,214	233,700	232,100	230,805	230,236	229,708
Rio Grande	2,196	2,196	2,177	2,135	2,028	1,990
San Antonio	43,577	44,680	46,068	47,493	49,153	50,837
Total	398,765	406,820	414,688	422,043	423,213	424,903

TABLE 6. MODELED AVAILABLE GROUNDWATER FOR THE CARRIZO-WILCOX, QUEEN CITY, AND SPARTA AQUIFERS SUMMARIZED BY REGIONAL WATER PLANNING AREA IN GROUNDWATER MANAGEMENT AREA 13 FOR EACH DECADE BETWEEN 2010 AND 2060. RESULTS ARE IN ACRE-FEET PER YEAR.

Regional Water	Year					
	2010	2020	2030	2040	2050	2060
L	393,761	401,816	409,703	417,405	418,682	420,410
M	2,959	2,959	2,940	2,593	2,486	2,448
N	2,045	2,045	2,045	2,045	2,045	2,045
Total	398,765	406,820	414,688	422,043	423,213	424,903

TABLE 7. MODELED AVAILABLE GROUNDWATER FOR THE CARRIZO-WILCOX, QUEEN CITY, AND SPARTA AQUIFERS SUMMARIZED BY GROUNDWATER CONSERVATION DISTRICT (GCD) IN GROUNDWATER MANAGEMENT AREA 13 FOR EACH DECADE BETWEEN 2010 AND 2060. RESULTS ARE IN ACRE-FEET PER YEAR. UWCD REFERS TO UNDERGROUND WATER CONSERVATION DISTRICT.

Groundwater Conservation District	Year					
	2010	2020	2030	2040	2050	2060
Evergreen UWCD	199,093	198,487	199,083	199,706	200,960	202,678
Gonzales County UWCD*	86,846	96,679	104,680	110,154	110,333	110,333
Guadalupe County	10,241	10,833	11,283	13,021	13,541	14,041
McMullen	2,045	2,045	2,045	2,045	2,045	2,045
Medina County	2,568	2,545	2,533	2,533	2,533	2,533
Plum Creek	18,122	18,122	17,714	17,714	17,138	17,138
Uvalde County UWCD	2,971	1,230	828	828	828	828
Wintergarden	46,660	46,660	46,322	46,189	46,089	45,770
Total (excluding non-district areas)	368,546	376,601	384,488	392,190	393,467	395,366
No District	30,219	30,219	30,200	29,853	29,746	29,537
Total (including non-district areas)	398,765	406,820	414,688	422,043	423,213	424,903

*Note: Gonzales County UWCD includes area in Caldwell County

Appendix A

Estimates of total pumping split by aquifer layers for Groundwater Conservation
Districts

Evergreen Underground Water Conservation District		Year					
	Unit or Layer	2010	2020	2030	2040	2050	2060
Pumping	Sparta	2,171	2,051	1,955	1,868	1,793	1,736
	Queen City	10,803	10,468	10,126	9,735	9,369	9,030
	Carrizo	151,373	151,222	152,256	153,357	155,052	157,166
	Wilcox (Layer 6)	375	375	375	375	375	375
	Wilcox (Layer 7)	371	371	371	371	371	371
	Wilcox (Layer 8)	34,000	34,000	34,000	34,000	34,000	34,000
	Total		199,093	198,487	199,083	199,706	200,960

Gonzales County Underground Water Conservation District		Year					
	Unit or Layer	2010	2020	2030	2040	2050	2060
Pumping	Sparta	3,552	3,552	3,552	3,552	3,552	3,552
	Queen City	5,349	5,349	5,349	5,349	5,349	5,349
	Carrizo	45,884	55,717	63,718	69,192	69,371	69,371
	Wilcox (Layer 6)	0	0	0	0	0	0
	Wilcox (Layer 7)	12,159	12,159	12,159	12,159	12,159	12,159
	Wilcox (Layer 8)	19,902	19,902	19,902	19,902	19,902	19,902
	Total		86,846	96,679	104,680	110,154	110,333

Guadalupe County Groundwater Conservation District		Year					
	Unit or Layer	2010	2020	2030	2040	2050	2060
Pumping	Carrizo	5,500	6,239	6,689	8,427	9,000	9,500
	Wilcox (Layer 6)	0	0	0	0	0	0
	Wilcox (Layer 7)	3,194	3,047	3,047	3,047	2,994	2,994
	Wilcox (Layer 8)	1,547	1,547	1,547	1,547	1,547	1,547
	Total		10,241	10,833	11,283	13,021	13,541

GAM Run 10-012 MAG: Modeled Available Groundwater for the Carrizo-Wilcox, Queen City, and Sparta Aquifers in Groundwater Management Area 13

August 2, 2012

Page 18 of 19

McMullen Groundwater Conservation District		Year					
	Unit or Layer	2010	2020	2030	2040	2050	2060
Pumping	Sparta	90	90	90	90	90	90
	Queen City	136	136	136	136	136	136
	Carrizo	1,819	1,819	1,819	1,819	1,819	1,819
	Total	2,045	2,045	2,045	2,045	2,045	2,045

Medina County Groundwater Conservation District		Year					
	Unit or Layer	2010	2020	2030	2040	2050	2060
Pumping	Carrizo	400	400	400	400	400	400
	Wilcox (Layer 6)	0	0	0	0	0	0
	Wilcox (Layer 7)	1,248	1,248	1,248	1,248	1,248	1,248
	Wilcox (Layer 8)	920	897	885	885	885	885
	Total	2,568	2,545	2,533	2,533	2,533	2,533

Plum Creek Conservation District		Year					
	Unit or Layer	2010	2020	2030	2040	2050	2060
Pumping	Queen City	22	22	22	22	22	22
	Carrizo	3,498	3,498	3,498	3,498	3,498	3,498
	Wilcox (Layer 6)	0	0	0	0	0	0
	Wilcox (Layer 7)	4,869	4,869	4,869	4,869	4,293	4,293
	Wilcox (Layer 8)	9,733	9,733	9,325	9,325	9,325	9,325
	Total	18,122	18,122	17,714	17,714	17,138	17,138

Uvalde County Underground Water Conservation District		Year					
	Unit or Layer	2010	2020	2030	2040	2050	2060
Pumping	Carrizo	828	828	828	828	828	828
	Wilcox (Layer 6)	2,143	402	0	0	0	0
	Total	2,971	1,230	828	828	828	828

Wintergarden Groundwater Conservation District		Year					
	Unit or Layer	2010	2020	2030	2040	2050	2060
Pumping	Sparta	987	987	987	987	987	987
	Queen City	1	1	1	1	1	1
	Carrizo	31,990	31,990	31,652	31,519	31,419	31,100
	Wilcox (Layer 6)	9,259	9,259	9,259	9,259	9,259	9,259
	Wilcox (Layer 7)	4,007	4,007	4,007	4,007	4,007	4,007
	Wilcox (Layer 8)	416	416	416	416	416	416
	Total	46,660	46,660	46,322	46,189	46,089	45,770

Appendix E

TWDB GAM Task 13-036 (Revised): Total Estimated Recoverable Storage for Aquifers in Groundwater Management Area 13

GAM TASK 13-036 (REVISED): TOTAL ESTIMATED RECOVERABLE STORAGE FOR AQUIFERS IN GROUNDWATER MANAGEMENT AREA 13

by Shirley Wade, Ph.D., P.G. and Robert Bradley, P.G.
Texas Water Development Board
Groundwater Resources Division
(512) 936-0883
July 15, 2013

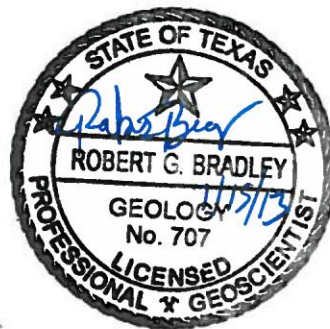
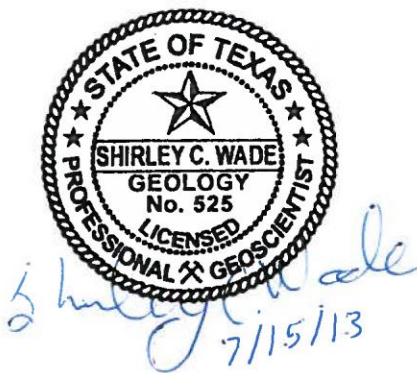

The seals appearing on this document were authorized by Shirley C. Wade, P.G. 525, and Robert Bradley, P.G. 707 on July 15, 2013.

This page is intentionally blank

GAM TASK 13-036 (REVISED): TOTAL ESTIMATED RECOVERABLE STORAGE FOR AQUIFERS IN GROUNDWATER MANAGEMENT AREA 13

by Shirley Wade, Ph. D., P.G. and Robert Bradley, P.G.
Texas Water Development Board
Groundwater Resources Division
(512) 936-0883
July 15, 2013

EXECUTIVE SUMMARY:

Texas Water Code, §36.108 (d) (Texas Water Code, 2011) states that, before voting on the proposed desired future conditions for a relevant aquifer within a groundwater management area, the groundwater conservation districts shall consider the total estimated recoverable storage as provided by the executive administrator of the Texas Water Development Board (TWDB) along with other factors listed in §36.108 (d). Texas Administrative Code Rule §356.10 (Texas Administrative Code, 2011) defines the total estimated recoverable storage as the estimated amount of groundwater within an aquifer that accounts for recovery scenarios that range between 25 percent and 75 percent of the porosity-adjusted aquifer volume.

This report discusses the methods, assumptions, and results of an analysis to estimate the total recoverable storage for the Trinity, Edwards (Balcones Fault Zone), Carrizo-Wilcox, Queen City, Sparta, Yegua-Jackson, and Gulf Coast (including parts of the Catahoula Formation) aquifers within Groundwater Management Area 13. Tables 1 through 14 summarize the total estimated recoverable storage required by the statute. Figures 2 through 8 indicate the official extent of the aquifers in Groundwater Management Area 13 used to estimate the total recoverable storage.

DEFINITION OF TOTAL ESTIMATED RECOVERABLE STORAGE:

The total estimated recoverable storage is defined as the estimated amount of groundwater within an aquifer that accounts for recovery scenarios that range between 25 percent and 75 percent of the porosity-adjusted aquifer volume. In other words, we assume that only 25 to 75 percent of groundwater held within an aquifer can be removed by pumping.

The total recoverable storage was estimated for the portion of the aquifer within the official lateral aquifer boundaries as delineated by George and others (2011). Total estimated recoverable storage values may include a mixture of water quality types, including fresh, brackish, and saline groundwater, because the available data and the existing groundwater availability models do not permit the differentiation of different water quality types. These values do not take into account the effects of land surface subsidence, degradation of water quality, or any changes to surface water-groundwater interaction.

METHODS:

To estimate the total recoverable storage of an aquifer, we first calculated the total storage in an aquifer within the official aquifer boundary. The total storage is the volume of groundwater removed by pumping that completely drains the aquifer.

Aquifers can be either unconfined or confined (figure 1). A well screened in an unconfined aquifer will have a water level equal to the water level outside the well or in the aquifer. Thus, unconfined aquifers have water levels within the aquifers. A confined aquifer is bounded by low permeable geologic units at the top and bottom, and the aquifer is under hydraulic pressure above the ambient atmospheric pressure. The water level at a well screened in a confined aquifer will be above the top of the aquifer. As a result, calculation of total storage is also different between unconfined and confined aquifers. For an unconfined aquifer, the total storage is equal to the volume of groundwater removed by pumping that makes the water level fall to the aquifer bottom. For a confined aquifer, the total storage contains two parts. The first part is the groundwater released from the aquifer when the water level falls from above the top of the aquifer to the top of the aquifer. The reduction of hydraulic pressure in the aquifer by pumping causes expansion of groundwater and deformation of aquifer solids. The aquifer is still fully saturated to this point. The second part, just like unconfined aquifer, is the groundwater released from the aquifer when the water level falls from the top to the bottom of the aquifer. Given the same aquifer area and water level drop, the amount of water released in the second part is much greater than the first part. The difference is quantified by two parameters: storativity related to confined aquifer and specific yield related to unconfined aquifer. For example, storativity values range from 10^{-5} to 10^{-3} for most confined aquifers, while the specific yield values can be 0.01 to 0.3

for most unconfined aquifers. The equations for calculating the total storage are presented below:

- for unconfined aquifers

$$Total\ Storage = V_{drained} = Area \times S_y \times (Water\ Level - Bottom)$$

- for confined aquifers

$$Total\ Storage = V_{confined} + V_{drained}$$

- confined part

$$V_{confined} = Area \times [S \times (Water\ Level - Top)]$$

or

$$V_{confined} = Area \times [S_s \times (Top - Bottom) \times (Water\ Level - Top)]$$

- unconfined part

$$V_{drained} = Area \times [S_y \times (Top - Bottom)]$$

where:

- $V_{drained}$ = storage volume due to water draining from the formation (acre-feet)
- $V_{confined}$ = storage volume due to elastic properties of the aquifer and water(acre-feet)
- $Area$ = area of aquifer (acre)
- $Water\ Level$ = groundwater elevation (feet above mean sea level)
- Top = elevation of aquifer top (feet above mean sea level)
- $Bottom$ = elevation of aquifer bottom (feet above mean sea level)
- S_y = specific yield (no units)
- S_s = specific storage (1/feet)
- S = storativity or storage coefficient (no units)

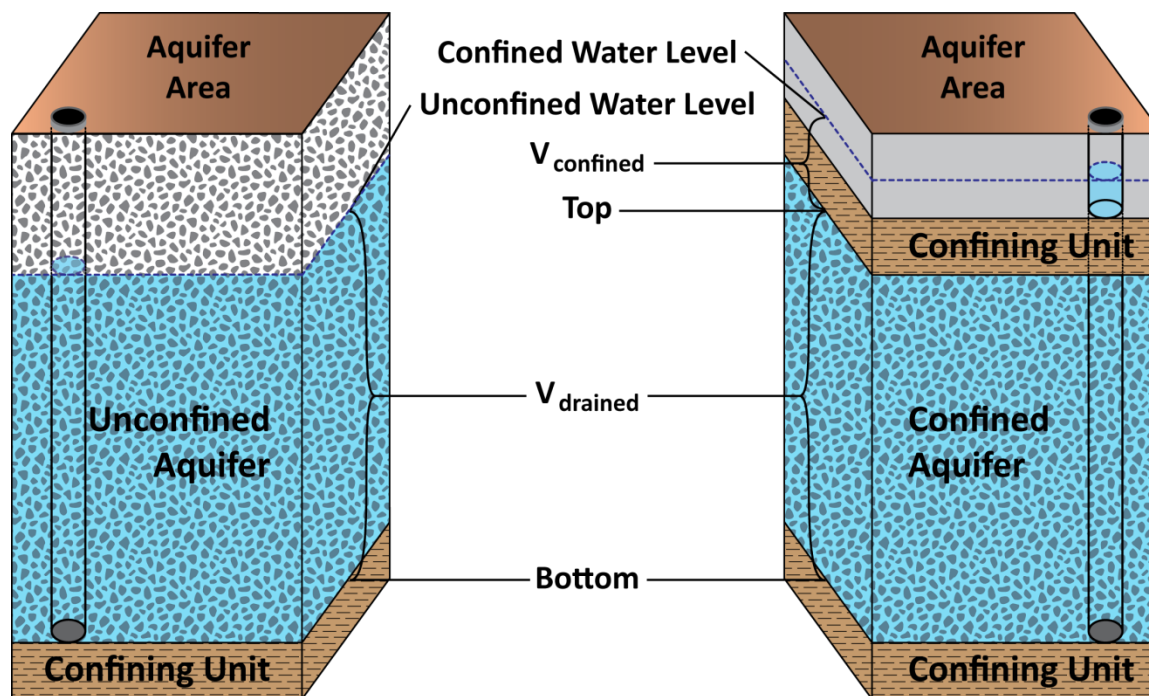

FIGURE 1. SCHEMATIC GRAPH SHOWING THE DIFFERENCE BETWEEN UNCONFINED AND CONFINED AQUIFERS.

As presented in the equations, calculation of the total storage requires data, such as aquifer top, aquifer bottom, aquifer storage properties, and water level. For the Carrizo-Wilcox, Queen City, Sparta, Yegua-Jackson, and Catahoula Formation (part of the Gulf Coast Aquifer System) in Groundwater Management Area 13, we extracted this information from existing groundwater availability model input and output files on a cell-by-cell basis. For aquifers without groundwater availability model(s), an analogous approach is used. For the Trinity Aquifer in Groundwater Management Area 13 we used Surfer[®] software to create surfaces for the water level, top of aquifer, and base of aquifer, using existing data or references. We then used these surfaces to make the volume calculations based on published estimates of storage coefficient and specific yield. Finally, the total recoverable storage was calculated as the product of the total storage and an estimated factor ranging from 25 percent to 75 percent.

PARAMETERS AND ASSUMPTIONS:

Trinity Aquifer

- The Trinity Aquifer within Groundwater Management Area 13 is under confined conditions throughout the area.
- The potentiometric surface is based on the water-level measurements from several sources (Holt, C.L.R, 1956, p.129; Welder and Reeves, 1962, p. 129; TWDB, 2013, and Texas Department of Licensing and Regulation, 2013). Because all of the measurements are located north of the study area and not within the Groundwater Management Area 13 area, an estimate of the head at the southern boundary was made using the head gradient from the available water levels. These estimates were included with the water-level measurements to create a potentiometric surface grid in Surfer® software to calculate the total head above the top of the aquifer.
- We used the base of the San Antonio segment of the Edwards (Balcones Fault Zone) Aquifer from the associated groundwater availability model (Lindgren and others, 2004) as the top of the Trinity Aquifer within the area. The base of the Trinity Aquifer is from Plate 4 in Flawn and others (1961). These surfaces were created as grids in Surfer® software and used to calculate aquifer thickness.
- No storage data was discovered for the area, but because the calculations include all of the Trinity Aquifer as a whole, we used conservative estimates for a storage coefficient of 1×10^{-5} and a specific yield of 0.01 based on Trinity Aquifer references (Johnson, 1967; Jones and others, 2009; Hunt and others, 2010).
- The confined volume is calculated by taking the difference in the potentiometric surface and top of the Trinity Aquifer to estimate total estimated head. This value is multiplied by a storage coefficient of 1×10^{-5} resulting in the total storage volume for the portion above the top of the aquifer.
- The unconfined drained volume is calculated by taking the aquifer thickness and multiplied by a specific yield of 0.01.
- Zonal statistics in ArcMap 10.1 software summed the data from grid calculations by county.

Edwards (Balcones Fault Zone) Aquifer

- We used version 1.01 of the groundwater availability model for the San Antonio segment of the Edwards (Balcones Fault Zone) Aquifer to estimate the total recoverable storage for the aquifer. See Lindgren and others (2004) for assumptions and limitations of the groundwater availability model.
- This groundwater availability model includes one layer which represents the Edwards (Balcones Fault Zone) Aquifer.
- The confined portion of the Edwards (Balcones Fault Zone) Aquifer includes water ranging in total dissolved solids concentration from 250 milligrams per liter (mg/L) to more than 250,000 mg/L (Lindgren and others, 2004). The down-dip boundary of the model is based on the 10,000 mg/L total dissolved solids concentration line and is assumed to represent the limit of groundwater flow in the confined zone of the aquifer (Lindgren and others, 2004).

Carrizo-Wilcox, Queen City, and Sparta aquifers

- We used version 2.01 of the groundwater availability model for the southern part of the Carrizo-Wilcox, Queen City, and Sparta aquifers to estimate the total recoverable storage for the Carrizo-Wilcox, Queen City, and Sparta aquifers. See Deeds and others (2003) and Kelley and others (2004) for assumptions and limitations of the groundwater availability model.
- This groundwater availability model includes eight layers which generally represent the Sparta Aquifer (Layer 1), the Weches Confining Unit (Layer 2), the Queen City Aquifer (Layer 3), the Reklaw Confining Unit (Layer 4), the Carrizo Aquifer (Layer 5), the Upper Wilcox Formation (Layer 6), the Middle Wilcox Formation (Layer 7), and the Lower Wilcox Formation (Layer 8). To develop the estimates for the total estimated recoverable storage, we used Layer 1 (Sparta Aquifer), Layer 3 (Queen City Aquifer), and Layers 5 through 8 (Carrizo-Wilcox Aquifer system).
- The down-dip boundary of the model is based on the location of the Wilcox Growth Fault Zone, which is considered to be a barrier to flow (Kelley and others, 2004). This boundary is relatively deep and in the portion of the aquifer that is characterized as brackish to saline; consequently, the model includes parts of the formation beyond

potable portions of the aquifer. The groundwater in the official extent of the Carrizo-Wilcox, Queen City, and Sparta aquifers ranges from fresh to brackish in composition (Kelley and others, 2004).

Yegua-Jackson Aquifer and the Catahoula Formation portion of the Gulf Coast Aquifer System

- We used version 1.01 of the groundwater availability model for the Yegua-Jackson Aquifer to estimate the total recoverable storages of the Yegua-Jackson Aquifer and parts of the Catahoula Formation. See Deeds and others (2010) for assumptions and limitations of the groundwater availability model.
- This groundwater availability model includes five layers which represent the outcrop section for the Yegua-Jackson Aquifer and the Catahoula Formation and other younger overlying units (Layer 1), the upper portion of the Jackson Group (Layer 2), the lower portion of the Jackson Group (Layer 3), the upper portion of the Yegua Group (Layer 4), and the lower portion of the Yegua Group (Layer 5). To develop the estimates for the total estimated recoverable storage in the Yegua-Jackson Aquifer, we used layers 1 through 5; however, we only used model cells in Layer 1 that represent the outcrop area of the Yegua-Jackson Aquifer. We also used selected model cells in Layer 1 to develop the estimates for the total estimated recoverable storage in the Catahoula Formation, which is considered part of the Gulf Coast Aquifer system, for Zapata County as the groundwater availability models for the Gulf Coast Aquifer System did not fully model this area.
- The down-dip boundary for the Yegua-Jackson Aquifer in this model was set to approximately coincide with the extent of the available geologic data, well beyond any active portion (groundwater use) of the aquifer (Deeds and others, 2010). Consequently, the model extends into zones of brackish and saline groundwater. The groundwater in the official extent of the Yegua-Jackson Aquifer ranges from fresh to brackish in composition (Deeds and others, 2010).

Gulf Coast Aquifer

- We use version 1.01 of the groundwater availability model for the central portion of the Gulf Coast Aquifer System for this analysis for Gonzales County. See Chowdhury and others (2004) and Waterstone and others (2003) for assumptions and limitations of the groundwater availability model.
- The model for the central portion of the Gulf Coast Aquifer System assumes partially penetrating wells in the Evangeline Aquifer due to a lack of data for aquifer properties in the deeper section of the aquifer located closer to the Gulf of Mexico.
- This groundwater availability model includes four layers, which generally represent the Chicot Aquifer (Layer 1), the Evangeline Aquifer (Layer 2), the Burkeville Confining Unit (Layer 3), and the Jasper Aquifer including parts of the Catahoula Formation (Layer 4).
- As depicted by Kalaswad and Arroyo (2006), groundwater in the Gulf Coast Aquifer System ranges from fresh to saline. The reported values in this report for flow terms include fresh (less than 1,000 milligrams per liter total dissolved solids) and brackish (1,000 to 10,000 milligrams per liter total dissolved solids) groundwater.

RESULTS:

Tables 1 through 14 summarize the total estimated recoverable storage required by statute. The county and groundwater conservation district total estimates are rounded to two significant digits. Figure 2 indicates the extent of the Trinity Aquifer in Groundwater Management Area 13 used to estimate the total recoverable storage information. Figures 3 through 8 indicate the extent of the groundwater availability models in Groundwater Management Area 13 for the Edwards (Balcones Fault Zone), Carrizo-Wilcox, Queen City, Sparta, Yegua-Jackson aquifers, and Gulf Coast Aquifer System, from which the storage information was extracted.

TABLE 1. TOTAL ESTIMATED RECOVERABLE STORAGE BY COUNTY FOR THE TRINITY AQUIFER WITHIN GROUNDWATER MANAGEMENT AREA 13. COUNTY TOTAL ESTIMATES ARE ROUNDED TO TWO SIGNIFICANT DIGITS.

<i>County</i>	<i>Total Storage (acre-feet)</i>	<i>25% of Total Storage (acre-feet)</i>	<i>75% of Total Storage (acre-feet)</i>
Atascosa	35,000	8,750	26,250
Bexar	660,000	165,000	495,000
Medina	3,900,000	975,000	2,925,000
Uvalde	110,000	27,500	82,500
Total	4,705,000	1,176,250	3,528,750

TABLE 2. TOTAL ESTIMATED RECOVERABLE STORAGE BY GROUNDWATER CONSERVATION DISTRICT¹ FOR THE TRINITY AQUIFER WITHIN GROUNDWATER MANAGEMENT AREA 13. GROUNDWATER CONSERVATION DISTRICT TOTAL ESTIMATES ARE ROUNDED TO TWO SIGNIFICANT DIGITS.

<i>Groundwater Conservation District (GCD)</i>	<i>Total Storage (acre-feet)</i>	<i>25% of Total Storage (acre-feet)</i>	<i>75% of Total Storage (acre-feet)</i>
No District	660,000	165,000	495,000
Evergreen UWCD ²	35,000	8,750	26,250
Medina County GCD	3,900,000	975,000	2,925,000
Uvalde County UWCD	110,000	27,500	82,500
Total	4,705,000	1,176,250	3,528,750

¹ The total estimated recoverable storage values by groundwater conservation district and county for an aquifer may not be the same because the numbers have been rounded to two significant digits.

² UWCD is the abbreviation for Underground Water Conservation District.

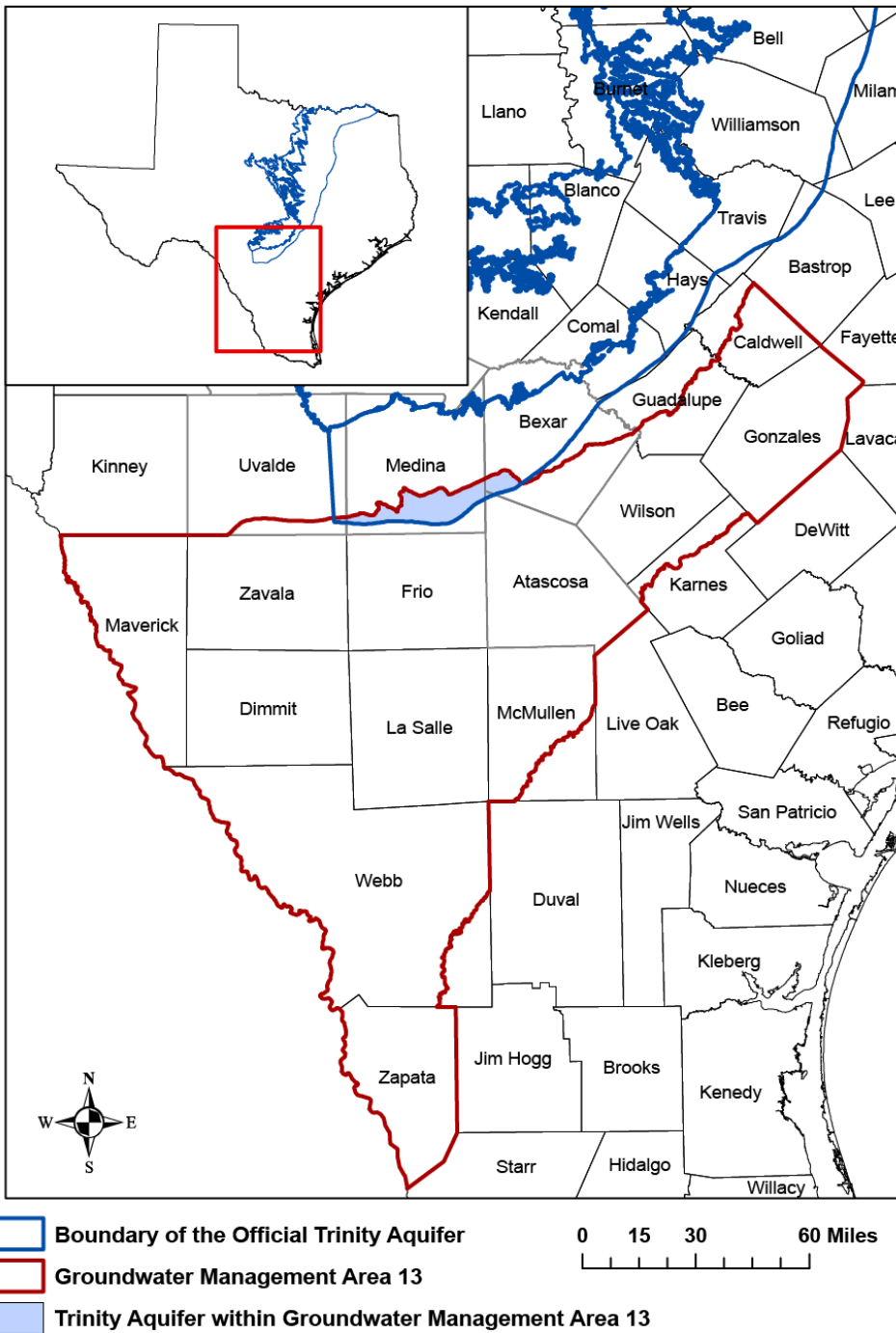

FIGURE 2 AREA OF THE TRINITY AQUIFER USED TO ESTIMATE TOTAL RECOVERABLE STORAGE (TABLES 1 AND 2) WITHIN GROUNDWATER MANAGEMENT AREA 13.

TABLE 3. TOTAL ESTIMATED RECOVERABLE STORAGE BY COUNTY FOR THE EDWARDS (BALCONES FAULT ZONE) AQUIFER WITHIN GROUNDWATER MANAGEMENT AREA 13. COUNTY TOTAL ESTIMATES ARE ROUNDED TO TWO SIGNIFICANT DIGITS.

<i>County</i>	<i>Total Storage (acre-feet)</i>	<i>25% of Total Storage (acre-feet)</i>	<i>75% of Total Storage (acre-feet)</i>
Atascosa	29,000	7,250	21,750
Bexar	130,000	32,500	97,500
Frio	240,000	60,000	180,000
Medina	1,200,000	300,000	900,000
Uvalde	110,000	27,500	82,500
Zavala	9,400	2,350	7,050
Total	1,718,400	429,600	1,288,800

TABLE 4. TOTAL ESTIMATED RECOVERABLE STORAGE BY GROUNDWATER CONSERVATION DISTRICT³ FOR THE EDWARDS (BALCONES FAULT ZONE) AQUIFER WITHIN GROUNDWATER MANAGEMENT AREA 13. GROUNDWATER CONSERVATION DISTRICT TOTAL ESTIMATES ARE ROUNDED TO TWO SIGNIFICANT DIGITS.

<i>Groundwater Conservation District (GCD)</i>	<i>Total Storage (acre-feet)</i>	<i>25% of Total Storage (acre-feet)</i>	<i>75% of Total Storage (acre-feet)</i>
Edwards Aquifer Authority	1,500,000	375,000	1,125,000
Evergreen UWCD ⁴	240,000	60,000	180,000
Wintergarden GCD	9,400	2,350	7,050
Total	1,749,400	437,350	1,312,050

³ The total estimated recoverable storage values by groundwater conservation district and county for an aquifer may not be the same because the numbers have been rounded to two significant digits.

⁴ UWCD is the abbreviation for Underground Water Conservation District.

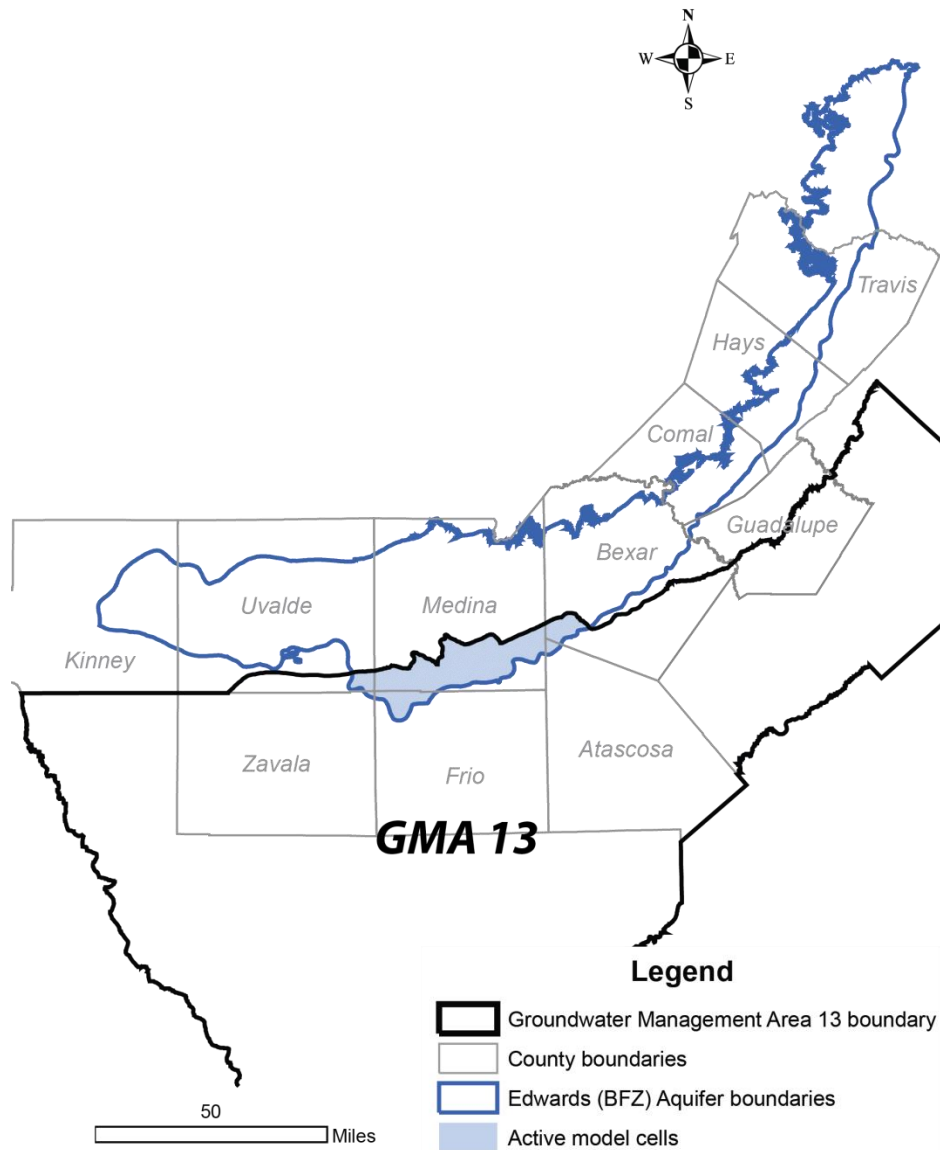

FIGURE 3. EXTENT OF THE GROUNDWATER AVAILABILITY MODEL FOR THE SAN ANTONIO SEGMENT OF THE EDWARDS (BALCONES FAULT ZONE) AQUIFER USED TO ESTIMATE TOTAL RECOVERABLE STORAGE FOR THE EDWARDS (BALCONES FAULT ZONE) AQUIFER (TABLES 3 AND 4) WITHIN GROUNDWATER MANAGEMENT AREA 13.

TABLE 5. TOTAL ESTIMATED RECOVERABLE STORAGE BY COUNTY FOR THE CARRIZO-WILCOX AQUIFER WITHIN GROUNDWATER MANAGEMENT AREA 13. COUNTY TOTAL ESTIMATES ARE ROUNDED TO TWO SIGNIFICANT DIGITS.

<i>County</i>	<i>Total Storage (acre-feet)</i>	<i>25% of Total Storage (acre-feet)</i>	<i>75% of Total Storage (acre-feet)</i>
Atascosa	230,000,000	57,500,000	172,500,000
Bexar	9,000,000	2,250,000	6,750,000
Caldwell	22,000,000	5,500,000	16,500,000
Dimmit	130,000,000	32,500,000	97,500,000
Frio	120,000,000	30,000,000	90,000,000
Gonzales	200,000,000	50,000,000	150,000,000
Guadalupe	18,000,000	4,500,000	13,500,000
Karnes	46,000,000	11,500,000	34,500,000
La Salle	320,000,000	80,000,000	240,000,000
Maverick	1,700,000	425,000	1,275,000
McMullen	250,000,000	62,500,000	187,500,000
Medina	6,200,000	1,550,000	4,650,000
Uvalde	820,000	205,000	615,000
Webb	380,000,000	95,000,000	285,000,000
Wilson	150,000,000	37,500,000	112,500,000
Zavala	68,000,000	17,000,000	51,000,000
Total	1,951,720,000	487,930,000	1,463,790,000

TABLE 6. TOTAL ESTIMATED RECOVERABLE STORAGE BY GROUNDWATER CONSERVATION DISTRICT⁵ FOR THE CARRIZO-WILCOX AQUIFER WITHIN GROUNDWATER MANAGEMENT AREA 13. GROUNDWATER CONSERVATION DISTRICT TOTAL ESTIMATES ARE ROUNDED TO TWO SIGNIFICANT DIGITS.

<i>Groundwater Conservation District (GCD)</i>	<i>Total Storage (acre-feet)</i>	<i>25% of Total Storage (acre-feet)</i>	<i>75% of Total Storage (acre-feet)</i>
No District	400,000,000	100,000,000	300,000,000
Evergreen UWCD	540,000,000	135,000,000	405,000,000
Gonzales County UWCD ⁶	200,000,000	50,000,000	150,000,000
Guadalupe County GCD	18,000,000	4,500,000	13,500,000
McMullen GCD	250,000,000	62,500,000	187,500,000
Medina County GCD	6,200,000	1,550,000	4,650,000
Plum Creek CD ⁷	7,000,000	1,750,000	5,250,000
Uvalde County UWCD	820,000	205,000	615,000
Wintergarden GCD	520,000,000	130,000,000	390,000,000
Total	1,942,020,000	485,505,000	1,456,515,000

⁵ The total estimated recoverable storage values by groundwater conservation district and county for an aquifer may not be the same because the numbers have been rounded to two significant digits.

⁶ UWCD is the abbreviation for Underground Water Conservation District.

⁷ CD is the abbreviation for Conservation District.

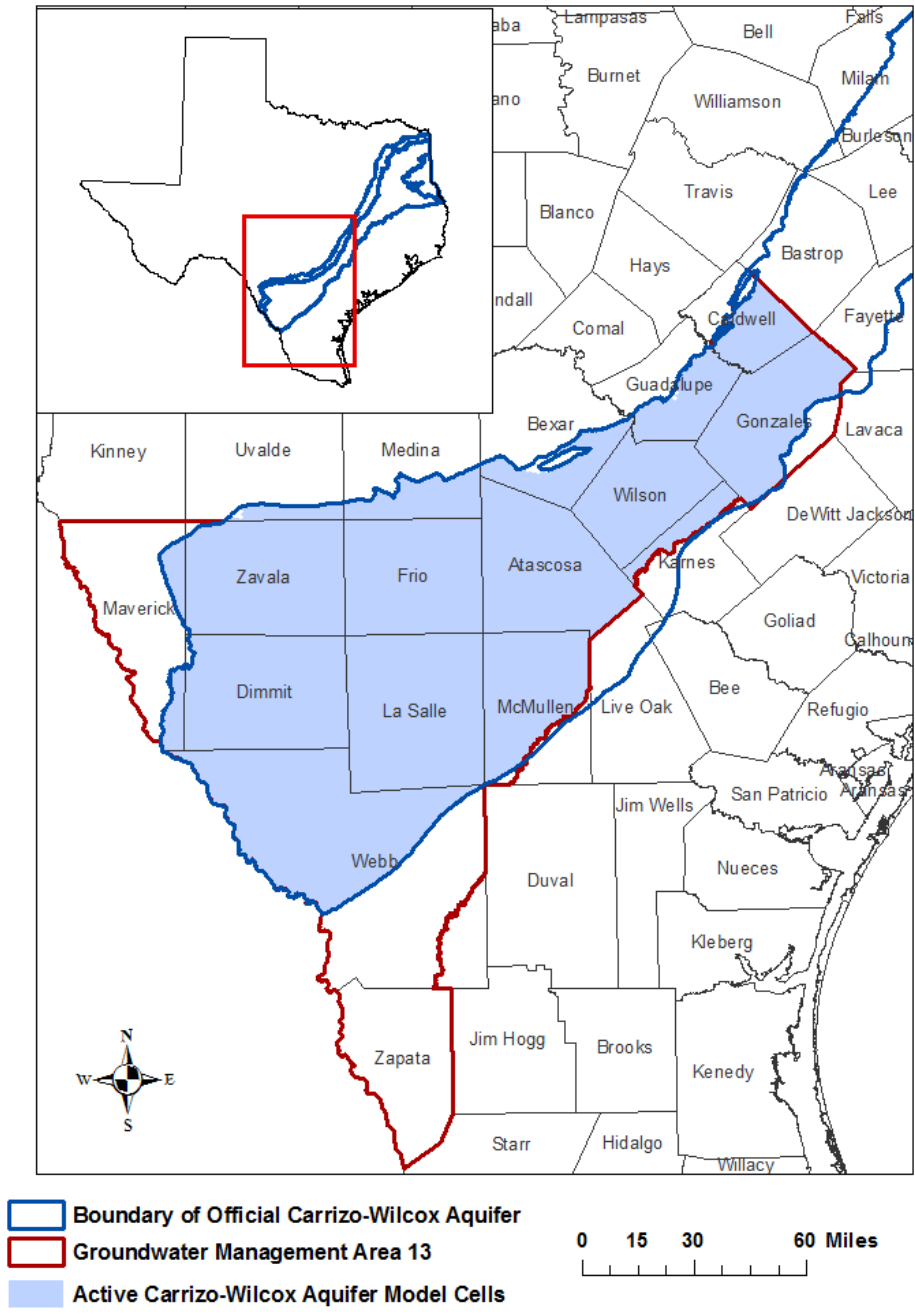

FIGURE 4. EXTENT OF THE GROUNDWATER AVAILABILITY MODEL FOR THE SOUTHERN PART OF THE CARRIZO-WILCOX, QUEEN CITY, AND SPARTA AQUIFERS USED TO ESTIMATE TOTAL RECOVERABLE STORAGE FOR THE CARRIZO-WILCOX AQUIFER (TABLES 5 AND 6) WITHIN GROUNDWATER MANAGEMENT AREA 13.

TABLE 7. TOTAL ESTIMATED RECOVERABLE STORAGE BY COUNTY FOR THE QUEEN CITY AQUIFER WITHIN GROUNDWATER MANAGEMENT AREA 13. COUNTY TOTAL ESTIMATES ARE ROUNDED TO TWO SIGNIFICANT DIGITS.

<i>County</i>	<i>Total Storage (acre-feet)</i>	<i>25% of Total Storage (acre-feet)</i>	<i>75% of Total Storage (acre-feet)</i>
Atascosa	83,000,000	20,750,000	62,250,000
Caldwell	430,000	107,500	322,500
Frio	45,000,000	11,250,000	33,750,000
Gonzales	26,000,000	6,500,000	19,500,000
Guadalupe	2,800	700	2,100
La Salle	15,000,000	3,750,000	11,250,000
McMullen	33,000,000	8,250,000	24,750,000
Wilson	24,000,000	6,000,000	18,000,000
Total	226,432,800	56,608,200	169,824,600

TABLE 8. TOTAL ESTIMATED RECOVERABLE STORAGE BY GROUNDWATER CONSERVATION DISTRICT⁸ FOR THE QUEEN CITY AQUIFER WITHIN GROUNDWATER MANAGEMENT AREA 13. GROUNDWATER CONSERVATION DISTRICT TOTAL ESTIMATES ARE ROUNDED TO TWO SIGNIFICANT DIGITS.

<i>Groundwater Conservation District (GCD)</i>	<i>Total Storage (acre-feet)</i>	<i>25% of Total Storage (acre-feet)</i>	<i>75% of Total Storage (acre-feet)</i>
Evergreen UWCD ⁹	150,000,000	37,500,000	112,500,000
Gonzales County UWCD	26,000,000	6,500,000	19,500,000
Guadalupe County GCD	2,800	700	2,100
McMullen GCD	33,000,000	8,250,000	24,750,000
Plum Creek CD ¹⁰	50,000	12,500	37,500
Wintergarden GCD	15,000,000	3,750,000	11,250,000
Total	224,052,800	56,013,200	168,039,600

⁸ The total estimated recoverable storage values by groundwater conservation district and county for an aquifer may not be the same because the numbers have been rounded to two significant digits.

⁹ UWCD is the abbreviation for Underground Water Conservation District.

¹⁰ CD is the abbreviation for Conservation District.

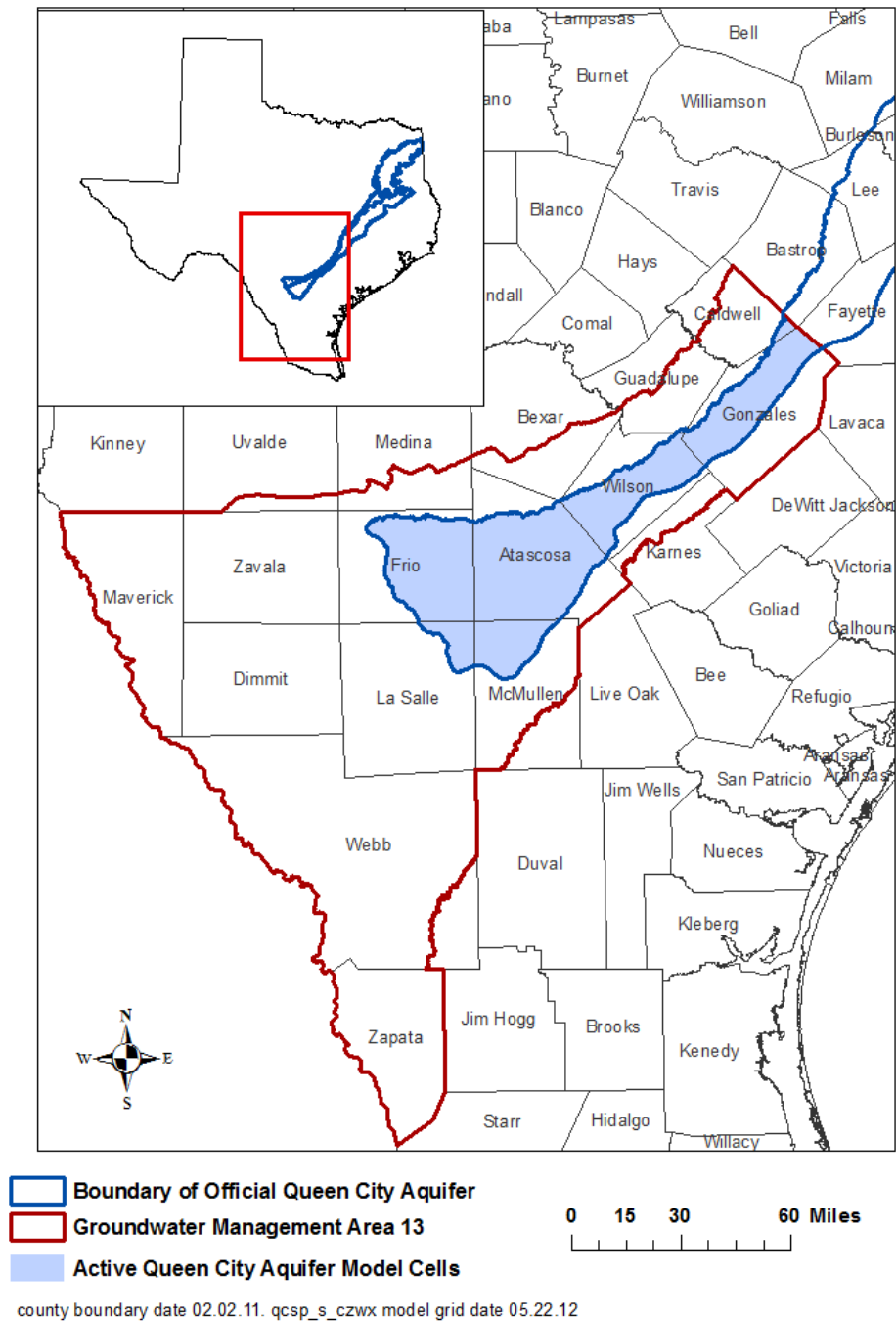

FIGURE 5. EXTENT OF THE GROUNDWATER AVAILABILITY MODEL FOR THE SOUTHERN PART OF THE CARRIZO-WILCOX, QUEEN CITY, AND SPARTA AQUIFERS USED TO ESTIMATE TOTAL RECOVERABLE STORAGE FOR THE QUEEN CITY AQUIFER (TABLES 7 AND 8) WITHIN GROUNDWATER MANAGEMENT AREA 13.

TABLE 9. TOTAL ESTIMATED RECOVERABLE STORAGE BY COUNTY FOR THE SPARTA AQUIFER WITHIN GROUNDWATER MANAGEMENT AREA 13. COUNTY TOTAL ESTIMATES ARE ROUNDED TO TWO SIGNIFICANT DIGITS.

<i>County</i>	<i>Total Storage (acre-feet)</i>	<i>25% of Total Storage (acre-feet)</i>	<i>75% of Total Storage (acre-feet)</i>
Atascosa	12,000,000	3,000,000	9,000,000
Frio	2,600,000	650,000	1,950,000
Gonzales	5,600,000	1,400,000	4,200,000
La Salle	1,600,000	400,000	1,200,000
McMullen	1,700,000	425,000	1,275,000
Wilson	2,500,000	625,000	1,875,000
Total	26,000,000	6,500,000	19,500,000

TABLE 10. TOTAL ESTIMATED RECOVERABLE STORAGE BY GROUNDWATER CONSERVATION DISTRICT¹¹ FOR THE SPARTA AQUIFER WITHIN GROUNDWATER MANAGEMENT AREA 13. GROUNDWATER CONSERVATION DISTRICT TOTAL ESTIMATES ARE ROUNDED TO TWO SIGNIFICANT DIGITS.

<i>Groundwater Conservation District (GCD)</i>	<i>Total Storage (acre-feet)</i>	<i>25% of Total Storage (acre-feet)</i>	<i>75% of Total Storage (acre-feet)</i>
Evergreen UWCD ¹²	17,000,000	4,250,000	12,750,000
Gonzales County UWCD	5,600,000	1,400,000	4,200,000
McMullen GCD	1,700,000	425,000	1,275,000
Wintergarden GCD	1,600,000	400,000	1,200,000
Total	25,900,000	6,475,000	19,425,000

¹¹ The total estimated recoverable storage values by groundwater conservation district and county for an aquifer may not be the same because the numbers have been rounded to two significant digits.

¹² UWCD is the abbreviation for Underground Water Conservation District.

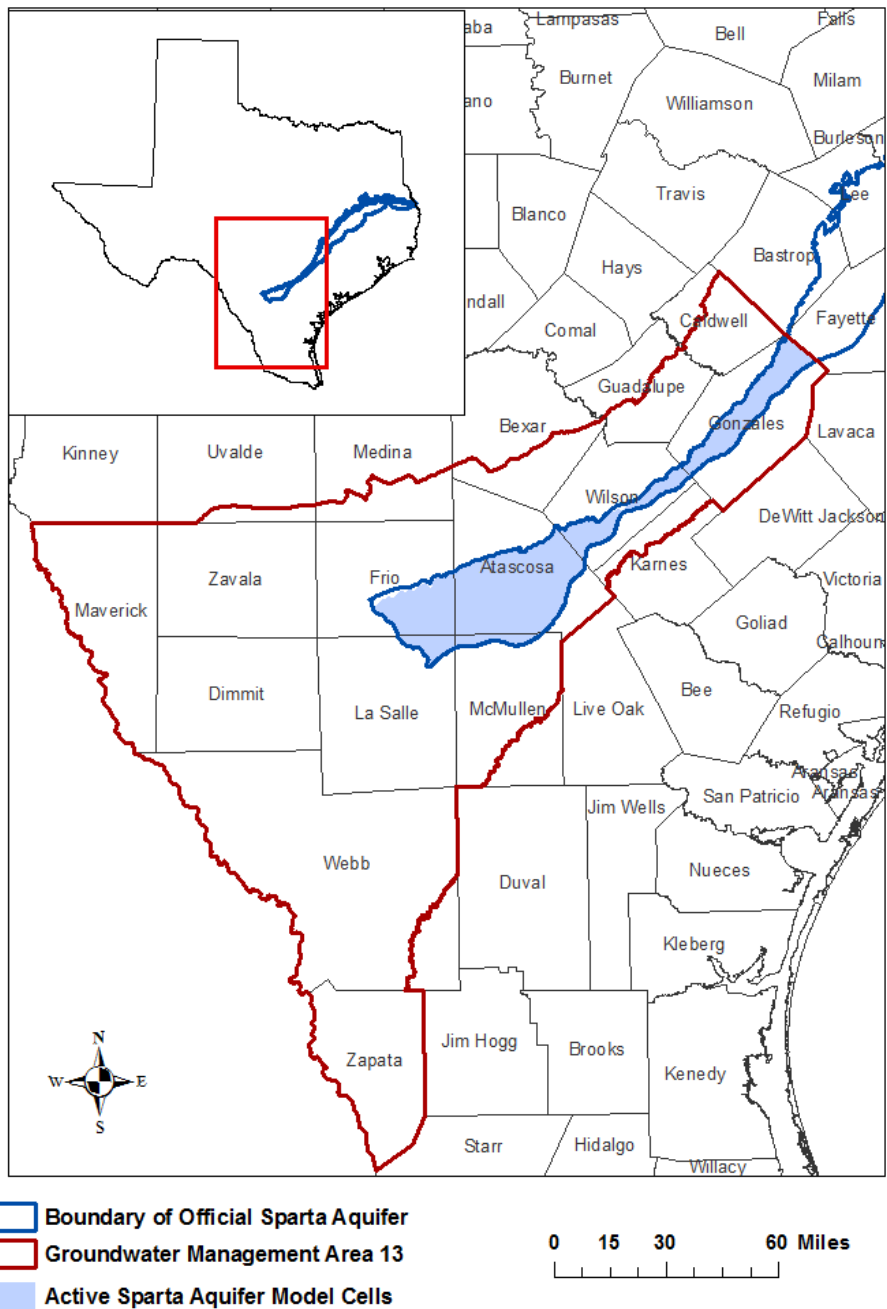

FIGURE 6. EXTENT OF THE GROUNDWATER AVAILABILITY MODEL FOR THE SOUTHERN PART OF THE CARRIZO-WILCOX, QUEEN CITY, AND SPARTA AQUIFERS USED TO ESTIMATE TOTAL RECOVERABLE STORAGE FOR THE SPARTA AQUIFER (TABLES 9 AND 10) WITHIN GROUNDWATER MANAGEMENT AREA 13.

TABLE 11. TOTAL ESTIMATED RECOVERABLE STORAGE BY COUNTY FOR THE YEGUA-JACKSON AQUIFER WITHIN GROUNDWATER MANAGEMENT AREA 13. COUNTY TOTAL ESTIMATES ARE ROUNDED TO TWO SIGNIFICANT DIGITS.

<i>County</i>	<i>Total Storage (acre-feet)</i>	<i>25% of Total Storage (acre-feet)</i>	<i>75% of Total Storage (acre-feet)</i>
Atascosa	40,000,000	10,000,000	30,000,000
Frio	75,000	18,750	56,250
Gonzales	32,000,000	8,000,000	24,000,000
Karnes	19,000,000	4,750,000	14,250,000
La Salle	56,000,000	14,000,000	42,000,000
McMullen	96,000,000	24,000,000	72,000,000
Webb	210,000,000	52,500,000	157,500,000
Wilson	6,800,000	1,700,000	5,100,000
Zapata	83,000,000	20,750,000	62,250,000
Total	542,875,000	135,718,750	407,156,250

TABLE 12. TOTAL ESTIMATED RECOVERABLE STORAGE BY GROUNDWATER CONSERVATION DISTRICT¹³ FOR THE YEGUA-JACKSON AQUIFER WITHIN GROUNDWATER MANAGEMENT AREA 13. GROUNDWATER CONSERVATION DISTRICT TOTAL ESTIMATES ARE ROUNDED TO TWO SIGNIFICANT DIGITS.

<i>Groundwater Conservation District (GCD)</i>	<i>Total Storage (acre-feet)</i>	<i>25% of Total Storage (acre-feet)</i>	<i>75% of Total Storage (acre-feet)</i>
No District	310,000,000	77,500,000	232,500,000
Evergreen UWCD ¹⁴	66,000,000	16,500,000	49,500,000
Gonzales County UWCD	23,000,000	5,750,000	17,250,000
McMullen GCD	96,000,000	24,000,000	72,000,000
Wintergarden GCD	56,000,000	14,000,000	42,000,000
Total	551,000,000	137,750,000	413,250,000

¹³ The total estimated recoverable storages values by groundwater conservation district and county for an aquifer may not be the same because the numbers have been rounded to two significant digits.

¹⁴ UWCD is the abbreviation for Underground Water Conservation District.

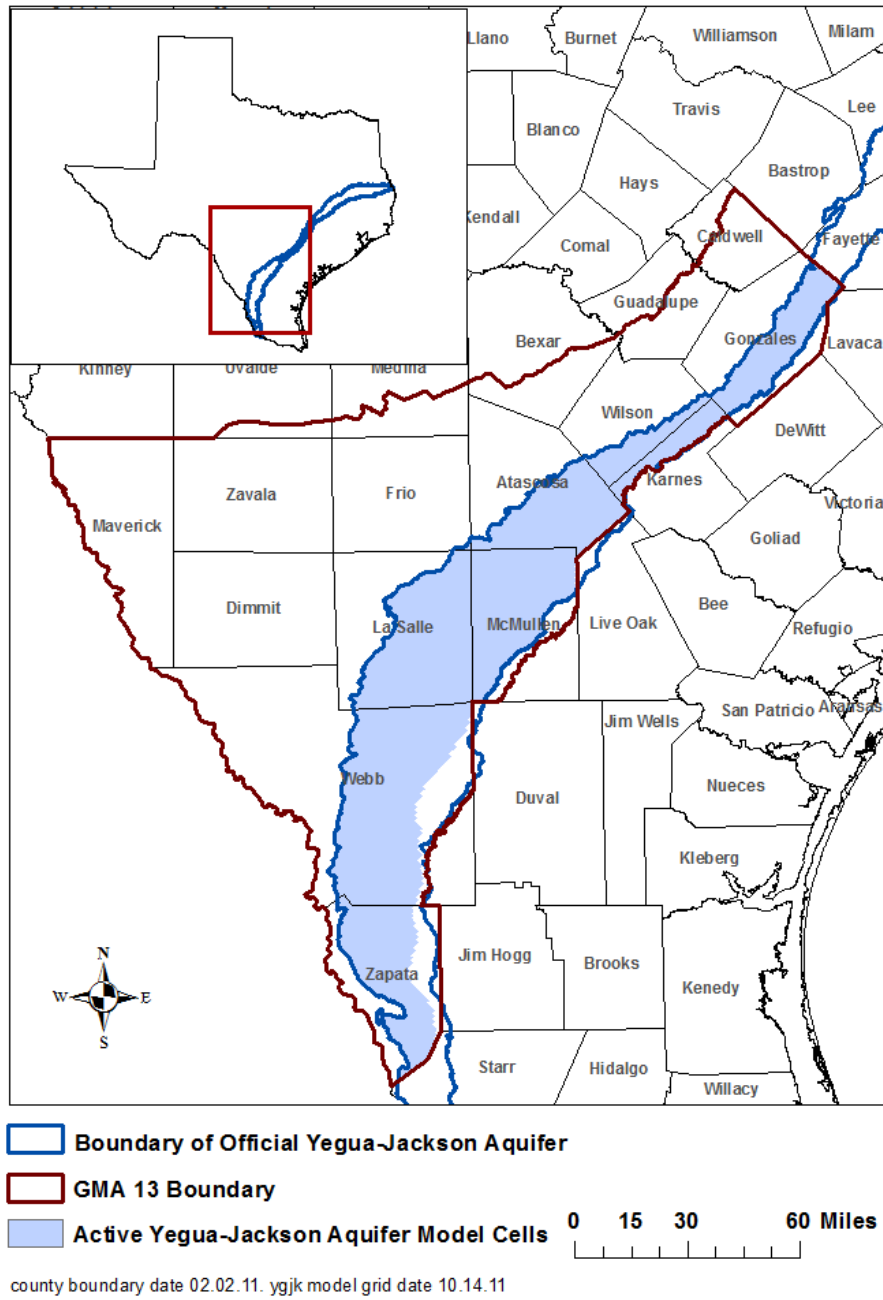

FIGURE 7. EXTENT OF THE GROUNDWATER AVAILABILITY MODEL FOR THE YEGUA-JACKSON AQUIFER USED TO ESTIMATE TOTAL RECOVERABLE STORAGE (TABLES 11 AND 12) FOR THE YEGUA-JACKSON AQUIFER AND CATAHOULA FORMATION PORTION OF THE GULF COAST AQUIFER SYSTEM (TABLES 13 AND 14) WITHIN GROUNDWATER MANAGEMENT AREA 13.

TABLE 13. TOTAL ESTIMATED RECOVERABLE STORAGE BY COUNTY FOR THE GULF COAST AQUIFER SYSTEM¹⁵ WITHIN GROUNDWATER MANAGEMENT AREA 13. COUNTY TOTAL ESTIMATES ARE ROUNDED TO TWO SIGNIFICANT DIGITS.

<i>County</i>	<i>Total Storage (acre-feet)</i>	<i>25% of Total Storage (acre-feet)</i>	<i>75% of Total Storage (acre-feet)</i>
Gonzales	360,000	90,000	270,000
Zapata	2,100,000	525,000	1,575,000
Total	2,460,000	615,000	1,845,000

TABLE 14. TOTAL ESTIMATED RECOVERABLE STORAGE BY GROUNDWATER CONSERVATION DISTRICT¹⁶ FOR THE GULF COAST AQUIFER SYSTEM WITHIN GROUNDWATER MANAGEMENT AREA 13. GROUNDWATER CONSERVATION DISTRICT TOTAL ESTIMATES ARE ROUNDED TO TWO SIGNIFICANT DIGITS.

<i>Groundwater Conservation District</i>	<i>Total Storage (acre-feet)</i>	<i>25% of Total Storage (acre-feet)</i>	<i>75% of Total Storage (acre-feet)</i>
No District	2,410,000	602,500	1,807,500
Gonzales County UWCD ¹⁷	51,000	12,750	38,250
Total	2,461,000	615,250	1,845,750

¹⁵ Estimates for Zapata County are from the Catahoula portion of Layer 1 in the Groundwater Availability Model for the Yegua-Jackson Aquifer.

¹⁶ The total estimated recoverable storage values by groundwater conservation district and county for an aquifer may not be the same because the numbers have been rounded to two significant digits.

¹⁷ UWCD is the abbreviation for Underground Water Conservation District.

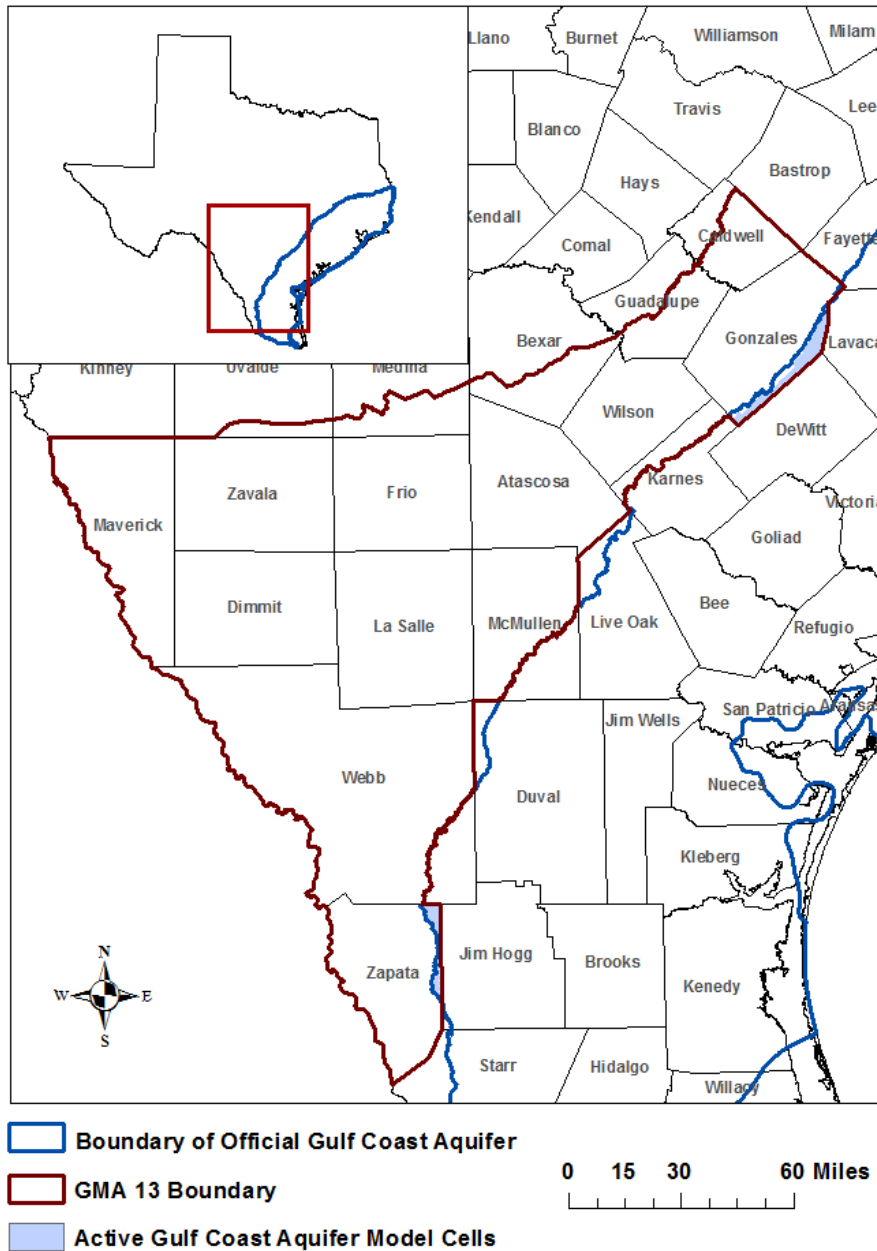

county boundary date 02.02.11. yjgk model grid date 10.14.11 glfc_c model grid date 10.13.11

FIGURE 8. EXTENT OF THE GROUNDWATER AVAILABILITY MODELS FOR THE YEGUA-JACKON (CATAHOULA IN LAYER 1) AND CENTRAL PORTION OF THE GULF COAST AQUIFER USED TO ESTIMATE TOTAL RECOVERABLE STORAGE (TABLES 13 AND 14) FOR THE GULF COAST AQUIFER WITHIN GROUNDWATER MANAGEMENT AREA 13.

LIMITATIONS

The groundwater models used in completing this analysis are the best available scientific tools that can be used to meet the stated objective(s). To the extent that this analysis will be used for planning purposes and/or regulatory purposes related to pumping in the past and into the future, it is important to recognize the assumptions and limitations associated with the use of the results. In reviewing the use of models in environmental regulatory decision making, the National Research Council (2007) noted:

“Models will always be constrained by computational limitations, assumptions, and knowledge gaps. They can best be viewed as tools to help inform decisions rather than as machines to generate truth or make decisions. Scientific advances will never make it possible to build a perfect model that accounts for every aspect of reality or to prove that a given model is correct in all respects for a particular regulatory application. These characteristics make evaluation of a regulatory model more complex than solely a comparison of measurement data with model results.”

Because the application of the groundwater model was designed to address regional scale questions, the results are most effective on a regional scale. The TWDB makes no warranties or representations relating to the actual conditions of any aquifer at a particular location or at a particular time.

REFERENCES:

- Deeds, N., Kelley, V., Fryar, D., Jones, T., Whallon, A.J., and Dean, K.E., 2003, Groundwater Availability Model for the Southern Carrizo-Wilcox Aquifer: Contract report to the Texas Water Development Board, 452 p.,
http://www.twdb.texas.gov/groundwater/models/gam/czwx_s/CZWX_S_Full_Report.pdf.
- Deeds, N.E., Yan, T., Singh, A., Jones, T.L., Kelley, V.A., Knox, P.R., Young, S.C., 2010, Groundwater availability model for the Yegua-Jackson Aquifer: Final report prepared for the Texas Water Development Board by INTERA, Inc., 582 p.,
http://www.twdb.texas.gov/groundwater/models/gam/ygjk/YGJK_Model_Report.pdf.
- Flawn, P.T., Goldstein, A, King, P.B., and Weaver, C.E., 1961, The Ouachita System, University of Texas at Austin, Bureau of Economic Geology, Publication No. 6120 Plate 4, 401 p.

- George, P.G., Mace, R.E., and Petrossian, R, 2011, Aquifers of Texas, Texas Water Development Board Report 380,
<http://www.twdb.texas.gov/groundwater/aquifer/index.asp>
- Holt, C.L.R., 1956, Geology and ground-water resources of Medina County, Texas Board of Water Engineers, Bulletin 5601, 278 p.
- Hunt, B. B, Smith, B.A., Kromann, J, Wiereman, D.A, and Mikels, J.K., 2010, Compilation of pumping tests in Travis and Hays Counties, Central Texas, Barton Springs/Edwards Aquifer Conservation District Data Series Report 2010-0701, p.
- Johnson, A.I., 1967, Specific yield - compilation of specific yields for various materials, U.S. Geological Survey, Water Supply Paper 1662-D, 74p.
- Jones, I.C., Anaya, R. and Wade, S., 2009, Groundwater Availability Model for the Hill Country portion of the Trinity Aquifer System, Texas, Texas Water Development Board unpublished report, 193 p.
- Kalaswad, S., and Arroyo, J., 2006, Status report on brackish groundwater and desalination in the Gulf Coast Aquifer of Texas *in* Mace, R.E., Davison, S.C., Angle, E.S., and Mullican, III, W.F., eds., Aquifers of the Gulf Coast of Texas: Texas Water Development Board Report 365, p. 231-240.,
http://www.twdb.texas.gov/publications/reports/numbered_reports/doc/R365/R365_Composite.pdf
- Kelley, V.A., Deeds, N.E., Fryar, D.G., and Nicot, J.P., 2004, Groundwater availability models for the Queen City and Sparta aquifers: Contract report to the Texas Water Development Board, 867 p.,
http://www.twdb.texas.gov/groundwater/models/gam/qcsp/QCSP_Model_Report.pdf
- .
- Lindgren, R.J., Dutton, A.R, Hovorka, S.D., Worthington, S.R.H., and Painter, S., Conceptualization and simulation of the Edwards Aquifer, San Antonio Region, Texas, U. S. Geological Survey, Scientific Investigations Report 2004-5277
- National Research Council, 2007, Models in Environmental Regulatory Decision Making Committee on Models in the Regulatory Decision Process, National Academies Press, Washington D.C., 287 p., http://www.nap.edu/catalog.php?record_id=11972.
- Texas Department of Licensing and Regulation, 2013, Texas Well Record Submission and Retrieval System: Texas Department of Licensing and Regulation, Water Well and Pump Installers program.
- Texas Administrative Code, 2011, [http://info.sos.state.tx.us/pls/pub/readtac\\$ext.viewtac](http://info.sos.state.tx.us/pls/pub/readtac$ext.viewtac)
- Texas Water Code, 2011, <http://www.statutes.legis.state.tx.us/docs/WA/pdf/WA.36.pdf>
- Texas Water Development Board, 2013, Groundwater database: Texas Water Development Board, Water Science and Conservation Division.

GAM Task 13-036 (Revised): Total Estimated Recoverable Storage for Aquifers in Groundwater Management Area 13
July 15, 2013
Page 30 of 30

Welder, F.A. and Reeves, R.D., 1962, Geology and Ground-water resources of Uvalde County, Texas, Texas Water Commission, Bulletin 6212, 252 p.

Appendix F

**Paper authored by James Bene of R.W. Harden & Associates
regarding the Joint Planning Process**

Refining the DFC-MAG Approach: Selecting Successful DFCs

By James Bené, P.G.

(Principal, R.W. Harden & Associates, Inc., 3409 Executive Center Dr., Suite 226, Austin, Texas 78731, 512-345-2379)

The “Desired Future Condition” (DFC) “Modeled Available Groundwater” (MAG) management process is a relative newcomer to water planning in Texas. Like any new strategy, it begins as a general concept that evolves and improves over time. In order for the DFC/MAG process to be successful and enduring, DFCs should be adopted that embody clear goals. Ideally, these goals should offer assurances to stakeholders that the State’s aquifers and environment are being protected without unreasonably impeding the use of groundwater supplies.

Many Groundwater Management Areas (GMAs) have adopted DFCs based on “drawdown” predicted by groundwater models. This approach is simple in concept, but carries with it several disadvantages. DFCs can be improved by shifting the focus away from groundwater modeling and “drawdown”, in general. Alternative DFCs are proposed herein, which are based on managing: 1) the amount of groundwater in an aquifer through time and 2) unique hydrologic features or effects, such as springflow or subsidence.

It is hoped that adoption of reconsidered DFCs will improve the DFC/MAG process by providing a clear, consistent regulatory framework on which to base water management decisions. The following sections discuss some of the key issues underlying the selection of successful DFCs including:

- The drawbacks associated with the current DFCs
- The difference between the two types of aquifer “drawdown”
- The important properties of a good DFC
- Several reasons why neither type of “drawdown” should be used as a DFC
- Potential, alternative DFCs

The Downside of the Current DFCs

In order to appreciate why alternative DFCs might be beneficial, it is important to recognize the drawbacks associated with the current DFCs, which are often defined by the results of groundwater model simulations. Typically, estimated pumpage was input into a model, simulations were run, and the modeled water level declines (“drawdowns”) were adopted as DFCs. This approach appears straightforward, but there are significant shortcomings associated with it.

One readily-apparent problem with using models as DFCs is that the simulated impacts are driven by the pumpage data input into the model. In many instances, those inputs represent “educated guesses” regarding the location and rates of pumpage in a GMA over the next 50 years. Clearly, the input pumpage data will be incorrect to some unknown extent. Consequently, the DFCs generated using that data will also incorporate an indeterminate amount of error, which is

obviously undesirable. More importantly, DFCs defined using pumpage estimates result in MAG values that correspond to forecasted pumpage rather than the physical availability of groundwater. This can result in confusion as to the actual extent of aquifer resources and improper and/or ineffective water planning.

Linking DFCs to unique simulations also creates less-obvious problems for water planners and stakeholders. For example, the current DFC selection process creates a regulatory feedback loop that has the potential to impede responsible groundwater development over the coming years. The loop begins with the adoption of DFCs based on model results that reflect relatively arbitrary model pumpage inputs. Those DFC pumpage inputs then become MAGs and are inserted into the regional water planning process as the amount of available groundwater. The availability limits then directly influence the selection of water management strategies to be incorporated in the State Water Plan. Consequently, a groundwater project that was not included in the DFC model pumpage inputs will be less likely to be recognized as a desirable strategy. The loop is completed at the groundwater conservation district level, where State Water Plan strategies are considered during permitting decisions and the development of management plans.

One other common and very significant shortcoming of many current DFCs is that they are often defined as an amount of generic water level decline (“drawdown”) over time. There are several reasons why drawdown is not a desirable DFC criterion which are discussed herein, but first it is important to understand that not all drawdowns are created equal. Aquifers react differently depending on the location of pumpage because groundwater flow is controlled by the structure of the aquifer and the formations surrounding it. The following sections discuss how the configuration and makeup of Texas’ aquifers affect the meaning of drawdown.

What is Drawdown?

Figure 1 is a generalized cross-section of typical eastern Texas aquifers such as the Trinity, Carrizo-Wilcox, and Gulf Coast aquifers. The productive portions of these aquifers commonly consist of quartz sand beds through which groundwater flows in the pore spaces between sand grains.

Aquifer recharge occurs primarily through downward percolation of precipitation in areas where aquifer beds outcrop at the land surface. The recharge migrates downward until it reaches the top of the saturated aquifer materials, which is commonly called a “water table”. After the recharge water reaches the water table, it slowly travels through the aquifer beds, which dip toward the southeast at up to about 200 feet per mile. In these deeper, down-dip zones, the flow is confined within the sand-rich aquifer beds by clay-rich, relatively impermeable beds that lie above and below the aquifer. As a result, groundwater is under “artesian” pressure that pushes water levels above the top of the aquifer in wells completed in down-dip aquifer zones.

Drawdown in water table areas is fundamentally different from drawdown in deeper, artesian portions of the aquifer. When a well is pumped in an outcrop area, water level declines are transmitted outward from the well, forming a “cone of depression” in the water table. Stated another way, pumpage in water table areas drains water from aquifer pore spaces, which reduces the saturated thickness of the aquifer near the well. Wells completed in artesian aquifer zones behave very differently. Drawdown in a well completed in an artesian zone is transmitted outward from the well in the form of a reduction in artesian pressure. The artesian pressure

declines spread relatively quickly and over larger areas than water table drawdown because very little physical flow of water is needed to transmit changes in groundwater pressure. Unlike water table wells, aquifer materials remain fully saturated near artesian wells as long as groundwater pressure levels remain above the top of the aquifer.

Figure 1: Cross-Sectional Aquifer Diagram

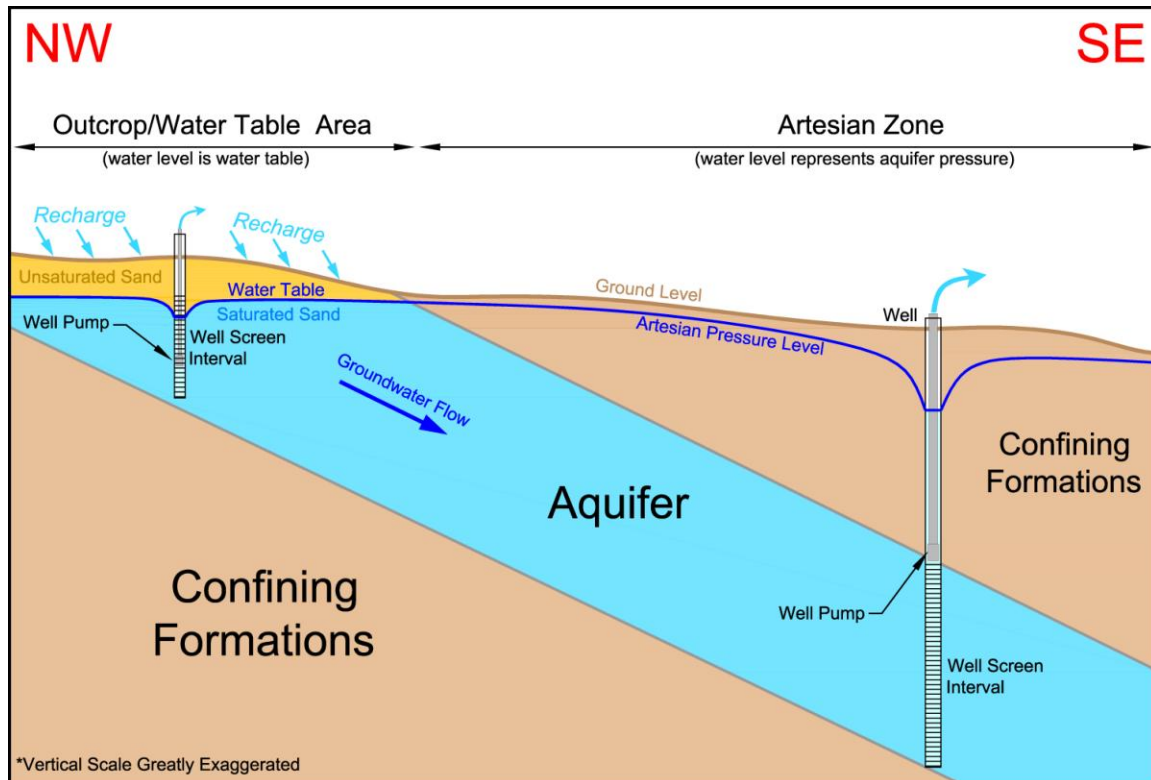

Interpreting Drawdown

As discussed below, both water table and artesian pressure levels should be avoided as DFCs; however, they can be useful indicators when evaluated in the appropriate hydrologic context. From an aquifer management standpoint, water table levels are generally much more useful than artesian pressures. There are several practical reasons why this is so that stem from the physical difference between the two types of aquifer response. To summarize, changes in water table levels occur through filling or drainage of aquifer pore spaces, while changes in artesian pressure levels result from fluctuations in groundwater pressure.

Because water must be physically drained from void spaces in the aquifer materials, much more pumpage is required to cause one foot of water table decline than is needed to cause one foot of artesian pressure decline within an area. The difference between water table and artesian pressure volumes varies with the type of aquifer material, but the ratio is typically 1,000 times or more. In other words, an average artesian pressure drawdown of 100 feet is equal in volume to an average decline of 1/10-foot in water table levels over an equivalent area. When applied to aquifer structure and thickness data, water table levels provide a relatively straightforward measure of the amount of water in an aquifer, while artesian pressure levels do not.

Water table levels are also more useful for evaluating many environmental effects. Biological environments and habitats that rely on groundwater depend on sufficiently high water table levels to maintain adequate outflows to springs, seeps, and/or streams. In conjunction with other factors such as aquifer structure, composition, and hydraulic boundaries, water table levels play an important role in managing surface/groundwater flow. Artesian pressures also affect groundwater flow to surface features, but only through their subdued influence on water table levels.

Historical well records indicate that, in general, changes in water table levels progress at a slow, steady pace. In contrast, large, short-term fluctuations in artesian pressure levels are common in Texas' aquifers as pumpage rates change in response to seasonal demands or individual well pumping cycles. Monitoring of slow, steady water table declines is preferred because it allows regulators and stakeholders enough time to carefully respond to changes in aquifer conditions.

What makes a good DFC?

Texas has been and continues to be relatively progressive with respect to collecting, analyzing, modeling, and distributing groundwater data. We have a long-term record of the changes in groundwater systems throughout the State, which allows us to be comparatively confident in our predictions. Nevertheless, groundwater regulations ought to be structured to provide safeguards against unexpected, adverse effects in case we are wrong about how our aquifers will behave in the future.

Experience suggests that the core motivation for regulating groundwater use is the common desire to prevent three basic types of unwanted impacts:

- **Resource Depletion** – Will there be enough groundwater for future needs?
- **Environmental Impacts** – Will pumping harm the hydrogeologic system or ecosystems that depend on groundwater? Will pumping cause significant subsidence in low-lying areas?
- **Economic Impacts** – Will the use of groundwater cause an undue financial burden on stakeholders? What are the costs of promoting or limiting economic development in a region?

Good DFCs will account for all of these factors and will focus on addressing clearly-defined, well-documented goals. In keeping with the principle of “Occam’s Razor”, which tells us that the simplest solution is usually the correct one, it is also desirable that DFCs be defined as plainly and concisely as possible. From a practical standpoint, there should be simple methods for verifying that DFC goals are being met in the real world. It is also important that a DFC be structured in a way that promotes fair and impartial regulation for all groundwater owners.

Drawdown is NOT a good DFC

Neither water table nor artesian pressure drawdowns make good DFCs. While monitoring both types of declines is informative, there are more-straightforward criteria that can be used when defining DFCs. The following sections discuss why using drawdown (in either form) to control aquifer depletion, environmental impacts, and/or economic costs is not the best way to manage Texas' aquifers.

Managing Groundwater Availability and the Environment with Drawdown

Artesian pressure declines do not have a meaningful impact on aquifer storage or groundwater flows to surface features and are, therefore, not suitable as DFCs in those respects. Subsidence can result from artesian pressure declines in clay-rich layers; therefore, in areas where subsidence is a concern, selecting DFCs based on artesian pressure drawdown appears fitting. Water table levels can be used to monitor the amount of water in an aquifer and directly influence natural discharge to springs, seeps, streams, and other surface features. For these reasons, water table drawdowns also appear to be suitable as DFCs.

However, water table and artesian pressure declines do not represent good DFCs because they are not important in and of themselves; they must always be “translated” into information that speaks to the actual, desired management objectives. For example, when considering aquifer depletion, how much water table decline is acceptable? Obviously, the significance of the amount of water table drawdown can only be determined when compared and contrasted to other hydrologic information such as the structure, thickness, and permeability of an aquifer. If we want to manage groundwater availability, then a DFC explicitly stating the allowable changes in storage over time is more practical than attempting to manage depletion through drawdown limits.

Similarly, if it is decided that it is important to maintain flow from a certain spring, then the DFC should be based on a rate of springflow. While water table levels can influence groundwater discharge to springs, selection of a DFC based on water table drawdown only accomplishes the actual goal indirectly. Likewise, using artesian pressure drawdown to control subsidence is much less direct than simply choosing a DFC that expressly limits the allowable amount of subsidence. In addition to being more straightforward, direct limits are preferable because there are several factors other than water table and artesian pressure drawdown that affect springflow and subsidence.

Management of Impacts on Existing Users

Both water table levels and artesian pressures affect maximum well yields and the cost of producing groundwater. In general, maximum well production rates decline as regional artesian pressure or water table declines occur. Depending on the site-specific conditions, water table drawdown may reduce saturated thickness of updip portions of an aquifer to the point where it is no longer practical to produce groundwater. In addition to reduced well yields, pumping lift costs increase as wellbore pumping levels deepen.

Given these facts, water table and artesian pressure levels undoubtedly have the potential to affect the availability and economics of groundwater use, which suggests that regulating them is a necessary part of groundwater management. However, adopting drawdown as a DFC to limit potential impacts on existing users should be avoided because it sets the stage for unequal regulation. In order to understand why, it is helpful to consider the responsibilities of the landowners and the State with regard to the use and management of groundwater.

Groundwater is a common resource that is owned by every Texan who owns land over an aquifer. However, while a landowner may own the subsurface water, there is no assurance that the site-specific hydrologic conditions will allow him or her to produce as much as neighboring landowners. Consequently, it is not possible for the State to guarantee equal groundwater supplies for every landowner. Rather, it is the State’s responsibility to ensure that: 1)

groundwater resources are being beneficially used and managed and 2) that all stakeholders are allowed to try to produce their fair share. There should be no conflict between these two responsibilities; if it is decided that limiting groundwater use benefits the community, then those limits should be applied consistently to all stakeholders. If unequal restrictions are imposed, the landowner who is required to shoulder a heavier regulatory burden should be compensated for it.

Using DFCs as a way to limit impacts on existing users sets the stage for inequitable regulation because every user of groundwater from an aquifer contributes to artesian pressure and water table declines in that aquifer. Existing well owners have benefitted from a common resource and have drained water from neighboring landowners who have not used groundwater. In essence, DFCs designed to protect existing users elevate the rights of those who have profited from groundwater by limiting the rights of landowners who have conserved it.

Management of Regional Economic Impacts with Drawdown

But what about the effects that water table and artesian pressure levels have on the overall economy of a region? Won't too much drawdown reduce groundwater availability and negatively impact economic development? Yes, excessive declines have the potential to affect groundwater availability and the economic health of a region. However, it's important to realize that water table and artesian pressure levels are not the real issues in this instance; assuring that there is enough water for future needs is the true goal. DFCs defined specifically as acceptable amounts of available groundwater are much more appropriate than attempting to control availability by way of generic drawdown limits. It should also be noted that there are negative economic impacts associated with not using groundwater. In general, the increased electrical and well maintenance costs resulting from new pumpage are typically heavily outweighed by the economic benefits gained through development of additional groundwater supplies.

Alternative DFCs

As an alternative to current DFCs, an approach founded on changes in aquifer storage and the protection of unique hydrologic features or conditions is proposed. Two types of DFCs are recommended:

- 1) **Aquifer Storage DFC** – Adopt DFCs describing the acceptable amount of water in aquifer storage through time. An example could be: “We want at least 95% of the available water currently stored in the aquifer to still be available in 50 years.”
- 2) **“Spotlight” DFC** – Select conditions for specific areas or features that are uniquely affected by groundwater flows or effects. Examples of this kind of DFC could be: “The flow from Clearwater Spring shall be maintained at or above a minimum rate of ten cubic feet per second over the next 50 years,” or “The average land surface subsidence in Area 1 shall be limited to five feet over the next 50 years.”

DFCs defining acceptable declines in aquifer storage are not new; they have been in place in the Texas Panhandle for several years and have been shown to enjoy several advantages. DFCs based on regional aquifer storage allow for flexible water planning, while maintaining clear assurances that resource depletion is controlled. On a local level, managing aquifer storage makes sense because it can be verified easily and inexpensively through monitoring of water table

levels. In addition, changes in aquifer storage generally occur at a slow, steady pace that allows groundwater conservation districts to distinguish between important aquifer trends and localized, short-term fluctuations in artesian pressure. When definite, long-term trends can be recognized and discussed over time in a public forum, relations between regulators and stakeholders generally improve. Perhaps most importantly, managing groundwater in storage targets a primary concern of most Texans, succinctly and without uncertainty.

“Spotlight” DFCs that focus on managing special groundwater flows or effects can also be a helpful management tool for exceptional circumstances. In general, this type of DFC may be implemented where it is in the public interest to manage a specific hydrologic feature or condition, such as springflow or subsidence. A careful cost/benefit analysis should be completed before enacting a DFC targeted to achieve a specific public interest because of the greater potential for inflicting inconsistent regulatory burdens and subsequent property takings on landowners. However, while these types of DFCs may be more difficult to implement fairly, they can provide assurance that unique features or effects are properly managed.

Section 36.108(d) of the Texas Water Code lists several factors that must be considered (and reported) by GMA's during the selection of DFCs. Some of the most pertinent are:

- hydrological conditions, including for each aquifer in the management area the total estimated recoverable storage as provided by the executive administrator, and the average annual recharge, inflows, and discharge;
- other environmental impacts, including impacts on spring flow and other interactions between groundwater and surface water;
- the impact on subsidence;
- socioeconomic impacts reasonably expected to occur;
- the impact on the interests and rights in private property...

The proposed DFCs are advantageous because they allow for more straightforward assessments of these factors. Evaluation of the relationship between the DFCs and the “recoverable storage” and aquifer recharge/discharge flows is much simpler when the DFC specifically manages the volumes of groundwater in aquifer storage through time. Similarly, feature-specific “spotlight” DFCs (and the processes used to develop them) support relatively clear-cut discussions of environmental and economic impacts.

Concluding Thoughts

Section 36.108(d-2) of the Texas Water Code states that DFCs must provide a balance between:

...the highest practicable level of groundwater production and the conservation, preservation, protection, recharging, and prevention of waste of groundwater...

The existing DFCs make it more difficult for stakeholders to assess this balance because they are based on simulated drawdown, which does not directly speak to aquifer depletion, environmental concerns, or economic issues. The DFC/MAG process can be improved by shifting the focus

away from modeling results toward real-world aquifer measurements; groundwater models can be very useful tools for some tasks, but it is a mistake to integrate them so completely into the management process.

The alternative DFCs proposed herein are intended to improve the regulatory process by specifically managing the amount of groundwater in storage, as well as environmental flows or effects. By directly controlling these concerns, the proposed DFCs provide clear-cut assurances that groundwater resources are being properly managed. By concentrating on physical data and sensible goals, Texans can reshape the current regulatory system into something that promotes both responsible stewardship and use of our aquifers.

Appendix G

Socioeconomic Impacts Analyses for Regions K, L, and M



TEXAS WATER DEVELOPMENT BOARD



James E. Herring, *Chairman*
Lewis H. McMahan, *Member*
Edward G. Vaughan, *Member*

J. Kevin Ward
Executive Administrator

Jack Hunt, *Vice Chairman*
Thomas Weir Labatt III, *Member*
Joe M. Crutcher, *Member*

May 21, 2010

Mr. John Burke
Chairman, Lower Colorado Regional Water Planning Group
c/o Aqua Water Supply Corporation Manager
P.O. Drawer P
Bastrop, Texas 78602

Re: Socioeconomic Impact Analysis of Not Meeting Water Needs for the 2011 Lower Colorado Regional Water Plan

Dear Chairman Burke:

We have received your request for technical assistance to complete the socioeconomic impact analysis of not meeting water needs. In response, enclosed is a report that describes our methodology and presents the results. Section 1 provides an overview of the methodology, and Section 2 presents results for at the regional level, and Appendix 2 show results for individual water user groups.

If you have any questions or comments, please feel free to contact me at (512) 463-7928 or by email at stuart.norvell@twdb.state.tx.us.

Sincerely,

Stuart Norvell
Manager, Water Planning Research and Analysis
Water Resources Planning Division

SN/ao

Enclosure

c: David Meesey, TWDB
S. Doug Shaw, TWDB

Our Mission

To provide leadership, planning, financial assistance, information, and education for the conservation and responsible development of water for Texas.

P.O. Box 13231 • 1700 N. Congress Avenue • Austin, Texas 78711-3231
Telephone (512) 463-7847 • Fax (512) 475-2053 • 1-800-RELAYTX (for the hearing impaired)
www.twdb.state.tx.us • info@twdb.state.tx.us

TNRIS - Texas Natural Resources Information System • www.tnr.is.state.tx.us
A Member of the Texas Geographic Information Council (TGIC)



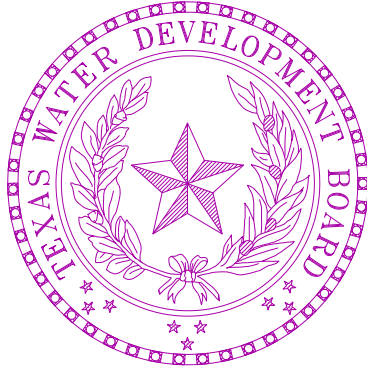

Socioeconomic Impacts of Projected Water Shortages for the Lower Colorado Regional Water Planning Area (Region K)

Prepared in Support of the 2011 Lower Colorado Regional Water Plan

Stuart D. Norvell, Managing Economist
Water Resources Planning Division
Texas Water Development Board
Austin, Texas

S. Doug Shaw, Agricultural Economist
Water Resources Planning Division
Texas Water Development Board
Austin, Texas

May 2010

Table of Contents

Section	Title	Page
	Introduction.....	3
1.0	Methodology.....	3
1.1	Economic Impacts of Water Shortages.....	3
1.1.1	General Approach.....	8
	General Assumptions and Clarifications of the Methodology.....	9
1.1.2	Impacts to Agriculture.....	9
	Irrigation.....	9
	Livestock.....	11
1.1.3	Impacts to Municipal Water User Groups.....	12
	Disaggregation of Municipal Water Demands.....	13
	Domestic Water Uses.....	14
	Commercial Businesses.....	17
	Water Utility Revenues.....	18
	Horticulture and Landscaping.....	18
	Recreational Impacts.....	19
1.1.4	Impacts to Industrial Water User Groups.....	19
	Manufacturing.....	20
	Mining.....	20
	Steam-electric.....	21
1.2	Social Impacts of Water Shortages.....	21
2.0	Results.....	22
2.1	Overview of Regional Economy.....	22
2.2	Impacts to Agricultural Water User Groups.....	23
2.3	Impacts to Municipal Water User Groups.....	24
2.4	Impacts to Manufacturing Water User Groups.....	24
2.5	Impacts to Mining Water User Groups.....	25
2.6	Impacts to Steam-electric Water User Groups.....	26
2.7	Social Impacts.....	26
2.8	Distribution of Impacts by Major River Basin.....	27
	Appendix 1: Economic Data for Individual IMPLAN Sectors.....	29
	Appendix 2: Impacts by County.....	33
Tables		
1	Crop Classifications and Corresponding IMPLAN Crop Sectors.....	10
2	Summary of Irrigated Crop Acreage and Water Demand.....	10
3	Average Gross Sales Revenues per Acre for Irrigated Crops.....	11
4	Description of Livestock Sectors.....	12
5	Water Use and Costs Parameters Used to Estimated Domestic Water Demand Functions.....	14
6	Economic Losses Associated with Domestic Water Shortages.....	16
7	Impacts of Municipal Water Shortages at Different Magnitudes of Shortages.....	19
8	Regional Baseline Economy by Water User Group.....	23
9	Economic Impacts of Water Shortages for Irrigation Water User Groups.....	23
10	Economic Impacts of Water Shortages for Municipal Water User Groups.....	24
11	Economic Impacts of Water Shortages for Manufacturing Water User Groups.....	25
12	Economic Impacts of Water Shortages for Mining Water User Groups.....	25
13	Economic Impacts of Water Shortages for Steam-electric Water User Groups.....	26
14	Social Impacts of Water Shortages.....	26
15	Distribution of Impacts by Major River Basin.....	27

Introduction

Water shortages during drought would likely curtail or eliminate economic activity in business and industries reliant on water. For example, without water farmers cannot irrigate; refineries cannot produce gasoline, and paper mills cannot make paper. Unreliable water supplies would not only have an immediate and real impact on existing businesses and industry, but they could also adversely affect economic development in Texas. From a social perspective, water supply reliability is critical as well. Shortages would disrupt activity in homes, schools and government and could adversely affect public health and safety. For all of the above reasons, it is important to analyze and understand how restricted water supplies during drought could affect communities throughout the state.

Administrative rules require that regional water planning groups evaluate the impacts of not meeting water needs as part of the regional water planning process, and rules direct TWDB staff to provide technical assistance: *“The executive administrator shall provide available technical assistance to the regional water planning groups, upon request, on water supply and demand analysis, including methods to evaluate the social and economic impacts of not meeting needs”* [(§357.7 (4)(A))]. Staff of the TWDB’s Water Resources Planning Division designed and conducted this report in support of the Lower Colorado Regional Water Planning Group (Region K).

This document summarizes the results of our analysis and discusses the methodology used to generate the results. Section 1 outlines the overall methodology and discusses approaches and assumptions specific to each water use category (i.e., irrigation, livestock, mining, steam-electric, municipal and manufacturing). Section 2 presents the results for each category where shortages are reported at the regional planning area level and river basin level. Results for individual water user groups are not presented, but are available upon request.

1. Methodology

Section 1 provides a general overview of how economic and social impacts were measured. In addition, it summarizes important clarifications, assumptions and limitations of the study.

1.1 Economic Impacts of Water Shortages

1.1.1 General Approach

Economic analysis as it relates to water resources planning generally falls into two broad areas. Supply side analysis focuses on costs and alternatives of developing new water supplies or implementing programs that provide additional water from current supplies. Demand side analysis concentrates on impacts or benefits of providing water to people, businesses and the environment. Analysis in this report focuses strictly on demand side impacts. When analyzing the economic impacts of water shortages as defined in Texas water planning, three potential scenarios are possible:

- 1) Scenario 1 involves situations where there are physical shortages of raw surface or groundwater due to drought of record conditions. For example, City A relies on a reservoir with average conservation storage of 500 acre-feet per year and a firm yield of 100 acre feet. In 2010, the city uses about 50 acre-feet per year, but by 2030 their demands are expected to increase to 200 acre-feet. Thus, in 2030 the reservoir would not have enough water to meet the city’s demands, and people would experience a shortage of 100 acre-feet assuming drought of record conditions.

Under normal or average climatic conditions, the reservoir would likely be able to provide reliable water supplies well beyond 2030.

- 2) Scenario 2 is a situation where despite drought of record conditions, water supply sources can meet existing use requirements; however, limitations in water infrastructure would preclude future water user groups from accessing these water supplies. For example, City B relies on a river that can provide 500 acre-feet per year during drought of record conditions and other constraints as dictated by planning assumptions. In 2010, the city is expected to use an estimated 100 acre-feet per year and by 2060 it would require no more than 400 acre-feet. But the intake and pipeline that currently transfers water from the river to the city's treatment plant has a capacity of only 200 acre-feet of water per year. Thus, the city's water supplies are adequate even under the most restrictive planning assumptions, but their conveyance system is too small. This implies that at some point – perhaps around 2030 - infrastructure limitations would constrain future population growth and any associated economic activity or impacts.
- 3) Scenario 3 involves water user groups that rely primarily on aquifers that are being depleted. In this scenario, projected and in some cases existing demands may be unsustainable as groundwater levels decline. Areas that rely on the Ogallala aquifer are a good example. In some communities in the region, irrigated agriculture forms a major base of the regional economy. With less irrigation water from the Ogallala, population and economic activity in the region could decline significantly assuming there are no offsetting developments.

Assessing the social and economic effects of each of the above scenarios requires various levels and methods of analysis and would generate substantially different results for a number of reasons; the most important of which has to do with the time frame of each scenario. Scenario 1 falls into the general category of static analysis. This means that models would measure impacts for a small interval of time such as a drought. Scenarios 2 and 3, on the other hand imply a dynamic analysis meaning that models are concerned with changes over a much longer time period.

Since administrative rules specify that planning analysis be evaluated under drought of record conditions (a static and random event), socioeconomic impact analysis developed by the TWDB for the state water plan is based on assumptions of Scenario 1. Estimated impacts under scenario 1 are point estimates for years in which needs are reported (2010, 2020, 2030, 2040, 2050 and 2060). They are independent and distinct “what if” scenarios for a particular year and shortages are assumed to be temporary events resulting from drought of record conditions. Estimated impacts measure what would happen if water user groups experience water shortages for a period of one year.

The TWDB recognize that dynamic models may be more appropriate for some water user groups; however, combining approaches on a statewide basis poses several problems. For one, it would require a complex array of analyses and models, and might require developing supply and demand forecasts under “normal” climatic conditions as opposed to drought of record conditions. Equally important is the notion that combining the approaches would produce inconsistent results across regions resulting in a so-called “apples to oranges” comparison.

A variety of tools are available to estimate economic impacts, but by far, the most widely used today are input-output models (IO models) combined with social accounting matrices (SAMs). Referred to as IO/SAM models, these tools formed the basis for estimating economic impacts for agriculture (irrigation and livestock water uses) and industry (manufacturing, mining, steam-electric and commercial business activity for municipal water uses).

Since the planning horizon extends through 2060, economic variables in the baseline are adjusted in accordance with projected changes in demographic and economic activity. Growth rates for municipal water use sectors (i.e., commercial, residential and institutional) are based on TWDB population forecasts. Future values for manufacturing, agriculture, and mining and steam-electric activity are based on the same underlying economic forecasts used to estimate future water use for each category.

The following steps outline the overall process.

Step 1: Generate IO/SAM Models and Develop Economic Baseline

IO/SAM models were estimated using propriety software known as IMPLAN PRO™ (Impact for Planning Analysis). IMPLAN is a modeling system originally developed by the U.S. Forestry Service in the late 1970s. Today, the Minnesota IMPLAN Group (MIG Inc.) owns the copyright and distributes data and software. It is probably the most widely used economic impact model in existence. IMPLAN comes with databases containing the most recently available economic data from a variety of sources.¹ Using IMPLAN software and data, transaction tables conceptually similar to the one discussed previously were estimated for each county in the region and for the region as a whole. Each transaction table contains 528 economic sectors and allows one to estimate a variety of economic statistics including:

- **total sales** - total production measured by sales revenues;
- **intermediate sales** - sales to other businesses and industries within a given region;
- **final sales** – sales to end users in a region and exports out of a region;
- **employment** - number of full and part-time jobs (annual average) required by a given industry including self-employment;
- **regional income** - total payroll costs (wages and salaries plus benefits) paid by industries, corporate income, rental income and interest payments; and
- **business taxes** - sales, excise, fees, licenses and other taxes paid during normal operation of an industry (does not include income taxes).

TWDB analysts developed an economic baseline containing each of the above variables using year 2000 data. Since the planning horizon extends through 2060, economic variables in the baseline were allowed to change in accordance with projected changes in demographic and economic activity. Growth rates for municipal water use sectors (i.e., commercial, residential and institutional) are based on TWDB population forecasts. Projections for manufacturing, agriculture, and mining and steam-electric activity are based on the same underlying economic forecasts used to estimate future water use for each category. Monetary impacts in future years are reported in constant year 2006 dollars.

It is important to stress that employment, income and business taxes are the most useful variables when comparing the relative contribution of an economic sector to a regional economy. Total sales as reported in IO/SAM models are less desirable and can be misleading because they include sales to other industries in the region for use in the production of other goods. For example, if a mill buys grain from local farmers and uses it to produce feed, sales of both the processed feed and raw corn are counted as “output” in an IO model. Thus, total sales double-count or overstate the true economic value of goods

¹The IMPLAN database consists of national level technology matrices based on benchmark input-output accounts generated by the U.S. Bureau of Economic Analysis and estimates of final demand, final payments, industry output and employment for various economic sectors. IMPLAN regional data (i.e. states, a counties or groups of counties within a state) are divided into two basic categories: 1) data on an industry basis including value-added, output and employment, and 2) data on a commodity basis including final demands and institutional sales. State-level data are balanced to national totals using a matrix ratio allocation system and county data are balanced to state totals.

and services produced in an economy. They are not consistent with commonly used measures of output such as Gross National Product (GNP), which counts only final sales.

Another important distinction relates to terminology. Throughout this report, the term *sector* refers to economic subdivisions used in the IMPLAN database and resultant input-output models (528 individual sectors based on Standard Industrial Classification Codes). In contrast, the phrase *water use category* refers to water user groups employed in state and regional water planning including irrigation, livestock, mining, municipal, manufacturing and steam electric. Each IMPLAN sector was assigned to a specific water use category.

Step 2: Estimate Direct and Indirect Economic Impacts of Water Needs

Direct impacts are reductions in output by sectors experiencing water shortages. For example, without adequate cooling and process water a refinery would have to curtail or cease operation, car washes may close, or farmers may not be able to irrigate and sales revenues fall. Indirect impacts involve changes in inter-industry transactions as supplying industries respond to decreased demands for their services, and how seemingly non-related businesses are affected by decreased incomes and spending due to direct impacts. For example, if a farmer ceases operations due to a lack of irrigation water, they would likely reduce expenditures on supplies such as fertilizer, labor and equipment, and businesses that provide these goods would suffer as well.

Direct impacts accrue to immediate businesses and industries that rely on water and without water industrial processes could suffer. However, output responses may vary depending upon the severity of shortages. A small shortage relative to total water use would likely have a minimal impact, but large shortages could be critical. For example, farmers facing small shortages might fallow marginally productive acreage to save water for more valuable crops. Livestock producers might employ emergency culling strategies, or they may consider hauling water by truck to fill stock tanks. In the case of manufacturing, a good example occurred in the summer of 1999 when Toyota Motor Manufacturing experienced water shortages at a facility near Georgetown, Kentucky.² As water levels in the Kentucky River fell to historic lows due to drought, plant managers sought ways to curtail water use such as reducing rinse operations to a bare minimum and recycling water by funneling it from paint shops to boilers. They even considered trucking in water at a cost of 10 times what they were paying. Fortunately, rains at the end of the summer restored river levels, and Toyota managed to implement cutbacks without affecting production, but it was a close call. If rains had not replenished the river, shortages could have severely reduced output.³

To account for uncertainty regarding the relative magnitude of impacts to farm and business operations, the following analysis employs the concept of elasticity. Elasticity is a number that shows how a change in one variable will affect another. In this case, it measures the relationship between a percentage reduction in water availability and a percentage reduction in output. For example, an elasticity of 1.0 indicates that a 1.0 percent reduction in water availability would result in a 1.0 percent reduction in economic output. An elasticity of 0.50 would indicate that for every 1.0 percent of unavailable water, output is reduced by 0.50 percent and so on. Output elasticities used in this study are:⁴

² Royal, W. "High And Dry - Industrial Centers Face Water Shortages." in Industry Week, Sept, 2000.

³ The efforts described above are not planned programmatic or long-term operational changes. They are emergency measures that individuals might pursue to alleviate what they consider a temporary condition. Thus, they are not characteristic of long-term management strategies designed to ensure more dependable water supplies such as capital investments in conservation technology or development of new water supplies.

⁴ Elasticities are based on one of the few empirical studies that analyze potential relationships between economic output and water shortages in the United States. The study, conducted in California, showed that a significant number of industries would suffer reduced output during water shortages. Using a survey based approach researchers posed two scenarios to different industries. In

- if water needs are 0 to 5 percent of total water demand, no corresponding reduction in output is assumed;
- if water needs are 5 to 30 percent of total water demand, for each additional one percent of water need that is not met, there is a corresponding 0.50 percent reduction in output;
- if water needs are 30 to 50 percent of total water demand, for each additional one percent of water need that is not met, there is a corresponding 0.75 percent reduction in output; and
- if water needs are greater than 50 percent of total water demand, for each additional one percent of water need that is not met, there is a corresponding 1.0 percent (i.e., a proportional reduction).

In some cases, elasticities are adjusted depending upon conditions specific to a given water user group.

Once output responses to water shortages were estimated, direct impacts to total sales, employment, regional income and business taxes were derived using regional level economic multipliers estimating using IO/SAM models. The formula for a given IMPLAN sector is:

$$D_{i,t} = Q_{i,t} * S_{i,t} * E_Q * RFD_i * DM_{i(Q,L,I,T)}$$

where:

$D_{i,t}$ = direct economic impact to sector i in period t

$Q_{i,t}$ = total sales for sector i in period t in an affected county

RFD_i = ratio of final demand to total sales for sector i for a given region

$S_{i,t}$ = water shortage as percentage of total water use in period t

E_Q = elasticity of output and water use

$DM_{i(L,I,T)}$ = direct output multiplier coefficients for labor (L), income (I) and taxes (T) for sector i .

Secondary impacts were derived using the same formula used to estimate direct impacts; however, indirect multiplier coefficients are used. Methods and assumptions specific to each water use sector are discussed in Sections 1.1.2 through 1.1.4.

the first scenario, they asked how a 15 percent cutback in water supply lasting one year would affect operations. In the second scenario, they asked how a 30 percent reduction lasting one year would affect plant operations. In the case of a 15 percent shortage, reported output elasticities ranged from 0.00 to 0.76 with an average value of 0.25. For a 30 percent shortage, elasticities ranged from 0.00 to 1.39 with average of 0.47. For further information, see, California Urban Water Agencies, "Cost of Industrial Water Shortages," Spectrum Economics, Inc. November, 1991.

General Assumptions and Clarification of the Methodology

As with any attempt to measure and quantify human activities at a societal level, assumptions are necessary and every model has limitations. Assumptions are needed to maintain a level of generality and simplicity such that models can be applied on several geographic levels and across different economic sectors. In terms of the general approach used here several clarifications and cautions are warranted:

1. Shortages as reported by regional planning groups are the starting point for socioeconomic analyses.
2. Estimated impacts are point estimates for years in which needs are reported (i.e., 2010, 2020, 2030, 2040, 2050 and 2060). They are independent and distinct “what if” scenarios for each particular year and water shortages are assumed to be temporary events resulting from severe drought conditions combined with infrastructure limitations. In other words, growth occurs and future shocks are imposed on an economy at 10-year intervals and resultant impacts are measured. Given that reported figures are not cumulative in nature, it is inappropriate to sum impacts over the entire planning horizon. Doing so, would imply that the analysis predicts that drought of record conditions will occur every ten years in the future, which is not the case. Similarly, authors of this report recognize that in many communities needs are driven by population growth, and in the future total population will exceed the amount of water available due to infrastructure limitations, regardless of whether or not there is a drought. This implies that infrastructure limitations would constrain economic growth. However, since needs as defined by planning rules are based upon water supply and demand under the assumption of drought of record conditions, it is improper to conduct economic analysis that focuses on growth related impacts over the planning horizon. Figures generated from such an analysis would presume a 50-year drought of record, which is unrealistic. Estimating lost economic activity related to constraints on population and commercial growth due to lack of water would require developing water supply and demand forecasts under “normal” or “most likely” future climatic conditions.
3. While useful for planning purposes, this study is not a benefit-cost analysis. Benefit cost analysis is a tool widely used to evaluate the economic feasibility of specific policies or projects as opposed to estimating economic impacts of unmet water needs. Nevertheless, one could include some impacts measured in this study as part of a benefit cost study if done so properly. Since this is not a benefit cost analysis, future impacts are not weighted differently. In other words, estimates are not discounted. If used as a measure of economic benefits, one should incorporate a measure of uncertainty into the analysis. In this type of analysis, a typical method of discounting future values is to assign probabilities of the drought of record recurring again in a given year, and weight monetary impacts accordingly. This analysis assumes a probability of one.
4. IO multipliers measure the strength of backward linkages to supporting industries (i.e., those who sell inputs to an affected sector). However, multipliers say nothing about forward linkages consisting of businesses that purchase goods from an affected sector for further processing. For example, ranchers in many areas sell most of their animals to local meat packers who process animals into a form that consumers ultimately see in grocery stores and restaurants. Multipliers do not capture forward linkages to meat packers, and since meat packers sell livestock purchased from ranchers as “final sales,” multipliers for the ranching sector do not fully account for all losses to a region’s economy. Thus, as mentioned previously, in some cases closely linked sectors were moved from one water use category to another.
5. Cautions regarding interpretations of direct and secondary impacts are warranted. IO/SAM multipliers are based on “fixed-proportion production functions,” which basically means that input use - including labor - moves in lockstep fashion with changes in levels of output. In a

scenario where output (i.e., sales) declines, losses in the immediate sector or supporting sectors could be much less than predicted by an IO/SAM model for several reasons. For one, businesses will likely expect to continue operating so they might maintain spending on inputs for future use; or they may be under contractual obligations to purchase inputs for an extended period regardless of external conditions. Also, employers may not lay-off workers given that experienced labor is sometimes scarce and skilled personnel may not be readily available when water shortages subside. Lastly people who lose jobs might find other employment in the region. As a result, direct losses for employment and secondary losses in sales and employment should be considered an upper bound. Similarly, since projected population losses are based on reduced employment in the region, they should be considered an upper bound as well.

6. IO models are static. Models and resultant multipliers are based upon the structure of the U.S. and regional economies in 2006. In contrast, water shortages are projected to occur well into the future. Thus, the analysis assumes that the general structure of the economy remains the same over the planning horizon, and the farther out into the future we go, this assumption becomes less reliable.
7. Impacts are annual estimates. If one were to assume that conditions persisted for more than one year, figures should be adjusted to reflect the extended duration. The drought of record in most regions of Texas lasted several years.
8. Monetary figures are reported in constant year 2006 dollars.

1.1.2 Impacts to Agriculture

Irrigated Crop Production

The first step in estimating impacts to irrigation required calculating gross sales for IMPLAN crop sectors. Default IMPLAN data do not distinguish irrigated production from dry-land production. Once gross sales were known other statistics such as employment and income were derived using IMPLAN direct multiplier coefficients. Gross sales for a given crop are based on two data sources:

- 1) county-level statistics collected and maintained by the TWDB and the USDA Farm Services Agency (FSA) including the number of irrigated acres by crop type and water application per acre, and
- 2) regional-level data published by the Texas Agricultural Statistics Service (TASS) including prices received for crops (marketing year averages), crop yields and crop acreages.

Crop categories used by the TWDB differ from those used in IMPLAN datasets. To maintain consistency, sales and other statistics are reported using IMPLAN crop classifications. Table 1 shows the TWDB crops included in corresponding IMPLAN sectors, and Table 2 summarizes acreage and estimated annual water use for each crop classification (five-year average from 2003-2007). As shown in Table 2, the overwhelming majority of irrigation in Region K is for rice. Table 3 displays average (2003-2007) gross revenues per acre for rice production applied in the analysis.

Table 1: Crop Classifications Used in TWDB Water Use Survey and Corresponding IMPLAN Crop Sectors

IMPLAN category	TWDB category
Oilseeds	Soybeans and "other oil crops"
Grains	Grain sorghum, corn, wheat and "other grain crops"
Vegetable and melons	"Vegetables" and potatoes
Tree nuts	Pecans
Fruits	Citrus, vineyard and other orchard
Cotton	Cotton
Sugarcane and sugar beets	Sugarcane and sugar beets
All "other" crops	"Forage crops", peanuts, alfalfa, hay and pasture, rice and "all other crops"

Table 2: Summary of Irrigated Crop Acreage and Water Demand for the Region K Regional Water Planning Area (average 2003-2007)

Sector	Acres (1000s)	Distribution of acres	Water use (1000s of AF)	Distribution of water use
Oilseeds	<1	<1%	<1	<1%
Grains	6.96	4%	9	2%
Vegetable and melons	<1	<1%	<1	<1%
Tree nuts	5	3%	7	1%
Fruits	<1	<1%	1.24	<1%
Cotton	1	1%	1.11	<1%
Rice	145	91%	541	97%
Total	160	100%	559.96	100%

Source: Water demand figures are a 5- year average (2003-2007) of the TWDB's annual Irrigation Water Use Estimates. Statistics for irrigated crop acreage are based upon annual survey data collected by the TWDB and the Farm Service Agency. Values do not include acreage or water use for the TWDB categories classified by the Farm Services Agency as "failed acres," "golf course" or "waste water."

Table 3: Average Gross Sales Revenues per Acre for Irrigated Crops for the Region K Regional Water Planning Area (2003-2007)		
IMPLAN Sector	Gross revenues per acre	Crops included in estimates
All Other Crops	\$460	Based on five-year (2003-2007) average weighted by acreage for "rice."
*Figures are rounded. Source: Based on data from the Texas Agricultural Statistics Service, Texas Water Development Board, and Texas A&M University.		

The following steps outline the overall process used to estimate direct impacts to irrigated agriculture:

1. *Distribute shortages across predominant crop types in the region.* Again, unmet water needs were distributed equally across crop sectors that constitute one percent or more of irrigated acreage.
2. *Estimate associated reductions in output for affected crop sectors.* Output reductions are based on elasticities discussed previously and on estimated values per acre for different crops. Values per acre stem from the same data used to estimate output for the year 2006 baseline. Using multipliers, we then generate estimates of forgone income, jobs, and tax revenues based on reductions in gross sales and final demand.
3. *Reduce sales revenues for forward processors in proportion to lost rice production.* As discussed in Section 1.1, input output models capture indirect losses to suppliers and other businesses that depend upon rice farming, but only those providing inputs to rice production. Multipliers do not capture potential impacts to forward processors, in this case rice mills, which add considerable value to the product and hence income and jobs to the state. For example, Texas rice farming directly generates about \$60 to \$80 in gross state product. Once the rice harvested it is sold to rice mills that process and resell the crop. This added value generates an additional \$60 to \$80 million in direct gross state product. Impacts measured in the study capture this additional value added.

Livestock

The approach used for the livestock sector is basically the same as that used for crop production. As is the case with crops, livestock categorizations used by the TWDB differ from those used in IMPLAN datasets, and TWDB groupings were assigned to a given IMPLAN sector (Table 4). Then we:

- 1) *Distribute projected water needs equally among predominant livestock sectors and estimate lost output:* As is the case with irrigation, shortages are assumed to affect all livestock sectors equally; however, the category of "other" is not included given its small size. If water needs were small relative to total demands, we assume that producers would haul in water by truck to fill

stock tanks. The cost per acre-foot (\$24,000) is based on 2008 rates charged by various water haulers in Texas, and assumes that the average truck load is 6,500 gallons at a hauling distance of 60 miles.

3) *Estimate reduced output in forward processors for livestock sectors.* Reductions in output for livestock sectors are assumed to have a proportional impact on forward processors in the region such as meat packers. In other words, if the cows were gone, meat-packing plants or fluid milk manufacturers) would likely have little to process. This is not an unreasonable premise. Since the 1950s, there has been a major trend towards specialized cattle feedlots, which in turn has decentralized cattle purchasing from livestock terminal markets to direct sales between producers and slaughterhouses. Today, the meat packing industry often operates large processing facilities near high concentrations of feedlots to increase capacity utilization.⁵ As a result, packers are heavily dependent upon nearby feedlots. For example, a recent study by the USDA shows that on average meat packers obtain 64 percent of cattle from within 75 miles of their plant, 82 percent from within 150 miles and 92 percent from within 250 miles.⁶

Table 4: Description of Livestock Sectors	
IMPLAN Category	TWDB Category
Cattle ranching	Cattle, cow calf, feedlots and dairies
Poultry and egg production	Poultry production.
Other livestock	Livestock other than cattle and poultry (i.e., horses, goats, sheep, hogs)
Milk manufacturing	Fluid milk manufacturing, cheese manufacturing, ice cream manufacturing etc.
Meat packing	Meat processing present in the region from slaughter to final processing

1.1.3 Impacts to Municipal Water User Groups

Disaggregation of Municipal Water Demands

Estimating the economic impacts for the municipal water user groups is complicated for a number of reasons. For one, municipal use comprises a range of consumers including commercial businesses, institutions such as schools and government and households. However, reported water needs are not distributed among different municipal water users. In other words, how much of a municipal need is commercial and how much is residential (domestic)?

The amount of commercial water use as a percentage of total municipal demand was estimated based on “GED” coefficients (gallons per employee per day) published in secondary sources.⁷ For example,

⁵ Ferreira, W.N. “*Analysis of the Meat Processing Industry in the United States.*” Clemson University Extension Economics Report ER211, January 2003.

⁶ Ward, C.E. “*Summary of Results from USDA’s Meatpacking Concentration Study.*” Oklahoma Cooperative Extension Service, OSU Extension Facts WF-562.

⁷ Sources for GED coefficients include: Gleick, P.H., Haasz, D., Henges-Jeck, C., Srinivasan, V., Wolff, G. Cushing, K.K., and Mann, A. “*Waste Not, Want Not: The Potential for Urban Water Conservation in California.*” Pacific Institute. November 2003. U.S. Bureau of

if year 2006 baseline data for a given economic sector (e.g., amusement and recreation services) shows employment at 30 jobs and the GED coefficient is 200, then average daily water use by that sector is (30 x 200 = 6,000 gallons) or 6.7 acre-feet per year. Water not attributed to commercial use is considered domestic, which includes single and multi-family residential consumption, institutional uses and all use designated as "county-other." Based on our analysis, commercial water use is about 5 to 35 percent of municipal demand. Less populated rural counties occupy the lower end of the spectrum, while larger metropolitan counties are at the higher end.

After determining the distribution of domestic versus commercial water use, we developed methods for estimating impacts to the two groups.

Domestic Water Uses

Input output models are not well suited for measuring impacts of shortages for domestic water uses, which make up the majority of the municipal water use category. To estimate impacts associated with domestic water uses, municipal water demand and needs are subdivided into residential, and commercial and institutional use. Shortages associated with residential water uses are valued by estimating proxy demand functions for different water user groups allowing us to estimate the marginal value of water, which would vary depending upon the level of water shortages. The more severe the water shortage, the more costly it becomes. For instance, a 2 acre-foot shortage for a group of households that use 10 acre-feet per year would not be as severe as a shortage that amounted to 8 acre-feet. In the case of a 2 acre-foot shortage, households would probably have to eliminate some or all outdoor water use, which could have implicit and explicit economic costs including losses to the horticultural and landscaping industry. In the case of an 8 acre-foot shortage, people would have to forgo all outdoor water use and most indoor water consumption. Economic impacts would be much higher in the latter case because people, and would be forced to find emergency alternatives assuming alternatives were available.

To estimate the value of domestic water uses, TWDB staff developed marginal loss functions based on constant elasticity demand curves. This is a standard and well-established method used by economists to value resources such as water that have an explicit monetary cost.

A constant price elasticity of demand is estimated using a standard equation:

$$w = kc^{(-\epsilon)}$$

where:

- w is equal to average monthly residential water use for a given water user group measured in thousands of gallons;
- k is a constant intercept;
- c is the average cost of water per 1,000 gallons; and
- ϵ is the price elasticity of demand.

the Census. 1982 Census of Manufacturers: Water Use in Manufacturing. USGPO, Washington D.C. See also: "U.S. Army Engineer Institute for Water Resources, IWR Report 88-R-6.," Fort Belvoir, VA. See also, Joseph, E. S., 1982, "Municipal and Industrial Water Demands of the Western United States." Journal of the Water Resources Planning and Management Division, Proceedings of the American Society of Civil Engineers, v. 108, no. WR2, p. 204-216. See also, Baumann, D. D., Boland, J. J., and Sims, J. H., 1981, "Evaluation of Water Conservation for Municipal and Industrial Water Supply." U.S. Army Corps of Engineers, Institute for Water Resources, Contract no. 82-C1.

Price elasticities (-0.30 for indoor water use and -0.50 for outdoor use) are based on a study by Bell et al.⁸ that surveyed 1,400 water utilities in Texas that serve at least 1,000 people to estimate demand elasticity for several variables including price, income, weather etc. Costs of water and average use per month per household are based on data from the Texas Municipal League's annual water and wastewater rate surveys - specifically average monthly household expenditures on water and wastewater in different communities across the state. After examining variance in costs and usage, three different categories of water user groups based on population (population less than 5,000, cities with populations ranging from 5,000 to 99,999 and cities with populations exceeding 100,000) were selected to serve as proxy values for municipal water groups that meet the criteria (Table 5).⁹

Table 5: Water Use and Costs Parameters Used to Estimated Water Demand Functions (average monthly costs per acre-foot for delivered water and average monthly use per household)				
Community Population	Water	Wastewater	Total Monthly Cost	Avg. Monthly Use (gallons)
Less than or equal to 5,000	\$1,335	\$1,228	\$2,563	6,204
5,000 to 100,000	\$1,047	\$1,162	\$2,209	7,950
Great than or equal to 100,000	\$718	\$457	\$1,190	8,409
Source: Based on annual water and wastewater rate surveys published by the Texas Municipal League.				

As an example, Table 6 shows the economic impact per acre-foot of domestic water needs for municipal water user groups with population exceeding 100,000 people. There are several important assumptions incorporated in the calculations:

- 1) Reported values are net of the variable costs of treatment and distribution such as expenses for chemicals and electricity since using less water involves some savings to consumers and utilities alike; and for outdoor uses we do not include any value for wastewater.
- 2) Outdoor and “non-essential” water uses would be eliminated before indoor water consumption was affected, which is logical because most water utilities in Texas have drought contingency plans that generally specify curtailment or elimination of outdoor water use during droughts.¹⁰ Determining how much water is used for outdoor purposes is based on several secondary sources. The first is a major study sponsored by the

⁸ Bell, D.R. and Griffin, R.C. “Community Water Demand in Texas as a Century is Turned.” Research contract report prepared for the Texas Water Development Board. May 2006.

⁹ Ideally, one would want to estimate demand functions for each individual utility in the state. However, this would require an enormous amount of time and resources. For planning purposes, we believe the values generated from aggregate data are more than sufficient.

¹⁰ In Texas, state law requires retail and wholesale water providers to prepare and submit plans to the Texas Commission on Environmental Quality (TCEQ). Plans must specify demand management measures for use during drought including curtailment of “non-essential water uses.” Non-essential uses include, but are not limited to, landscape irrigation and water for swimming pools or fountains. For further information see the Texas Environmental Quality Code §288.20.

American Water Works Association, which surveyed cities in states including Colorado, Oregon, Washington, California, Florida and Arizona. On average across all cities surveyed 58 percent of single family residential water use was for outdoor activities. In cities with climates comparable to large metropolitan areas of Texas, the average was 40 percent.¹¹ Earlier findings of the U.S. Water Resources Council showed a national average of 33 percent. Similarly, the United States Environmental Protection Agency (USEPA) estimated that landscape watering accounts for 32 percent of total residential and commercial water use on annual basis.¹² A study conducted for the California Urban Water Agencies (CUWA) calculated average annual values ranging from 25 to 35 percent.¹³ Unfortunately, there does not appear to be any comprehensive research that has estimated non-agricultural outdoor water use in Texas. As an approximation, an average annual value of 30 percent based on the above references was selected to serve as a rough estimate in this study.

3) As shortages approach 100 percent values become immense and theoretically infinite at 100 percent because at that point death would result, and willingness to pay for water is immeasurable. Thus, as shortages approach 80 percent of monthly consumption, we assume that households and non-water intensive commercial businesses (those that use water only for drinking and sanitation would have water delivered by tanker truck or commercial water delivery companies. Based on reports from water companies throughout the state, we estimate that the cost of trucking in water is around \$21,000 to \$27,000 per acre-feet assuming a hauling distance of between 20 to 60 miles. This is not an unreasonable assumption. The practice was widespread during the 1950s drought and recently during droughts in this decade. For example, in 2000 at the heels of three consecutive drought years Electra - a small town in North Texas - was down to its last 45 days worth of reservoir water when rain replenished the lake, and the city was able to refurbish old wells to provide supplemental groundwater. At the time, residents were forced to limit water use to 1,000 gallons per person per month - less than half of what most people use - and many were having water delivered to their homes by private contractors.¹⁴ In 2003 citizens of Ballinger, Texas, were also faced with a dwindling water supply due to prolonged drought. After three years of drought, Lake Ballinger, which supplies water to more than 4,300 residents in Ballinger and to 600 residents in nearby Rowena, was almost dry. Each day, people lined up to get water from a well in nearby City Park. Trucks hauling trailers outfitted with large plastic and metal tanks hauled water to and from City Park to Ballinger.¹⁵

¹¹ See, Mayer, P.W., DeOreo, W.B., Opitz, E.M., Kiefer, J.C., Davis, W., Dziegielewski, D., Nelson, J.O. "Residential End Uses of Water." Research sponsored by the American Water Works Association and completed by Aquacraft, Inc. and Planning and Management Consultants, Ltd. (PMCL@CDM).

¹² U.S. Environmental Protection Agency. "Cleaner Water through Conservation." USEPA Report no. 841-B-95-002. April, 1995.

¹³ Planning and Management Consultants, Ltd. "Evaluating Urban Water Conservation Programs: A Procedures Manual." Prepared for the California Urban Water Agencies. February 1992.

¹⁴ Zewe, C. "Tap Threatens to Run Dry in Texas Town." July 11, 2000. CNN Cable News Network.

¹⁵ Associated Press, "Ballinger Scrambles to Finish Pipeline before Lake Dries Up." May 19, 2003.

Table 6: Economic Losses Associated with Domestic Water Shortages in Communities with Populations Exceeding 100,000 people

Water shortages as a percentage of total monthly household demands	No. of gallons remaining per household per day	No of gallons remaining per person per day	Economic loss (per acre-foot)		Economic loss (per gallon)	
1%	278	93	\$748		\$0.00005	
5%	266	89	\$812		\$0.0002	
10%	252	84	\$900		\$0.0005	
15%	238	79	\$999		\$0.0008	
20%	224	75	\$1,110		\$0.0012	
25%	210	70	\$1,235		\$0.0015	
30% ^a	196	65	\$1,699		\$0.0020	
35%	182	61	\$3,825		\$0.0085	
40%	168	56	\$4,181		\$0.0096	
45%	154	51	\$4,603		\$0.011	
50%	140	47	\$5,109		\$0.012	
55%	126	42	\$5,727		\$0.014	
60%	112	37	\$6,500		\$0.017	
65%	98	33	\$7,493		\$0.02	
70%	84	28	\$8,818		\$0.02	
75%	70	23	\$10,672		\$0.03	
80%	56	19	\$13,454		\$0.04	
85%	42	14	\$18,091	(\$24,000) ^b	\$0.05	(\$0.07) ^b
90%	28	9	\$27,363	(\$24,000)	\$0.08	(\$0.07)
95%	14	5	\$55,182	(\$24,000)	\$0.17	(\$0.07)
99%	3	0.9	\$277,728	(\$24,000)	\$0.85	(\$0.07)
99.9%	1	0.5	\$2,781,377	(\$24,000)	\$8.53	(\$0.07)
100%	0	0	Infinite	(\$24,000)	Infinite	(\$0.07)

^a The first 30 percent of needs are assumed to be restrictions of outdoor water use; when needs reach 30 percent of total demands all outdoor water uses would be restricted. Needs greater than 30 percent include indoor use.

^b As shortages approach 100 percent the value approaches infinity assuming there are not alternatives available; however, we assume that communities would begin to have water delivered by tanker truck at an estimated cost of \$24,000 per acre-foot when shortages breached 85 percent.

Commercial Businesses

Effects of water shortages on commercial sectors were estimated in a fashion similar to other business sectors meaning that water shortages would affect the ability of these businesses to operate. This is particularly true for “water intensive” commercial sectors that are need large amounts of water (in addition to potable and sanitary water) to provide their services. These include:

- car-washes,
- laundry and cleaning facilities,
- sports and recreation clubs and facilities including race tracks,
- amusement and recreation services,
- hospitals and medical facilities,
- hotels and lodging places, and
- eating and drinking establishments.

A key assumption is that commercial operations would not be affected until water shortages were at least 50 percent of total municipal demand. In other words, we assume that residential water consumers would reduce water use including all non-essential uses before businesses were affected.

An example will illustrate the breakdown of municipal water needs and the overall approach to estimating impacts of municipal needs. Assume City A experiences an unexpected shortage of 50 acre-feet per year when their demands are 200 acre-feet per year. Thus, shortages are only 25 percent of total municipal use and residents of City A could eliminate needs by restricting landscape irrigation. City B, on the other hand, has a deficit of 150 acre-feet in 2020 and a projected demand of 200 acre-feet. Thus, total shortages are 75 percent of total demand. Emergency outdoor and some indoor conservation measures could eliminate 50 acre-feet of projected needs, yet 50 acre-feet would still remain. To eliminate” the remaining 50 acre-feet water intensive commercial businesses would have to curtail operations or shut down completely.

Three other areas were considered when analyzing municipal water shortages: 1) lost revenues to water utilities, 2) losses to the horticultural and landscaping industries stemming for reduction in water available for landscape irrigation, and 3) lost revenues and related economic impacts associated with reduced water related recreation.

Water Utility Revenues

Estimating lost water utility revenues was straightforward. We relied on annual data from the “*Water and Wastewater Rate Survey*” published annually by the Texas Municipal League to calculate an average value per acre-foot for water and sewer. For water revenues, average retail water and sewer rates multiplied by total water needs served as a proxy. For lost wastewater, total unmet needs were adjusted for return flow factor of 0.60 and multiplied by average sewer rates for the region. Needs reported as “county-other” were excluded under the presumption that these consist primarily of self-supplied water uses. In addition, 15 percent of water demand and needs are considered non-billed or “unaccountable” water that comprises things such as leakages and water for municipal government functions (e.g., fire departments). Lost tax receipts are based on current rates for the “miscellaneous gross receipts tax,” which the state collects from utilities located in most incorporated cities or towns in Texas. We do not include lost water utility revenues when aggregating impacts of municipal water shortages to regional and state levels to prevent double counting.

Horticultural and Landscaping Industry

The horticultural and landscaping industry, also referred to as the “green Industry,” consists of businesses that produce, distribute and provide services associated with ornamental plants, landscape and garden supplies and equipment. Horticultural industries often face big losses during drought. For example, the recent drought in the Southeast affecting the Carolinas and Georgia horticultural and landscaping businesses had a harsh year. Plant sales were down, plant mortality increased, and watering costs increased. Many businesses were forced to close locations, lay off employees, and even file for bankruptcy. University of Georgia economists put statewide losses for the industry at around \$3.2 billion during the 3-year drought that ended in 2008.¹⁶ Municipal restrictions on outdoor watering play a significant role. During drought, water restrictions coupled with persistent heat has a psychological effect on homeowners that reduces demands for landscaping products and services. Simply put, people were afraid to spend any money on new plants and landscaping.

In Texas, there do not appear to be readily available studies that analyze the economic effects of water shortages on the industry. However, authors of this report believe negative impacts do and would result in restricting landscape irrigation to municipal water consumers. The difficulty in measuring them is two-fold. First, as noted above, data and research for these types of impacts that focus on Texas are limited; and second, economic data provided by IMPLAN do not disaggregate different sectors of the green industry to a level that would allow for meaningful and defensible analysis.¹⁷

Recreational Impacts

Recreational businesses often suffer when water levels and flows in rivers, springs and reservoirs fall significantly during drought. During droughts, many boat docks and lake beaches are forced to close, leading to big losses for lakeside business owners and local communities. Communities adjacent to popular river and stream destinations such as Comal Springs and the Guadalupe River also see their business plummet when springs and rivers dry up. Although there are many examples of businesses that have suffered due to drought, dollar figures for drought-related losses to the recreation and tourism industry are not readily available, and very difficult to measure without extensive local surveys. Thus, while they are important, economic impacts are not measured in this study.

Table 7 summarizes impacts of municipal water shortages at differing levels of magnitude, and shows the ranges of economic costs or losses per acre-foot of shortage for each level.

¹⁶ Williams, D. “Georgia landscapers eye rebound from Southeast drought.” Atlanta Business Chronicle, Friday, June 19, 2009

¹⁷ Economic impact analyses prepared by the TWDB for 2006 regional water plans did include estimates for the horticultural industry. However, year 2000 and prior IMPLAN data were disaggregated to a finer level. In the current dataset (2006), the sector previously listed as “Landscaping and Horticultural Services” (IMPLAN Sector 27) is aggregated into “Services to Buildings and Dwellings” (IMPLAN Sector 458).

Table 7: Impacts of Municipal Water Shortages at Different Magnitudes of Shortages		
Water shortages as percent of total municipal demands	Impacts	Economic costs per acre-foot*
0-30%	<ul style="list-style-type: none"> ✓ Lost water utility revenues ✓ Restricted landscape irrigation and non-essential water uses 	\$730 - \$2,040
30-50%	<ul style="list-style-type: none"> ✓ Lost water utility revenues ✓ Elimination of landscape irrigation and non-essential water uses ✓ Rationing of indoor use 	\$2,040 - \$10,970
>50%	<ul style="list-style-type: none"> ✓ Lost water utility revenues ✓ Elimination of landscape irrigation and non-essential water uses ✓ Rationing of indoor use ✓ Restriction or elimination of commercial water use ✓ Importing water by tanker truck 	\$10,970 - varies
*Figures are rounded		

1.1.4 Industrial Water User Groups

Manufacturing

Impacts to manufacturing were estimated by distributing water shortages among industrial sectors at the county level. For example, if a planning group estimates that during a drought of record water supplies in County A would only meet 50 percent of total annual demands for manufactures in the county, we reduced output for each sector by 50 percent. Since projected manufacturing demands are based on TWDB Water Uses Survey data for each county, we only include IMPLAN sectors represented in the TWDB survey database. Some sectors in IMPLAN databases are not part of the TWDB database given that they use relatively small amounts of water - primarily for on-site sanitation and potable purposes. To maintain consistency between IMPLAN and TWDB databases, Standard Industrial Classification (SIC) codes both databases were cross referenced in county with shortages. Non-matches were excluded when calculating direct impacts.

Mining

The process of mining is very similar to that of manufacturing. We assume that within a given county, shortages would apply equally to relevant mining sectors, and IMPLAN sectors are cross referenced with TWDB data to ensure consistency.

In Texas, oil and gas extraction and sand and gravel (aggregates) operations are the primary mining industries that rely on large volumes of water. For sand and gravel, estimated output reductions are straightforward; however, oil and gas is more complicated for a number of reasons. IMPLAN does not necessarily report the physical extraction of minerals by geographic local, but rather the sales revenues reported by a particular corporation.

For example, at the state level revenues for IMPLAN sector 19 (oil and gas extraction) and sector 27 (drilling oil and gas wells) totals \$257 billion. Of this, nearly \$85 billion is attributed to Harris County. However, only a very small fraction (less than one percent) of actual production takes place in the county. To measure actual potential losses in well head capacity due to water shortages, we relied on county level production data from the Texas Railroad Commission (TRC) and average well-head market prices for crude and gas to estimate lost revenues in a given county. After which, we used to IMPLAN ratios to estimate resultant losses in income and employment.

Other considerations with respect to mining include:

- 1) Petroleum and gas extraction industry only uses water in significant amounts for secondary recovery. Known in the industry as enhanced or water flood extraction, secondary recovery involves pumping water down injection wells to increase underground pressure thereby pushing oil or gas into other wells. IMPLAN output numbers do not distinguish between secondary and non-secondary recovery. To account for the discrepancy, county-level TRC data that show the proportion of barrels produced using secondary methods were used to adjust IMPLAN data to reflect only the portion of sales attributed to secondary recovery.
- 2) A substantial portion of output from mining operations goes directly to businesses that are classified as manufacturing in our schema. Thus, multipliers measuring backward linkages for a given manufacturer might include impacts to a supplying mining operation. Care was taken not to double count in such situations if both a mining operation and a manufacturer were reported as having water shortages.

Steam-electric

At minimum without adequate cooling water, power plants cannot safely operate. As water availability falls below projected demands, water levels in lakes and rivers that provide cooling water would also decline. Low water levels could affect raw water intakes and outfalls at electrical generating units in several ways. For one, power plants are regulated by thermal emission guidelines that specify the maximum amount of heat that can go back into a river or lake via discharged cooling water. Low water levels could result in permit compliance issues due to reduced dilution and dispersion of heat and subsequent impacts on aquatic biota near outfalls.¹⁸ However, the primary concern would be a loss of head (i.e., pressure) over intake structures that would decrease flows through intake tunnels. This would affect safety related pumps, increase operating costs and/or result in sustained shut-downs. Assuming plants did shutdown, they would not be able to generate electricity.

¹⁸ Section 316 (b) of the Clean Water Act requires that thermal wastewater discharges do not harm fish and other wildlife.

Among all water use categories steam-electric is unique and cautions are needed when applying methods used in this study. Measured changes to an economy using input-output models stem directly from changes in sales revenues. In the case of water shortages, one assumes that businesses will suffer lost output if process water is in short supply. For power generation facilities this is true as well. However, the electric services sector in IMPLAN represents a corporate entity that may own and operate several electrical generating units in a given region. If one unit became inoperable due to water shortages, plants in other areas or generation facilities that do not rely heavily on water such as gas powered turbines might be able to compensate for lost generating capacity. Utilities could also offset lost production via purchases on the spot market.¹⁹ Thus, depending upon the severity of the shortages and conditions at a given electrical generating unit, energy supplies for local and regional communities could be maintained. But in general, without enough cooling water, utilities would have to throttle back plant operations, forcing them to buy or generate more costly power to meet customer demands.

Measuring impacts end users of electricity is not part of this study as it would require extensive local and regional level analysis of energy production and demand. To maintain consistency with other water user groups, impacts of steam-electric water shortages are measured in terms of lost revenues (and hence income) and jobs associated with shutting down electrical generating units.

1.2 Social Impacts of Water Shortages

As the name implies, the effects of water shortages can be social or economic. Distinctions between the two are both semantic and analytical in nature – more so analytic in the sense that social impacts are harder to quantify. Nevertheless, social effects associated with drought and water shortages are closely tied to economic impacts. For example, they might include:

- demographic effects such as changes in population,
- disruptions in institutional settings including activity in schools and government,
- conflicts between water users such as farmers and urban consumers,
- health-related low-flow problems (e.g., cross-connection contamination, diminished sewage flows, increased pollutant concentrations),
- mental and physical stress (e.g., anxiety, depression, domestic violence),
- public safety issues from forest and range fires and reduced fire fighting capability,
- increased disease caused by wildlife concentrations,
- loss of aesthetic and property values, and
- reduced recreational opportunities.²⁰

¹⁹ Today, most utilities participate in large interstate “power pools” and can buy or sell electricity “on the grid” from other utilities or power marketers. Thus, assuming power was available to buy, and assuming that no contractual or physical limitations were in place such as transmission constraints; utilities could offset lost power that resulted from waters shortages with purchases via the power grid.

²⁰ Based on information from the website of the National Drought Mitigation Center at the University of Nebraska Lincoln. Available online at: <http://www.drought.unl.edu/risk/impacts.htm>. See also, Vanclay, F. “*Social Impact Assessment.*” in Petts, J. (ed) *International Handbook of Environmental Impact Assessment.* 1999.

Social impacts measured in this study focus strictly on demographic effects including changes in population and school enrollment. Methods are based on demographic projection models developed by the Texas State Data Center and used by the TWDB for state and regional water planning. Basically, the social impact model uses results from the economic component of the study and assesses how changes in labor demand would affect migration patterns in a region. Declines in labor demand as measured using adjusted IMPLAN data are assumed to affect net economic migration in a given regional water planning area. Employment losses are adjusted to reflect the notion that some people would not relocate but would seek employment in the region and/or public assistance and wait for conditions to improve. Changes in school enrollment are simply the proportion of lost population between the ages of 5 and 17.

2. Results

Section 2 presents the results of the analysis at the regional level. Included are baseline economic data for each water use category, and estimated economics impacts of water shortages for water user groups with reported deficits. According to the 2011 *Lower Colorado Regional Water Plan*, during severe drought irrigation, municipal, manufacturing, mining and steam-electric water user groups would experience water shortages in the absence of new water management strategies.

2.1 Overview of Regional Economy

On an annual basis, the Region K economy generates slightly more than \$79 billion in gross state product for Texas (\$73 billion in income and \$6 billion in state and local business taxes) and supports nearly 1,033,690 jobs (Table 8). Generating nearly \$12 billion worth of income per year manufacturing (particularly computer electronics and pharmaceuticals) is the primary base economic sector in the region.²¹ Municipal sectors also generate substantial amounts of activity, nearly \$61 billion per year in gross state product, and are major employers in the region. While municipal sectors are the largest employer and source of wealth, many businesses that make up the municipal category such as restaurants and retail stores are non-basic industries meaning they exist to provide services to people who work would in base industries such as manufacturing. In other words, without base industries many municipal jobs would not exist.

²¹ Base industries are those that supply markets outside of a region. These industries are crucial to the local economy and are called the economic base of a region. Appendix A shows how IMPLAN's 529 sectors were allocated to water use category, and shows economic data for each sector.

Table 8: The Lower Colorado Regional Economy by Water User Group (\$millions) ^a						
Water Use Category	Total sales	Intermediate sales	Final sales	Jobs	Income	Business taxes
Irrigation ^b	\$132.09	\$67.62	\$64.64	1,905	\$62.55	\$2.41
Livestock	\$992.27	\$549.93	\$442.34	13,264	\$99.62	\$13.36
Manufacturing	\$56,646.30	\$14,932.96	\$41,713.34	127,416	\$12,275.86	\$348.07
Mining	\$2,578.62	\$1,837.98	\$740.64	\$4,439.00	\$1,572.37	\$137.52
Steam-electric	\$1,342.07	\$377.55	\$964.52	2,823	\$932.02	\$158.93
Municipal	\$96,908.91	\$31,257.19	\$65,651.72	883,845	\$57,858.80	\$5,225.90
Regional total	\$158,600.26	\$49,023.23	\$109,577.20	1,033,692	\$72,801.22	\$5,886.19

^a Appendix 1 displays data for individual IMPLAN sectors that make up each water use category.
^b Irrigation includes activity for both rice farms and rice mills.
Source: Based on data from the Texas Water Development Board, and year 2006 data from the Minnesota IMPLAN Group, Inc.

2.2 Impacts of Agricultural Water Shortages

Irrigation

According to the 2011 *Lower Colorado Regional Water Plan*, during severe drought the counties of Bastrop, Colorado, Fayette, Matagorda, Mills and Wharton would experience shortages of irrigation water without new management strategies. Shortages of these magnitudes would reduce gross state product (income plus state and local business taxes) by an estimated \$84 million in 2010 and \$56 million in 2060 with potential job losses ranging from 994 to 660 (Table 9). Figures include impacts to rice mills.

Table 9: Economic Impacts of Water Shortages for Irrigation Water User Groups (\$millions)			
Decade	Lost income from reduced rice production and milling activity *	Lost state and local tax revenues from reduced rice production and milling activity	Lost jobs from rice production and milling activity
2010	\$75.35	\$8.72	994
2020	\$70.93	\$8.21	935
2030	\$66.12	\$7.65	872
2040	\$61.50	\$7.12	811
2050	\$57.05	\$6.60	752
2060	\$50.09	\$5.80	660

*Changes to Income and business taxes are collectively equivalent to a decrease in gross state product, which is analogous to gross domestic product measured at the state rather than national level. Appendix 2 shows results by water user group.

Livestock

Several counties (Colorado, Fayette, Llano, and Matagorda) show water shortages for livestock producers. Given that these shortages are small relative to total livestock demands, we assume producers would haul water by tanker to fill stock pond and cisterns. The cost to producers across all counties would total about \$4.5 million per annum in each decade.

2.3 Impacts of Municipal Water Shortages

Water shortages are projected to occur in a significant number of communities in Region K. At the regional level, the estimated economic value of domestic water shortages totals \$63 million in 2010 and \$1,034 million in 2060 (Table 10). Municipal shortages would also restrict the operation of many commercial businesses reducing gross state product by an estimated \$43 million in 2010 and \$633 million in 2060.

Decade	Monetary value of domestic water shortages	Lost income from reduced commercial business activity*	Lost state and local taxes from reduced commercial business activity	Lost jobs from reduced commercial business activity	Lost water utility revenues
2010	\$63.32	\$38.33	\$3.97	733	\$13.24
2020	\$277.85	\$182.18	\$18.26	3,528	\$37.05
2030	\$385.04	\$245.98	\$24.88	4,861	\$55.64
2040	\$529.21	\$339.71	\$35.32	7,042	\$83.14
2050	\$756.51	\$396.14	\$41.36	8,282	\$153.95
2060	\$1,034.28	\$573.34	\$60.28	12,222	\$230.90

*Changes to Income and business taxes are collectively equivalent to a decrease in gross state product, which is analogous to gross domestic product measured at the state rather than national level. Appendix 2 shows results by water user group.

2.4 Impacts of Manufacturing Water Shortages

Manufacturing water shortages are projected to occur in Bastrop, Fayette, Hays, Matagorda and Wharton counties. The Region K planning group estimates that these manufacturers would be short nearly 150 acre-feet of water in 2010 and about 935 acre-feet in 2060. Shortages of these magnitudes would reduce gross state product (income plus taxes) by an estimated \$5 million in 2010 and \$65 million in 2060 (Table 11).

Table 11: Economic Impacts of Water Shortages for Manufacturing Water User Groups (\$millions)			
Decade	Lost income due to reduced manufacturing output	Lost state and local business tax revenues due to reduced manufacturing output	Lost jobs due to reduced manufacturing output
2010	\$4.64	\$0.45	97
2020	\$13.09	\$1.31	285
2030	\$22.11	\$2.05	431
2040	\$28.59	\$2.62	549
2050	\$34.26	\$3.12	651
2060	\$59.48	\$4.95	987
*Changes to Income and business taxes are collectively equivalent to a decrease in gross state product, which is analogous to gross domestic product measured at the state rather than national level. Appendix 2 shows results by water user group.			

2.5 Impacts of Mining Water Shortages

Mining water shortages are projected to occur in Burnett, Fayette, and Liberty counties, and would primarily affect aggregates (sand and gravel) operations. In total, shortages would reduce gross state product by an estimated \$19 million in 2010 and \$12 million in 2060 (Table 12).

Table 12: Economic Impacts of Water Shortages for Mining Water User Groups (\$millions)			
Decade	Lost income due to reduced mining output	Lost state and local business tax revenues due to reduced mining output	Lost jobs due to reduced mining output
2010	\$17.57	\$1.19	159
2020	\$16.82	\$1.14	153
2030	\$15.40	\$1.04	140
2040	\$13.36	\$0.90	122
2050	\$10.74	\$0.71	98
2060	\$11.16	\$0.74	102
*Changes to Income and business taxes are collectively equivalent to a decrease in gross state product, which is analogous to gross domestic product measured at the state rather than national level. Appendix 2 shows results by water user group.			

2.6 Impacts of Steam-electric Water Shortages

Water shortages for steam-electric water user groups are projected to occur in Bastrop, Fayette, Matagorda, Travis, and Wharton counties, and would reduce gross state product by \$2 million dollars in 2010, and \$2,559 million 2060 (Table 13).

Table 13: Economic Impacts of Water Shortages for Steam-electric Water User Groups (\$millions)			
Decade	Lost income due to reduced electrical generation	Lost state and local business tax revenues due to reduced electrical generation	Lost jobs due to reduced electrical generation
2010	\$1.90	\$0.27	6
2020	\$1,043.13	\$149.73	3,546
2030	\$1,046.13	\$150.16	3,556
2040	\$1,802.39	\$258.71	6,127
2050	\$1,909.17	\$274.03	6,490
2060	\$2,238.54	\$321.31	7,605

*Changes to Income and business taxes are collectively equivalent to a decrease in gross state product, which is analogous to gross domestic product measured at the state rather than national level.

2.7 Social Impacts of Water Shortages

As discussed previously, estimated social impacts focus on changes in population and school enrollment. In 2010, estimated population losses total 2,393 with corresponding reductions in school enrollment of 675 students (Table 14). In 2060, population in the region would decline by 25,988 people and school enrollment would fall by 4,807 students.

Table 14: Social Impacts of Water Shortages (2010-2060)		
Year	Population Losses	Declines in School Enrollment
2010	2,393	675
2020	10,174	2,886
2030	11,876	3,146
2040	17,647	3,261
2050	19,601	3,620
2060	25,988	4,807

2.8 Distribution of Impacts by Major River Basin

Administrative rules require that impacts are presented by both planning region and major river basin. To meet rule requirements, impacts were allocated among basins based on the distribution of water shortages in relevant basins. For example, if 50 percent of water shortages in River Basin A and 50 percent occur in River Basin B, then impacts were split equally among the two basins. Table 15 displays the results.

Table 15: Distribution of Impacts by Major River Basin (2010-2060)						
Water Use	2010	2020	2030	2040	2050	2060
Irrigation						
Brazos	<1%	<1%	<1%	<1%	<1%	<1%
Brazos-Colorado	51%	52%	52%	52%	53%	51%
Colorado	3%	3%	3%	3%	3%	3%
Colorado-Lavaca	31%	32%	33%	34%	35%	38%
Lavaca	14%	13%	12%	10%	9%	7%
Livestock						
Brazos	24%	24%	24%	24%	24%	24%
Colorado	40%	40%	40%	40%	40%	40%
Colorado-Lavaca	30%	30%	30%	30%	30%	30%
Lavaca	6%	6%	6%	6%	6%	6%
Manufacturing						
Colorado	64%	73%	77%	79%	80%	80%
Colorado-Lavaca	0%	0%	0%	0%	0%	1%
Guadalupe	5%	3%	2%	2%	2%	2%
Lavaca	31%	23%	21%	19%	18%	17%
Mining						
Brazos	<1%	<1%	<1%	<1%	<1%	<1%
Brazos-Colorado	<1%	<1%	<1%	<1%	<1%	<1%
Colorado	99%	98%	97%	97%	95%	95%
Lavaca	1%	1%	2%	2%	3%	3%
Municipal						
Brazos	<1%	<1%	<1%	<1%	<1%	<1%
Colorado	98%	99%	99%	99%	100%	100%
Guadalupe	0%	0%	0%	0%	0%	0%
Lavaca	2%	1%	1%	1%	0%	0%
Steam-electric						
Brazos-Colorado	0%	0%	0%	0%	0%	<1%
Colorado	100%	100%	100%	100%	100%	>99%

Appendix 1: Economic Data for Individual IMPLAN Sectors for Lower Colorado Regional Water Planning Area

Economic Data for Agricultural Water User Groups (\$millions)								
Water Use Category	IMPLAN Sector	IMPLAN Code	Total Sales	Intermediate Sales	Final Sales	Jobs	Income	Business Taxes
Irrigation	All other crop farming (rice)	10	\$60.66	\$54.54	\$6.12	774	\$29.71	\$1.17
Irrigation	Fruit Farming	5	\$28.03	\$3.74	\$24.45	691	\$16.06	\$0.61
Irrigation	Rice milling	49	\$21.75	\$0.17	\$21.58	36	\$2.49	\$0.15
Irrigation	Tree Nut Farming	4	\$16.71	\$8.95	\$7.76	295	\$11.56	\$0.41
Irrigation	Grain Farming	2	\$2.32	\$0.11	\$2.21	67	\$1.07	\$0.04
Irrigation	Vegetable and Melon Farming	3	\$1.83	\$0.09	\$1.74	34	\$1.34	\$0.02
Irrigation	Cotton Farming	8	\$0.59	\$0.01	\$0.58	5	\$0.22	\$0.01
Irrigation	Oilseed Farming	1	\$0.20	\$0.01	\$0.20	3	\$0.10	\$0.00
	Total irrigation		\$132.09	\$67.62	\$64.64	1,905	\$62.55	\$2.41
Livestock	Cattle ranching and farming	11	\$469.96	\$325.87	\$144.09	10,040	\$37.13	\$9.88
Livestock	Cheese manufacturing	64	\$178.60	\$73.97	\$104.63	241	\$12.97	\$1.09
Livestock	Meat processed from carcasses	68	\$110.94	\$32.73	\$78.21	258	\$10.87	\$0.56
Livestock	Fluid milk manufacturing	62	\$79.43	\$19.11	\$60.32	133	\$9.13	\$0.57
Livestock	Rendering and meat byproduct processing	69	\$48.31	\$26.81	\$21.50	91	\$11.48	\$0.33
Livestock	Animal production- except cattle and poultry	13	\$44.98	\$38.14	\$6.84	2,201	\$4.37	\$0.69
Livestock	Poultry and egg production	12	\$33.41	\$26.18	\$7.22	230	\$11.25	\$0.11
Livestock	Animal- except poultry- slaughtering	67	\$26.65	\$7.13	\$19.53	70	\$2.43	\$0.13
	Total livestock		\$992.27	\$549.93	\$442.34	13,264	\$99.62	\$13.36
	Total agriculture		\$1,124.36	\$617.55	\$506.99	15169	\$162.17	\$15.77
Based on year 2006 data from the Minnesota IMPLAN Group, Inc.								

Economic Data for Mining and Steam-electric Water User Groups (\$millions)								
Water Use Category	IMPLAN Sector	IMPLAN Code	Intermediate		Jobs	Income	Business Taxes	
			Total Sales	Sales				
Mining	Oil and gas extraction	19	\$1,901.89	\$1,766.26	1,831	\$1,095.27	\$114.04	
Mining	Support activities for oil and gas operations	28	\$368.31	\$51.16	1,553	\$333.91	\$15.15	
Mining	Drilling oil and gas wells	27	\$120.05	\$0.60	200	\$33.21	\$4.38	
Mining	Sand- gravel- clay- and refractory mining	25	\$114.95	\$12.13	568	\$68.27	\$3.28	
Mining	Stone mining and quarrying	24	\$66.46	\$6.84	249	\$39.02	\$0.35	
Mining	Support activities for other mining	29	\$2.74	\$0.04	20	\$0.91	\$0.11	
Mining	Other nonmetallic mineral mining	26	\$2.30	\$0.23	11	\$1.06	\$0.06	
Mining	Coal mining	20	\$1.94	\$0.73	7	\$0.73	\$0.16	
Mining	Iron ore mining	21	\$0.00	\$0.00	0	\$0.00	\$0.00	
Mining	Copper- nickel- lead- and zinc mining	22	\$0.00	\$0.00	0	\$0.00	\$0.00	
Mining	Gold- silver- and other metal ore mining	23	\$0.00	\$0.00	0	\$0.00	\$0.00	
Total Mining	NA		\$2,578.62	\$1,837.98	\$740.64	\$4,439.00	\$1,572.37	\$137.52
Steam-electric	Power generation and supply		\$1,342.07	\$377.55	\$964.52	2,823	\$932.02	\$158.93

Based on year 2006 data from the Minnesota IMPLAN Group, Inc.

Economic Data for Manufacturing Water User Groups (\$millions)

Water Use Category	IMPLAN Sector	IMPLAN Code	Intermediate		Final Sales	Jobs	Income	Business Taxes
			Total Sales	Sales				
Manufacturing	Electronic computer manufacturing	302	\$24,498.91	\$5,702.75	\$18,796.15	9,746	\$1,613.72	\$126.44
Manufacturing	Semiconductors and related device manufacturing	311	\$11,287.74	\$6,007.64	\$5,280.10	12,094	\$2,696.34	\$76.30
Manufacturing	New residential 1-unit structures- all	33	\$3,320.82	\$0.00	\$3,320.81	21,394	\$1,175.14	\$18.50
Manufacturing	Commercial and institutional buildings	38	\$1,917.68	\$0.00	\$1,917.68	18,651	\$1,006.96	\$12.41
Manufacturing	Pharmaceutical and medicine manufacturing	160	\$1,607.56	\$293.78	\$1,313.78	1,747	\$455.37	\$10.51
Manufacturing	All other electronic component manufacturing	312	\$867.97	\$497.39	\$370.58	3,664	\$297.15	\$5.02
Manufacturing	Other new construction	41	\$840.59	\$0.00	\$840.59	8,559	\$467.01	\$3.68
Manufacturing	Plastics and rubber industry machinery	263	\$598.81	\$26.67	\$572.13	1,906	\$306.80	\$4.48
Manufacturing	Telephone apparatus manufacturing	306	\$592.57	\$14.51	\$578.06	657	\$106.99	\$3.43
Manufacturing	New residential additions and alterations-all	35	\$476.81	\$0.00	\$476.80	2,548	\$186.29	\$2.63
Manufacturing	Petroleum refineries	142	\$419.22	\$155.83	\$263.40	18	\$238.69	\$8.68
Manufacturing	Highway- street- bridge- and tunnel construct	39	\$412.91	\$0.00	\$412.91	3,612	\$215.66	\$2.75
Manufacturing	New multifamily housing structures- all	34	\$370.60	\$0.00	\$370.59	3,110	\$181.41	\$1.05
Manufacturing	Jewelry and silverware manufacturing	380	\$333.02	\$6.72	\$326.30	1,297	\$112.38	\$1.80
Manufacturing	Ready-mix concrete manufacturing	192	\$312.44	\$1.52	\$310.92	1,084	\$107.69	\$2.73
Manufacturing	Surgical appliance and supplies manufacturing	376	\$299.56	\$74.76	\$224.79	675	\$166.49	\$1.49
Manufacturing	Water- sewer- and pipeline construction	40	\$297.69	\$0.00	\$297.70	2,364	\$138.34	\$2.00
Manufacturing	Construction machinery manufacturing	259	\$279.00	\$38.08	\$240.93	392	\$51.55	\$1.55
Manufacturing	Other communications equipment manufacturing	308	\$240.22	\$137.70	\$102.52	693	\$67.04	\$1.29
Manufacturing	Industrial process variable instruments	316	\$230.83	\$72.94	\$157.89	858	\$94.05	\$1.27
Manufacturing	Soft drink and ice manufacturing	85	\$224.93	\$12.56	\$212.37	338	\$41.55	\$1.84
Manufacturing	Petrochemical manufacturing	147	\$214.99	\$98.50	\$116.49	27	\$17.12	\$0.97
Manufacturing	Lighting fixture manufacturing	326	\$212.77	\$0.14	\$212.63	856	\$70.99	\$1.75
Manufacturing	Commercial printing	139	\$208.45	\$103.56	\$104.89	2,468	\$147.24	\$1.82
Manufacturing	Semiconductor machinery manufacturing	268	\$193.53	\$36.57	\$156.96	305	\$45.53	\$0.96
Manufacturing	Plastics plumbing fixtures and all other plastics	177	\$192.98	\$139.80	\$53.18	959	\$74.55	\$1.29
Manufacturing	All other manufacturing	Various	\$6,193.72	\$1,511.54	\$4,682.18	27,394	\$2,193.82	\$51.48
Manufacturing	Total manufacturing	NA	\$56,646.30	\$14,932.96	\$41,713.34	127,416	\$12,275.86	\$348.07

Based on year 2006 data from the Minnesota IMPLAN Group, Inc.

Economic Data for Municipal Water User Groups (\$millions)

Water Use Category	IMPLAN Sector	IMPLAN Code	Intermediate			Jobs	Income	Business Taxes
			Total Sales	Sales	Final Sales			
Municipal	Wholesale trade	390	\$10,178.94	\$4,873.30	\$5,305.64	45,128	\$5,361.62	\$1,502.90
Municipal	Real estate	431	\$6,309.70	\$2,497.72	\$3,811.98	30,663	\$3,651.19	\$776.89
Municipal	Owner-occupied dwellings	509	\$5,564.52	\$0.00	\$5,564.52	0	\$4,310.65	\$657.97
Municipal	State & Local Non-Education	504	\$5,125.29	-\$0.01	\$5,125.29	77,431	\$5,125.29	\$0.00
Municipal	Food services and drinking places	481	\$3,452.49	\$440.88	\$3,011.61	66,214	\$1,511.16	\$176.53
Municipal	State & Local Education	503	\$3,007.31	\$0.00	\$3,007.30	68,855	\$3,007.30	\$0.00
Municipal	Offices of physicians- dentists- and other he	465	\$2,950.97	\$0.00	\$2,950.97	23,663	\$2,104.31	\$18.48
Municipal	Telecommunications	422	\$2,932.63	\$1,007.30	\$1,925.32	8,188	\$1,210.29	\$202.61
Municipal	Software publishers	417	\$2,728.88	\$313.45	\$2,415.43	7,518	\$1,535.59	\$24.39
Municipal	Monetary authorities and depository credit in	430	\$2,223.88	\$732.44	\$1,491.44	8,321	\$1,561.65	\$28.45
Municipal	Architectural and engineering services	439	\$2,207.35	\$1,391.44	\$815.91	17,617	\$1,198.94	\$9.90
Municipal	Hospitals	467	\$2,112.08	\$0.00	\$2,112.08	17,768	\$1,151.85	\$14.70
Municipal	Insurance carriers	427	\$2,002.12	\$583.81	\$1,418.31	7,713	\$745.18	\$92.77
Municipal	Warehousing and storage	400	\$1,852.94	\$1,704.24	\$148.70	30,873	\$1,354.05	\$9.63
Municipal	Legal services	437	\$1,613.89	\$1,024.27	\$589.62	10,916	\$1,035.79	\$32.03
Municipal	Securities- commodity contracts- investments	426	\$1,547.14	\$1,027.45	\$519.70	12,953	\$554.51	\$16.41
Municipal	Motor vehicle and parts dealers	401	\$1,418.75	\$154.27	\$1,264.47	12,081	\$737.12	\$208.18
Municipal	Nondepository credit intermediation and rela	425	\$1,327.96	\$812.96	\$514.99	7,539	\$793.32	\$60.69
Municipal	Management consulting services	444	\$1,229.18	\$946.19	\$282.99	8,545	\$657.82	\$5.13
Municipal	Custom computer programming services	441	\$1,179.82	\$98.33	\$1,081.49	10,095	\$998.26	\$6.21
Municipal	Insurance agencies- brokerages- and related	428	\$1,078.66	\$632.98	\$445.67	7,705	\$914.89	\$5.69
Municipal	Food and beverage stores	405	\$1,059.15	\$141.60	\$917.55	17,064	\$549.69	\$120.19
Municipal	Federal Non-Military	506	\$963.45	\$0.00	\$963.45	7,791	\$963.45	\$0.00
Municipal	All other miscellaneous professional and tech	450	\$922.27	\$823.43	\$98.84	1,894	\$332.44	\$6.66
Municipal	Building material and garden supply stores	404	\$903.30	\$140.09	\$763.21	8,855	\$440.94	\$134.02
Municipal	All other municipal sectors	NA	\$6,193.72	\$1,511.54	\$4,682.18	27,394	\$2,193.82	\$51.48
	Total municipal	NA	\$96,908.91	\$31,257.19	\$65,651.72	883,845	\$57,858.80	\$5,225.90

Based on year 2006 data from the Minnesota IMPLAN Group, Inc.

Appendix 2: Impacts by Water User Group

Irrigation (\$millions)						
	2010	2020	2030	2040	2050	2060
Bastrop County						
Reduced income from reduced crop production	\$0.0133	\$0.0056	\$0.0045	\$0.0035	\$0.0027	\$0.0019
Reduced business taxes from reduced crop production	\$0.0015	\$0.0006	\$0.0005	\$0.0004	\$0.0003	\$0.0002
Reduced jobs from reduced crop production	0	0	0	0	0	0
Colorado County						
Reduced income from curtailed rice production and milling activity	\$6.90	\$5.89	\$4.91	\$3.96	\$3.04	\$2.16
Reduced business taxes from curtailed rice production and milling activity	\$0.80	\$0.68	\$0.57	\$0.46	\$0.35	\$0.25
Reduced jobs from curtailed rice production and milling activity	91	78	65	52	40	28
Fayette County						
Reduced income from reduced crop production	\$0.00	\$0.01	\$0.01	\$0.01	\$0.01	\$0.01
Reduced business taxes from reduced crop production	\$0.00	\$0.00	\$0.00	\$0.00	\$0.00	\$0.00
Reduced jobs from reduced crop production	0	0	0	0	0	0
Matagorda County						
Reduced income from curtailed rice production and milling activity	\$70.93	\$67.75	\$63.99	\$60.38	\$56.92	\$53.58
Reduced business taxes from curtailed rice production and milling activity	\$8.21	\$7.84	\$7.41	\$6.99	\$6.59	\$6.20
Reduced jobs from curtailed rice production and milling activity	935	893	844	796	751	706
Mills County						
Reduced income from reduced crop production	\$0.04	\$0.03	\$0.03	\$0.02	\$0.02	\$0.02
Reduced business taxes from reduced crop production	\$0.00	\$0.00	\$0.00	\$0.00	\$0.00	\$0.00
Reduced jobs from reduced crop production	0	0	0	0	0	0
Wharton County						
Reduced income from curtailed rice production and milling activity	\$13.03	\$11.98	\$10.97	\$9.99	\$9.05	\$5.48
Reduced business taxes from curtailed rice production and milling activity	\$1.51	\$1.39	\$1.27	\$1.16	\$1.05	\$0.63
Reduced jobs from curtailed rice production and milling activity	172	158	145	132	119	72

Livestock (\$millions)						
	2010	2020	2030	2040	2050	2060
Burnet County						
Annual costs of hauling water by tanker	\$0.55	\$0.55	\$0.55	\$0.55	\$0.55	\$0.55
Colorado County						
Annual costs of hauling water by tanker	\$0.60	\$0.60	\$0.60	\$0.60	\$0.60	\$0.60
Fayette County						
Annual costs of hauling water by tanker	\$0.53	\$0.53	\$0.53	\$0.53	\$0.53	\$0.53
Llano County						
Annual costs of hauling water by tanker	\$1.49	\$1.49	\$1.49	\$1.49	\$1.49	\$1.49
Matagorda County						
Annual costs of hauling water by tanker	\$1.34	\$1.34	\$1.34	\$1.34	\$1.34	\$1.34

Manufacturing (\$millions)						
	2010	2020	2030	2040	2050	2060
Bastrop County						
Reduced income from reduced manufacturing activity	\$0.47	\$0.99	\$1.64	\$2.22	\$2.69	\$7.01
Reduced business taxes from reduced manufacturing activity	\$0.04	\$0.08	\$0.13	\$0.18	\$0.22	\$0.58
Reduced jobs from reduced manufacturing activity	8	18	29	39	48	124
Fayette County						
Reduced income from reduced manufacturing activity	\$3.13	\$9.73	\$13.06	\$16.26	\$19.04	\$22.51
Reduced business taxes from reduced manufacturing activity	\$0.35	\$1.08	\$1.45	\$1.80	\$2.11	\$2.49
Reduced jobs from reduced manufacturing activity	78	243	327	407	477	563
Hays County						
Reduced income from reduced manufacturing activity	\$1.04	\$2.37	\$7.42	\$10.11	\$12.54	\$29.53
Reduced business taxes from reduced manufacturing activity	\$0.07	\$0.15	\$0.47	\$0.64	\$0.79	\$1.87
Reduced jobs from reduced manufacturing activity	11	24	75	102	127	299
Matagorda County						
Reduced income from reduced manufacturing activity	\$0.00	\$0.00	\$0.00	\$0.00	\$0.00	\$0.41
Reduced business taxes from reduced manufacturing activity	\$0.00	\$0.00	\$0.00	\$0.00	\$0.00	\$0.01
Reduced jobs from reduced manufacturing activity	0	0	0	0	0	1
Wharton County						
Reduced income from reduced manufacturing activity	\$0.00	\$0.00	\$0.00	\$0.00	\$0.00	\$0.0169
Reduced business taxes from reduced manufacturing activity	\$0.00	\$0.00	\$0.00	\$0.00	\$0.00	\$0.0018
Reduced jobs from reduced manufacturing activity	0	0	0	0	0	0

Mining (\$millions)						
	2010	2020	2030	2040	2050	2060
Burnet County						
Reduced income from reduced mining activity	\$1.45	\$1.62	\$1.69	\$1.76	\$1.80	\$1.89
Reduced business taxes from reduced mining activity	\$0.08	\$0.09	\$0.09	\$0.09	\$0.10	\$0.10
Reduced jobs from reduced mining activity	14	16	17	18	18	19
Colorado County						
Reduced income from reduced mining activity	\$16.12	\$15.20	\$13.63	\$11.50	\$8.83	\$9.16
Reduced business taxes from reduced mining activity	\$1.12	\$1.05	\$0.94	\$0.80	\$0.61	\$0.63
Reduced jobs from reduced mining activity	145	137	123	103	79	82
Fayette County						
Reduced income from reduced mining activity	\$0.00	\$0.00	\$0.08	\$0.11	\$0.11	\$0.11
Reduced business taxes from reduced mining activity	\$0.00	\$0.00	\$0.01	\$0.01	\$0.01	\$0.01
Reduced jobs from reduced mining activity	0	0	1	1	1	1

Steam-electric (\$millions)						
	2010	2020	2030	2040	2050	2060
Bastrop County						
Reduced income from reduced electrical generation	\$0.00	\$0.00	\$0.00	\$31.03	\$67.39	\$67.39
Reduced business taxes from reduced electrical generation	\$0.00	\$0.00	\$0.00	\$4.45	\$9.67	\$9.67
Reduced jobs from reduced electrical generation	0	0	0	105	229	229
Fayette County						
Reduced income from reduced electrical generation	\$0.00	\$0.00	\$0.00	\$707.63	\$707.63	\$907.02
Reduced business taxes from reduced electrical generation	\$0.00	\$0.00	\$0.00	\$101.57	\$101.57	\$130.19
Reduced jobs from reduced electrical generation	0	0	0	2406	2406	3083
Matagorda County						
Reduced income from reduced electrical generation	\$1.90	\$1,043.13	\$1,043.13	\$1,043.13	\$1,043.13	\$1,045.49
Reduced business taxes from reduced electrical generation	\$0.27	\$149.73	\$149.73	\$149.73	\$149.73	\$150.06
Reduced jobs from reduced electrical generation	6	3,546	3,546	3,546	3,546	3,554
Travis County						
Reduced income from reduced electrical generation	\$0.00	\$0.00	\$2.99	\$20.60	\$91.01	\$217.24
Reduced business taxes from reduced electrical generation	\$0.00	\$0.00	\$0.43	\$2.96	\$13.06	\$31.18
Reduced jobs from reduced electrical generation	0	0	10	70	309	738
Wharton County						
Reduced income from reduced electrical generation	\$0.00	\$0.00	\$0.00	\$0.00	\$0.00	\$1.41
Reduced business taxes from reduced electrical generation	\$0.00	\$0.00	\$0.00	\$0.00	\$0.00	\$0.20
Reduced jobs from reduced electrical generation	0	0	0	0	0	0

Municipal (\$millions)						
	2010	2020	2030	2040	2050	2060
Aqua WSC						
Monetary value of domestic water shortages	\$0.00	\$0.00	\$0.62	\$26.11	\$75.35	\$142.24
Lost income from reduced commercial business activity	\$0.00	\$0.00	\$0.00	\$0.00	\$0.00	\$52.86
Lost jobs due to reduced commercial business activity	0	0	0	0	0	1,176
Lost state and local taxes from reduced commercial business activity	\$0.00	\$0.00	\$0.00	\$0.00	\$0.00	\$5.63
Lost utility revenues	\$0.00	\$0.00	\$1.10	\$6.79	\$11.39	\$17.24
Austin						
Monetary value of domestic water shortages	\$0.00	\$0.00	\$0.00	\$0.00	\$27.42	\$69.83
Lost utility revenues	\$0.00	\$0.00	\$0.00	\$0.00	\$46.14	\$95.28
Barton Creek West						
Monetary value of domestic water shortages	\$0.07	\$0.07	\$0.06	\$0.05	\$0.05	\$0.05
Lost utility revenues	\$0.10	\$0.10	\$0.09	\$0.09	\$0.09	\$0.09
Bastrop						
Monetary value of domestic water shortages	\$0.08	\$0.50	\$3.04	\$4.26	\$7.73	\$13.76
Lost income from reduced commercial business activity	\$0.00	\$0.00	\$0.00	\$16.21	\$24.16	\$68.28
Lost jobs due to reduced commercial business activity	0	0	0	361	537	1,519
Lost state and local taxes from reduced commercial business activity	\$0.00	\$0.00	\$0.00	\$1.72	\$2.57	\$7.27
Lost utility revenues	\$0.12	\$1.49	\$2.81	\$4.74	\$6.33	\$8.32
Bastrop County WCID #2						
Monetary value of domestic water shortages	\$0.00	\$0.00	\$0.00	\$0.00	\$0.00	\$0.18
Lost utility revenues	\$0.00	\$0.00	\$0.00	\$0.00	\$0.00	\$0.29
Bee Cave Village						
Monetary value of domestic water shortages	\$19.27	\$24.02	\$28.74	\$32.96	\$36.04	\$39.16
Lost income from reduced commercial business activity	\$28.34	\$36.37	\$44.33	\$51.44	\$56.65	\$61.92
Lost jobs due to reduced commercial business activity	457	586	715	829	913	998
Lost state and local taxes from reduced commercial business activity	\$2.55	\$3.27	\$3.99	\$4.63	\$5.10	\$5.57
Lost utility revenues	\$1.85	\$2.32	\$2.78	\$3.20	\$3.50	\$3.81

Municipal (cont.)						
	2010	2020	2030	2040	2050	2060
Bertram						
Monetary value of domestic water shortages	\$0.00	\$0.00	\$0.00	\$0.03	\$0.10	\$0.21
Lost utility revenues	\$0.00	\$0.00	\$0.00	\$0.05	\$0.15	\$0.26
Briarcliff Village						
Monetary value of domestic water shortages	\$0.00	\$0.00	\$0.06	\$0.16	\$0.24	\$0.30
Lost utility revenues	\$0.00	\$0.00	\$0.09	\$0.17	\$0.23	\$0.30
Buda						
Monetary value of domestic water shortages	\$0.00	\$0.00	\$0.38	\$1.18	\$8.05	\$11.86
Lost utility revenues	\$0.00	\$0.00	\$0.61	\$1.50	\$2.55	\$3.42
Cimarron Park Water Company						
Monetary value of domestic water shortages	\$2.82	\$5.66	\$5.00	\$6.41	\$10.02	\$11.84
Lost income from reduced commercial business activity	\$0.00	\$0.00	\$0.69	\$0.98	\$1.33	\$1.62
Lost jobs due to reduced commercial business activity	0	0	28	39	54	65
Lost state and local taxes from reduced commercial business activity	\$0.00	\$0.00	\$0.11	\$0.15	\$0.21	\$0.25
Lost utility revenues	\$0.30	\$0.47	\$0.65	\$0.84	\$1.06	\$1.25
Cottonwood Shores						
Monetary value of domestic water shortages	\$0.05	\$2.98	\$7.22	\$11.67	\$17.16	\$23.01
Lost income from reduced commercial business activity	\$0.00	\$0.22	\$1.02	\$1.69	\$2.43	\$3.34
Lost jobs due to reduced commercial business activity	0	9	41	68	98	134
Lost state and local taxes from reduced commercial business activity	\$0.00	\$0.03	\$0.16	\$0.26	\$0.38	\$0.52
Lost utility revenues	\$0.05	\$0.39	\$0.76	\$1.19	\$1.66	\$2.24
County-other (Bastrop)						
Monetary value of domestic water shortages	\$0.00	\$1.05	\$16.93	\$47.78	\$72.44	\$110.51
County-other (Blanco)						
Monetary value of domestic water shortages	\$0.00	\$0.00	\$0.00	\$0.00	\$0.05	\$0.08
County-other (Burnet)						
Monetary value of domestic water shortages	\$0.00	\$0.00	\$0.21	\$1.15	\$1.73	\$2.79

Municipal (cont.)						
	2010	2020	2030	2040	2050	2060
County-other (Colorado)						
Monetary value of domestic water shortages	\$0.11	\$0.11	\$0.11	\$0.10	\$0.10	\$0.09
County-other (Fayette)						
Monetary value of domestic water shortages	\$0.15	\$0.17	\$0.01	\$0.04	\$0.03	\$0.02
County-other (Hays)						
Monetary value of domestic water shortages	\$0.00	\$1.01	\$17.11	\$34.05	\$63.12	\$90.11
County-other (Llano)						
Monetary value of domestic water shortages	\$0.00	\$0.00	\$0.04	\$0.23	\$0.46	\$0.75
County-other (Mills)						
Monetary value of domestic water shortages	\$0.000	\$0.000	\$0.000	\$0.000	\$0.031	\$0.055
County-other (Travis)						
Monetary value of domestic water shortages	\$0.001	\$0.001	\$0.001	\$0.002	\$0.004	\$0.004
Creedmoor MAHA WSC						
Monetary value of domestic water shortages	\$0.00	\$6.49	\$10.21	\$11.95	\$13.38	\$15.34
Lost income from reduced commercial business activity	\$0.00	\$1.22	\$3.42	\$4.16	\$4.88	\$5.67
Lost jobs due to reduced commercial business activity	0	38	108	131	154	179
Lost state and local taxes from reduced commercial business activity	\$0.00	\$0.17	\$0.49	\$0.59	\$0.70	\$0.81
Lost utility revenues	\$0.00	\$0.79	\$1.00	\$1.16	\$1.31	\$1.48
Dripping Springs						
Monetary value of domestic water shortages	\$5.72	\$24.82	\$32.45	\$41.43	\$57.16	\$65.95
Lost income from reduced commercial business activity	\$3.28	\$20.82	\$28.93	\$37.16	\$47.36	\$55.37
Lost jobs due to reduced commercial business activity	73	463	644	827	1,054	1,232
Lost state and local taxes from reduced commercial business activity	\$0.35	\$2.22	\$3.08	\$3.95	\$5.04	\$5.89
Lost utility revenues	\$1.05	\$2.47	\$3.28	\$4.10	\$5.12	\$5.92
Dripping Springs WSC						
Monetary value of domestic water shortages	\$0.00	\$0.00	\$0.00	\$0.01	\$0.27	\$0.59
Lost utility revenues	\$0.00	\$0.00	\$0.00	\$0.03	\$0.42	\$0.72

Municipal (cont.)						
	2010	2020	2030	2040	2050	2060
Elgin						
Monetary value of domestic water shortages	\$0.00	\$4.34	\$10.34	\$19.91	\$31.30	\$41.55
Lost income from reduced commercial business activity	\$0.00	\$0.00	\$0.00	\$12.10	\$18.54	\$53.43
Lost jobs due to reduced commercial business activity	0	0	0	269	413	1,189
Lost state and local taxes from reduced commercial business activity	\$0.00	\$0.00	\$0.00	\$1.29	\$1.97	\$5.69
Lost utility revenues	\$0.00	\$1.11	\$2.15	\$3.72	\$5.01	\$6.64
Fayette WSC						
Monetary value of domestic water shortages	\$0.00	\$0.33	\$2.92	\$4.96	\$7.48	\$13.97
Lost income from reduced commercial business activity	\$0.00	\$0.00	\$0.00	\$0.00	\$0.00	\$0.58
Lost jobs due to reduced commercial business activity	0	0	0	0	0	23
Lost state and local taxes from reduced commercial business activity	\$0.00	\$0.00	\$0.00	\$0.00	\$0.00	\$0.09
Lost utility revenues	\$0.00	\$0.47	\$1.01	\$1.43	\$1.95	\$2.62
Goforth WSC						
Monetary value of domestic water shortages	\$0.10	\$0.26	\$0.48	\$0.70	\$0.98	\$1.09
Lost utility revenues	\$0.02	\$0.04	\$0.06	\$0.07	\$0.09	\$0.10
Goldthwaite						
Monetary value of domestic water shortages	\$10.21	\$11.26	\$11.42	\$11.30	\$11.16	\$11.14
Lost income from reduced commercial business activity	\$6.71	\$7.45	\$7.56	\$7.48	\$7.37	\$7.36
Lost jobs due to reduced commercial business activity	203	226	229	226	223	223
Lost state and local taxes from reduced commercial business activity	\$1.07	\$1.18	\$1.20	\$1.19	\$1.17	\$1.17
Lost utility revenues	\$0.99	\$1.10	\$1.11	\$1.10	\$1.09	\$1.08
Granite Shoals						
Monetary value of domestic water shortages	\$0.00	\$0.00	\$0.00	\$0.00	\$0.02	\$0.12
Lost utility revenues	\$0.00	\$0.00	\$0.00	\$0.00	\$0.03	\$0.19
Jonestown						
Monetary value of domestic water shortages	\$1.28	\$4.38	\$4.37	\$6.24	\$8.57	\$10.34
Lost income from reduced commercial business activity	\$0.00	\$0.00	\$1.86	\$2.70	\$3.36	\$8.17
Lost jobs due to reduced commercial business activity	0	0	41	60	75	182
Lost state and local taxes from reduced commercial business activity	\$0.00	\$0.00	\$0.20	\$0.29	\$0.36	\$0.87
Lost utility revenues	\$0.26	\$0.46	\$0.65	\$0.82	\$0.95	\$1.10

Municipal (cont.)						
	2010	2020	2030	2040	2050	2060
Kingsland WSC						
Monetary value of domestic water shortages	\$0.31	\$0.45	\$0.44	\$0.44	\$0.47	\$0.51
Lost utility revenues	\$0.35	\$0.44	\$0.43	\$0.43	\$0.46	\$0.50
Lake LBJ MUD						
Monetary value of domestic water shortages	\$0.14	\$0.33	\$0.43	\$0.49	\$0.63	\$0.83
Lost utility revenues	\$0.25	\$0.53	\$0.62	\$0.70	\$0.80	\$0.93
Lakeway						
Monetary value of domestic water shortages	\$15.03	\$38.28	\$50.54	\$37.90	\$42.37	\$56.68
Lost income from reduced commercial business activity	\$0.00	\$0.00	\$20.19	\$27.77	\$33.43	\$39.11
Lost jobs due to reduced commercial business activity	0	0	449	618	744	870
Lost state and local taxes from reduced commercial business activity	\$0.00	\$0.00	\$2.15	\$2.96	\$3.56	\$4.16
Lost utility revenues	\$3.08	\$4.79	\$6.43	\$7.95	\$9.07	\$10.21
Llano						
Monetary value of domestic water shortages	\$22.12	\$23.75	\$23.99	\$24.17	\$24.48	\$24.98
Lost income from reduced commercial business activity	\$21.04	\$22.66	\$22.90	\$23.08	\$23.37	\$23.87
Lost jobs due to reduced commercial business activity	\$17.35	\$18.69	\$18.88	\$19.03	\$19.28	\$19.69
Lost state and local taxes from reduced commercial business activity	456	491	496	500	506	517
Lost utility revenues						
Manor						
Monetary value of domestic water shortages	\$0.00	\$8.20	\$11.97	\$22.74	\$25.07	\$27.44
Lost income from reduced commercial business activity	\$0.00	\$6.03	\$8.17	\$20.34	\$23.31	\$26.34
Lost jobs due to reduced commercial business activity	0	134	182	452	519	586
Lost state and local taxes from reduced commercial business activity	\$0.00	\$0.64	\$0.87	\$2.16	\$2.48	\$2.80
Lost utility revenues	\$0.00	\$1.72	\$2.15	\$2.55	\$2.84	\$3.14
Manville WSC						
Monetary value of domestic water shortages	\$0.00	\$0.00	\$6.12	\$39.06	\$45.99	\$52.74
Lost income from reduced commercial business activity	\$0.00	\$0.00	\$0.00	\$14.03	\$17.24	\$20.55
Lost jobs due to reduced commercial business activity	0	0	0	442	544	648
Lost state and local taxes from reduced commercial business activity	\$0.00	\$0.00	\$0.00	\$2.00	\$2.46	\$2.93
Lost utility revenues	\$0.00	\$0.00	\$1.52	\$4.00	\$4.73	\$5.56

Municipal (cont.)						
	2010	2020	2030	2040	2050	2060
Marble Falls						
Monetary value of domestic water shortages	\$0.00	\$0.22	\$1.41	\$9.08	\$12.43	\$18.68
Lost utility revenues	\$0.00	\$0.39	\$1.79	\$3.15	\$3.95	\$4.86
Meadow Lakes						
Monetary value of domestic water shortages	\$2.63	\$6.32	\$9.82	\$20.20	\$24.42	\$27.58
Lost income from reduced commercial business activity	\$0.00	\$0.00	\$2.50	\$7.20	\$8.51	\$9.96
Lost jobs due to reduced commercial business activity	0	0	79	227	268	314
Lost state and local taxes from reduced commercial business activity	\$0.00	\$0.00	\$0.36	\$1.03	\$1.21	\$1.42
Lost utility revenues	\$0.63	\$1.14	\$1.70	\$2.24	\$2.56	\$2.91
Mountain City						
Monetary value of domestic water shortages	\$0.04	\$0.04	\$0.04	\$0.03	\$0.03	\$0.03
Lost utility revenues	\$0.05	\$0.05	\$0.05	\$0.04	\$0.04	\$0.04
Pflugerville						
Monetary value of domestic water shortages	\$0.00	\$0.00	\$0.00	\$0.00	\$0.94	\$2.27
Lost utility revenues	\$0.00	\$0.00	\$0.00	\$0.00	\$1.68	\$3.63
Polonia WSC						
Monetary value of domestic water shortages	\$0.00	\$0.00	\$0.01	\$0.14	\$0.23	\$0.33
Lost utility revenues	\$0.00	\$0.00	\$0.01	\$0.03	\$0.05	\$0.06
Richland SUD						
Monetary value of domestic water shortages	\$0.00	\$0.00	\$0.00	\$0.003	\$0.003	\$0.005
Lost utility revenues	\$0.00	\$0.00	\$0.00	\$0.01	\$0.01	\$0.01
River Place on Lake Austin						
Monetary value of domestic water shortages	\$5.14	\$9.03	\$9.03	\$8.96	\$8.96	\$8.96
Lost utility revenues	\$1.13	\$1.63	\$1.63	\$1.62	\$1.62	\$1.62
Rolling Wood						
Monetary value of domestic water shortages	\$0.00	\$7.58	\$7.54	\$7.50	\$7.48	\$7.52
Lost income from reduced commercial business activity	\$0.00	\$3.04	\$3.03	\$3.01	\$3.00	\$3.02
Lost jobs due to reduced commercial business activity	0	96	95	95	95	95
Lost state and local taxes from reduced commercial business activity	\$0.00	\$0.43	\$0.43	\$0.43	\$0.43	\$0.43
Lost utility revenues	\$0.00	\$0.74	\$0.74	\$0.74	\$0.73	\$0.74

Municipal (cont.)						
	2010	2020	2030	2040	2050	2060
Round Rock						
Monetary value of domestic water shortages	\$0.19	\$3.02	\$5.30	\$10.62	\$12.62	\$14.64
Lost income from reduced commercial business activity	\$0.00	\$3.83	\$14.12	\$19.27	\$24.41	\$29.50
Lost jobs due to reduced commercial business activity	0	62	228	311	393	476
Lost state and local taxes from reduced commercial business activity	\$0.00	\$0.34	\$1.27	\$1.73	\$2.20	\$2.66
Lost utility revenues	\$0.31	\$0.67	\$1.05	\$1.32	\$1.61	\$1.90
Schulenburg						
Monetary value of domestic water shortages	\$0.00	\$0.00	\$0.00	\$0.04	\$0.11	\$0.30
Lost utility revenues	\$0.00	\$0.00	\$0.00	\$0.07	\$0.20	\$0.38
Smithville						
Monetary value of domestic water shortages	\$0.00	\$4.34	\$10.34	\$19.91	\$31.30	\$41.55
Lost income from reduced commercial business activity	\$0.00	\$0.00	\$0.00	\$0.00	\$1.14	\$2.13
Lost jobs due to reduced commercial business activity	0	0	0	0	36	67
Lost state and local taxes from reduced commercial business activity	\$0.00	\$0.00	\$0.00	\$0.00	\$0.16	\$0.30
Lost utility revenues	\$0.14	\$0.57	\$0.96	\$1.73	\$2.04	\$2.93
Travis Co. WCID #18						
Monetary value of domestic water shortages	\$0.00	\$0.00	\$0.00	\$0.00	\$0.16	\$0.45
Lost utility revenues	\$0.00	\$0.00	\$0.00	\$0.01	\$0.25	\$0.52
West Lake Hills						
Monetary value of domestic water shortages	\$0.00	\$36.95	\$41.31	\$43.91	\$46.77	\$49.82
Lost income from reduced commercial business activity	\$0.00	\$62.37	\$69.72	\$74.11	\$78.95	\$84.08
Lost jobs due to reduced commercial business activity	0	1,005	1,124	1,195	1,272	1,355
Lost state and local taxes from reduced commercial business activity	\$0.00	\$5.61	\$6.28	\$6.67	\$7.11	\$7.57
Lost utility revenues	\$0.00	\$3.63	\$4.06	\$4.31	\$4.59	\$4.89
Windermere Utility Co.						
Monetary value of domestic water shortages	\$0.00	\$44.80	\$44.37	\$43.95	\$43.95	\$43.95
Lost income from reduced commercial business activity	\$0.00	\$40.83	\$40.44	\$40.06	\$40.06	\$40.06
Lost jobs due to reduced commercial business activity	0	908	900	891	891	891
Lost state and local taxes from reduced commercial business activity	\$0.00	\$4.35	\$4.30	\$4.26	\$4.26	\$4.26
Lost utility revenues	\$0.00	\$4.07	\$4.03	\$3.99	\$3.99	\$3.99



TEXAS WATER DEVELOPMENT BOARD



James E. Herring, *Chairman*
Lewis H. McMahan, *Member*
Edward G. Vaughan, *Member*

J. Kevin Ward
Executive Administrator

Jack Hunt, *Vice Chairman*
Thomas Weir Labatt III, *Member*
Joe M. Crutcher, *Member*

June 15, 2010

Mr. Con Mims
Chairman, South Central Texas
Regional Water Planning Group
c/o Nueces River Authority
P.O. Box 349
Uvalde, Texas 78802-0349

Re: Socioeconomic Impact Analysis of Not Meeting Water Needs for the 2011 South Central Texas Regional Water Plan

Dear Chairman Mims:

We have received your request for technical assistance to complete the socioeconomic impact analysis of not meeting water needs. In response, enclosed is a report that describes our methodology and presents the results. Section 1 provides an overview of the methodology. Section 2 presents results at the regional level, and Appendix 2 show results for individual water user groups.

If you have any questions or comments, please feel free to contact me at (512) 463-7928 or by email at stuart.norvell@twdb.state.tx.us.

Sincerely,

Stuart D. Norvell
Manager, Water Planning Research and Analysis
Water Resources Planning Division

SN/ao

Enclosure

c: Sam Vaughn, HDR Inc
Matt Nelson, TWDB

Our Mission

To provide leadership, planning, financial assistance, information, and education for the conservation and responsible development of water for Texas.

P.O. Box 13231 • 1700 N. Congress Avenue • Austin, Texas 78711-3231
Telephone (512) 463-7847 • Fax (512) 475-2053 • 1-800-RELAYTX (for the hearing impaired)
www.twdb.state.tx.us • info@twdb.state.tx.us

TNRIS - Texas Natural Resources Information System • www.tnr.is.state.tx.us
A Member of the Texas Geographic Information Council (TGIC)



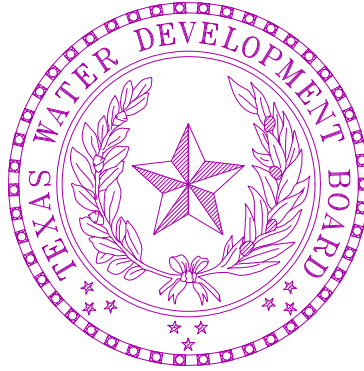

Socioeconomic Impacts of Projected Water Shortages for the South Central Texas Regional Water Planning Area (Region L)

Prepared in Support of the 2011 South Central Texas Regional Water Plan

Stuart D. Norvell, Managing Economist
Water Resources Planning Division
Texas Water Development Board
Austin, Texas

S. Doug Shaw, Agricultural Economist
Water Resources Planning Division
Texas Water Development Board
Austin, Texas

June 2010

Table of Contents

Section	Title	Page
	Introduction.....	3
1.0	Methodology.....	3
1.1	Economic Impacts of Water Shortages.....	3
1.1.1	General Approach.....	8
	General Assumptions and Clarifications of the Methodology.....	9
1.1.2	Impacts to Agriculture.....	9
	Irrigation.....	9
	Livestock.....	12
1.1.3	Impacts to Municipal Water User Groups.....	13
	Disaggregation of Municipal Water Demands.....	13
	Domestic Water Uses.....	14
	Commercial Businesses.....	17
	Water Utility Revenues.....	18
	Horticulture and Landscaping.....	18
	Recreational Impacts.....	19
1.1.4	Impacts to Industrial Water User Groups.....	20
	Manufacturing.....	20
	Mining.....	20
	Steam-electric.....	21
1.2	Social Impacts of Water Shortages.....	21
2.0	Results.....	22
2.1	Overview of Regional Economy.....	22
2.2	Impacts to Agricultural Water User Groups.....	24
2.3	Impacts to Municipal Water User Groups.....	24
2.4	Impacts to Manufacturing Water User Groups.....	25
2.5	Impacts to Mining Water User Groups.....	26
2.6	Impacts to Steam-electric Water User Groups.....	27
2.7	Social Impacts.....	27
2.8	Distribution of Impacts by Major River Basin.....	28
	Appendix 1: Economic Data for Individual IMPLAN Sectors.....	29
	Appendix 2: Impacts by Water User Group.....	33
Tables		
1	Crop Classifications and Corresponding IMPLAN Crop Sectors.....	10
2	Summary of Irrigated Crop Acreage and Water Demand.....	10
3	Average Gross Sales Revenues per Acre for Irrigated Crops.....	11
4	Description of Livestock Sectors.....	13
5	Water Use and Costs Parameters Used to Estimated Domestic Water Demand Functions.....	15
6	Economic Losses Associated with Domestic Water Shortages.....	17
7	Impacts of Municipal Water Shortages at Different Magnitudes of Shortages.....	20
8	Regional Baseline Economy by Water User Group.....	23
9	Economic Impacts of Water Shortages for Irrigation Water User Groups.....	24
10	Economic Impacts of Water Shortages for Municipal Water User Groups.....	24
11	Economic Impacts of Water Shortages for Manufacturing Water User Groups.....	25
12	Economic Impacts of Water Shortages for Mining Water User Groups.....	26
13	Economic Impacts of Water Shortages for Steam-electric Water User Groups.....	27
14	Social Impacts of Water Shortages.....	27
15	Distribution of Impacts by Major River Basin.....	28

Introduction

Water shortages during drought would likely curtail or eliminate economic activity in business and industries reliant on water. For example, without water farmers cannot irrigate; refineries cannot produce gasoline, and paper mills cannot make paper. Unreliable water supplies would not only have an immediate and real impact on existing businesses and industry, but they could also adversely affect economic development in Texas. From a social perspective, water supply reliability is critical as well. Shortages would disrupt activity in homes, schools and government and could adversely affect public health and safety. For all of the above reasons, it is important to analyze and understand how restricted water supplies during drought could affect communities throughout the state.

Administrative rules require that regional water planning groups evaluate the impacts of not meeting water needs as part of the regional water planning process, and rules direct TWDB staff to provide technical assistance: *“The executive administrator shall provide available technical assistance to the regional water planning groups, upon request, on water supply and demand analysis, including methods to evaluate the social and economic impacts of not meeting needs”* [(§357.7 (4)(A)]. Staff of the TWDB’s Water Resources Planning Division designed and conducted this report in support of the South Central Texas Regional Water Planning Group (Region L).

This document summarizes the results of our analysis and discusses the methodology used to generate the results. Section 1 outlines the overall methodology and discusses approaches and assumptions specific to each water use category (i.e., irrigation, livestock, mining, steam-electric, municipal and manufacturing). Section 2 presents the results for each category where shortages are reported at the regional planning area level and river basin level. Results for individual water user groups are not presented, but are available upon request.

1. Methodology

Section 1 provides a general overview of how economic and social impacts were measured. In addition, it summarizes important clarifications, assumptions and limitations of the study.

1.1 Economic Impacts of Water Shortages

1.1.1 General Approach

Economic analysis as it relates to water resources planning generally falls into two broad areas. Supply side analysis focuses on costs and alternatives of developing new water supplies or implementing programs that provide additional water from current supplies. Demand side analysis concentrates on impacts or benefits of providing water to people, businesses and the environment. Analysis in this report focuses strictly on demand side impacts. When analyzing the economic impacts of water shortages as defined in Texas water planning, three potential scenarios are possible:

- 1) Scenario 1 involves situations where there are physical shortages of raw surface or groundwater due to drought of record conditions. For example, City A relies on a reservoir with average conservation storage of 500 acre-feet per year and a firm yield of 100 acre feet. In 2010, the city uses about 50 acre-feet per year, but by 2030 their demands are expected to increase to 200

acre-feet. Thus, in 2030 the reservoir would not have enough water to meet the city's demands, and people would experience a shortage of 100 acre-feet assuming drought of record conditions. Under normal or average climatic conditions, the reservoir would likely be able to provide reliable water supplies well beyond 2030.

- 2) Scenario 2 is a situation where despite drought of record conditions, water supply sources can meet existing use requirements; however, limitations in water infrastructure would preclude future water user groups from accessing these water supplies. For example, City B relies on a river that can provide 500 acre-feet per year during drought of record conditions and other constraints as dictated by planning assumptions. In 2010, the city is expected to use an estimated 100 acre-feet per year and by 2060 it would require no more than 400 acre-feet. But the intake and pipeline that currently transfers water from the river to the city's treatment plant has a capacity of only 200 acre-feet of water per year. Thus, the city's water supplies are adequate even under the most restrictive planning assumptions, but their conveyance system is too small. This implies that at some point – perhaps around 2030 - infrastructure limitations would constrain future population growth and any associated economic activity or impacts.
- 3) Scenario 3 involves water user groups that rely primarily on aquifers that are being depleted. In this scenario, projected and in some cases existing demands may be unsustainable as groundwater levels decline. Areas that rely on the Ogallala aquifer are a good example. In some communities in the region, irrigated agriculture forms a major base of the regional economy. With less irrigation water from the Ogallala, population and economic activity in the region could decline significantly assuming there are no offsetting developments.

Assessing the social and economic effects of each of the above scenarios requires various levels and methods of analysis and would generate substantially different results for a number of reasons; the most important of which has to do with the time frame of each scenario. Scenario 1 falls into the general category of static analysis. This means that models would measure impacts for a small interval of time such as a drought. Scenarios 2 and 3, on the other hand imply a dynamic analysis meaning that models are concerned with changes over a much longer time period.

Since administrative rules specify that planning analysis be evaluated under drought of record conditions (a static and random event), socioeconomic impact analysis developed by the TWDB for the state water plan is based on assumptions of Scenario 1. Estimated impacts under scenario 1 are point estimates for years in which needs are reported (2010, 2020, 2030, 2040, 2050 and 2060). They are independent and distinct "what if" scenarios for a particular year and shortages are assumed to be temporary events resulting from drought of record conditions. Estimated impacts measure what would happen if water user groups experience water shortages for a period of one year.

The TWDB recognize that dynamic models may be more appropriate for some water user groups; however, combining approaches on a statewide basis poses several problems. For one, it would require a complex array of analyses and models, and might require developing supply and demand forecasts under "normal" climatic conditions as opposed to drought of record conditions. Equally important is the notion that combining the approaches would produce inconsistent results across regions resulting in a so-called "apples to oranges" comparison.

A variety of tools are available to estimate economic impacts, but by far, the most widely used today are input-output models (IO models) combined with social accounting matrices (SAMs). Referred to as IO/SAM models, these tools formed the basis for estimating economic impacts for agriculture (irrigation and livestock water uses) and industry (manufacturing, mining, steam-electric and commercial business activity for municipal water uses).

Since the planning horizon extends through 2060, economic variables in the baseline are adjusted in accordance with projected changes in demographic and economic activity. Growth rates for municipal water use sectors (i.e., commercial, residential and institutional) are based on TWDB population forecasts. Future values for manufacturing, agriculture, and mining and steam-electric activity are based on the same underlying economic forecasts used to estimate future water use for each category.

The following steps outline the overall process.

Step 1: Generate IO/SAM Models and Develop Economic Baseline

IO/SAM models were estimated using propriety software known as IMPLAN PROTM (Impact for Planning Analysis). IMPLAN is a modeling system originally developed by the U.S. Forestry Service in the late 1970s. Today, the Minnesota IMPLAN Group (MIG Inc.) owns the copyright and distributes data and software. It is probably the most widely used economic impact model in existence. IMPLAN comes with databases containing the most recently available economic data from a variety of sources.¹ Using IMPLAN software and data, transaction tables conceptually similar to the one discussed previously were estimated for each county in the region and for the region as a whole. Each transaction table contains 528 economic sectors and allows one to estimate a variety of economic statistics including:

- **total sales** - total production measured by sales revenues;
- **intermediate sales** - sales to other businesses and industries within a given region;
- **final sales** – sales to end users in a region and exports out of a region;
- **employment** - number of full and part-time jobs (annual average) required by a given industry including self-employment;
- **regional income** - total payroll costs (wages and salaries plus benefits) paid by industries, corporate income, rental income and interest payments; and
- **business taxes** - sales, excise, fees, licenses and other taxes paid during normal operation of an industry (does not include income taxes).

TWDB analysts developed an economic baseline containing each of the above variables using year 2000 data. Since the planning horizon extends through 2060, economic variables in the baseline were allowed to change in accordance with projected changes in demographic and economic activity. Growth rates for municipal water use sectors (i.e., commercial, residential and institutional) are based on TWDB population forecasts. Projections for manufacturing, agriculture, and mining and steam-electric activity are based on the same underlying economic forecasts used to estimate future water use for each category. Monetary impacts in future years are reported in constant year 2006 dollars.

It is important to stress that employment, income and business taxes are the most useful variables when comparing the relative contribution of an economic sector to a regional economy. Total sales as reported in IO/SAM models are less desirable and can be misleading because they include sales to other industries in the region for use in the production of other goods. For example, if a mill buys grain from local farmers and uses it to produce feed, sales of both the processed feed and raw corn are counted

¹The IMPLAN database consists of national level technology matrices based on benchmark input-output accounts generated by the U.S. Bureau of Economic Analysis and estimates of final demand, final payments, industry output and employment for various economic sectors. IMPLAN regional data (i.e. states, a counties or groups of counties within a state) are divided into two basic categories: 1) data on an industry basis including value-added, output and employment, and 2) data on a commodity basis including final demands and institutional sales. State-level data are balanced to national totals using a matrix ratio allocation system and county data are balanced to state totals.

as “output” in an IO model. Thus, total sales double-count or overstate the true economic value of goods and services produced in an economy. They are not consistent with commonly used measures of output such as Gross National Product (GNP), which counts only final sales.

Another important distinction relates to terminology. Throughout this report, the term *sector* refers to economic subdivisions used in the IMPLAN database and resultant input-output models (528 individual sectors based on Standard Industrial Classification Codes). In contrast, the phrase *water use category* refers to water user groups employed in state and regional water planning including irrigation, livestock, mining, municipal, manufacturing and steam electric. Each IMPLAN sector was assigned to a specific water use category.

Step 2: Estimate Direct and Indirect Economic Impacts of Water Needs

Direct impacts are reductions in output by sectors experiencing water shortages. For example, without adequate cooling and process water a refinery would have to curtail or cease operation, car washes may close, or farmers may not be able to irrigate and sales revenues fall. Indirect impacts involve changes in inter-industry transactions as supplying industries respond to decreased demands for their services, and how seemingly non-related businesses are affected by decreased incomes and spending due to direct impacts. For example, if a farmer ceases operations due to a lack of irrigation water, they would likely reduce expenditures on supplies such as fertilizer, labor and equipment, and businesses that provide these goods would suffer as well.

Direct impacts accrue to immediate businesses and industries that rely on water and without water industrial processes could suffer. However, output responses may vary depending upon the severity of shortages. A small shortage relative to total water use would likely have a minimal impact, but large shortages could be critical. For example, farmers facing small shortages might fallow marginally productive acreage to save water for more valuable crops. Livestock producers might employ emergency culling strategies, or they may consider hauling water by truck to fill stock tanks. In the case of manufacturing, a good example occurred in the summer of 1999 when Toyota Motor Manufacturing experienced water shortages at a facility near Georgetown, Kentucky.² As water levels in the Kentucky River fell to historic lows due to drought, plant managers sought ways to curtail water use such as reducing rinse operations to a bare minimum and recycling water by funneling it from paint shops to boilers. They even considered trucking in water at a cost of 10 times what they were paying. Fortunately, rains at the end of the summer restored river levels, and Toyota managed to implement cutbacks without affecting production, but it was a close call. If rains had not replenished the river, shortages could have severely reduced output.³

To account for uncertainty regarding the relative magnitude of impacts to farm and business operations, the following analysis employs the concept of elasticity. Elasticity is a number that shows how a change in one variable will affect another. In this case, it measures the relationship between a percentage reduction in water availability and a percentage reduction in output. For example, an elasticity of 1.0 indicates that a 1.0 percent reduction in water availability would result in a 1.0 percent reduction in

² Royal, W. “High And Dry - Industrial Centers Face Water Shortages.” in *Industry Week*, Sept, 2000.

³ The efforts described above are not planned programmatic or long-term operational changes. They are emergency measures that individuals might pursue to alleviate what they consider a temporary condition. Thus, they are not characteristic of long-term management strategies designed to ensure more dependable water supplies such as capital investments in conservation technology or development of new water supplies.

economic output. An elasticity of 0.50 would indicate that for every 1.0 percent of unavailable water, output is reduced by 0.50 percent and so on. Output elasticities used in this study are:⁴

- if water needs are 0 to 5 percent of total water demand, no corresponding reduction in output is assumed;
- if water needs are 5 to 30 percent of total water demand, for each additional one percent of water need that is not met, there is a corresponding 0.50 percent reduction in output;
- if water needs are 30 to 50 percent of total water demand, for each additional one percent of water need that is not met, there is a corresponding 0.75 percent reduction in output; and
- if water needs are greater than 50 percent of total water demand, for each additional one percent of water need that is not met, there is a corresponding 1.0 percent (i.e., a proportional reduction).

In some cases, elasticities are adjusted depending upon conditions specific to a given water user group.

Once output responses to water shortages were estimated, direct impacts to total sales, employment, regional income and business taxes were derived using regional level economic multipliers estimating using IO/SAM models. The formula for a given IMPLAN sector is:

$$D_{i,t} = Q_{i,t} * S_{i,t} * E_Q * RFD_i * DM_{i(Q,L,I,T)}$$

where:

$D_{i,t}$ = direct economic impact to sector i in period t

$Q_{i,t}$ = total sales for sector i in period t in an affected county

RFD_i = ratio of final demand to total sales for sector i for a given region

$S_{i,t}$ = water shortage as percentage of total water use in period t

E_Q = elasticity of output and water use

$DM_{i(Q,L,I,T)}$ = direct output multiplier coefficients for labor (L), income (I) and taxes (T) for sector i .

Secondary impacts were derived using the same formula used to estimate direct impacts; however, indirect multiplier coefficients are used. Methods and assumptions specific to each water use sector are discussed in Sections 1.1.2 through 1.1.4.

⁴ Elasticities are based on one of the few empirical studies that analyze potential relationships between economic output and water shortages in the United States. The study, conducted in California, showed that a significant number of industries would suffer reduced output during water shortages. Using a survey based approach researchers posed two scenarios to different industries. In the first scenario, they asked how a 15 percent cutback in water supply lasting one year would affect operations. In the second scenario, they asked how a 30 percent reduction lasting one year would affect plant operations. In the case of a 15 percent shortage, reported output elasticities ranged from 0.00 to 0.76 with an average value of 0.25. For a 30 percent shortage, elasticities ranged from 0.00 to 1.39 with average of 0.47. For further information, see, California Urban Water Agencies, "Cost of Industrial Water Shortages," Spectrum Economics, Inc. November, 1991.

General Assumptions and Clarification of the Methodology

As with any attempt to measure and quantify human activities at a societal level, assumptions are necessary and every model has limitations. Assumptions are needed to maintain a level of generality and simplicity such that models can be applied on several geographic levels and across different economic sectors. In terms of the general approach used here several clarifications and cautions are warranted:

1. Shortages as reported by regional planning groups are the starting point for socioeconomic analyses.
2. Estimated impacts are point estimates for years in which needs are reported (i.e., 2010, 2020, 2030, 2040, 2050 and 2060). They are independent and distinct “what if” scenarios for each particular year and water shortages are assumed to be temporary events resulting from severe drought conditions combined with infrastructure limitations. In other words, growth occurs and future shocks are imposed on an economy at 10-year intervals and resultant impacts are measured. Given that reported figures are not cumulative in nature, it is inappropriate to sum impacts over the entire planning horizon. Doing so, would imply that the analysis predicts that drought of record conditions will occur every ten years in the future, which is not the case. Similarly, authors of this report recognize that in many communities needs are driven by population growth, and in the future total population will exceed the amount of water available due to infrastructure limitations, regardless of whether or not there is a drought. This implies that infrastructure limitations would constrain economic growth. However, since needs as defined by planning rules are based upon water supply and demand under the assumption of drought of record conditions, it is improper to conduct economic analysis that focuses on growth related impacts over the planning horizon. Figures generated from such an analysis would presume a 50-year drought of record, which is unrealistic. Estimating lost economic activity related to constraints on population and commercial growth due to lack of water would require developing water supply and demand forecasts under “normal” or “most likely” future climatic conditions.
3. While useful for planning purposes, this study is not a benefit-cost analysis. Benefit cost analysis is a tool widely used to evaluate the economic feasibility of specific policies or projects as opposed to estimating economic impacts of unmet water needs. Nevertheless, one could include some impacts measured in this study as part of a benefit cost study if done so properly. Since this is not a benefit cost analysis, future impacts are not weighted differently. In other words, estimates are not discounted. If used as a measure of economic benefits, one should incorporate a measure of uncertainty into the analysis. In this type of analysis, a typical method of discounting future values is to assign probabilities of the drought of record recurring again in a given year, and weight monetary impacts accordingly. This analysis assumes a probability of one.
4. IO multipliers measure the strength of backward linkages to supporting industries (i.e., those who sell inputs to an affected sector). However, multipliers say nothing about forward linkages consisting of businesses that purchase goods from an affected sector for further processing. For example, ranchers in many areas sell most of their animals to local meat packers who process animals into a form that consumers ultimately see in grocery stores and restaurants. Multipliers do not capture forward linkages to meat packers, and since meat packers sell livestock purchased from ranchers as “final sales,” multipliers for the ranching sector do not fully account for all losses to a region’s economy. Thus, as mentioned previously, in some cases closely linked sectors were moved from one water use category to another.
5. Cautions regarding interpretations of direct and secondary impacts are warranted. IO/SAM multipliers are based on “fixed-proportion production functions,” which basically means that input use - including labor - moves in lockstep fashion with changes in levels of output. In a

scenario where output (i.e., sales) declines, losses in the immediate sector or supporting sectors could be much less than predicted by an IO/SAM model for several reasons. For one, businesses will likely expect to continue operating so they might maintain spending on inputs for future use; or they may be under contractual obligations to purchase inputs for an extended period regardless of external conditions. Also, employers may not lay-off workers given that experienced labor is sometimes scarce and skilled personnel may not be readily available when water shortages subside. Lastly people who lose jobs might find other employment in the region. As a result, direct losses for employment and secondary losses in sales and employment should be considered an upper bound. Similarly, since projected population losses are based on reduced employment in the region, they should be considered an upper bound as well.

6. IO models are static. Models and resultant multipliers are based upon the structure of the U.S. and regional economies in 2006. In contrast, water shortages are projected to occur well into the future. Thus, the analysis assumes that the general structure of the economy remains the same over the planning horizon, and the farther out into the future we go, this assumption becomes less reliable.
7. Impacts are annual estimates. If one were to assume that conditions persisted for more than one year, figures should be adjusted to reflect the extended duration. The drought of record in most regions of Texas lasted several years.
8. Monetary figures are reported in constant year 2006 dollars.

1.1.2 Impacts to Agriculture

Irrigated Crop Production

The first step in estimating impacts to irrigation required calculating gross sales for IMPLAN crop sectors. Default IMPLAN data do not distinguish irrigated production from dry-land production. Once gross sales were known other statistics such as employment and income were derived using IMPLAN direct multiplier coefficients. Gross sales for a given crop are based on two data sources:

- 1) county-level statistics collected and maintained by the TWDB and the USDA Farm Services Agency (FSA) including the number of irrigated acres by crop type and water application per acre, and
- 2) regional-level data published by the Texas Agricultural Statistics Service (TASS) including prices received for crops (marketing year averages), crop yields and crop acreages.

Crop categories used by the TWDB differ from those used in IMPLAN datasets. To maintain consistency, sales and other statistics are reported using IMPLAN crop classifications. Table 1 shows the TWDB crops included in corresponding IMPLAN sectors, and Table 2 summarizes acreage and estimated annual water use for each crop classification (five-year average from 2003-2007). Table 3 displays average (2003-2007) gross revenues per acre for IMPLAN crop categories.

Table 1: Crop Classifications Used in TWDB Water Use Survey and Corresponding IMPLAN Crop Sectors	
IMPLAN Category	TWDB Category
Oilseeds	Soybeans and "other oil crops"
Grains	Grain sorghum, corn, wheat and "other grain crops"
Vegetable and melons	"Vegetables" and potatoes
Tree nuts	Pecans
Fruits	Citrus, vineyard and other orchard
Cotton	Cotton
Sugarcane and sugar beets	Sugarcane and sugar beets
All "other" crops	"Forage crops", peanuts, alfalfa, hay and pasture, rice and "all other crops"

Table 2: Summary of Irrigated Crop Acreage and Water Demand for the South Central Texas Regional Water Planning Area (average 2003-2007)				
Sector	Acre (1000s)	Distribution of acres	Water use (1000s of AF)	Distribution of water use
Oilseeds	2	1%	2	1%
Grains	108	43%	123	38%
Vegetable and melons	34	14%	39	12%
Tree nuts	3	1%	7	2%
Fruits	<1	<1%	<1	<1%
Cotton	32	13%	45	14%
All "other" crops	70	28%	105	33%
Total	251	100%	321	100%

Source: Water demand figures are a 5- year average (2003-2007) of the TWDB's annual Irrigation Water Use Estimates. Statistics for irrigated crop acreage are based upon annual survey data collected by the TWDB and the Farm Service Agency. Values do not include acreage or water use for the TWDB categories classified by the Farm Services Agency as "failed acres," "golf course" or "waste water."

Table 3: Average Gross Sales Revenues per Acre for Irrigated Crops for the South Central Texas Regional Water Planning Area (2003-2007)

IMPLAN Sector	Gross revenues per acre	Crops included in estimates
Oilseeds	\$178	Based on five-year (2003-2007) average weighted by acreage for "irrigated soybeans" and "irrigated 'other' oil crops."
Grains	\$235	Based on five-year (2003-2007) average weighted by acreage for "irrigated grain sorghum", "irrigated corn", "irrigated wheat" and "irrigated 'other' grain crops."
Vegetable and melons	\$5,725	Based on five-year (2003-2007) average weighted by acreage for "irrigated shallow and deep root vegetables", "irrigated Irish potatoes" and "irrigated melons."
Tree nuts	\$3,374	Based on five-year (2003-2007) average weighted by acreage for "irrigated pecans."
Fruits	\$26,423	Based on five-year (2003-2007) average weighted by acreage for "irrigated citrus", "irrigated vineyards" and "irrigated 'other' orchard."
Cotton	\$543	Based on five-year (2003-2007) average weighted by acreage for "irrigated cotton."
All "other" crops	\$359	Based on five-year (2003-2007) average weighted by acreage for "irrigated 'forage' crops", "irrigated peanuts", "irrigated alfalfa", "irrigated 'hay' and pasture" and "irrigated 'all other' crops."

*Figures are rounded. Source: Based on data from the Texas Agricultural Statistics Service, Texas Water Development Board, and Texas A&M University.

An important consideration when estimating impacts to irrigation was determining which crops are affected by water shortages. One approach is the so-called rationing model, which assumes that farmers respond to water supply cutbacks by following the lowest value crops in the region first and the highest valued crops last until the amount of water saved equals the shortage.⁵ For example, if farmer A grows vegetables (higher value) and farmer B grows wheat (lower value) and they both face a proportionate cutback in irrigation water, then farmer B will sell water to farmer A. Farmer B will follow her irrigated acreage before farmer A follows anything. Of course, this assumes that farmers can and do transfer enough water to allow this to happen. A different approach involves constructing farm-level profit maximization models that conform to widely-accepted economic theory that farmers make decisions based on marginal net returns. Such models have good predictive capability, but data requirements and complexity are high. Given that a detailed analysis for each region would require a substantial amount of farm-level data and analysis, the following investigation assumes that projected shortages are distributed equally across predominant crops in the region. Predominant in this case are crops that comprise at least one percent of total acreage in the region.

The following steps outline the overall process used to estimate direct impacts to irrigated agriculture:

1. *Distribute shortages across predominant crop types in the region.* Again, unmet water needs were distributed equally across crop sectors that constitute one percent or more of irrigated acreage.
2. *Estimate associated reductions in output for affected crop sectors.* Output reductions are based on elasticities discussed previously and on estimated values per acre for different crops. Values per acre stem from the same data used to estimate output for the year 2006 baseline. Using multipliers, we then generate estimates of forgone income, jobs, and tax revenues based on reductions in gross sales and final demand.

Livestock

The approach used for the livestock sector is basically the same as that used for crop production. As is the case with crops, livestock categorizations used by the TWDB differ from those used in IMPLAN datasets, and TWDB groupings were assigned to a given IMPLAN sector (Table 4). Then we:

- 1) *Distribute projected water needs equally among predominant livestock sectors and estimate lost output:* As is the case with irrigation, shortages are assumed to affect all livestock sectors equally; however, the category of “other” is not included given its small size. If water needs were small relative to total demands, we assume that producers would haul in water by truck to fill stock tanks. The cost per acre-foot (\$24,000) is based on 2008 rates charged by various water haulers in Texas, and assumes that the average truck load is 6,500 gallons at a hauling distance of 60 miles.
- 3) *Estimate reduced output in forward processors for livestock sectors.* Reductions in output for livestock sectors are assumed to have a proportional impact on forward processors in the region such as meat packers. In other words, if the cows were gone, meat-packing plants or fluid milk manufacturers) would likely have little to process. This is not an unreasonable premise. Since the

⁵ The rationing model was initially proposed by researchers at the University of California at Berkeley, and was then modified for use in a study conducted by the U.S. Environmental Protection Agency that evaluated how proposed water supply cutbacks recommended to protect water quality in the Bay/Delta complex in California would affect farmers in the Central Valley. See, Zilberman, D., Howitt, R. and Sunding, D. “*Economic Impacts of Water Quality Regulations in the San Francisco Bay and Delta.*” Western Consortium for Public Health. May 1993.

1950s, there has been a major trend towards specialized cattle feedlots, which in turn has decentralized cattle purchasing from livestock terminal markets to direct sales between producers and slaughterhouses. Today, the meat packing industry often operates large processing facilities near high concentrations of feedlots to increase capacity utilization.⁶ As a result, packers are heavily dependent upon nearby feedlots. For example, a recent study by the USDA shows that on average meat packers obtain 64 percent of cattle from within 75 miles of their plant, 82 percent from within 150 miles and 92 percent from within 250 miles.⁷

Table 4: Description of Livestock Sectors	
IMPLAN Category	TWDB Category
Cattle ranching and farming	Cattle, cow calf, feedlots and dairies
Poultry and egg production	Poultry production.
Other livestock	Livestock other than cattle and poultry (i.e., horses, goats, sheep, hogs)
Milk manufacturing	Fluid milk manufacturing, cheese manufacturing, ice cream manufacturing etc.
Meat packing	Meat processing present in the region from slaughter to final processing

1.1.3 Impacts to Municipal Water User Groups

Disaggregation of Municipal Water Demands

Estimating the economic impacts for the municipal water user groups is complicated for a number of reasons. For one, municipal use comprises a range of consumers including commercial businesses, institutions such as schools and government and households. However, reported water needs are not distributed among different municipal water users. In other words, how much of a municipal need is commercial and how much is residential (domestic)?

The amount of commercial water use as a percentage of total municipal demand was estimated based on “GED” coefficients (gallons per employee per day) published in secondary sources.⁸ For example, if year 2006 baseline data for a given economic sector (e.g., amusement and recreation services) shows employment at 30 jobs and the GED coefficient is 200, then average daily water use by that sector

⁶ Ferreira, W.N. “Analysis of the Meat Processing Industry in the United States.” Clemson University Extension Economics Report ER211, January 2003.

⁷ Ward, C.E. “Summary of Results from USDA’s Meatpacking Concentration Study.” Oklahoma Cooperative Extension Service, OSU Extension Facts WF-562.

⁸ Sources for GED coefficients include: Gleick, P.H., Haasz, D., Henges-Jeck, C., Srinivasan, V., Wolff, G. Cushing, K.K., and Mann, A. “Waste Not, Want Not: The Potential for Urban Water Conservation in California.” Pacific Institute. November 2003. U.S. Bureau of the Census. 1982 Census of Manufacturers: Water Use in Manufacturing. USGPO, Washington D.C. See also: “U.S. Army Engineer Institute for Water Resources, IWR Report 88-R-6,” Fort Belvoir, VA. See also, Joseph, E. S., 1982, “Municipal and Industrial Water Demands of the Western United States.” Journal of the Water Resources Planning and Management Division, Proceedings of the American Society of Civil Engineers, v. 108, no. WR2, p. 204-216. See also, Baumann, D. D., Boland, J. J., and Sims, J. H., 1981, “Evaluation of Water Conservation for Municipal and Industrial Water Supply.” U.S. Army Corps of Engineers, Institute for Water Resources, Contract no. 82-C1.

is (30 x 200 = 6,000 gallons) or 6.7 acre-feet per year. Water not attributed to commercial use is considered domestic, which includes single and multi-family residential consumption, institutional uses and all use designated as “county-other.” Based on our analysis, commercial water use is about 5 to 35 percent of municipal demand. Less populated rural counties occupy the lower end of the spectrum, while larger metropolitan counties are at the higher end.

After determining the distribution of domestic versus commercial water use, we developed methods for estimating impacts to the two groups.

Domestic Water Uses

Input output models are not well suited for measuring impacts of shortages for domestic water uses, which make up the majority of the municipal water use category. To estimate impacts associated with domestic water uses, municipal water demand and needs are subdivided into residential, and commercial and institutional use. Shortages associated with residential water uses are valued by estimating proxy demand functions for different water user groups allowing us to estimate the marginal value of water, which would vary depending upon the level of water shortages. The more severe the water shortage, the more costly it becomes. For instance, a 2 acre-foot shortage for a group of households that use 10 acre-feet per year would not be as severe as a shortage that amounted to 8 acre-feet. In the case of a 2 acre-foot shortage, households would probably have to eliminate some or all outdoor water use, which could have implicit and explicit economic costs including losses to the horticultural and landscaping industry. In the case of an 8 acre-foot shortage, people would have to forgo all outdoor water use and most indoor water consumption. Economic impacts would be much higher in the latter case because people, and would be forced to find emergency alternatives assuming alternatives were available.

To estimate the value of domestic water uses, TWDB staff developed marginal loss functions based on constant elasticity demand curves. This is a standard and well-established method used by economists to value resources such as water that have an explicit monetary cost.

A constant price elasticity of demand is estimated using a standard equation:

$$w = kc^{(-\epsilon)}$$

where:

- w is equal to average monthly residential water use for a given water user group measured in thousands of gallons;
- k is a constant intercept;
- c is the average cost of water per 1,000 gallons; and
- ϵ is the price elasticity of demand.

Price elasticities (-0.30 for indoor water use and -0.50 for outdoor use) are based on a study by Bell et al.⁹ that surveyed 1,400 water utilities in Texas that serve at least 1,000 people to estimate demand elasticity for several variables including price, income, weather etc. Costs of water and average use per month per household are based on data from the Texas Municipal League's annual water and

⁹ Bell, D.R. and Griffin, R.C. “Community Water Demand in Texas as a Century is Turned.” Research contract report prepared for the Texas Water Development Board. May 2006.

wastewater rate surveys - specifically average monthly household expenditures on water and wastewater in different communities across the state. After examining variance in costs and usage, three different categories of water user groups based on population (population less than 5,000, cities with populations ranging from 5,000 to 99,999 and cities with populations exceeding 100,000) were selected to serve as proxy values for municipal water groups that meet the criteria (Table 5).¹⁰

Table 5: Water Use and Costs Parameters Used to Estimated Water Demand Functions (average monthly costs per acre-foot for delivered water and average monthly use per household)				
Community Population	Water	Wastewater	Total monthly cost	Avg. monthly use (gallons)
Less than or equal to 5,000	\$1,335	\$1,228	\$2,563	6,204
5,000 to 100,000	\$1,047	\$1,162	\$2,209	7,950
Great than or equal to 100,000	\$718	\$457	\$1,190	8,409

Source: Based on annual water and wastewater rate surveys published by the Texas Municipal League.

As an example, Table 6 shows the economic impact per acre-foot of domestic water needs for municipal water user groups with population exceeding 100,000 people. There are several important assumptions incorporated in the calculations:

- 1) Reported values are net of the variable costs of treatment and distribution such as expenses for chemicals and electricity since using less water involves some savings to consumers and utilities alike; and for outdoor uses we do not include any value for wastewater.
- 2) Outdoor and “non-essential” water uses would be eliminated before indoor water consumption was affected, which is logical because most water utilities in Texas have drought contingency plans that generally specify curtailment or elimination of outdoor water use during droughts.¹¹ Determining how much water is used for outdoor purposes is based on several secondary sources. The first is a major study sponsored by the American Water Works Association, which surveyed cities in states including Colorado, Oregon, Washington, California, Florida and Arizona. On average across all cities surveyed 58 percent of single family residential water use was for outdoor activities. In cities with climates comparable to large metropolitan areas of Texas, the average was 40 percent.¹² Earlier findings of the U.S. Water Resources Council showed a

¹⁰ Ideally, one would want to estimate demand functions for each individual utility in the state. However, this would require an enormous amount of time and resources. For planning purposes, we believe the values generated from aggregate data are more than sufficient.

¹¹ In Texas, state law requires retail and wholesale water providers to prepare and submit plans to the Texas Commission on Environmental Quality (TCEQ). Plans must specify demand management measures for use during drought including curtailment of “non-essential water uses.” Non-essential uses include, but are not limited to, landscape irrigation and water for swimming pools or fountains. For further information see the Texas Environmental Quality Code §288.20.

¹² See, Mayer, P.W., DeOreo, W.B., Opitz, E.M., Kiefer, J.C., Davis, W., Dziegielewski, D., Nelson, J.O. “Residential End Uses of Water.” Research sponsored by the American Water Works Association and completed by Aquacraft, Inc. and Planning and Management Consultants, Ltd. (PMCL@CDM).

national average of 33 percent. Similarly, the United States Environmental Protection Agency (USEPA) estimated that landscape watering accounts for 32 percent of total residential and commercial water use on annual basis.¹³ A study conducted for the California Urban Water Agencies (CUWA) calculated average annual values ranging from 25 to 35 percent.¹⁴ Unfortunately, there does not appear to be any comprehensive research that has estimated non-agricultural outdoor water use in Texas. As an approximation, an average annual value of 30 percent based on the above references was selected to serve as a rough estimate in this study.

3) As shortages approach 100 percent values become immense and theoretically infinite at 100 percent because at that point death would result, and willingness to pay for water is immeasurable. Thus, as shortages approach 80 percent of monthly consumption, we assume that households and non-water intensive commercial businesses (those that use water only for drinking and sanitation would have water delivered by tanker truck or commercial water delivery companies. Based on reports from water companies throughout the state, we estimate that the cost of trucking in water is around \$21,000 to \$27,000 per acre-feet assuming a hauling distance of between 20 to 60 miles. This is not an unreasonable assumption. The practice was widespread during the 1950s drought and recently during droughts in this decade. For example, in 2000 at the heels of three consecutive drought years Electra - a small town in North Texas - was down to its last 45 days worth of reservoir water when rain replenished the lake, and the city was able to refurbish old wells to provide supplemental groundwater. At the time, residents were forced to limit water use to 1,000 gallons per person per month - less than half of what most people use - and many were having water delivered to their homes by private contractors.¹⁵ In 2003 citizens of Ballinger, Texas, were also faced with a dwindling water supply due to prolonged drought. After three years of drought, Lake Ballinger, which supplies water to more than 4,300 residents in Ballinger and to 600 residents in nearby Rowena, was almost dry. Each day, people lined up to get water from a well in nearby City Park. Trucks hauling trailers outfitted with large plastic and metal tanks hauled water to and from City Park to Ballinger.¹⁶

¹³ U.S. Environmental Protection Agency. *"Cleaner Water through Conservation."* USEPA Report no. 841-B-95-002. April, 1995.

¹⁴ Planning and Management Consultants, Ltd. *"Evaluating Urban Water Conservation Programs: A Procedures Manual."* Prepared for the California Urban Water Agencies. February 1992.

¹⁵ Zewe, C. *"Tap Threatens to Run Dry in Texas Town."* July 11, 2000. CNN Cable News Network.

¹⁶ Associated Press, *"Ballinger Scrambles to Finish Pipeline before Lake Dries Up."* May 19, 2003.

Table 6: Economic Losses Associated with Domestic Water Shortages in Communities with Populations Exceeding 100,000 people

Water shortages as a percentage of total monthly household demands	No. of gallons remaining per household per day	No of gallons remaining per person per day	Economic loss (per acre-foot)	Economic loss (per gallon)
1%	278	93	\$748	\$0.00005
5%	266	89	\$812	\$0.0002
10%	252	84	\$900	\$0.0005
15%	238	79	\$999	\$0.0008
20%	224	75	\$1,110	\$0.0012
25%	210	70	\$1,235	\$0.0015
30% ^a	196	65	\$1,699	\$0.0020
35%	182	61	\$3,825	\$0.0085
40%	168	56	\$4,181	\$0.0096
45%	154	51	\$4,603	\$0.011
50%	140	47	\$5,109	\$0.012
55%	126	42	\$5,727	\$0.014
60%	112	37	\$6,500	\$0.017
65%	98	33	\$7,493	\$0.02
70%	84	28	\$8,818	\$0.02
75%	70	23	\$10,672	\$0.03
80%	56	19	\$13,454	\$0.04
85%	42	14	\$18,091 (\$24,000) ^b	\$0.05 (\$0.07) ^b
90%	28	9	\$27,363 (\$24,000)	\$0.08 (\$0.07)
95%	14	5	\$55,182 (\$24,000)	\$0.17 (\$0.07)
99%	3	0.9	\$277,728 (\$24,000)	\$0.85 (\$0.07)
99.9%	1	0.5	\$2,781,377 (\$24,000)	\$8.53 (\$0.07)
100%	0	0	Infinite (\$24,000)	Infinite (\$0.07)

^a The first 30 percent of needs are assumed to be restrictions of outdoor water use; when needs reach 30 percent of total demands all outdoor water uses would be restricted. Needs greater than 30 percent include indoor use

^b As shortages approach 100 percent the value approaches infinity assuming there are not alternatives available; however, we assume that communities would begin to have water delivered by tanker truck at an estimated cost of \$24,000 per acre-foot when shortages breached 85 percent.

Commercial Businesses

Effects of water shortages on commercial sectors were estimated in a fashion similar to other business sectors meaning that water shortages would affect the ability of these businesses to operate. This is particularly true for “water intensive” commercial sectors that need large amounts of water (in addition to potable and sanitary water) to provide their services. These include:

- car-washes,
- laundry and cleaning facilities,
- sports and recreation clubs and facilities including race tracks,
- amusement and recreation services,
- hospitals and medical facilities,
- hotels and lodging places, and
- eating and drinking establishments.

A key assumption is that commercial operations would not be affected until water shortages were at least 50 percent of total municipal demand. In other words, we assume that residential water consumers would reduce water use including all non-essential uses before businesses were affected.

An example will illustrate the breakdown of municipal water needs and the overall approach to estimating impacts of municipal needs. Assume City A experiences an unexpected shortage of 50 acre-feet per year when their demands are 200 acre-feet per year. Thus, shortages are only 25 percent of total municipal use and residents of City A could eliminate needs by restricting landscape irrigation. City B, on the other hand, has a deficit of 150 acre-feet in 2020 and a projected demand of 200 acre-feet. Thus, total shortages are 75 percent of total demand. Emergency outdoor and some indoor conservation measures could eliminate 50 acre-feet of projected needs, yet 50 acre-feet would still remain. To eliminate” the remaining 50 acre-feet water intensive commercial businesses would have to curtail operations or shut down completely.

Three other areas were considered when analyzing municipal water shortages: 1) lost revenues to water utilities, 2) losses to the horticultural and landscaping industries stemming from reduction in water available for landscape irrigation, and 3) lost revenues and related economic impacts associated with reduced water related recreation.

Water Utility Revenues

Estimating lost water utility revenues was straightforward. We relied on annual data from the “*Water and Wastewater Rate Survey*” published annually by the Texas Municipal League to calculate an average value per acre-foot for water and sewer. For water revenues, average retail water and sewer rates multiplied by total water needs served as a proxy. For lost wastewater, total unmet needs were adjusted for return flow factor of 0.60 and multiplied by average sewer rates for the region. Needs reported as “county-other” were excluded under the presumption that these consist primarily of self-supplied water uses. In addition, 15 percent of water demand and needs are considered non-billed or “unaccountable” water that comprises things such as leakages and water for municipal government functions (e.g., fire departments). Lost tax receipts are based on current rates for the “miscellaneous gross receipts tax,” which the state collects from utilities located in most incorporated cities or towns in Texas. We do not include lost water utility revenues when aggregating impacts of municipal water shortages to regional and state levels to prevent double counting.

Horticultural and Landscaping Industry

The horticultural and landscaping industry, also referred to as the “green Industry,” consists of businesses that produce, distribute and provide services associated with ornamental plants, landscape and garden supplies and equipment. Horticultural industries often face big losses during drought. For example, the recent drought in the Southeast affecting the Carolinas and Georgia horticultural and landscaping businesses had a harsh year. Plant sales were down, plant mortality increased, and watering costs increased. Many businesses were forced to close locations, lay off employees, and even file for bankruptcy. University of Georgia economists put statewide losses for the industry at around \$3.2 billion during the 3-year drought that ended in 2008.¹⁷ Municipal restrictions on outdoor watering play a significant role. During drought, water restrictions coupled with persistent heat has a psychological effect on homeowners that reduces demands for landscaping products and services. Simply put, people were afraid to spend any money on new plants and landscaping.

In Texas, there do not appear to be readily available studies that analyze the economic effects of water shortages on the industry. However, authors of this report believe negative impacts do and would result in restricting landscape irrigation to municipal water consumers. The difficulty in measuring them is two-fold. First, as noted above, data and research for these types of impacts that focus on Texas are limited; and second, economic data provided by IMPLAN do not disaggregate different sectors of the green industry to a level that would allow for meaningful and defensible analysis.¹⁸

Recreational Impacts

Recreational businesses often suffer when water levels and flows in rivers, springs and reservoirs fall significantly during drought. During droughts, many boat docks and lake beaches are forced to close, leading to big losses for lakeside business owners and local communities. Communities adjacent to popular river and stream destinations such as Comal Springs and the Guadalupe River also see their business plummet when springs and rivers dry up. Although there are many examples of businesses that have suffered due to drought, dollar figures for drought-related losses to the recreation and tourism industry are not readily available, and very difficult to measure without extensive local surveys. Thus, while they are important, economic impacts are not measured in this study.

Table 7 summarizes impacts of municipal water shortages at differing levels of magnitude, and shows the ranges of economic costs or losses per acre-foot of shortage for each level.

¹⁷ Williams, D. “Georgia landscapers eye rebound from Southeast drought.” Atlanta Business Chronicle, Friday, June 19, 2009

¹⁸ Economic impact analyses prepared by the TWDB for 2006 regional water plans did include estimates for the horticultural industry. However, year 2000 and prior IMPLAN data were disaggregated to a finer level. In the current dataset (2006), the sector previously listed as “Landscaping and Horticultural Services” (IMPLAN Sector 27) is aggregated into “Services to Buildings and Dwellings” (IMPLAN Sector 458).

Table 7: Impacts of Municipal Water Shortages at Different Magnitudes of Shortages		
Water shortages as percent of total municipal demands	Impacts	Economic costs per acre-foot*
0-30%	<ul style="list-style-type: none"> ✓ Lost water utility revenues ✓ Restricted landscape irrigation and non-essential water uses 	\$730 - \$2,040
30-50%	<ul style="list-style-type: none"> ✓ Lost water utility revenues ✓ Elimination of landscape irrigation and non-essential water uses ✓ Rationing of indoor use 	\$2,040 - \$10,970
>50%	<ul style="list-style-type: none"> ✓ Lost water utility revenues ✓ Elimination of landscape irrigation and non-essential water uses ✓ Rationing of indoor use ✓ Restriction or elimination of commercial water use ✓ Importing water by tanker truck 	\$10,970 - varies
*Figures are rounded		

1.1.4 Industrial Water User Groups

Manufacturing

Impacts to manufacturing were estimated by distributing water shortages among industrial sectors at the county level. For example, if a planning group estimates that during a drought of record water supplies in County A would only meet 50 percent of total annual demands for manufactures in the county, we reduced output for each sector by 50 percent. Since projected manufacturing demands are based on TWDB Water Uses Survey data for each county, we only include IMPLAN sectors represented in the TWDB survey database. Some sectors in IMPLAN databases are not part of the TWDB database given that they use relatively small amounts of water - primarily for on-site sanitation and potable purposes. To maintain consistency between IMPLAN and TWDB databases, Standard Industrial Classification (SIC) codes both databases were cross referenced in county with shortages. Non-matches were excluded when calculating direct impacts.

Mining

The process of mining is very similar to that of manufacturing. We assume that within a given county, shortages would apply equally to relevant mining sectors, and IMPLAN sectors are cross referenced with TWDB data to ensure consistency.

In Texas, oil and gas extraction and sand and gravel (aggregates) operations are the primary mining industries that rely on large volumes of water. For sand and gravel, estimated output reductions are straightforward; however, oil and gas is more complicated for a number of reasons. IMPLAN does not necessarily report the physical extraction of minerals by geographic local, but rather the sales revenues reported by a particular corporation.

For example, at the state level revenues for IMPLAN sector 19 (oil and gas extraction) and sector 27 (drilling oil and gas wells) totals \$257 billion. Of this, nearly \$85 billion is attributed to Harris County. However, only a very small fraction (less than one percent) of actual production takes place in the county. To measure actual potential losses in well head capacity due to water shortages, we relied on county level production data from the Texas Railroad Commission (TRC) and average well-head market prices for crude and gas to estimate lost revenues in a given county. After which, we used to IMPLAN ratios to estimate resultant losses in income and employment.

Other considerations with respect to mining include:

- 1) Petroleum and gas extraction industry only uses water in significant amounts for secondary recovery. Known in the industry as enhanced or water flood extraction, secondary recovery involves pumping water down injection wells to increase underground pressure thereby pushing oil or gas into other wells. IMPLAN output numbers do not distinguish between secondary and non-secondary recovery. To account for the discrepancy, county-level TRC data that show the proportion of barrels produced using secondary methods were used to adjust IMPLAN data to reflect only the portion of sales attributed to secondary recovery.
- 2) A substantial portion of output from mining operations goes directly to businesses that are classified as manufacturing in our schema. Thus, multipliers measuring backward linkages for a given manufacturer might include impacts to a supplying mining operation. Care was taken not to double count in such situations if both a mining operation and a manufacturer were reported as having water shortages.

Steam-electric

At minimum without adequate cooling water, power plants cannot safely operate. As water availability falls below projected demands, water levels in lakes and rivers that provide cooling water would also decline. Low water levels could affect raw water intakes and outfalls at electrical generating units in several ways. For one, power plants are regulated by thermal emission guidelines that specify the maximum amount of heat that can go back into a river or lake via discharged cooling water. Low water levels could result in permit compliance issues due to reduced dilution and dispersion of heat and subsequent impacts on aquatic biota near outfalls.¹⁹ However, the primary concern would be a loss of head (i.e., pressure) over intake structures that would decrease flows through intake tunnels. This would affect safety related pumps, increase operating costs and/or result in sustained shut-downs. Assuming plants did shutdown, they would not be able to generate electricity.

¹⁹ Section 316 (b) of the Clean Water Act requires that thermal wastewater discharges do not harm fish and other wildlife.

Among all water use categories steam-electric is unique and cautions are needed when applying methods used in this study. Measured changes to an economy using input-output models stem directly from changes in sales revenues. In the case of water shortages, one assumes that businesses will suffer lost output if process water is in short supply. For power generation facilities this is true as well. However, the electric services sector in IMPLAN represents a corporate entity that may own and operate several electrical generating units in a given region. If one unit became inoperable due to water shortages, plants in other areas or generation facilities that do not rely heavily on water such as gas powered turbines might be able to compensate for lost generating capacity. Utilities could also offset lost production via purchases on the spot market.²⁰ Thus, depending upon the severity of the shortages and conditions at a given electrical generating unit, energy supplies for local and regional communities could be maintained. But in general, without enough cooling water, utilities would have to throttle back plant operations, forcing them to buy or generate more costly power to meet customer demands.

Measuring impacts end users of electricity is not part of this study as it would require extensive local and regional level analysis of energy production and demand. To maintain consistency with other water user groups, impacts of steam-electric water shortages are measured in terms of lost revenues (and hence income) and jobs associated with shutting down electrical generating units.

1.2 Social Impacts of Water Shortages

As the name implies, the effects of water shortages can be social or economic. Distinctions between the two are both semantic and analytical in nature – more so analytic in the sense that social impacts are harder to quantify. Nevertheless, social effects associated with drought and water shortages are closely tied to economic impacts. For example, they might include:

- demographic effects such as changes in population,
- disruptions in institutional settings including activity in schools and government,
- conflicts between water users such as farmers and urban consumers,
- health-related low-flow problems (e.g., cross-connection contamination, diminished sewage flows, increased pollutant concentrations),
- mental and physical stress (e.g., anxiety, depression, domestic violence),
- public safety issues from forest and range fires and reduced fire fighting capability,
- increased disease caused by wildlife concentrations,
- loss of aesthetic and property values, and
- reduced recreational opportunities.²¹

²⁰ Today, most utilities participate in large interstate “power pools” and can buy or sell electricity “on the grid” from other utilities or power marketers. Thus, assuming power was available to buy, and assuming that no contractual or physical limitations were in place such as transmission constraints; utilities could offset lost power that resulted from waters shortages with purchases via the power grid.

²¹ Based on information from the website of the National Drought Mitigation Center at the University of Nebraska Lincoln. Available online at: <http://www.drought.unl.edu/risk/impacts.htm>. See also, Vanclay, F. “*Social Impact Assessment*.” in Petts, J. (ed) *International Handbook of Environmental Impact Assessment*. 1999.

Social impacts measured in this study focus strictly on demographic effects including changes in population and school enrollment. Methods are based on demographic projection models developed by the Texas State Data Center and used by the TWDB for state and regional water planning. Basically, the social impact model uses results from the economic component of the study and assesses how changes in labor demand would affect migration patterns in a region. Declines in labor demand as measured using adjusted IMPLAN data are assumed to affect net economic migration in a given regional water planning area. Employment losses are adjusted to reflect the notion that some people would not relocate but would seek employment in the region and/or public assistance and wait for conditions to improve. Changes in school enrollment are simply the proportion of lost population between the ages of 5 and 17.

2. Results

Section 2 presents the results of the analysis at the regional level. Included are baseline economic data for each water use category, and estimated economics impacts of water shortages for water user groups with reported deficits. According to the 2011 *South Central Texas Regional Water Plan*, during severe drought irrigation, municipal, manufacturing, mining and steam-electric water user groups would experience water shortages in the absence of new water management strategies.

2.1 Overview of Regional Economy

On an annual basis, the South Central Texas economy generates \$82 billion in gross state product for Texas (\$76 billion in income and \$6 billion worth of business taxes) and supports 1,163,680 jobs (Table 8). Generating about \$11 billion worth of income per year manufacturing is the primary base economic sector in the region.²² Municipal sectors also generate substantial amounts of income and are major employers. However, while municipal sectors are the largest employer and source of wealth, many businesses that make up the municipal category such as restaurants and retail stores are non-basic industries meaning they exist to provide services to people who work would in base industries such as manufacturing, agriculture and mining. In other words, without base industries such agriculture, many municipal jobs in the region would not exist.

²² Base industries are those that supply markets outside of the region. These industries are crucial to the local economy and are called the economic base of a region. Appendix A shows how IMPLAN's 529 sectors were allocated to water use category, and shows economic data for each sector.

Table 8: The South Central Texas Regional Economy by Water User Group (\$millions)*						
Water Use Category	Total sales	Intermediate sales	Final sales	Jobs	Income	Business taxes
Irrigation	\$266.54	\$47.35	\$219.07	4,110	\$174.18	\$3.23
Livestock	\$889.48	\$644.74	\$244.74	13,506	\$134.69	\$14.13
Manufacturing	\$35,019.65	\$4,677.32	\$30,342.33	134,359	\$11,132.59	\$268.65
Mining	\$3,841.83	\$2,060.19	\$1,781.64	9,733	\$2,355.49	\$194.87
Steam-electric	\$534.13	\$150.26	\$383.87	1,312	\$370.93	\$63.26
Municipal	\$104,098.04	\$30,414.34	\$73,683.69	1,000,660	\$61,736.55	\$5,406.62
Regional total	\$144,649.67	\$37,994.20	\$106,655.34	1,163,680	\$75,904.43	\$5,950.76

^a Appendix 1 displays data for individual IMPLAN sectors that make up each water use category. Based on data from the Texas Water Development Board, and year 2006 data from the Minnesota IMPLAN Group, Inc.

2.2 Impacts of Agricultural Water Shortages

According to the 2011 *South Central Texas Regional Water Plan*, during severe drought the counties of Atascosa, Medina and Zavala would experiences shortages of irrigation water. Shortages range from about 1 to 76 percent of annual irrigation demands over the planning horizon, and farmers would be short 68,465 acre-feet in 2010 and 41,782 in 2060. Shortages would reduce gross state product (income plus state and local business taxes) by an estimated \$45 million per year in 2010 to \$33 million in 2060.

Table 9: Economic Impacts of Water Shortages for Irrigation Water User Groups (\$millions)			
Decade	Lost income from reduced crop production ^a	Lost state and local tax revenues from reduced crop production	Lost jobs from reduced crop production
2010	\$43.32	\$2.16	545
2020	\$40.63	\$2.03	511
2030	\$38.04	\$1.90	478
2040	\$35.55	\$1.77	447
2050	\$33.17	\$1.66	416
2060	\$31.13	\$1.55	391

^aChanges to income and business taxes are collectively equivalent to a decrease in gross state product, which is analogous to gross domestic product measured at the state rather than national level. Appendix 2 shows results by water user group.

2.3 Impacts of Municipal Water Shortages

Water shortages are projected to occur in a significant number of communities in the region. At the regional level, the estimated economic value of domestic water shortages totals \$715 million in 2010 and \$2,823 million in 2060 (Table 10). Due to curtailment of commercial business activity operation, municipal shortages would reduce gross state product (income plus taxes) by an estimated \$53 million in 2020 and \$3,780 million in 2060.

Table 10: Economic Impacts of Water Shortages for Municipal Water User Groups (\$millions)					
Decade	Monetary value of domestic water shortages	Lost income from reduced commercial business activity*	Lost state and local taxes from reduced commercial business activity	Lost jobs from reduced commercial business activity	Lost water utility revenues
2010	\$715.54	\$42.91	\$5.67	1,067	\$149.36
2020	\$1,479.80	\$1,417.03	\$7.66	1,512	\$212.55
2030	\$1,331.33	\$1,909.07	\$82.41	17,808	\$276.64
2040	\$1,805.79	\$2,547.77	\$111.92	24,229	\$340.64
2050	\$2,426.71	\$3,197.28	\$134.26	29,081	\$402.51
2060	\$2,823.29	\$3,621.31	\$157.25	34,108	\$468.01

*Changes to Income and business taxes are collectively equivalent to a decrease in gross state product, which is analogous to gross domestic product measured at the state rather than national level. Appendix 2 shows results by water user group.

2.4 Impacts of Manufacturing Water Shortages

Manufacturing water shortages in the region are projected to occur in Bexar, Calhoun, Comal and Victoria counties. In 2010, the planning group estimates that these manufacturers would be short about 6,539 acre-feet; and by 2060, this figure increases to nearly 43,072 acre-feet. Shortages of these magnitudes would reduce gross state product (income plus taxes) by an estimated \$179 million in 2010 and \$2,080 million in 2060 (Table 11).

Table 11: Economic Impacts of Water Shortages for Manufacturing Water User Groups (\$millions)			
Decade	Lost income due to reduced manufacturing output	Lost state and local business tax revenues due to reduced manufacturing output	Lost jobs due to reduced manufacturing output
2010	\$146.77	\$22.22	8,274
2020	\$324.94	\$52.44	11,956
2030	\$496.18	\$81.52	15,436
2040	\$948.36	\$159.05	23,170
2050	\$1,451.00	\$245.34	31,553
2060	\$1,777.09	\$301.91	38,187

*Changes to Income and business taxes are collectively equivalent to a decrease in gross state product, which is analogous to gross domestic product measured at the state rather than national level. Appendix 2 shows results by water user group.

2.5 Impacts of Mining Water Shortages

Mining water shortages in Region L are projected to occur in Bexar, Comal and Hays counties and would primarily affect aggregates operations (e.g., sand and gravel producers). Combined shortages for each county would result in estimated losses in gross state product totaling \$3 million dollars in 2010, and about \$7 million 2060 (Table 12).

Table 12: Economic Impacts of Water Shortages for Mining Water User Groups (\$millions)			
Decade	Lost income due to reduced mining output	Lost state and local business tax revenues due to reduced mining output	Lost jobs due to reduced mining output
2010	\$2.67	\$0.14	27
2020	\$3.12	\$0.17	31
2030	\$4.64	\$0.34	53
2040	\$5.01	\$0.37	57
2050	\$6.44	\$0.48	72
2060	\$6.81	\$0.51	77

*Changes to Income and business taxes are collectively equivalent to a decrease in gross state product, which is analogous to gross domestic product measured at the state rather than national level. Appendix 2 shows results by water user group.

2.6 Impacts of Steam-electric Water Shortages

Water shortages for electrical generating units are projected to occur in Atascosa and Victoria counties, and would result in estimated losses of gross state product totaling \$72 million in 2020, and \$4,011 million 2060 (Table 13).

Table 13: Economic Impacts of Water Shortages for Steam-electric Water User Groups (\$millions)			
Decade	Lost income due to reduced electrical generation	Lost state and local business tax revenues due to reduced electrical generation	Lost jobs due to reduced electrical generation
2010	\$63.17	\$9.07	215
2020	\$3,493.56	\$501.45	5,938
2030	\$3,495.55	\$501.73	5,941
2040	\$3,497.61	\$502.03	5,945
2050	\$3,503.90	\$502.93	5,963
2060	\$3,507.77	\$503.49	5,973

*Changes to Income and business taxes are collectively equivalent to a decrease in gross state product, which is analogous to gross domestic product measured at the state rather than national level. Appendix 2 shows results by water user group.

2.7 Social Impacts of Water Shortages

As discussed previously, estimated social impacts focus on changes in population and school enrollment in the region. In 2010, estimated population losses total 12,886 with corresponding reductions in school enrollment of 3,635 students (Table 14). In 2060, population in the region would decline by 54,411 and school enrollment would fall by 10,064.

Table 14: Social Impacts of Water Shortages (2010-2060)		
Year	Population Losses	Declines in School Enrollment
2010	12,886	3,635
2020	43,823	12,433
2030	58,402	15,470
2040	74,857	13,835
2050	86,896	16,049
2060	54,411	10,064

2.8 Distribution of Impacts by Major River Basin

Administrative rules require that impacts are presented by both planning region and major river basin. To meet rule requirements, impacts were allocated among basins based on the distribution of water shortages in relevant basins. For example, if 50 percent of water shortages in River Basin A and 50 percent occur in River Basin B, then impacts were split equally among the two basins. Table 15 displays the results.

Table 15: Distribution of Impacts by Major River Basin (2010-2060)						
River Basin	2010	2020	2030	2040	2050	2060
Colorado	<1%	<1%	<1%	<1%	<1%	<1%
Colorado-Lavaca	<1%	<1%	<1%	<1%	<1%	<1%
Guadalupe	7%	27%	27%	29%	30%	32%
Nueces	37%	22%	19%	16%	14%	12%
San Antonio	57%	51%	55%	57%	57%	58%

Appendix 1: Economic Data for Individual IMPLAN Sectors

Economic Data for Agricultural Water User Groups (\$millions)								
Water Use Category	IMPLAN Sector	IMPLAN Code	Total Sales	Intermediate Sales	Final Sales	Jobs	Income	Business Taxes
Irrigation	Oilseeds	1	\$0.36	\$0.01	\$0.34	10	\$0.19	\$0.01
Irrigation	Grains	2	\$25.64	\$4.34	\$21.30	1,145	\$11.80	\$0.46
Irrigation	Vegetable and melons	3	\$178.72	\$11.67	\$167.05	2,122	\$131.27	\$1.68
Irrigation	Tree nuts	4	\$10.65	\$6.75	\$3.82	154	\$7.37	\$0.26
Irrigation	Fruits	5	\$8.48	\$1.24	\$7.18	172	\$4.82	\$0.18
Irrigation	Cotton	8	\$17.60	\$0.29	\$17.34	212	\$6.48	\$0.16
	All other crops	10	\$25.09	\$23.05	\$2.04	295	\$12.25	\$0.48
	Total irrigation		\$266.54	\$47.35	\$219.07	4,110	\$174.18	\$3.23
Livestock	Cattle ranching and farming	11	\$605.58	\$419.90	\$185.67	10,638	\$47.84	\$12.73
Livestock	Poultry and egg production	12	\$247.53	\$194.00	\$53.53	834	\$83.31	\$0.84
Livestock	Animal production- except cattle and poultry	13	\$36.37	\$30.84	\$5.53	2,034	\$3.54	\$0.56
	Total livestock	-	\$889.48	\$644.74	\$244.74	13,506	\$134.69	\$14.13
	Total agriculture	-	\$1,156.02	\$692.09	\$463.81	17,616	\$308.87	\$17.36
Based on year 2006 data from the Minnesota IMPLAN Group, Inc.								

Economic Data for Mining and Steam-electric Water User Groups (\$millions)								
Water Use Category	IMPLAN Sector	IMPLAN Code	Intermediate		Jobs	Income	Business Taxes	
			Total Sales	Sales				
Mining	Oil and gas extraction	19	\$1,996.63	\$1,854.24	\$142.38	3,290	\$1,148.96	\$120.59
Mining	Support activities for oil and gas operations	28	\$1,026.56	\$142.59	\$883.98	4,522	\$930.58	\$42.34
Mining	Drilling oil and gas wells	27	\$577.01	\$2.88	\$574.13	997	\$150.15	\$19.80
Mining	Sand- gravel- clay- and refractory mining	25	\$92.43	\$9.76	\$82.67	537	\$54.54	\$2.53
Mining	Coal mining	20	\$64.63	\$24.22	\$40.41	207	\$23.55	\$7.12
Mining	Stone mining and quarrying	24	\$44.53	\$4.58	\$39.95	149	\$26.40	\$0.27
Mining	Gold- silver- and other metal ore mining	23	\$39.13	\$21.85	\$17.27	27	\$20.87	\$2.20
Mining	Other nonmetallic mineral mining	26	\$0.58	\$0.06	\$0.52	3	\$0.26	\$0.02
Mining	Support activities for other mining	29	\$0.33	\$0.00	\$0.33	1	\$0.19	\$0.00
	Total mining		\$534.13	\$150.26	\$383.87	1,312	\$370.93	\$63.26
Steam-electric	Power generation and supply	30	\$3,841.83	\$2,060.19	\$1,781.64	9,733	\$2,355.49	\$194.87

Based on year 2006 data from the Minnesota IMPLAN Group, Inc.

Economic Data for Manufacturing Water User Groups (\$millions)								
Water Use Category	IMPLAN Sector	IMPLAN Code	Total Sales	Intermediate		Jobs	Income	Business Taxes
				Sales	Final Sales			
Manufacturing	New residential 1-unit structures- all	33	\$3,607.93	\$0.00	\$3,607.92	23,970	\$1,220.47	\$19.21
Manufacturing	Plastics material and resin manufacturing	152	\$2,571.32	\$101.83	\$2,469.49	1,813	\$469.87	\$15.37
Manufacturing	Petroleum refineries	142	\$2,362.74	\$878.23	\$1,484.51	141	\$1,068.08	\$39.12
Manufacturing	Commercial and institutional buildings	38	\$2,045.58	\$0.00	\$2,045.58	20,895	\$1,045.42	\$12.89
Manufacturing	Automobile and light truck manufacturing	344	\$1,659.11	\$1.77	\$1,657.33	1,127	\$209.81	\$5.74
Manufacturing	Pharmaceutical and medicine manufacturing	160	\$1,302.79	\$238.08	\$1,064.71	1,218	\$457.37	\$10.82
Manufacturing	Aircraft manufacturing	351	\$1,231.30	\$62.64	\$1,168.65	2,422	\$220.90	\$3.78
Manufacturing	Alumina refining	208	\$1,119.35	\$50.99	\$1,068.35	1,268	\$238.82	\$20.42
Manufacturing	Soft drink and ice manufacturing	85	\$1,048.19	\$58.55	\$989.64	1,643	\$163.97	\$7.26
Manufacturing	Other new construction	41	\$893.86	\$0.00	\$893.86	9,585	\$484.91	\$3.82
Manufacturing	Iron and steel mills	203	\$811.22	\$58.43	\$752.78	873	\$210.18	\$7.81
Manufacturing	Motor vehicle parts manufacturing	350	\$759.01	\$61.03	\$697.98	2,009	\$196.86	\$3.17
Manufacturing	Meat processed from carcasses	68	\$596.94	\$176.11	\$420.83	1,360	\$66.29	\$3.43
Manufacturing	New residential additions and alterations-all	35	\$514.58	\$0.00	\$514.58	2,855	\$193.43	\$2.73
Manufacturing	Wood kitchen cabinet and countertop manufacturing	362	\$480.41	\$374.24	\$106.18	3,866	\$209.65	\$3.47
Manufacturing	AC- refrigeration- and forced air heating	278	\$459.38	\$0.00	\$459.38	1,443	\$100.71	\$2.64
Manufacturing	Highway- street- bridge- and tunnel construct	39	\$439.94	\$0.00	\$439.94	4,046	\$223.89	\$2.85
Manufacturing	Pesticide and other agricultural chemical man	159	\$415.02	\$69.54	\$345.48	200	\$162.38	\$2.85
Manufacturing	Bread and bakery product- except frozen- manufacturing	73	\$411.42	\$91.87	\$319.55	2,551	\$182.21	\$2.93
Manufacturing	New multifamily housing structures- all	34	\$396.64	\$0.00	\$396.64	3,482	\$188.50	\$1.09
Manufacturing	Cement manufacturing	191	\$394.93	\$1.06	\$393.87	407	\$201.94	\$4.12
Manufacturing	Other basic organic chemical manufacturing	151	\$348.82	\$65.03	\$283.78	302	\$54.93	\$2.20
Manufacturing	Aircraft engine and engine parts manufacturing	352	\$344.04	\$94.27	\$249.77	910	\$71.12	\$1.01
Manufacturing	Other animal food manufacturing	47	\$331.48	\$39.98	\$291.50	465	\$29.31	\$2.24
Manufacturing	Water- sewer- and pipeline construction	40	\$319.41	\$0.00	\$319.41	2,649	\$143.64	\$2.08
Manufacturing	Ready-mix concrete manufacturing	192	\$316.77	\$1.54	\$315.23	1,003	\$121.49	\$3.30
Manufacturing	All other manufacturing	-	\$9,837.48	\$2,252.12	\$7,585.36	41,856	\$3,196.44	\$82.30
Manufacturing	Total manufacturing	-	\$35,019.65	\$4,677.32	\$30,342.33	134,359	\$11,132.59	\$268.65

Based on year 2006 data from the Minnesota IMPLAN Group, Inc.

Economic Data for Municipal Water User Groups (\$millions)

Water Use Category	IMPLAN Sector	IMPLAN Code	Intermediate		Jobs	Income	Business Taxes	
			Total Sales	Sales				Final Sales
Municipal	Owner-occupied dwellings	509	\$6,426.35	\$0.00	\$6,426.35	0	\$4,978.29	\$759.88
Municipal	Wholesale trade	390	\$6,141.21	\$2,940.19	\$3,201.02	36,563	\$3,233.08	\$908.45
Municipal	Real estate	431	\$5,071.02	\$2,007.38	\$3,063.64	27,385	\$2,934.53	\$624.25
Municipal	Insurance carriers	427	\$4,588.64	\$1,338.03	\$3,250.60	16,586	\$1,813.63	\$225.94
Municipal	Monetary authorities and depository credit in	430	\$4,297.56	\$1,415.42	\$2,882.14	17,925	\$3,017.82	\$54.97
Municipal	Food services and drinking places	481	\$4,044.01	\$516.41	\$3,527.59	80,052	\$1,729.17	\$202.02
Municipal	State & Local Education	503	\$3,973.22	\$0.00	\$3,973.22	92,541	\$3,973.22	\$0.00
Municipal	Federal Military	505	\$3,676.66	\$0.01	\$3,676.66	34,658	\$3,676.66	\$0.00
Municipal	Offices of physicians- dentists- and other he	465	\$3,582.61	\$0.00	\$3,582.61	29,480	\$2,549.08	\$22.39
Municipal	Telecommunications	422	\$3,560.49	\$1,222.96	\$2,337.52	7,129	\$1,623.90	\$270.70
Municipal	Hospitals	467	\$2,687.75	\$0.00	\$2,687.74	22,732	\$1,461.31	\$18.67
Municipal	Motor vehicle and parts dealers	401	\$2,090.72	\$227.34	\$1,863.37	18,289	\$1,083.57	\$306.77
Municipal	State & Local Non-Education	504	\$1,971.28	\$0.00	\$1,971.28	34,133	\$1,971.28	\$0.00
Municipal	Pipeline transportation	396	\$1,964.70	\$859.23	\$1,105.47	1,251	\$835.12	\$178.13
Municipal	Truck transportation	394	\$1,909.79	\$1,034.09	\$875.69	17,671	\$734.47	\$16.89
Municipal	Federal Non-Military	506	\$1,666.73	\$0.01	\$1,666.72	9,364	\$1,666.72	\$0.00
Municipal	Management of companies and enterprises	451	\$1,665.00	\$1,565.78	\$99.22	7,815	\$1,007.27	\$16.08
Municipal	Architectural and engineering services	439	\$1,580.82	\$996.49	\$584.33	12,844	\$849.85	\$7.03
Municipal	Hotels and motels- including casino hotels	479	\$1,427.17	\$735.24	\$691.93	14,042	\$790.79	\$135.39
Municipal	General merchandise stores	410	\$1,257.83	\$132.57	\$1,125.26	21,584	\$579.77	\$184.49
Municipal	Other State and local government enterprises	499	\$1,216.82	\$396.23	\$820.59	5,493	\$477.38	\$0.16
Municipal	Legal services	437	\$1,201.39	\$762.47	\$438.92	9,070	\$760.65	\$23.62
Municipal	Other ambulatory health care services	466	\$1,165.44	\$75.80	\$1,089.64	8,243	\$566.52	\$8.44
Municipal	Food and beverage stores	405	\$1,124.71	\$150.37	\$974.34	18,856	\$578.36	\$126.75
Municipal	Funds- trusts- and other financial vehicles	429	\$1,119.37	\$21.23	\$1,098.14	3,732	\$246.75	\$9.89
Municipal	Securities- commodity contracts- investments	426	\$1,110.71	\$737.61	\$373.10	9,095	\$411.31	\$12.11
Municipal	All other municipal		\$29,595.50	\$11,187.27	\$18,408.23	409,988	\$15,779.81	\$1,260.49
Manufacturing	Total		\$100,117.50	\$28,322.13	\$71,795.32	966,521	\$59,330.31	\$5,373.51

Based on year 2006 data from the Minnesota IMPLAN Group, Inc.

Appendix 2: Impacts by Water User Group

Irrigation (\$millions)						
	2010	2020	2030	2040	2050	2060
Atascosa County						
Reduced income from lost crop production	\$1.13	\$0.88	\$0.63	\$0.40	\$0.17	\$0.05
Reduced business taxes from lost crop production	\$0.05	\$0.04	\$0.03	\$0.02	\$0.01	\$0.00
Reduced jobs from lost crop production	13	10	7	5	2	1
Medina County						
Reduced income from lost crop production	\$1.29	\$0.98	\$0.68	\$0.39	\$0.11	\$0.00
Reduced business taxes from lost crop production	\$0.07	\$0.05	\$0.03	\$0.02	\$0.01	\$0.00
Reduced jobs from lost crop production	19	14	10	6	2	0
Zavala County						
Reduced income from lost crop production	\$40.90	\$38.77	\$36.73	\$34.77	\$32.89	\$31.08
Reduced business taxes from lost crop production	\$2.04	\$1.94	\$1.83	\$1.74	\$1.64	\$1.55
Reduced jobs from lost crop production	513	487	461	436	413	390

Manufacturing (\$millions)						
	2010	2020	2030	2040	2050	2060
Bexar County						
Reduced income from lost manufacturing	\$32.89	\$119.92	\$202.26	\$566.31	\$708.72	\$863.34
Reduced business taxes from lost manufacturing	\$5.67	\$20.68	\$34.87	\$97.64	\$122.19	\$148.85
Reduced jobs from lost crop livestock manufacturing	501	1,826	3,080	8,624	10,793	13,148
Calhoun County						
Reduced income from lost manufacturing	\$0.00	\$0.00	\$0.00	\$0.00	\$0.00	\$7.27
Reduced business taxes from lost manufacturing	\$0.00	\$0.00	\$0.00	\$0.00	\$0.00	\$2.12
Reduced jobs from lost crop livestock manufacturing	0	0	0	0	0	755
Comal County						
Reduced income from lost manufacturing	\$113.88	\$132.15	\$148.60	\$164.59	\$178.32	\$197.62
Reduced business taxes from lost manufacturing	\$16.55	\$19.21	\$21.60	\$23.92	\$25.92	\$28.72
Reduced jobs from lost crop livestock manufacturing	7,773	9,020	10,143	11,234	12,171	13,488
Victoria County						
Reduced income from lost manufacturing	\$0.00	\$72.87	\$145.32	\$217.45	\$563.96	\$708.86
Reduced business taxes from lost manufacturing	\$0.00	\$12.56	\$25.06	\$37.49	\$97.23	\$122.22
Reduced jobs from lost crop livestock manufacturing	0	1,110	2,213	3,312	8,588	10,795

Mining (\$millions)						
	2010	2020	2030	2040	2050	2060
Bexar County						
Reduced income from lost mining output	\$0.00	\$0.00	\$1.25	\$1.38	\$1.52	\$1.65
Reduced business taxes from lost mining output	\$0.00	\$0.00	\$0.15	\$0.17	\$0.19	\$0.20
Reduced jobs from lost mining output	0	0	18	20	22	24
Comal County						
Reduced income from lost mining output	\$0.44	\$0.64	\$0.76	\$0.87	\$2.15	\$2.36
Reduced business taxes from lost mining output	\$0.03	\$0.05	\$0.05	\$0.06	\$0.15	\$0.17
Reduced jobs from lost mining output	5	7	8	9	22	24
Hays County						
Reduced income from lost mining output	\$2.23	\$2.48	\$2.64	\$2.75	\$2.78	\$2.80
Reduced business taxes from lost mining output	\$0.11	\$0.12	\$0.13	\$0.14	\$0.14	\$0.14
Reduced jobs from lost mining output	22	25	26	27	28	28

Steam-electric (\$millions)						
	2010	2020	2030	2040	2050	2060
Atascosa County						
Reduced income from lost electrical generation	\$1.78	\$0.00	\$0.00	\$0.00	\$4.10	\$6.39
Reduced business taxes from lost electrical generation	\$0.26	\$0.00	\$0.00	\$0.00	\$0.59	\$0.92
Reduced jobs from lost electrical generation	6	0	0	0	14	22
Victoria County						
Reduced income from lost electrical generation	\$61.39	\$3,493.56	\$3,495.55	\$3,497.61	\$3,499.80	\$3,501.38
Reduced business taxes from lost electrical generation	\$8.81	\$501.45	\$501.73	\$502.03	\$502.34	\$502.57
Reduced jobs from lost electrical generation	209	5938	5941	5945	5949	5951

Municipal (\$millions)						
	2010	2020	2030	2040	2050	2060
Alamo Heights						
Monetary value of domestic water shortages	\$0.96	\$1.06	\$1.07	\$1.06	\$1.08	\$1.12
Lost utility revenues	\$1.06	\$1.18	\$1.18	\$1.17	\$1.20	\$1.24
Aqua WSC						
Monetary value of domestic water shortages	\$0.10	\$1.68	\$4.04	\$3.70	\$4.53	\$5.42
Lost income from reduced commercial business activity	\$0.00	\$0.00	\$0.00	\$0.17	\$0.23	\$0.30
Lost jobs due to reduced commercial business activity	0	0	0	7	9	12
Lost state and local taxes from reduced commercial business activity	\$0.00	\$0.00	\$0.00	\$0.03	\$0.04	\$0.05
Lost utility revenues	\$0.10	\$0.24	\$0.35	\$0.48	\$0.59	\$0.72
Atascosa Rural WSC						
Monetary value of domestic water shortages	\$9.49	\$11.95	\$15.32	\$17.74	\$19.56	\$21.76
Lost income from reduced commercial business activity	\$2.11	\$3.07	\$3.92	\$4.63	\$5.24	\$5.87
Lost jobs due to reduced commercial business activity	47	68	87	103	117	131
Lost state and local taxes from reduced commercial business activity	\$0.22	\$0.33	\$0.42	\$0.49	\$0.56	\$0.62
Lost utility revenues	\$0.98	\$1.29	\$1.56	\$1.79	\$1.99	\$2.19
Benton City WSC						
Monetary value of domestic water shortages	\$0.00	\$0.00	\$0.23	\$0.64	\$3.12	\$3.92
Lost utility revenues	\$0.00	\$0.00	\$0.36	\$0.83	\$1.28	\$1.63
Bexar Met Water District						
Monetary value of domestic water shortages	\$29.85	\$43.51	\$52.16	\$59.71	\$68.58	\$82.71
Lost income from reduced commercial business activity	\$8.43	\$13.75	\$19.10	\$23.71	\$28.77	\$34.02
Lost jobs due to reduced commercial business activity	136	222	308	382	464	548
Lost state and local taxes from reduced commercial business activity	\$0.76	\$1.24	\$1.72	\$2.13	\$2.59	\$3.06
Lost utility revenues	\$7.23	\$8.43	\$9.92	\$10.75	\$11.88	\$13.15

Municipal (cont.)						
	2010	2020	2030	2040	2050	2060
Boerne						
Monetary value of domestic water shortages	\$0.00	\$0.00	\$0.00	\$0.00	\$0.00	\$0.25
Lost utility revenues	\$0.00	\$0.00	\$0.00	\$0.00	\$0.00	\$0.50
Bulverde City						
Monetary value of domestic water shortages	\$6.31	\$24.37	\$39.17	\$59.32	\$75.71	\$93.29
Lost income from reduced commercial business activity	\$2.26	\$5.50	\$9.19	\$12.86	\$16.68	\$20.77
Lost jobs due to reduced commercial business activity	91	221	369	517	671	835
Lost state and local taxes from reduced commercial business activity	\$0.32	\$0.78	\$1.31	\$1.83	\$2.38	\$2.96
Lost utility revenues	\$1.17	\$2.41	\$3.83	\$5.23	\$6.69	\$8.26
Canyon Lake WSC						
Monetary value of domestic water shortages	\$0.00	\$0.00	\$0.11	\$3.17	\$25.78	\$47.65
Lost utility revenues	\$0.00	\$0.00	\$0.23	\$3.95	\$8.03	\$12.17
Castle Hills						
Monetary value of domestic water shortages	\$0.12	\$0.10	\$0.08	\$0.07	\$0.05	\$0.05
Lost utility revenues	\$0.19	\$0.16	\$0.14	\$0.11	\$0.09	\$0.09
Castroville						
Monetary value of domestic water shortages	\$3.63	\$4.28	\$5.55	\$8.93	\$9.88	\$10.75
Lost income from reduced commercial business activity	\$0.94	\$1.41	\$1.84	\$2.22	\$2.68	\$3.08
Lost jobs due to reduced commercial business activity	22	33	43	51	61	70
Lost state and local taxes from reduced commercial business activity	\$0.79	\$1.17	\$1.54	\$1.86	\$2.19	\$2.51
Lost utility revenues	\$0.58	\$0.71	\$0.82	\$0.93	\$1.03	\$1.14
Converse						
Monetary value of domestic water shortages	\$0.00	\$0.00	\$0.12	\$0.51	\$0.92	\$1.57
Lost utility revenues	\$0.00	\$0.00	\$0.24	\$0.81	\$1.29	\$1.74
County Line WSC						
Monetary value of domestic water shortages	\$0.00	\$13.95	\$20.67	\$22.12	\$32.21	\$41.84
Lost income from reduced commercial business activity	\$0.00	\$1.99	\$2.98	\$3.21	\$3.89	\$5.04
Lost jobs due to reduced commercial business activity	0	80	120	129	156	203
Lost state and local taxes from reduced commercial business activity	\$0.00	\$0.31	\$0.46	\$0.50	\$0.60	\$0.78
Lost utility revenues	\$0.00	\$1.89	\$2.59	\$2.91	\$3.50	\$4.35

Municipal (cont.)						
	2010	2020	2030	2040	2050	2060
County-other (Bexar)						
Monetary value of domestic water shortages	\$0.00	\$0.00	\$0.00	\$0.11	\$0.37	\$0.67
County-other (Comal)						
Monetary value of domestic water shortages	\$18.36	\$23.89	\$26.38	\$34.60	\$39.04	\$43.36
County-other (Kendall)						
Monetary value of domestic water shortages	\$0.23	\$1.11	\$2.47	\$10.95	\$15.73	\$24.74
County-other (Medina)						
Monetary value of domestic water shortages	\$0.00	\$0.27	\$0.76	\$1.28	\$6.09	\$8.23
County-other (Victoria)						
Monetary value of domestic water shortages	\$0.00	\$0.00	\$0.00	\$0.07	\$0.18	\$0.32
County-other (Wilson)						
Monetary value of domestic water shortages	\$0.00	\$0.00	\$0.00	\$0.00	\$0.00	\$0.03
Creedmore –Maha WSC						
Monetary value of domestic water shortages	\$1.07	\$2.73	\$4.75	\$5.90	\$7.07	\$8.75
Lost income from reduced commercial business activity	\$0.00	\$0.38	\$0.58	\$0.79	\$0.99	\$1.21
Lost jobs due to reduced commercial business activity	0	15	23	32	40	48
Lost state and local taxes from reduced commercial business activity	\$0.00	\$0.06	\$0.09	\$0.12	\$0.15	\$0.19
Lost utility revenues	\$0.21	\$0.36	\$0.49	\$0.62	\$0.75	\$0.89
Crystal Clear WSC						
Monetary value of domestic water shortages	\$0.00	\$0.00	\$0.67	\$3.07	\$14.98	\$23.52
Lost income from reduced commercial business activity	\$0.00	\$0.00	\$0.00	\$0.00	\$0.00	\$0.63
Lost jobs due to reduced commercial business activity	0	0	0	0	0	25
Lost state and local taxes from reduced commercial business activity	\$0.00	\$0.00	\$0.00	\$0.00	\$0.00	\$0.10
Lost utility revenues	\$0.00	\$0.00	\$0.79	\$1.78	\$3.05	\$4.30

Municipal (cont.)						
	2010	2020	2030	2040	2050	2060
East Central WSC						
Monetary value of domestic water shortages	\$0.00	\$0.00	\$0.28	\$0.69	\$1.87	\$3.45
Lost utility revenues	\$0.00	\$0.00	\$0.46	\$0.91	\$1.32	\$1.74
East Medina SUD						
Monetary value of domestic water shortages	\$0.00	\$0.11	\$0.27	\$0.44	\$0.64	\$2.59
Lost utility revenues	\$0.00	\$0.19	\$0.38	\$0.54	\$0.71	\$0.88
Floresville						
Monetary value of domestic water shortages	\$0.00	\$0.00	\$0.00	\$0.00	\$0.15	\$0.50
Lost utility revenues	\$0.00	\$0.00	\$0.00	\$0.00	\$0.29	\$0.78
Garden Ridge						
Monetary value of domestic water shortages	\$2.54	\$5.97	\$9.83	\$13.42	\$16.68	\$20.57
Lost income from reduced commercial business activity	\$0.00	\$0.58	\$0.92	\$1.27	\$1.62	\$2.01
Lost jobs due to reduced commercial business activity	0	23	37	51	65	81
Lost state and local taxes from reduced commercial business activity	\$0.00	\$0.09	\$0.14	\$0.20	\$0.25	\$0.31
Lost utility revenues	\$0.51	\$0.78	\$1.09	\$1.41	\$1.73	\$2.08
Goforth WSC						
Monetary value of domestic water shortages	\$0.00	\$0.02	\$0.56	\$4.64	\$10.05	\$12.53
Lost income from reduced commercial business activity	\$0.00	\$0.00	\$0.00	\$0.00	\$0.00	\$2.58
Lost jobs due to reduced commercial business activity	0	0	0	0	0	104
Lost state and local taxes from reduced commercial business activity	\$0.00	\$0.00	\$0.00	\$0.00	\$0.00	\$0.40
Lost utility revenues	\$0.00	\$0.05	\$0.80	\$1.61	\$2.61	\$3.43

Municipal (cont.)						
	2010	2020	2030	2040	2050	2060
Green Valley WSC						
Monetary value of domestic water shortages	\$0.00	\$0.00	\$0.00	\$0.00	\$0.00	\$0.68
Lost utility revenues	\$0.00	\$0.00	\$0.00	\$0.00	\$0.00	\$1.17
Hill Country Village						
Monetary value of domestic water shortages	\$26.38	\$26.27	\$26.12	\$26.01	\$25.94	\$25.94
Lost income from reduced commercial business activity	\$4.30	\$4.28	\$4.25	\$4.23	\$4.22	\$4.22
Lost jobs due to reduced commercial business activity	136	135	134	134	133	133
Lost state and local taxes from reduced commercial business activity	\$0.61	\$0.61	\$0.61	\$0.60	\$0.60	\$0.60
Lost utility revenues	\$1.45	\$1.44	\$1.43	\$1.43	\$1.42	\$1.42
Hollywood Park						
Monetary value of domestic water shortages	\$40.26	\$41.77	\$43.17	\$44.23	\$45.32	\$46.35
Lost income from reduced commercial business activity	\$8.29	\$8.63	\$8.95	\$9.19	\$9.43	\$9.66
Lost jobs due to reduced commercial business activity	261	272	282	290	297	305
Lost state and local taxes from reduced commercial business activity	\$1.18	\$1.23	\$1.27	\$1.31	\$1.34	\$1.38
Lost utility revenues	\$3.90	\$4.05	\$4.18	\$4.29	\$4.40	\$4.50
Hondo						
Monetary value of domestic water shortages	\$0.41	\$0.87	\$3.91	\$5.25	\$6.88	\$7.95
Lost utility revenues	\$0.57	\$0.96	\$1.33	\$1.63	\$1.95	\$2.25
Jourdanton						
Monetary value of domestic water shortages	\$0.16	\$0.27	\$0.35	\$0.54	\$0.62	\$0.69
Lost utility revenues	\$0.22	\$0.34	\$0.45	\$0.53	\$0.61	\$0.67
Karnes City						
Monetary value of domestic water shortages	\$1.64	\$1.83	\$2.46	\$2.65	\$2.77	\$2.87
Lost utility revenues	\$0.36	\$0.40	\$0.44	\$0.48	\$0.50	\$0.52

Municipal (cont.)						
	2010	2020	2030	2040	2050	2060
Kenedy						
Monetary value of domestic water shortages	\$0.00	\$0.00	\$0.00	\$0.04	\$0.10	\$0.16
Lost utility revenues	\$0.00	\$0.00	\$0.00	\$0.07	\$0.17	\$0.23
Kirby						
Monetary value of domestic water shortages	\$1.77	\$1.76	\$1.78	\$1.75	\$1.81	\$1.92
Lost utility revenues	\$0.60	\$0.60	\$0.61	\$0.60	\$0.62	\$0.65
Kyle						
Monetary value of domestic water shortages	\$0.00	\$0.45	\$0.92	\$1.12	\$2.22	\$2.76
Lost utility revenues	\$0.00	\$0.78	\$1.28	\$1.57	\$2.46	\$3.05
Lacoste						
Monetary value of domestic water shortages	\$0.91	\$1.20	\$1.20	\$1.43	\$1.76	\$1.95
Lost income from reduced commercial business activity	\$0.00	\$0.00	\$0.17	\$0.19	\$0.22	\$0.26
Lost jobs due to reduced commercial business activity	0	0	7	8	9	10
Lost state and local taxes from reduced commercial business activity	\$0.00	\$0.00	\$0.03	\$0.03	\$0.03	\$0.04
Lost utility revenues	\$0.18	\$0.22	\$0.25	\$0.27	\$0.30	\$0.33
Lockhart						
Monetary value of domestic water shortages	\$0.00	\$0.33	\$1.23	\$7.43	\$11.27	\$17.68
Lost utility revenues	\$0.00	\$0.58	\$1.54	\$2.53	\$3.51	\$4.52
Luling						
Monetary value of domestic water shortages	\$0.00	\$0.12	\$0.24	\$0.38	\$0.65	\$0.82
Lost utility revenues	\$0.00	\$0.22	\$0.38	\$0.53	\$0.72	\$0.91
Lytle						
Monetary value of domestic water shortages	\$0.32	\$0.39	\$0.45	\$1.44	\$1.54	\$1.63
Lost utility revenues	\$0.28	\$0.30	\$0.32	\$0.33	\$0.35	\$0.37
Marion						
Monetary value of domestic water shortages	\$0.00	\$0.00	\$0.02	\$0.05	\$0.09	\$0.15
Lost utility revenues	\$0.00	\$0.01	\$0.04	\$0.07	\$0.10	\$0.15

Municipal (cont.)						
	2010	2020	2030	2040	2050	2060
Martindale WSC						
Monetary value of domestic water shortages	\$0.06	\$0.38	\$0.76	\$1.52	\$2.21	\$2.88
Lost utility revenues	\$0.08	\$0.14	\$0.19	\$0.25	\$0.30	\$0.36
Maxwell WSC						
Monetary value of domestic water shortages	\$0.00	\$0.00	\$0.09	\$0.43	\$0.74	\$5.25
Lost utility revenues	\$0.00	\$0.00	\$0.15	\$0.49	\$0.94	\$1.36
McCoy WSC						
Monetary value of domestic water shortages	\$0.00	\$0.02	\$0.48	\$1.07	\$1.99	\$5.63
Lost utility revenues	\$0.00	\$0.02	\$0.38	\$0.79	\$1.18	\$1.48
Mountain City						
Monetary value of domestic water shortages	\$0.00	\$0.04	\$0.54	\$1.04	\$2.45	\$3.04
Lost utility revenues	\$0.00	\$0.04	\$0.10	\$0.15	\$0.21	\$0.27
Mustang Ridge						
Monetary value of domestic water shortages	\$0.03	\$0.51	\$0.98	\$1.68	\$2.43	\$3.41
Lost utility revenues	\$0.04	\$0.12	\$0.20	\$0.27	\$0.35	\$0.42
Natalia						
Monetary value of domestic water shortages	\$2.92	\$4.25	\$5.23	\$5.93	\$6.56	\$7.16
Lost income from reduced commercial business activity	\$0.55	\$0.73	\$0.89	\$1.04	\$1.18	\$1.31
Lost jobs due to reduced commercial business activity	17	23	28	33	37	41
Lost state and local taxes from reduced commercial business activity	\$0.08	\$0.10	\$0.13	\$0.15	\$0.17	\$0.19
Lost utility revenues	\$0.38	\$0.47	\$0.55	\$0.62	\$0.69	\$0.76
New Braunfels						
Monetary value of domestic water shortages	\$0.00	\$0.91	\$8.24	\$40.33	\$63.55	\$105.08
Lost income from reduced commercial business activity	\$0.00	\$0.00	\$1.79	\$5.14	\$8.84	\$12.91
Lost jobs due to reduced commercial business activity	0	0	40	114	197	287
Lost state and local taxes from reduced commercial business activity	\$0.00	\$0.00	\$0.19	\$0.55	\$0.94	\$1.37
Lost utility revenues	\$0.00	\$1.65	\$7.34	\$12.97	\$18.80	\$25.25

Municipal (cont.)						
	2010	2020	2030	2040	2050	2060
Niederwald						
Monetary value of domestic water shortages	\$0.56	\$1.84	\$3.44	\$5.86	\$7.61	\$9.05
Lost utility revenues	\$0.11	\$0.23	\$0.36	\$0.48	\$0.63	\$0.75
Oak Hills WSC						
Monetary value of domestic water shortages	\$0.00	\$0.00	\$0.00	\$0.00	\$0.00	\$0.41
Lost utility revenues	\$0.00	\$0.00	\$0.00	\$0.00	\$0.00	\$0.59
Plum Creek Water Co.						
Monetary value of domestic water shortages	\$0.00	\$0.00	\$0.00	\$0.25	\$2.40	\$3.79
Lost utility revenues	\$0.00	\$0.00	\$0.00	\$0.35	\$0.82	\$1.18
Point Comfort						
Monetary value of domestic water shortages	\$0.07	\$1.44	\$5.15	\$9.38	\$9.19	\$9.19
Lost utility revenues	\$0.09	\$0.29	\$0.64	\$0.99	\$0.97	\$0.97
Polonia WSC						
Monetary value of domestic water shortages	\$0.00	\$0.00	\$0.00	\$0.00	\$0.06	\$0.30
Lost utility revenues	\$0.00	\$0.00	\$0.00	\$0.00	\$0.12	\$0.48
Sabinal						
Monetary value of domestic water shortages	\$0.18	\$0.17	\$0.16	\$0.16	\$0.15	\$0.15
Lost utility revenues	\$0.25	\$0.24	\$0.23	\$0.22	\$0.22	\$0.22
San Antonio						
Monetary value of domestic water shortages	\$505.60	\$1,169.02	\$914.55	\$1,223.47	\$1,613.29	\$1,769.69
Lost income from reduced commercial business activity	\$0.00	\$0.00	\$683.59	\$942.18	\$1,132.44	\$1,322.45
Lost jobs due to reduced commercial business activity	0	0	15,208	20,961	25,194	29,421
Lost state and local taxes from reduced commercial business activity	\$0.00	\$0.00	\$72.75	\$100.27	\$120.51	\$140.73
Lost utility revenues	\$117.71	\$165.77	\$205.50	\$239.53	\$266.76	\$293.93
San Marcos						
Monetary value of domestic water shortages	\$0.00	\$0.00	\$1.35	\$7.74	\$49.10	\$80.16
Lost utility revenues	\$0.00	\$0.00	\$2.37	\$8.58	\$15.30	\$20.47

Municipal (cont.)						
	2010	2020	2030	2040	2050	2060
Santa Clara						
Monetary value of domestic water shortages	\$0.63	\$2.85	\$6.54	\$11.64	\$15.41	\$19.44
Lost utility revenues	\$0.15	\$0.41	\$0.69	\$0.96	\$1.27	\$1.60
Schertz						
Monetary value of domestic water shortages	\$0.00	\$0.00	\$0.00	\$0.00	\$0.67	\$3.15
Lost utility revenues	\$0.00	\$0.00	\$0.00	\$0.00	\$1.17	\$4.40
Selma						
Monetary value of domestic water shortages	\$0.00	\$0.56	\$1.54	\$1.52	\$2.01	\$2.63
Lost utility revenues	\$0.00	\$0.71	\$1.51	\$1.50	\$1.48	\$1.49
Shavano Park						
Monetary value of domestic water shortages	\$2.88	\$3.03	\$3.14	\$3.22	\$3.32	\$3.43
Lost utility revenues	\$0.63	\$0.67	\$0.69	\$0.71	\$0.73	\$0.75
SS WSC						
Monetary value of domestic water shortages	\$0.26	\$4.99	\$12.19	\$19.80	\$35.60	\$44.69
Lost utility revenues	\$0.40	\$1.55	\$2.78	\$3.98	\$5.28	\$6.63
Sunko WSC						
Monetary value of domestic water shortages	\$0.00	\$0.00	\$0.00	\$0.00	\$0.00	\$0.07
Lost utility revenues	\$0.00	\$0.00	\$0.00	\$0.00	\$0.00	\$0.14
Universal City						
Monetary value of domestic water shortages	\$0.10	\$0.48	\$0.87	\$0.81	\$0.78	\$0.78
Lost utility revenues	\$0.20	\$0.76	\$1.22	\$1.13	\$1.09	\$1.09
Uvalde						
Monetary value of domestic water shortages	\$28.56	\$28.86	\$29.03	\$29.06	\$29.08	\$29.31
Lost income from reduced commercial business activity	\$16.03	\$16.34	\$16.51	\$16.54	\$16.56	\$16.79
Lost jobs due to reduced commercial business activity	357	364	367	368	368	374
Lost state and local taxes from reduced commercial business activity	\$1.71	\$1.74	\$1.76	\$1.76	\$1.76	\$1.79
Lost utility revenues	\$5.70	\$5.77	\$5.81	\$5.81	\$5.82	\$5.87

Municipal (cont.)						
	2010	2020	2030	2040	2050	2060
Water Services Inc.						
Monetary value of domestic water shortages	\$21.86	\$27.55	\$33.22	\$38.38	\$43.22	\$48.43
Lost utility revenues	\$1.80	\$2.27	\$2.74	\$3.17	\$3.57	\$4.00
Wimberly						
Monetary value of domestic water shortages	\$0.36	\$2.79	\$5.26	\$7.91	\$14.28	\$17.07
Lost utility revenues	\$0.39	\$0.79	\$1.20	\$1.59	\$2.12	\$2.53
Windcrest						
Monetary value of domestic water shortages	\$0.30	\$0.29	\$0.28	\$0.27	\$0.26	\$0.27
Lost utility revenues	\$0.42	\$0.41	\$0.39	\$0.38	\$0.37	\$0.38
Woodcreek						
Monetary value of domestic water shortages	\$0.03	\$0.19	\$1.46	\$2.51	\$4.41	\$6.19
Lost utility revenues	\$0.05	\$0.18	\$0.32	\$0.45	\$0.63	\$0.77
Woodcreek Utilities Inc.						
Monetary value of domestic water shortages	\$6.33	\$19.35	\$30.50	\$40.34	\$52.42	\$61.92
Lost utility revenues	\$0.90	\$1.69	\$2.52	\$3.33	\$4.32	\$5.11
Yancey WSC						
Monetary value of domestic water shortages	\$0.31	\$0.00	\$0.00	\$7.01	\$8.28	\$9.54
Lost income from reduced commercial business activity	\$0.00	\$0.00	\$0.00	\$0.96	\$1.26	\$1.55
Lost jobs due to reduced commercial business activity	0	0	0	21	28	34
Lost state and local taxes from reduced commercial business activity	\$0.00	\$0.00	\$0.00	\$0.10	\$0.13	\$0.16
Lost utility revenues	\$0.42	\$0.78	\$1.11	\$1.41	\$1.69	\$1.95



TEXAS WATER DEVELOPMENT BOARD



James E. Herring, *Chairman*
Lewis H. McMahan, *Member*
Edward G. Vaughan, *Member*

J. Kevin Ward
Executive Administrator

Jack Hunt, *Vice Chairman*
Thomas Weir Labatt III, *Member*
Joe M. Crutcher, *Member*

June 15, 2010

Mr. Glenn Jarvis
Chairman, Rio Grande Regional Water Planning Group
c/o Law Offices of Glenn Jarvis
InterNational Bank
1801 South Second Street, Suite 550
McAllen, Texas 78503

Re: Socioeconomic Impact Analysis of Not Meeting Water Needs for the 2011 Rio Grande Regional Water Plan

Dear Chairman Jarvis:

We have received your request for technical assistance to complete the socioeconomic impact analysis of not meeting water needs. In response, enclosed is a report that describes our methodology and presents the results. Section 1 provides an overview of the methodology. Section 2 presents results at the regional level, and Appendix 2 show results for individual water user groups.

If you have any questions or comments, please feel free to contact me at (512) 463-7928 or by email at stuart.norvell@twdb.state.tx.us.

Sincerely,

Stuart D. Norvell
Manager, Water Planning Research and Analysis
Water Resources Planning Division

SN/ao

Enclosure

c. Connie Townsend, TWDB
S. Doug Shaw, TWDB

Our Mission

To provide leadership, planning, financial assistance, information, and education for the conservation and responsible development of water for Texas.

P.O. Box 13231 • 1700 N. Congress Avenue • Austin, Texas 78711-3231
Telephone (512) 463-7847 • Fax (512) 475-2053 • 1-800-RELAYTX (for the hearing impaired)
www.twdb.state.tx.us • info@twdb.state.tx.us

TNRIS - Texas Natural Resources Information System • www.tnr.is.state.tx.us
A Member of the Texas Geographic Information Council (TGIC)



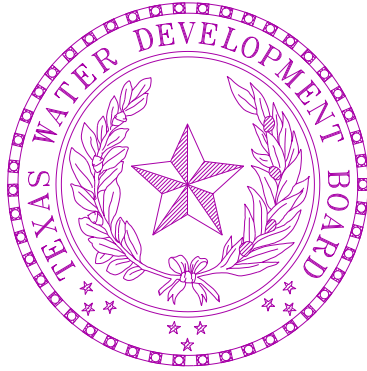

Socioeconomic Impacts of Projected Water Shortages for the Rio Grande Regional Water Planning Area (Region M)

Prepared in Support of the 2011 Rio Grande Regional Water Plan

Stuart D. Norvell, Managing Economist
Water Resources Planning Division
Texas Water Development Board
Austin, Texas

S. Doug Shaw, Agricultural Economist
Water Resources Planning Division
Texas Water Development Board
Austin, Texas

June 2010

Table of Contents

Section	Title	Page
	Introduction.....	3
1.0	Methodology.....	3
1.1	Economic Impacts of Water Shortages.....	3
1.1.1	General Approach.....	8
	General Assumptions and Clarifications of the Methodology.....	8
1.1.2	Impacts to Agriculture.....	9
	Irrigation.....	9
	Livestock.....	12
1.1.3	Impacts to Municipal Water User Groups.....	13
	Disaggregation of Municipal Water Demands.....	13
	Domestic Water Uses.....	14
	Commercial Businesses.....	17
	Water Utility Revenues.....	18
	Horticulture and Landscaping.....	18
	Recreational Impacts.....	19
1.1.4	Impacts to Industrial Water User Groups.....	19
	Manufacturing.....	20
	Mining.....	20
	Steam-electric.....	21
1.2	Social Impacts of Water Shortages.....	22
2.0	Results.....	22
2.1	Overview of Regional Economy.....	23
2.2	Impacts to Agricultural Water User Groups.....	24
2.3	Impacts to Municipal Water User Groups.....	25
2.4	Impacts to Manufacturing Water User Groups.....	26
2.5	Impacts to Steam-electric Water User Groups.....	26
2.6	Social Impacts.....	27
2.7	Distribution of Impacts by Major River Basin.....	27
	Appendix 1: Economic Data for Individual IMPLAN Sectors.....	28
	Appendix 2: Impacts by Water User Group.....	32
Tables		
1	Crop Classifications and Corresponding IMPLAN Crop Sectors.....	10
2	Summary of Irrigated Crop Acreage and Water Demand.....	10
3	Average Gross Sales Revenues per acre for Irrigated Crops.....	11
4	Description of Livestock Sectors.....	13
5	Water Use and Costs Parameters Used to Estimated Domestic Water Demand Functions.....	15
6	Economic Losses Associated with Domestic Water Shortages.....	17
7	Impacts of Municipal Water Shortages at Different Magnitudes of Shortages.....	20
8	Regional Baseline Economy by Water User Group.....	24
9	Economic Impacts of Water Shortages for Irrigation Water User Groups.....	24
10	Economic Impacts of Water Shortages for Municipal Water User Groups.....	25
11	Economic Impacts of Water Shortages for Manufacturing Water User Groups.....	26
12	Economic Impacts of Water Shortages for Steam-electric Water User Groups.....	26
13	Social Impacts of Water Shortages.....	28
14	Distribution of Impacts by Major River Basin.....	29

Introduction

Water shortages during drought would likely curtail or eliminate economic activity in business and industries reliant on water. For example, without water farmers cannot irrigate; refineries cannot produce gasoline, and paper mills cannot make paper. Unreliable water supplies would not only have an immediate and real impact on existing businesses and industry, but they could also adversely affect economic development in Texas. From a social perspective, water supply reliability is critical as well. Shortages would disrupt activity in homes, schools and government and could adversely affect public health and safety. For all of the above reasons, it is important to analyze and understand how restricted water supplies during drought could affect communities throughout the state.

Administrative rules require that regional water planning groups evaluate the impacts of not meeting water needs as part of the regional water planning process, and rules direct TWDB staff to provide technical assistance: *“The executive administrator shall provide available technical assistance to the regional water planning groups, upon request, on water supply and demand analysis, including methods to evaluate the social and economic impacts of not meeting needs”* [(§357.7 (4)(A)]. Staff of the TWDB’s Water Resources Planning Division designed and conducted this report in support of the Rio Grande Regional Water Planning Group (Region M).

This document summarizes the results of our analysis and discusses the methodology used to generate the results. Section 1 outlines the overall methodology and discusses approaches and assumptions specific to each water use category (i.e., irrigation, livestock, mining, steam-electric, municipal and manufacturing). Section 2 presents the results for each category where shortages are reported at the regional planning area level and river basin level. Results for individual water user groups are not presented, but are available upon request.

1. Methodology

Section 1 provides a general overview of how economic and social impacts were measured. In addition, it summarizes important clarifications, assumptions and limitations of the study.

1.1 Economic Impacts of Water Shortages

1.1.1 General Approach

Economic analysis as it relates to water resources planning generally falls into two broad areas. Supply side analysis focuses on costs and alternatives of developing new water supplies or implementing programs that provide additional water from current supplies. Demand side analysis concentrates on impacts or benefits of providing water to people, businesses and the environment. Analysis in this report focuses strictly on demand side impacts. When analyzing the economic impacts of water shortages as defined in Texas water planning, three potential scenarios are possible:

- 1) Scenario 1 involves situations where there are physical shortages of raw surface or groundwater due to drought of record conditions. For example, City A relies on a reservoir with average conservation storage of 500 acre-feet per year and a firm yield of 100 acre feet. In 2010, the city uses about 50 acre-feet per year, but by 2030 their demands are expected to increase to 200 acre-feet. Thus, in 2030 the reservoir would not have enough water to meet the city’s demands,

and people would experience a shortage of 100 acre-feet assuming drought of record conditions. Under normal or average climatic conditions, the reservoir would likely be able to provide reliable water supplies well beyond 2030.

- 2) Scenario 2 is a situation where despite drought of record conditions, water supply sources can meet existing use requirements; however, limitations in water infrastructure would preclude future water user groups from accessing these water supplies. For example, City B relies on a river that can provide 500 acre-feet per year during drought of record conditions and other constraints as dictated by planning assumptions. In 2010, the city is expected to use an estimated 100 acre-feet per year and by 2060 it would require no more than 400 acre-feet. But the intake and pipeline that currently transfers water from the river to the city's treatment plant has a capacity of only 200 acre-feet of water per year. Thus, the city's water supplies are adequate even under the most restrictive planning assumptions, but their conveyance system is too small. This implies that at some point – perhaps around 2030 - infrastructure limitations would constrain future population growth and any associated economic activity or impacts.
- 3) Scenario 3 involves water user groups that rely primarily on aquifers that are being depleted. In this scenario, projected and in some cases existing demands may be unsustainable as groundwater levels decline. Areas that rely on the Ogallala aquifer are a good example. In some communities in the region, irrigated agriculture forms a major base of the regional economy. With less irrigation water from the Ogallala, population and economic activity in the region could decline significantly assuming there are no offsetting developments.

Assessing the social and economic effects of each of the above scenarios requires various levels and methods of analysis and would generate substantially different results for a number of reasons; the most important of which has to do with the time frame of each scenario. Scenario 1 falls into the general category of static analysis. This means that models would measure impacts for a small interval of time such as a drought. Scenarios 2 and 3, on the other hand imply a dynamic analysis meaning that models are concerned with changes over a much longer time period.

Since administrative rules specify that planning analysis be evaluated under drought of record conditions (a static and random event), socioeconomic impact analysis developed by the TWDB for the state water plan is based on assumptions of Scenario 1. Estimated impacts under scenario 1 are point estimates for years in which needs are reported (2010, 2020, 2030, 2040, 2050 and 2060). They are independent and distinct “what if” scenarios for a particular year and shortages are assumed to be temporary events resulting from drought of record conditions. Estimated impacts measure what would happen if water user groups experience water shortages for a period of one year.

The TWDB recognize that dynamic models may be more appropriate for some water user groups; however, combining approaches on a statewide basis poses several problems. For one, it would require a complex array of analyses and models, and might require developing supply and demand forecasts under “normal” climatic conditions as opposed to drought of record conditions. Equally important is the notion that combining the approaches would produce inconsistent results across regions resulting in a so-called “apples to oranges” comparison.

A variety tools are available to estimate economic impacts, but by far, the most widely used today are input-output models (IO models) combined with social accounting matrices (SAMs). Referred to as IO/SAM models, these tools formed the basis for estimating economic impacts for agriculture (irrigation and livestock water uses) and industry (manufacturing, mining, steam-electric and commercial business activity for municipal water uses).

Since the planning horizon extends through 2060, economic variables in the baseline are adjusted in accordance with projected changes in demographic and economic activity. Growth rates for municipal water use sectors (i.e., commercial, residential and institutional) are based on TWDB population forecasts. Future values for manufacturing, agriculture, and mining and steam-electric activity are based on the same underlying economic forecasts used to estimate future water use for each category.

The following steps outline the overall process.

Step 1: Generate IO/SAM Models and Develop Economic Baseline

IO/SAM models were estimated using propriety software known as IMPLAN PRO™ (Impact for Planning Analysis). IMPLAN is a modeling system originally developed by the U.S. Forestry Service in the late 1970s. Today, the Minnesota IMPLAN Group (MIG Inc.) owns the copyright and distributes data and software. It is probably the most widely used economic impact model in existence. IMPLAN comes with databases containing the most recently available economic data from a variety of sources.¹ Using IMPLAN software and data, transaction tables conceptually similar to the one discussed previously were estimated for each county in the region and for the region as a whole. Each transaction table contains 528 economic sectors and allows one to estimate a variety of economic statistics including:

- **total sales** - total production measured by sales revenues;
- **intermediate sales** - sales to other businesses and industries within a given region;
- **final sales** – sales to end users in a region and exports out of a region;
- **employment** - number of full and part-time jobs (annual average) required by a given industry including self-employment;
- **regional income** - total payroll costs (wages and salaries plus benefits) paid by industries, corporate income, rental income and interest payments; and
- **business taxes** - sales, excise, fees, licenses and other taxes paid during normal operation of an industry (does not include income taxes).

TWDB analysts developed an economic baseline containing each of the above variables using year 2000 data. Since the planning horizon extends through 2060, economic variables in the baseline were allowed to change in accordance with projected changes in demographic and economic activity. Growth rates for municipal water use sectors (i.e., commercial, residential and institutional) are based on TWDB population forecasts. Projections for manufacturing, agriculture, and mining and steam-electric activity are based on the same underlying economic forecasts used to estimate future water use for each category. Monetary impacts in future years are reported in constant year 2006 dollars.

It is important to stress that employment, income and business taxes are the most useful variables when comparing the relative contribution of an economic sector to a regional economy. Total sales as reported in IO/SAM models are less desirable and can be misleading because they include sales to other industries in the region for use in the production of other goods. For example, if a mill buys grain from local farmers and uses it to produce feed, sales of both the processed feed and raw corn are counted as “output” in an IO model. Thus, total sales double-count or overstate the true economic value of goods

¹The IMPLAN database consists of national level technology matrices based on benchmark input-output accounts generated by the U.S. Bureau of Economic Analysis and estimates of final demand, final payments, industry output and employment for various economic sectors. IMPLAN regional data (i.e. states, a counties or groups of counties within a state) are divided into two basic categories: 1) data on an industry basis including value-added, output and employment, and 2) data on a commodity basis including final demands and institutional sales. State-level data are balanced to national totals using a matrix ratio allocation system and county data are balanced to state totals.

and services produced in an economy. They are not consistent with commonly used measures of output such as Gross National Product (GNP), which counts only final sales.

Another important distinction relates to terminology. Throughout this report, the term *sector* refers to economic subdivisions used in the IMPLAN database and resultant input-output models (528 individual sectors based on Standard Industrial Classification Codes). In contrast, the phrase *water use category* refers to water user groups employed in state and regional water planning including irrigation, livestock, mining, municipal, manufacturing and steam electric. Each IMPLAN sector was assigned to a specific water use category.

Step 2: Estimate Direct and Indirect Economic Impacts of Water Needs

Direct impacts are reductions in output by sectors experiencing water shortages. For example, without adequate cooling and process water a refinery would have to curtail or cease operation, car washes may close, or farmers may not be able to irrigate and sales revenues fall. Indirect impacts involve changes in inter-industry transactions as supplying industries respond to decreased demands for their services, and how seemingly non-related businesses are affected by decreased incomes and spending due to direct impacts. For example, if a farmer ceases operations due to a lack of irrigation water, they would likely reduce expenditures on supplies such as fertilizer, labor and equipment, and businesses that provide these goods would suffer as well.

Direct impacts accrue to immediate businesses and industries that rely on water and without water industrial processes could suffer. However, output responses may vary depending upon the severity of shortages. A small shortage relative to total water use would likely have a minimal impact, but large shortages could be critical. For example, farmers facing small shortages might fallow marginally productive acreage to save water for more valuable crops. Livestock producers might employ emergency culling strategies, or they may consider hauling water by truck to fill stock tanks. In the case of manufacturing, a good example occurred in the summer of 1999 when Toyota Motor Manufacturing experienced water shortages at a facility near Georgetown, Kentucky.² As water levels in the Kentucky River fell to historic lows due to drought, plant managers sought ways to curtail water use such as reducing rinse operations to a bare minimum and recycling water by funneling it from paint shops to boilers. They even considered trucking in water at a cost of 10 times what they were paying. Fortunately, rains at the end of the summer restored river levels, and Toyota managed to implement cutbacks without affecting production, but it was a close call. If rains had not replenished the river, shortages could have severely reduced output.³

To account for uncertainty regarding the relative magnitude of impacts to farm and business operations, the following analysis employs the concept of elasticity. Elasticity is a number that shows how a change in one variable will affect another. In this case, it measures the relationship between a percentage reduction in water availability and a percentage reduction in output. For example, an elasticity of 1.0 indicates that a 1.0 percent reduction in water availability would result in a 1.0 percent reduction in economic output. An elasticity of 0.50 would indicate that for every 1.0 percent of unavailable water, output is reduced by 0.50 percent and so on. Output elasticities used in this study are:⁴

² Royal, W. "High And Dry - Industrial Centers Face Water Shortages." in Industry Week, Sept, 2000.

³ The efforts described above are not planned programmatic or long-term operational changes. They are emergency measures that individuals might pursue to alleviate what they consider a temporary condition. Thus, they are not characteristic of long-term management strategies designed to ensure more dependable water supplies such as capital investments in conservation technology or development of new water supplies.

⁴ Elasticities are based on one of the few empirical studies that analyze potential relationships between economic output and water shortages in the United States. The study, conducted in California, showed that a significant number of industries would suffer reduced output during water shortages. Using a survey based approach researchers posed two scenarios to different industries. In

- if water needs are 0 to 5 percent of total water demand, no corresponding reduction in output is assumed;
- if water needs are 5 to 30 percent of total water demand, for each additional one percent of water need that is not met, there is a corresponding 0.50 percent reduction in output;
- if water needs are 30 to 50 percent of total water demand, for each additional one percent of water need that is not met, there is a corresponding 0.75 percent reduction in output; and
- if water needs are greater than 50 percent of total water demand, for each additional one percent of water need that is not met, there is a corresponding 1.0 percent (i.e., a proportional reduction).

In some cases, elasticities are adjusted depending upon conditions specific to a given water user group.

Once output responses to water shortages were estimated, direct impacts to total sales, employment, regional income and business taxes were derived using regional level economic multipliers estimating using IO/SAM models. The formula for a given IMPLAN sector is:

$$D_{i,t} = Q_{i,t} * S_{i,t} * E_Q * RFD_i * DM_{i(Q,L,I,T)}$$

where:

$D_{i,t}$ = direct economic impact to sector i in period t

$Q_{i,t}$ = total sales for sector i in period t in an affected county

RFD_i = ratio of final demand to total sales for sector i for a given region

$S_{i,t}$ = water shortage as percentage of total water use in period t

E_Q = elasticity of output and water use

$DM_{i(L,I,T)}$ = direct output multiplier coefficients for labor (L), income (I) and taxes (T) for sector i .

Secondary impacts were derived using the same formula used to estimate direct impacts; however, indirect multiplier coefficients are used. Methods and assumptions specific to each water use sector are discussed in Sections 1.1.2 through 1.1.4.

the first scenario, they asked how a 15 percent cutback in water supply lasting one year would affect operations. In the second scenario, they asked how a 30 percent reduction lasting one year would affect plant operations. In the case of a 15 percent shortage, reported output elasticities ranged from 0.00 to 0.76 with an average value of 0.25. For a 30 percent shortage, elasticities ranged from 0.00 to 1.39 with average of 0.47. For further information, see, California Urban Water Agencies, "Cost of Industrial Water Shortages," Spectrum Economics, Inc. November, 1991.

General Assumptions and Clarification of the Methodology

As with any attempt to measure and quantify human activities at a societal level, assumptions are necessary and every model has limitations. Assumptions are needed to maintain a level of generality and simplicity such that models can be applied on several geographic levels and across different economic sectors. In terms of the general approach used here several clarifications and cautions are warranted:

1. Shortages as reported by regional planning groups are the starting point for socioeconomic analyses.
2. Estimated impacts are point estimates for years in which needs are reported (i.e., 2010, 2020, 2030, 2040, 2050 and 2060). They are independent and distinct “what if” scenarios for each particular year and water shortages are assumed to be temporary events resulting from severe drought conditions combined with infrastructure limitations. In other words, growth occurs and future shocks are imposed on an economy at 10-year intervals and resultant impacts are measured. Given that reported figures are not cumulative in nature, it is inappropriate to sum impacts over the entire planning horizon. Doing so, would imply that the analysis predicts that drought of record conditions will occur every ten years in the future, which is not the case. Similarly, authors of this report recognize that in many communities needs are driven by population growth, and in the future total population will exceed the amount of water available due to infrastructure limitations, regardless of whether or not there is a drought. This implies that infrastructure limitations would constrain economic growth. However, since needs as defined by planning rules are based upon water supply and demand under the assumption of drought of record conditions, it is improper to conduct economic analysis that focuses on growth related impacts over the planning horizon. Figures generated from such an analysis would presume a 50-year drought of record, which is unrealistic. Estimating lost economic activity related to constraints on population and commercial growth due to lack of water would require developing water supply and demand forecasts under “normal” or “most likely” future climatic conditions.
3. While useful for planning purposes, this study is not a benefit-cost analysis. Benefit cost analysis is a tool widely used to evaluate the economic feasibility of specific policies or projects as opposed to estimating economic impacts of unmet water needs. Nevertheless, one could include some impacts measured in this study as part of a benefit cost study if done so properly. Since this is not a benefit cost analysis, future impacts are not weighted differently. In other words, estimates are not discounted. If used as a measure of economic benefits, one should incorporate a measure of uncertainty into the analysis. In this type of analysis, a typical method of discounting future values is to assign probabilities of the drought of record recurring again in a given year, and weight monetary impacts accordingly. This analysis assumes a probability of one.
4. IO multipliers measure the strength of backward linkages to supporting industries (i.e., those who sell inputs to an affected sector). However, multipliers say nothing about forward linkages consisting of businesses that purchase goods from an affected sector for further processing. For example, ranchers in many areas sell most of their animals to local meat packers who process animals into a form that consumers ultimately see in grocery stores and restaurants. Multipliers do not capture forward linkages to meat packers, and since meat packers sell livestock purchased from ranchers as “final sales,” multipliers for the ranching sector do not fully account for all losses to a region’s economy. Thus, as mentioned previously, in some cases closely linked sectors were moved from one water use category to another.
5. Cautions regarding interpretations of direct and secondary impacts are warranted. IO/SAM multipliers are based on “fixed-proportion production functions,” which basically means that input use - including labor - moves in lockstep fashion with changes in levels of output. In a

scenario where output (i.e., sales) declines, losses in the immediate sector or supporting sectors could be much less than predicted by an IO/SAM model for several reasons. For one, businesses will likely expect to continue operating so they might maintain spending on inputs for future use; or they may be under contractual obligations to purchase inputs for an extended period regardless of external conditions. Also, employers may not lay-off workers given that experienced labor is sometimes scarce and skilled personnel may not be readily available when water shortages subside. Lastly people who lose jobs might find other employment in the region. As a result, direct losses for employment and secondary losses in sales and employment should be considered an upper bound. Similarly, since projected population losses are based on reduced employment in the region, they should be considered an upper bound as well.

6. IO models are static. Models and resultant multipliers are based upon the structure of the U.S. and regional economies in 2006. In contrast, water shortages are projected to occur well into the future. Thus, the analysis assumes that the general structure of the economy remains the same over the planning horizon, and the farther out into the future we go, this assumption becomes less reliable.
7. Impacts are annual estimates. If one were to assume that conditions persisted for more than one year, figures should be adjusted to reflect the extended duration. The drought of record in most regions of Texas lasted several years.
8. Monetary figures are reported in constant year 2006 dollars.

1.1.2 Impacts to Agriculture

Irrigated Crop Production

The first step in estimating impacts to irrigation required calculating gross sales for IMPLAN crop sectors. Default IMPLAN data do not distinguish irrigated production from dry-land production. Once gross sales were known other statistics such as employment and income were derived using IMPLAN direct multiplier coefficients. Gross sales for a given crop are based on two data sources:

- 1) county-level statistics collected and maintained by the TWDB and the USDA Farm Services Agency (FSA) including the number of irrigated acres by crop type and water application per acre, and
- 2) regional-level data published by the Texas Agricultural Statistics Service (TASS) including prices received for crops (marketing year averages), crop yields and crop acreages.

Crop categories used by the TWDB differ from those used in IMPLAN datasets. To maintain consistency, sales and other statistics are reported using IMPLAN crop classifications. Table 1 shows the TWDB crops included in corresponding IMPLAN sectors, and Table 2 summarizes acreage and estimated annual water use for each crop classification (five-year average from 2003-2007). Table 3 displays average (2003-2007) gross revenues per acre for IMPLAN crop categories.

Table 1: Crop Classifications Used in TWDB Water Use Survey and Corresponding IMPLAN Crop Sectors	
IMPLAN Category	TWDB Category
Oilseeds	Soybeans and "other oil crops"
Grains	Grain sorghum, corn, wheat and "other grain crops"
Vegetable and melons	"Vegetables" and potatoes
Tree nuts	Pecans
Fruits	Citrus, vineyard and other orchard
Cotton	Cotton
Sugarcane and sugar beets	Sugarcane and sugar beets
All "other" crops	"Forage crops", peanuts, alfalfa, hay and pasture, rice and "all other crops"

Table 2: Summary of Irrigated Crop Acreage and Water Demand for the Rio Grande Regional Water Planning Area (average 2003-2007)					
Sector	Acres (1000s)	Distribution of acres	Water use (1000s of AF)	Distribution of water use	
Oilseeds	4	1%	5	1%	
Grains	143	31%	253	27%	
Vegetable and melons	73	16%	120	13%	
Tree nuts	7	1%	18	2%	
Fruits	13	3%	34	4%	
Cotton	59	13%	111	12%	
Sugarcane	42	9%	142	15%	
All other crops	120	26%	252	27%	
Total	459	100%	937	100%	

Source: Water demand figures are a 5- year average (2003-2007) of the TWDB's annual Irrigation Water Use Estimates. Statistics for irrigated crop acreage are based upon annual survey data collected by the TWDB and the Farm Service Agency. Values do not include acreage or water use for the TWDB categories classified by the Farm Services Agency as "failed acres," "golf course" or "waste water."

Table 3: Average Gross Sales Revenues per Acre for Irrigated Crops for the Rio Grande Regional Water Planning Area (2003-2007)

IMPLAN Sector	Gross revenues per acre	Crops included in estimates
Grains	\$267	Based on five-year (2003-2007) average weighted by acreage for "irrigated grain sorghum," "irrigated corn," "irrigated wheat" and "irrigated 'other' grain crops."
Oilseed Farming	\$214	Irrigated figure is based on five-year (2003-2007) average weighted by acreage for "irrigated soybeans" and "irrigated 'other' oil crops."
Vegetable and melons	\$6,246	Based on five-year (2003-2007) average weighted by acreage for "irrigated shallow and deep root vegetables", "irrigated Irish potatoes" and "irrigated melons."
Tree nuts	\$3,304	Based on five-year (2003-2007) average weighted by acreage for "irrigated pecans."
Fruits	6,305	Based on five-year (2003-2007) average weighted by acreage for "irrigated citrus", "irrigated vineyards" and "irrigated 'other' orchard."
Cotton	\$389	Based on five-year (2003-2007) average weighted by acreage for "irrigated cotton."
Sugarcane	\$1,051	Based on five-year (2003-2007) average weighted by acreage for irrigated sugarcane.
All other crops	\$254	Irrigated figure is based on five-year (2003-2007) average weighted by acreage for "irrigated 'forage' crops", "irrigated peanuts", "irrigated alfalfa", "irrigated 'hay' and pasture" and "irrigated 'all other' crops."

*Figures are rounded. Source: Based on data from the Texas Agricultural Statistics Service, Texas Water Development Board, and Texas A&M University.

An important consideration when estimating impacts to irrigation was determining which crops are affected by water shortages. One approach is the so-called rationing model, which assumes that farmers respond to water supply cutbacks by following the lowest value crops in the region first and the highest valued crops last until the amount of water saved equals the shortage.⁵ For example, if farmer A grows vegetables (higher value) and farmer B grows wheat (lower value) and they both face a proportionate cutback in irrigation water, then farmer B will sell water to farmer A. Farmer B will follow her irrigated acreage before farmer A follows anything. Of course, this assumes that farmers can and do transfer enough water to allow this to happen. A different approach involves constructing farm-level profit maximization models that conform to widely-accepted economic theory that farmers make decisions based on marginal net returns. Such models have good predictive capability, but data requirements and complexity are high. Given that a detailed analysis for each region would require a substantial amount of farm-level data and analysis, the following investigation assumes that projected shortages are distributed equally across predominant crops in the region. Predominant in this case are crops that comprise at least one percent of total acreage in the region.

The following steps outline the overall process used to estimate direct impacts to irrigated agriculture:

1. *Distribute shortages across predominant crop types in the region.* Again, unmet water needs were distributed equally across crop sectors that constitute one percent or more of irrigated acreage.
2. *Estimate associated reductions in output for affected crop sectors.* Output reductions are based on elasticities discussed previously and on estimated values per acre for different crops. Values per acre stem from the same data used to estimate output for the year 2006 baseline. Using multipliers, we then generate estimates of forgone income, jobs, and tax revenues based on reductions in gross sales and final demand.

Livestock

The approach used for the livestock sector is basically the same as that used for crop production. As is the case with crops, livestock categorizations used by the TWDB differ from those used in IMPLAN datasets, and TWDB groupings were assigned to a given IMPLAN sector (Table 4). Then we:

- 1) *Distribute projected water needs equally among predominant livestock sectors and estimate lost output:* As is the case with irrigation, shortages are assumed to affect all livestock sectors equally; however, the category of “other” is not included given its small size. If water needs were small relative to total demands, we assume that producers would haul in water by truck to fill stock tanks. The cost per acre-foot (\$24,000) is based on 2008 rates charged by various water haulers in Texas, and assumes that the average truck load is 6,500 gallons at a hauling distance of 60 miles.
- 3) *Estimate reduced output in forward processors for livestock sectors.* Reductions in output for livestock sectors are assumed to have a proportional impact on forward processors in the region such as meat packers. In other words, if the cows were gone, meat-packing plants or fluid milk manufacturers would likely have little to process. This is not an unreasonable premise. Since the

⁵ The rationing model was initially proposed by researchers at the University of California at Berkeley, and was then modified for use in a study conducted by the U.S. Environmental Protection Agency that evaluated how proposed water supply cutbacks recommended to protect water quality in the Bay/Delta complex in California would affect farmers in the Central Valley. See, Zilberman, D., Howitt, R. and Sunding, D. “*Economic Impacts of Water Quality Regulations in the San Francisco Bay and Delta.*” Western Consortium for Public Health. May 1993.

1950s, there has been a major trend towards specialized cattle feedlots, which in turn has decentralized cattle purchasing from livestock terminal markets to direct sales between producers and slaughterhouses. Today, the meat packing industry often operates large processing facilities near high concentrations of feedlots to increase capacity utilization.⁶ As a result, packers are heavily dependent upon nearby feedlots. For example, a recent study by the USDA shows that on average meat packers obtain 64 percent of cattle from within 75 miles of their plant, 82 percent from within 150 miles and 92 percent from within 250 miles.⁷

Table 4: Description of Livestock Sectors	
IMPLAN Category	TWDB Category
Cattle ranching and farming	Cattle, cow calf, feedlots and dairies
Poultry and egg production	Poultry production.
Other livestock	Livestock other than cattle and poultry (i.e., horses, goats, sheep, hogs)
Milk manufacturing	Fluid milk manufacturing, cheese manufacturing, ice cream manufacturing etc.
Meat packing	Meat processing present in the region from slaughter to final processing

1.1.3 Impacts to Municipal Water User Groups

Disaggregation of Municipal Water Demands

Estimating the economic impacts for the municipal water user groups is complicated for a number of reasons. For one, municipal use comprises a range of consumers including commercial businesses, institutions such as schools and government and households. However, reported water needs are not distributed among different municipal water users. In other words, how much of a municipal need is commercial and how much is residential (domestic)?

The amount of commercial water use as a percentage of total municipal demand was estimated based on “GED” coefficients (gallons per employee per day) published in secondary sources.⁸ For example, if year 2006 baseline data for a given economic sector (e.g., amusement and recreation services) shows employment at 30 jobs and the GED coefficient is 200, then average daily water use by that sector is (30 x

⁶ Ferreira, W.N. “*Analysis of the Meat Processing Industry in the United States.*” Clemson University Extension Economics Report ER211, January 2003.

⁷ Ward, C.E. “*Summary of Results from USDA’s Meatpacking Concentration Study.*” Oklahoma Cooperative Extension Service, OSU Extension Facts WF-562.

⁸ Sources for GED coefficients include: Gleick, P.H., Haasz, D., Henges-Jeck, C., Srinivasan, V., Wolff, G. Cushing, K.K., and Mann, A. “*Waste Not, Want Not: The Potential for Urban Water Conservation in California.*” Pacific Institute. November 2003. U.S. Bureau of the Census. 1982 Census of Manufacturers: Water Use in Manufacturing. USGPO, Washington D.C. See also: “*U.S. Army Engineer Institute for Water Resources, IWR Report 88-R-6.*,” Fort Belvoir, VA. See also, Joseph, E. S., 1982, “*Municipal and Industrial Water Demands of the Western United States.*” Journal of the Water Resources Planning and Management Division, Proceedings of the American Society of Civil Engineers, v. 108, no. WR2, p. 204-216. See also, Baumann, D. D., Boland, J. J., and Sims, J. H., 1981, “*Evaluation of Water Conservation for Municipal and Industrial Water Supply.*” U.S. Army Corps of Engineers, Institute for Water Resources, Contract no. 82-C1.

200 = 6,000 gallons) or 6.7 acre-feet per year. Water not attributed to commercial use is considered domestic, which includes single and multi-family residential consumption, institutional uses and all use designated as “county-other.” Based on our analysis, commercial water use is about 5 to 35 percent of municipal demand. Less populated rural counties occupy the lower end of the spectrum, while larger metropolitan counties are at the higher end.

After determining the distribution of domestic versus commercial water use, we developed methods for estimating impacts to the two groups.

Domestic Water Uses

Input output models are not well suited for measuring impacts of shortages for domestic water uses, which make up the majority of the municipal water use category. To estimate impacts associated with domestic water uses, municipal water demand and needs are subdivided into residential, and commercial and institutional use. Shortages associated with residential water uses are valued by estimating proxy demand functions for different water user groups allowing us to estimate the marginal value of water, which would vary depending upon the level of water shortages. The more severe the water shortage, the more costly it becomes. For instance, a 2 acre-foot shortage for a group of households that use 10 acre-feet per year would not be as severe as a shortage that amounted to 8 acre-feet. In the case of a 2 acre-foot shortage, households would probably have to eliminate some or all outdoor water use, which could have implicit and explicit economic costs including losses to the horticultural and landscaping industry. In the case of an 8 acre-foot shortage, people would have to forgo all outdoor water use and most indoor water consumption. Economic impacts would be much higher in the latter case because people, and would be forced to find emergency alternatives assuming alternatives were available.

To estimate the value of domestic water uses, TWDB staff developed marginal loss functions based on constant elasticity demand curves. This is a standard and well-established method used by economists to value resources such as water that have an explicit monetary cost.

A constant price elasticity of demand is estimated using a standard equation:

$$w = kc^{(-\epsilon)}$$

where:

- w is equal to average monthly residential water use for a given water user group measured in thousands of gallons;
- k is a constant intercept;
- c is the average cost of water per 1,000 gallons; and
- ϵ is the price elasticity of demand.

Price elasticities (-0.30 for indoor water use and -0.50 for outdoor use) are based on a study by Bell et al.⁹ that surveyed 1,400 water utilities in Texas that serve at least 1,000 people to estimate demand elasticity for several variables including price, income, weather etc. Costs of water and average use per month per household are based on data from the Texas Municipal League's annual water and

⁹ Bell, D.R. and Griffin, R.C. “Community Water Demand in Texas as a Century is Turned.” Research contract report prepared for the Texas Water Development Board. May 2006.

wastewater rate surveys - specifically average monthly household expenditures on water and wastewater in different communities across the state. After examining variance in costs and usage, three different categories of water user groups based on population (population less than 5,000, cities with populations ranging from 5,000 to 99,999 and cities with populations exceeding 100,000) were selected to serve as proxy values for municipal water groups that meet the criteria (Table 5).¹⁰

Table 5: Water Use and Costs Parameters Used to Estimated Water Demand Functions (average monthly costs per acre-foot for delivered water and average monthly use per household)				
Community Population	Water	Wastewater	Total monthly cost	Avg. monthly use (gallons)
Less than or equal to 5,000	\$1,335	\$1,228	\$2,563	6,204
5,000 to 100,000	\$1,047	\$1,162	\$2,209	7,950
Great than or equal to 100,000	\$718	\$457	\$1,190	8,409

Source: Based on annual water and wastewater rate surveys published by the Texas Municipal League.

As an example, Table 6 shows the economic impact per acre-foot of domestic water needs for municipal water user groups with population exceeding 100,000 people. There are several important assumptions incorporated in the calculations:

- 1) Reported values are net of the variable costs of treatment and distribution such as expenses for chemicals and electricity since using less water involves some savings to consumers and utilities alike; and for outdoor uses we do not include any value for wastewater.
- 2) Outdoor and “non-essential” water uses would be eliminated before indoor water consumption was affected, which is logical because most water utilities in Texas have drought contingency plans that generally specify curtailment or elimination of outdoor water use during droughts.¹¹ Determining how much water is used for outdoor purposes is based on several secondary sources. The first is a major study sponsored by the American Water Works Association, which surveyed cities in states including Colorado, Oregon, Washington, California, Florida and Arizona. On average across all cities surveyed 58 percent of single family residential water use was for outdoor activities. In cities with climates comparable to large metropolitan areas of Texas, the average was 40 percent.¹² Earlier findings of the U.S. Water Resources Council showed a national

¹⁰ Ideally, one would want to estimate demand functions for each individual utility in the state. However, this would require an enormous amount of time and resources. For planning purposes, we believe the values generated from aggregate data are more than sufficient.

¹¹ In Texas, state law requires retail and wholesale water providers to prepare and submit plans to the Texas Commission on Environmental Quality (TCEQ). Plans must specify demand management measures for use during drought including curtailment of “non-essential water uses.” Non-essential uses include, but are not limited to, landscape irrigation and water for swimming pools or fountains. For further information see the Texas Environmental Quality Code §288.20.

¹² See, Mayer, P.W., DeOreo, W.B., Opitz, E.M., Kiefer, J.C., Davis, W., Dziegielewski, D., Nelson, J.O. “Residential End Uses of Water.” Research sponsored by the American Water Works Association and completed by Aquacraft, Inc. and Planning and Management Consultants, Ltd. (PMCL@CDM).

average of 33 percent. Similarly, the United States Environmental Protection Agency (USEPA) estimated that landscape watering accounts for 32 percent of total residential and commercial water use on annual basis.¹³ A study conducted for the California Urban Water Agencies (CUWA) calculated average annual values ranging from 25 to 35 percent.¹⁴ Unfortunately, there does not appear to be any comprehensive research that has estimated non-agricultural outdoor water use in Texas. As an approximation, an average annual value of 30 percent based on the above references was selected to serve as a rough estimate in this study.

3) As shortages approach 100 percent values become immense and theoretically infinite at 100 percent because at that point death would result, and willingness to pay for water is immeasurable. Thus, as shortages approach 80 percent of monthly consumption, we assume that households and non-water intensive commercial businesses (those that use water only for drinking and sanitation would have water delivered by tanker truck or commercial water delivery companies. Based on reports from water companies throughout the state, we estimate that the cost of trucking in water is around \$21,000 to \$27,000 per acre-feet assuming a hauling distance of between 20 to 60 miles. This is not an unreasonable assumption. The practice was widespread during the 1950s drought and recently during droughts in this decade. For example, in 2000 at the heels of three consecutive drought years Electra - a small town in North Texas - was down to its last 45 days worth of reservoir water when rain replenished the lake, and the city was able to refurbish old wells to provide supplemental groundwater. At the time, residents were forced to limit water use to 1,000 gallons per person per month - less than half of what most people use - and many were having water delivered to their homes by private contractors.¹⁵ In 2003 citizens of Ballinger, Texas, were also faced with a dwindling water supply due to prolonged drought. After three years of drought, Lake Ballinger, which supplies water to more than 4,300 residents in Ballinger and to 600 residents in nearby Rowena, was almost dry. Each day, people lined up to get water from a well in nearby City Park. Trucks hauling trailers outfitted with large plastic and metal tanks hauled water to and from City Park to Ballinger.¹⁶

¹³ U.S. Environmental Protection Agency. *"Cleaner Water through Conservation."* USEPA Report no. 841-B-95-002. April, 1995.

¹⁴ Planning and Management Consultants, Ltd. *"Evaluating Urban Water Conservation Programs: A Procedures Manual."* Prepared for the California Urban Water Agencies. February 1992.

¹⁵ Zewe, C. *"Tap Threatens to Run Dry in Texas Town."* July 11, 2000. CNN Cable News Network.

¹⁶ Associated Press, *"Ballinger Scrambles to Finish Pipeline before Lake Dries Up."* May 19, 2003.

Table 6: Economic Losses Associated with Domestic Water Shortages in Communities with Populations Exceeding 100,000 people

Water shortages as a percentage of total monthly household demands	No. of gallons remaining per household per day	No of gallons remaining per person per day	Economic loss (per acre-foot)		Economic loss (per gallon)	
1%	278	93	\$748		\$0.00005	
5%	266	89	\$812		\$0.0002	
10%	252	84	\$900		\$0.0005	
15%	238	79	\$999		\$0.0008	
20%	224	75	\$1,110		\$0.0012	
25%	210	70	\$1,235		\$0.0015	
30% ^a	196	65	\$1,699		\$0.0020	
35%	182	61	\$3,825		\$0.0085	
40%	168	56	\$4,181		\$0.0096	
45%	154	51	\$4,603		\$0.011	
50%	140	47	\$5,109		\$0.012	
55%	126	42	\$5,727		\$0.014	
60%	112	37	\$6,500		\$0.017	
65%	98	33	\$7,493		\$0.02	
70%	84	28	\$8,818		\$0.02	
75%	70	23	\$10,672		\$0.03	
80%	56	19	\$13,454		\$0.04	
85%	42	14	\$18,091	(\$24,000) ^b	\$0.05	(\$0.07) ^b
90%	28	9	\$27,363	(\$24,000)	\$0.08	(\$0.07)
95%	14	5	\$55,182	(\$24,000)	\$0.17	(\$0.07)
99%	3	0.9	\$277,728	(\$24,000)	\$0.85	(\$0.07)
99.9%	1	0.5	\$2,781,377	(\$24,000)	\$8.53	(\$0.07)
100%	0	0	Infinite	(\$24,000)	Infinite	(\$0.07)

^a The first 30 percent of needs are assumed to be restrictions of outdoor water use; when needs reach 30 percent of total demands all outdoor water uses would be restricted. Needs greater than 30 percent include indoor use

^b As shortages approach 100 percent the value approaches infinity assuming there are not alternatives available; however, we assume that communities would begin to have water delivered by tanker truck at an estimated cost of \$24,000 per acre-foot when shortages breached 85 percent.

Commercial Businesses

Effects of water shortages on commercial sectors were estimated in a fashion similar to other business sectors meaning that water shortages would affect the ability of these businesses to operate. This is particularly true for “water intensive” commercial sectors that are need large amounts of water (in addition to potable and sanitary water) to provide their services. These include:

- car-washes,
- laundry and cleaning facilities,
- sports and recreation clubs and facilities including race tracks,
- amusement and recreation services,
- hospitals and medical facilities,
- hotels and lodging places, and
- eating and drinking establishments.

A key assumption is that commercial operations would not be affected until water shortages were at least 50 percent of total municipal demand. In other words, we assume that residential water consumers would reduce water use including all non-essential uses before businesses were affected.

An example will illustrate the breakdown of municipal water needs and the overall approach to estimating impacts of municipal needs. Assume City A experiences an unexpected shortage of 50 acre-feet per year when their demands are 200 acre-feet per year. Thus, shortages are only 25 percent of total municipal use and residents of City A could eliminate needs by restricting landscape irrigation. City B, on the other hand, has a deficit of 150 acre-feet in 2020 and a projected demand of 200 acre-feet. Thus, total shortages are 75 percent of total demand. Emergency outdoor and some indoor conservation measures could eliminate 50 acre-feet of projected needs, yet 50 acre-feet would still remain. To eliminate” the remaining 50 acre-feet water intensive commercial businesses would have to curtail operations or shut down completely.

Three other areas were considered when analyzing municipal water shortages: 1) lost revenues to water utilities, 2) losses to the horticultural and landscaping industries stemming for reduction in water available for landscape irrigation, and 3) lost revenues and related economic impacts associated with reduced water related recreation.

Water Utility Revenues

Estimating lost water utility revenues was straightforward. We relied on annual data from the “*Water and Wastewater Rate Survey*” published annually by the Texas Municipal League to calculate an average value per acre-foot for water and sewer. For water revenues, average retail water and sewer rates multiplied by total water needs served as a proxy. For lost wastewater, total unmet needs were adjusted for return flow factor of 0.60 and multiplied by average sewer rates for the region. Needs reported as “county-other” were excluded under the presumption that these consist primarily of self-supplied water uses. In addition, 15 percent of water demand and needs are considered non-billed or “unaccountable” water that comprises things such as leakages and water for municipal government functions (e.g., fire departments). Lost tax receipts are based on current rates for the “miscellaneous gross receipts tax,” which the state collects from utilities located in most incorporated cities or towns in Texas. We do not include lost water utility revenues when aggregating impacts of municipal water shortages to regional and state levels to prevent double counting.

Horticultural and Landscaping Industry

The horticultural and landscaping industry, also referred to as the “green Industry,” consists of businesses that produce, distribute and provide services associated with ornamental plants, landscape and garden supplies and equipment. Horticultural industries often face big losses during drought. For example, the recent drought in the Southeast affecting the Carolinas and Georgia horticultural and landscaping businesses had a harsh year. Plant sales were down, plant mortality increased, and watering costs increased. Many businesses were forced to close locations, lay off employees, and even file for bankruptcy. University of Georgia economists put statewide losses for the industry at around \$3.2 billion during the 3-year drought that ended in 2008.¹⁷ Municipal restrictions on outdoor watering play a significant role. During drought, water restrictions coupled with persistent heat has a psychological effect on homeowners that reduces demands for landscaping products and services. Simply put, people were afraid to spend any money on new plants and landscaping.

In Texas, there do not appear to be readily available studies that analyze the economic effects of water shortages on the industry. However, authors of this report believe negative impacts do and would result in restricting landscape irrigation to municipal water consumers. The difficulty in measuring them is two-fold. First, as noted above, data and research for these types of impacts that focus on Texas are limited; and second, economic data provided by IMPLAN do not disaggregate different sectors of the green industry to a level that would allow for meaningful and defensible analysis.¹⁸

Recreational Impacts

Recreational businesses often suffer when water levels and flows in rivers, springs and reservoirs fall significantly during drought. During droughts, many boat docks and lake beaches are forced to close, leading to big losses for lakeside business owners and local communities. Communities adjacent to popular river and stream destinations such as Comal Springs and the Guadalupe River also see their business plummet when springs and rivers dry up. Although there are many examples of businesses that have suffered due to drought, dollar figures for drought-related losses to the recreation and tourism industry are not readily available, and very difficult to measure without extensive local surveys. Thus, while they are important, economic impacts are not measured in this study.

Table 7 summarizes impacts of municipal water shortages at differing levels of magnitude, and shows the ranges of economic costs or losses per acre-foot of shortage for each level.

¹⁷ Williams, D. “Georgia landscapers eye rebound from Southeast drought.” Atlanta Business Chronicle, Friday, June 19, 2009

¹⁸ Economic impact analyses prepared by the TWDB for 2006 regional water plans did include estimates for the horticultural industry. However, year 2000 and prior IMPLAN data were disaggregated to a finer level. In the current dataset (2006), the sector previously listed as “Landscaping and Horticultural Services” (IMPLAN Sector 27) is aggregated into “Services to Buildings and Dwellings” (IMPLAN Sector 458).

Table 7: Impacts of Municipal Water Shortages at Different Magnitudes of Shortages		
Water shortages as percent of total municipal demands	Impacts	Economic costs per acre-foot*
0-30%	<ul style="list-style-type: none"> ✓ Lost water utility revenues ✓ Restricted landscape irrigation and non-essential water uses 	\$730 - \$2,040
30-50%	<ul style="list-style-type: none"> ✓ Lost water utility revenues ✓ Elimination of landscape irrigation and non-essential water uses ✓ Rationing of indoor use 	\$2,040 - \$10,970
>50%	<ul style="list-style-type: none"> ✓ Lost water utility revenues ✓ Elimination of landscape irrigation and non-essential water uses ✓ Rationing of indoor use ✓ Restriction or elimination of commercial water use ✓ Importing water by tanker truck 	\$10,970 - varies
*Figures are rounded		

1.1.4 Industrial Water User Groups

Manufacturing

Impacts to manufacturing were estimated by distributing water shortages among industrial sectors at the county level. For example, if a planning group estimates that during a drought of record water supplies in County A would only meet 50 percent of total annual demands for manufactures in the county, we reduced output for each sector by 50 percent. Since projected manufacturing demands are based on TWDB Water Uses Survey data for each county, we only include IMPLAN sectors represented in the TWDB survey database. Some sectors in IMPLAN databases are not part of the TWDB database given that they use relatively small amounts of water - primarily for on-site sanitation and potable purposes. To maintain consistency between IMPLAN and TWDB databases, Standard Industrial Classification (SIC) codes both databases were cross referenced in county with shortages. Non-matches were excluded when calculating direct impacts.

Mining

The process of mining is very similar to that of manufacturing. We assume that within a given county, shortages would apply equally to relevant mining sectors, and IMPLAN sectors are cross referenced with TWDB data to ensure consistency.

In Texas, oil and gas extraction and sand and gravel (aggregates) operations are the primary mining industries that rely on large volumes of water. For sand and gravel, estimated output reductions are straightforward; however, oil and gas is more complicated for a number of reasons. IMPLAN does not necessarily report the physical extraction of minerals by geographic local, but rather the sales revenues reported by a particular corporation.

For example, at the state level revenues for IMPLAN sector 19 (oil and gas extraction) and sector 27 (drilling oil and gas wells) totals \$257 billion. Of this, nearly \$85 billion is attributed to Harris County. However, only a very small fraction (less than one percent) of actual production takes place in the county. To measure actual potential losses in well head capacity due to water shortages, we relied on county level production data from the Texas Railroad Commission (TRC) and average well-head market prices for crude and gas to estimate lost revenues in a given county. After which, we used to IMPLAN ratios to estimate resultant losses in income and employment.

Other considerations with respect to mining include:

- 1) Petroleum and gas extraction industry only uses water in significant amounts for secondary recovery. Known in the industry as enhanced or water flood extraction, secondary recovery involves pumping water down injection wells to increase underground pressure thereby pushing oil or gas into other wells. IMPLAN output numbers do not distinguish between secondary and non-secondary recovery. To account for the discrepancy, county-level TRC data that show the proportion of barrels produced using secondary methods were used to adjust IMPLAN data to reflect only the portion of sales attributed to secondary recovery.
- 2) A substantial portion of output from mining operations goes directly to businesses that are classified as manufacturing in our schema. Thus, multipliers measuring backward linkages for a given manufacturer might include impacts to a supplying mining operation. Care was taken not to double count in such situations if both a mining operation and a manufacturer were reported as having water shortages.

Steam-electric

At minimum without adequate cooling water, power plants cannot safely operate. As water availability falls below projected demands, water levels in lakes and rivers that provide cooling water would also decline. Low water levels could affect raw water intakes and outfalls at electrical generating units in several ways. For one, power plants are regulated by thermal emission guidelines that specify the maximum amount of heat that can go back into a river or lake via discharged cooling water. Low water levels could result in permit compliance issues due to reduced dilution and dispersion of heat and subsequent impacts on aquatic biota near outfalls.¹⁹ However, the primary concern would be a loss of head (i.e., pressure) over intake structures that would decrease flows through intake tunnels. This would affect safety related pumps, increase operating costs and/or result in sustained shut-downs. Assuming plants did shutdown, they would not be able to generate electricity.

¹⁹ Section 316 (b) of the Clean Water Act requires that thermal wastewater discharges do not harm fish and other wildlife.

Among all water use categories steam-electric is unique and cautions are needed when applying methods used in this study. Measured changes to an economy using input-output models stem directly from changes in sales revenues. In the case of water shortages, one assumes that businesses will suffer lost output if process water is in short supply. For power generation facilities this is true as well. However, the electric services sector in IMPLAN represents a corporate entity that may own and operate several electrical generating units in a given region. If one unit became inoperable due to water shortages, plants in other areas or generation facilities that do not rely heavily on water such as gas powered turbines might be able to compensate for lost generating capacity. Utilities could also offset lost production via purchases on the spot market.²⁰ Thus, depending upon the severity of the shortages and conditions at a given electrical generating unit, energy supplies for local and regional communities could be maintained. But in general, without enough cooling water, utilities would have to throttle back plant operations, forcing them to buy or generate more costly power to meet customer demands.

Measuring impacts end users of electricity is not part of this study as it would require extensive local and regional level analysis of energy production and demand. To maintain consistency with other water user groups, impacts of steam-electric water shortages are measured in terms of lost revenues (and hence income) and jobs associated with shutting down electrical generating units.

1.2 Social Impacts of Water Shortages

As the name implies, the effects of water shortages can be social or economic. Distinctions between the two are both semantic and analytical in nature – more so analytic in the sense that social impacts are harder to quantify. Nevertheless, social effects associated with drought and water shortages are closely tied to economic impacts. For example, they might include:

- demographic effects such as changes in population,
- disruptions in institutional settings including activity in schools and government,
- conflicts between water users such as farmers and urban consumers,
- health-related low-flow problems (e.g., cross-connection contamination, diminished sewage flows, increased pollutant concentrations),
- mental and physical stress (e.g., anxiety, depression, domestic violence),
- public safety issues from forest and range fires and reduced fire fighting capability,
- increased disease caused by wildlife concentrations,
- loss of aesthetic and property values, and
- reduced recreational opportunities.²¹

²⁰ Today, most utilities participate in large interstate “power pools” and can buy or sell electricity “on the grid” from other utilities or power marketers. Thus, assuming power was available to buy, and assuming that no contractual or physical limitations were in place such as transmission constraints; utilities could offset lost power that resulted from waters shortages with purchases via the power grid.

²¹ Based on information from the website of the National Drought Mitigation Center at the University of Nebraska Lincoln. Available online at: <http://www.drought.unl.edu/risk/impacts.htm>. See also, Vanclay, F. “*Social Impact Assessment*.” in Petts, J. (ed) *International Handbook of Environmental Impact Assessment*. 1999.

Social impacts measured in this study focus strictly on demographic effects including changes in population and school enrollment. Methods are based on demographic projection models developed by the Texas State Data Center and used by the TWDB for state and regional water planning. Basically, the social impact model uses results from the economic component of the study and assesses how changes in labor demand would affect migration patterns in a region. Declines in labor demand as measured using adjusted IMPLAN data are assumed to affect net economic migration in a given regional water planning area. Employment losses are adjusted to reflect the notion that some people would not relocate but would seek employment in the region and/or public assistance and wait for conditions to improve. Changes in school enrollment are simply the proportion of lost population between the ages of 5 and 17.

2. Results

Section 2 presents the results of the analysis at the regional level. Included are baseline economic data for each water use category, and estimated economics impacts of water shortages for water user groups with reported deficits. According to the 2011 *Rio Grande Regional Water Plan*, during severe drought irrigation- water user groups would experience water shortages in the absence of new water management strategies.

2.1 Overview of Regional Economy

On an annual basis, the Rio Grande regional economy generates roughly \$29 billion in gross state product for Texas (\$26 billion in income and \$2 billion worth of business taxes) and supports an estimated 567,277 jobs (Table 8). Generating about \$3.6 billion worth of income per year, agriculture, manufacturing, and mining are the primary base economic sectors in the region.²² Municipal sectors also generate substantial amounts of income and are major employers. However, while municipal sectors are the largest employer and source of wealth, many businesses that make up the municipal category such as restaurants and retail stores are non-basic industries meaning they exist to provide services to people who work would in base industries such as manufacturing, agriculture and mining. In other words, without base industries such agriculture, many municipal jobs in the region would not exist.

²² Base industries are those that supply markets outside of the region. These industries are crucial to the local economy and are called the economic base of a region. Appendix A shows how IMPLAN's 529 sectors were allocated to water use category, and shows economic data for each sector.

Table 8: The Rio Grande Regional Economy by Water User Group (\$millions)*						
Water Use Category	Total sales	Intermediate sales	Final sales	Jobs	Income	Business taxes
Irrigation	\$587.19	\$66.29	\$472.13	9,576	\$368.38	\$8.80
Livestock	\$337.00	\$162.43	\$174.57	3,253	\$28.32	\$4.20
Manufacturing	\$7,516.54	\$804.21	\$6,712.33	51,443	\$2,051.56	\$43.87
Mining	\$1,489.38	\$641.26	\$848.12	4,822	\$1,034.67	\$71.02
Steam-electric	\$295.72	\$83.19	\$212.53	790	\$205.34	\$35.05
Municipal	\$36,755.66	\$8,169.71	\$28,585.95	497,393	\$22,215.26	\$1,788.13
Regional total	\$46,981.49	\$9,927.09	\$37,005.63	567,277	\$25,903.53	\$1,951.07

^a Appendix 1 displays data for individual IMPLAN sectors that make up each water use category. Based on data from the Texas Water Development Board, and year 2006 data from the Minnesota IMPLAN Group, Inc.

2.2 Impacts of Agricultural Water Shortages

According to the 2011 *Rio Grande Regional Water Plan*, during severe drought the counties of Cameron, Hidalgo, Maverick, Starr, Webb, Willacy, and Zapata would experience shortages of irrigation water. Shortages range from 28 to 45 percent of annual irrigation demands, and farmers would be short nearly 407,500 acre-feet in 2010 and 258,375 acre-feet in 2060. Shortages of these magnitudes would reduce gross state product (income plus state and local business taxes) by an estimated \$126 million per year in 2010 and \$50 million in 2060.

Table 9: Economic Impacts of Water Shortages for Irrigation Water User Groups (\$millions)			
Decade	Lost income from reduced crop production ^a	Lost state and local tax revenues from reduced crop production	Lost jobs from reduced crop production
2010	\$123.82	\$2.91	1,235
2020	\$62.69	\$1.59	785
2030	\$44.56	\$1.16	613
2040	\$45.79	\$1.19	627
2050	\$47.02	\$1.22	641
2060	\$48.16	\$1.25	655

^aChanges to income and business taxes are collectively equivalent to a decrease in gross state product, which is analogous to gross domestic product measured at the state rather than national level. Appendix 2 shows results by water user group.

2.3 Impacts of Municipal Water Shortages

Water shortages are projected to occur in a significant number of communities in the region. Deficits range anywhere from 5 to 10 percent of total annual water demands. At the regional level, the estimated economic value of domestic water shortages totals \$176 million in 2010 and \$3,108 million in 2060 (Table 10). Due to curtailment of commercial business activity operation, municipal shortages would reduce gross state product (income plus taxes) by an estimated \$18 million in 2020 and \$2,460 million in 2060.

Table 10: Economic Impacts of Water Shortages for Municipal Water User Groups (\$millions)

Decade	Monetary value of domestic water shortages	Lost income from reduced commercial business activity*	Lost state and local taxes from reduced commercial business activity	Lost jobs from reduced commercial business activity	Lost water utility revenues
2010	\$176.41	\$15.43	\$2.23	510	\$38.93
2020	\$360.33	\$19.19	\$2.80	667	\$103.99
2030	\$848.77	\$36.04	\$4.82	1,135	\$188.77
2040	\$1,452.62	\$437.72	\$49.32	11,137	\$289.15
2050	\$2,277.47	\$988.84	\$109.90	24,585	\$412.11
2060	\$3,195.41	\$2,213.85	\$248.58	53,679	\$543.69

*Changes to Income and business taxes are collectively equivalent to a decrease in gross state product, which is analogous to gross domestic product measured at the state rather than national level. Appendix 2 shows results by water user group.

2.4 Impacts of Manufacturing Water Shortages

Manufacturing water shortages in the region are projected to occur in Cameron and Hidalgo counties. In 2010, the Rio Grande planning group estimates that these manufacturers would be short about 1,900 acre-feet; and by 2060, this figure increases to nearly 4,450 acre-feet. Shortages of these magnitudes would reduce gross state product (income plus taxes) by an estimated \$206 million in 2010 and \$453 million in 2060 (Table 11).

Table 11: Economic Impacts of Water Shortages for Manufacturing Water User Groups (\$millions)

Decade	Lost income due to reduced manufacturing output	Lost state and local business tax revenues due to reduced manufacturing output	Lost jobs due to reduced manufacturing output
2010	\$184.26	\$22.14	3,336
2020	\$226.44	\$27.20	4,100
2030	\$264.64	\$31.79	4,791
2040	\$302.44	\$36.33	5,476
2050	\$346.05	\$41.46	6,265
2060	\$404.80	\$48.37	7,329

*Changes to Income and business taxes are collectively equivalent to a decrease in gross state product, which is analogous to gross domestic product measured at the state rather than national level. Appendix 2 shows results by water user group.

2.5 Impacts of Steam-electric Water Shortages

Water shortages for electrical generating units are projected to occur in Cameron, Hidalgo and Webb counties, and would result in estimated losses of gross state product totaling \$19 million dollars in 2020, and \$306 million 2060 (Table 12).

Table 12: Economic Impacts of Water Shortages for Steam-electric Water User Groups (\$millions)

Decade	Lost income due to reduced electrical generation	Lost state and local business tax revenues due to reduced electrical generation	Lost jobs due to reduced electrical generation
2010	\$0.00	\$0.00	0
2020	\$16.70	\$2.40	57
2030	\$36.89	\$5.30	125
2040	\$122.99	\$17.65	418
2050	\$186.31	\$26.74	633
2060	\$267.93	\$38.46	911

*Changes to Income and business taxes are collectively equivalent to a decrease in gross state product, which is analogous to gross domestic product measured at the state rather than national level. Appendix 2 shows results by water user group.

2.6 Social Impacts of Water Shortages

As discussed previously, estimated social impacts focus on changes in population and school enrollment in the region. In 2010, estimated population losses total 6,112 with corresponding reductions in school enrollment of 1,724 students (Table 13). In 2060, population in the region would decline by 75,252 and school enrollment would fall by 21,349.

Table 13: Social Impacts of Water Shortages (2010-2060)		
Year	Population Losses	Declines in School Enrollment
2010	6,112	1,724
2020	6,756	1,917
2030	8,027	2,277
2040	21,269	6,034
2050	38,597	10,950
2060	75,252	21,349

2.7 Distribution of Impacts by Major River Basin

Administrative rules require that impacts are presented by both planning region and major river basin. To meet rule requirements, impacts were allocated among basins based on the distribution of water shortages in relevant basins. For example, if 50 percent of water shortages in River Basin A and 50 percent occur in River Basin B, then impacts were split equally among the two basins. Table 14 displays the results.

Table 14: Distribution of Impacts by Major River Basin (2010-2060)						
River Basin	2010	2020	2030	2040	2050	2060
Nueces	1%	1%	1%	1%	1%	1%
Nueces-Rio Grande	80%	76%	71%	70%	70%	70%
Rio Grande	19%	23%	28%	29%	29%	29%

Appendix 1: Economic Data for Individual IMPLAN Sectors

Economic Data for Agricultural Water User Groups (\$millions)								
Water Use Category	IMPLAN Sector	IMPLAN Code	Total Sales	Intermediate Sales	Final Sales	Jobs	Income	Business Taxes
Irrigation	Oilseed Farming	1	\$0.79	\$0.20	\$0.59	17	\$0.38	\$0.02
Irrigation	Grain Farming	2	\$42.70	\$11.19	\$31.33	1,265	\$19.56	\$0.77
Irrigation	Vegetable and Melon Farming	3	\$328.47	\$9.66	\$318.81	3,755	\$241.23	\$3.09
Irrigation	Tree Nut Farming	4	\$22.56	\$0.00	\$22.56	295	\$15.24	\$0.55
Irrigation	Fruit Farming	6	\$85.84	\$12.52	\$73.32	1,346	\$49.11	\$1.86
Irrigation	Cotton Farming	8	\$23.86	\$1.53	\$22.33	283	\$8.79	\$0.22
Irrigation	Sugarcane and Sugar Beet Farming	9	\$48.83	\$0.98	\$47.85	2,339	\$17.29	\$1.63
Irrigation	All "Other" Crop Farming	10	\$34.14	\$31.19	\$3.19	276	\$16.78	\$0.66
	Total irrigation	NA	\$587.19	\$66.29	\$472.13	9,576	\$368.38	\$8.80
Livestock	Animal- except poultry- slaughtering	67	\$153.41	\$41.02	\$112.39	412	\$13.09	\$0.73
Livestock	Cattle ranching and farming	11	\$153.34	\$106.32	\$47.01	2,472	\$12.11	\$3.22
Livestock	Meat processed from carcasses	68	\$18.98	\$5.60	\$13.38	44	\$1.76	\$0.09
Livestock	Animal production- except cattle and poultry	13	\$10.18	\$8.63	\$1.55	320	\$0.99	\$0.16
Livestock	Poultry and egg production	12	\$1.09	\$0.85	\$0.24	5	\$0.37	\$0.00
Livestock	Animal- except poultry- slaughtering	67	\$153.41	\$41.02	\$112.39	412	\$13.09	\$0.73
	Total livestock	NA	\$337.00	\$162.43	\$174.57	3,253	\$28.32	\$4.20
	Total agriculture		\$924.19	\$229.69	\$694.55	12,829	\$396.70	\$13.00
Based on year 2006 data from the Minnesota IMPLAN Group, Inc.								

Economic Data for Mining and Steam-electric Water User Groups (\$millions)								
Water Use Category	IMPLAN Sector	IMPLAN Code	Total Sales	Intermediate Sales	Final Sales	Jobs	Income	Business Taxes
Mining	Support activities for oil and gas operations	28	\$701.94	\$97.50	\$604.44	3,431	\$636.63	\$28.62
Mining	Oil and gas extraction	19	\$580.52	\$539.12	\$41.40	907	\$333.91	\$35.21
Mining	Drilling oil and gas wells	27	\$175.11	\$0.87	\$174.23	295	\$47.62	\$6.28
Mining	Other nonmetallic mineral mining	26	\$15.37	\$1.54	\$13.83	60	\$7.62	\$0.47
Mining	Sand- gravel- clay- and refractory mining	25	\$14.65	\$1.55	\$13.10	115	\$8.44	\$0.43
Mining	Gold- silver- and other metal ore mining	23	\$1.13	\$0.63	\$0.50	10	\$0.10	\$0.01
Mining	Stone mining and quarrying	24	\$0.56	\$0.06	\$0.50	3	\$0.31	\$0.00
Mining	Support activities for other mining	29	\$0.12	\$0.00	\$0.11	1	\$0.04	\$0.01
	Total mining	NA	\$1,489.38	\$641.26	\$848.12	4,822	\$1,034.67	\$71.02
Steam-electric	Power generation and supply	30	\$295.72	\$83.19	\$212.53	790	\$205.34	\$35.05
Based on year 2006 data from the Minnesota IMPLAN Group, Inc.								

Economic Data for Manufacturing Water User Groups (\$millions)

Water Use Category	IMPLAN Sector	IMPLAN	Intermediate		Jobs	Income	Business Taxes	
		Code	Total Sales	Sales				Final Sales
Manufacturing	New residential 1-unit structures- all	33	\$1,041.91	\$0.00	\$1,041.91	7,615	\$298.50	\$4.70
Manufacturing	Commercial and institutional buildings	38	\$554.41	\$0.00	\$554.41	6,638	\$255.32	\$3.16
Manufacturing	Flour milling	48	\$373.27	\$23.80	\$349.47	489	\$40.43	\$2.27
Manufacturing	Motor vehicle parts manufacturing	350	\$368.28	\$29.61	\$338.67	1,061	\$73.64	\$1.13
Manufacturing	Other oilseed processing	53	\$345.06	\$11.24	\$333.82	165	\$13.88	\$1.86
Manufacturing	Construction machinery manufacturing	259	\$281.29	\$38.39	\$242.90	452	\$23.42	\$0.71
Manufacturing	Ship building and repairing	357	\$272.69	\$1.58	\$271.11	1,691	\$82.69	\$0.93
Manufacturing	Other new construction	41	\$239.53	\$0.00	\$239.53	3,045	\$118.49	\$0.93
Manufacturing	Agriculture and forestry support activities	18	\$235.57	\$133.91	\$101.66	9,428	\$156.33	\$1.76
Manufacturing	Ready-mix concrete manufacturing	192	\$176.82	\$0.86	\$175.96	748	\$43.38	\$1.08
Manufacturing	Paperboard container manufacturing	126	\$165.55	\$1.75	\$163.80	561	\$35.93	\$1.39
Manufacturing	Fruit and vegetable canning and drying	61	\$164.09	\$6.08	\$158.01	408	\$22.71	\$0.70
Manufacturing	Soft drink and ice manufacturing	85	\$157.13	\$8.78	\$148.36	254	\$20.85	\$0.92
Manufacturing	New residential additions and alterations-all	35	\$145.30	\$0.00	\$145.30	907	\$47.26	\$0.67
Manufacturing	Seafood product preparation and packaging	71	\$142.04	\$70.24	\$71.80	546	\$10.63	\$0.28
Manufacturing	Coated and uncoated paper bag manufacturing	130	\$124.31	\$3.51	\$120.80	473	\$22.71	\$0.79
Manufacturing	Highway- street- bridge- and tunnel construct	39	\$118.74	\$0.00	\$118.74	1,286	\$54.68	\$0.70
Manufacturing	New multifamily housing structures- all	34	\$108.80	\$0.00	\$108.80	1,106	\$46.20	\$0.27
Manufacturing	Frozen food manufacturing	60	\$102.23	\$3.21	\$99.03	419	\$11.90	\$0.32
Manufacturing	Aircraft manufacturing	351	\$98.51	\$5.01	\$93.50	202	\$14.50	\$0.30
Manufacturing	Motor vehicle body manufacturing	346	\$98.19	\$5.70	\$92.49	357	\$15.34	\$0.34
Manufacturing	Motor and generator manufacturing	334	\$89.93	\$8.54	\$81.38	362	\$25.26	\$0.55
Manufacturing	Water- sewer- and pipeline construction	40	\$88.39	\$0.00	\$88.39	841	\$35.09	\$0.51
Manufacturing	Hunting and trapping	17	\$77.24	\$6.32	\$70.92	439	\$23.72	\$4.44
Manufacturing	Forest nurseries- forest products- and timber	15	\$76.26	\$1.18	\$75.09	132	\$10.95	\$1.75
Manufacturing	Metal valve manufacturing	248	\$70.57	\$7.64	\$62.92	275	\$29.89	\$0.39
Manufacturing	All other manufacturing		\$1,729.89	\$434.61	\$1,295.28	10,863	\$502.82	\$10.82
Manufacturing	Total manufacturing		\$7,516.54	\$804.21	\$6,712.33	51,443	\$2,051.56	\$43.87

Based on year 2006 data from the Minnesota IMPLAN Group, Inc.

Economic Data for Municipal Water User Groups (\$millions)

Water Use Category	IMPLAN Sector	IMPLAN	Intermediate		Jobs	Income	Business Taxes	
		Code	Total Sales	Sales				Final Sales
Municipal	State & Local Education	503	\$2,872.91	\$0.00	\$2,872.90	74,700	\$2,872.90	\$0.00
Municipal	Owner-occupied dwellings	509	\$2,647.04	\$0.00	\$2,647.04	0	\$2,050.58	\$313.00
Municipal	Wholesale trade	390	\$1,921.04	\$919.72	\$1,001.32	16,298	\$1,010.52	\$285.00
Municipal	Hospitals	467	\$1,740.08	\$0.00	\$1,740.08	13,940	\$975.26	\$12.46
Municipal	Monetary authorities and depository credit in	430	\$1,733.72	\$571.01	\$1,162.71	8,871	\$1,217.44	\$22.18
Municipal	Food services and drinking places	481	\$1,558.30	\$198.99	\$1,359.30	34,123	\$612.65	\$71.61
Municipal	Truck transportation	394	\$1,520.81	\$823.48	\$697.34	13,157	\$626.91	\$14.24
Municipal	Offices of physicians- dentists- and other he	465	\$1,376.77	\$0.00	\$1,376.77	13,818	\$960.83	\$8.40
Municipal	State & Local Non-Education	504	\$1,272.59	\$0.00	\$1,272.59	23,176	\$1,272.59	\$0.00
Municipal	Federal Non-Military	506	\$1,254.27	\$0.00	\$1,254.26	7,677	\$1,254.27	\$0.00
Municipal	Home health care services	464	\$1,240.24	\$0.01	\$1,240.24	41,747	\$701.40	\$4.12
Municipal	Real estate	431	\$1,070.39	\$423.72	\$646.67	7,015	\$619.45	\$131.74
Municipal	Motor vehicle and parts dealers	401	\$929.81	\$101.11	\$828.70	9,435	\$476.11	\$135.01
Municipal	Telecommunications	422	\$875.21	\$300.62	\$574.59	2,632	\$350.89	\$58.66
Municipal	General merchandise stores	410	\$803.47	\$84.68	\$718.79	15,679	\$353.06	\$112.32
Municipal	Other State and local government enterprises	499	\$759.62	\$247.35	\$512.26	3,759	\$265.66	\$0.09
Municipal	Scenic and sightseeing transportation and sup	397	\$657.16	\$246.54	\$410.62	9,272	\$446.86	\$75.11
Municipal	Food and beverage stores	405	\$653.61	\$87.39	\$566.22	12,000	\$328.89	\$72.05
Municipal	Legal services	437	\$516.88	\$328.04	\$188.84	5,486	\$309.72	\$9.81
Municipal	Other ambulatory health care services	466	\$479.93	\$31.21	\$448.71	3,976	\$208.81	\$3.09
Municipal	Clothing and clothing accessories stores	408	\$450.59	\$56.41	\$394.17	8,756	\$230.89	\$65.51
Municipal	Social assistance- except child day care services	470	\$424.55	\$0.08	\$424.47	16,832	\$179.71	\$1.24
Municipal	Building material and garden supply stores	404	\$375.36	\$58.21	\$317.14	4,864	\$172.99	\$52.61
Municipal	Business support services	455	\$312.99	\$146.48	\$166.51	6,877	\$151.73	\$5.73
Municipal	Architectural and engineering services	439	\$305.74	\$192.73	\$113.01	2,975	\$145.46	\$1.22
Municipal	Civic- social- professional and similar organ	493	\$305.42	\$107.31	\$198.11	8,549	\$157.56	\$0.99
Municipal	All other municipal	NA	\$8,697.19	\$3,244.61	\$5,452.57	131,779	\$4,262.14	\$331.94
Municipal	Total		\$36,755.66	\$8,169.71	\$28,585.95	497,393	\$22,215.26	\$1,788.13

Based on year 2006 data from the Minnesota IMPLAN Group, Inc.

Appendix 2: Impacts by Water User Group

Irrigation (\$millions)						
	2010	2020	2030	2040	2050	2060
Cameron						
Reduced income from lost crop production	\$19.10	\$16.64	\$13.74	\$14.03	\$14.32	\$14.58
Reduced business taxes from lost crop production	\$0.59	\$0.51	\$0.42	\$0.43	\$0.44	\$0.45
Reduced jobs from lost crop production	363	317	261	267	273	278
Hidalgo						
Reduced income from lost crop production	\$79.47	\$28.76	\$14.62	\$15.30	\$15.99	\$16.62
Reduced business taxes from lost crop production	\$1.75	\$0.63	\$0.32	\$0.34	\$0.35	\$0.37
Reduced jobs from lost crop production	607	220	112	117	122	127
Maverick						
Reduced income from lost crop production	\$14.17	\$6.57	\$5.95	\$6.05	\$6.14	\$6.23
Reduced business taxes from lost crop production	\$0.32	\$0.19	\$0.17	\$0.18	\$0.18	\$0.18
Reduced jobs from lost crop production	104	85	77	79	80	81
Starr						
Reduced income from lost crop production	\$1.78	\$1.59	\$1.41	\$1.44	\$1.47	\$1.50
Reduced business taxes from lost crop production	\$0.03	\$0.02	\$0.02	\$0.02	\$0.02	\$0.02
Reduced jobs from lost crop production	12	11	10	10	10	10
Webb						
Reduced income from lost crop production	\$1.97	\$1.72	\$1.49	\$1.52	\$1.55	\$1.57
Reduced business taxes from lost crop production	\$0.03	\$0.03	\$0.02	\$0.03	\$0.03	\$0.03
Reduced jobs from lost crop production	13	11	10	10	10	10
Willacy						
Reduced income from lost crop production	\$5.37	\$5.67	\$5.84	\$5.91	\$5.98	\$6.05
Reduced business taxes from lost crop production	\$0.16	\$0.17	\$0.17	\$0.18	\$0.18	\$0.18
Reduced jobs from lost crop production	123	130	134	135	137	138
Zapata						
Reduced income from lost crop production	\$1.97	\$1.74	\$1.52	\$1.55	\$1.58	\$1.60
Reduced business taxes from lost crop production	\$0.03	\$0.03	\$0.02	\$0.02	\$0.02	\$0.02
Reduced jobs from lost crop production	13	11	10	10	10	10

Manufacturing (\$millions)						
	2010	2020	2030	2040	2050	2060
Cameron County						
Reduced income from lost manufacturing	\$184.26	\$226.44	\$264.64	\$302.44	\$335.19	\$379.51
Reduced business taxes from lost manufacturing	\$22.14	\$27.20	\$31.79	\$36.33	\$40.27	\$45.59
Reduced jobs from lost crop livestock manufacturing	3,336	4,100	4,791	5,476	6,069	6,871
Hidalgo County						
Reduced income from lost manufacturing	\$0.00	\$0.00	\$0.00	\$0.00	\$10.85	\$25.28
Reduced business taxes from lost manufacturing	\$0.00	\$0.00	\$0.00	\$0.00	\$1.19	\$2.78
Reduced jobs from lost crop livestock manufacturing	0	0	0	0	196	458

Steam-electric (\$millions)						
	2010	2020	2030	2040	2050	2060
Cameron County						
Reduced income from lost electrical generation	\$0.00	\$0.00	\$0.00	\$0.00	\$0.89	\$6.29
Reduced business taxes from lost electrical generation	\$0.00	\$0.00	\$0.00	\$0.00	\$0.13	\$0.90
Reduced jobs from lost electrical generation	0	0	0	0	3	21
Hidalgo County						
Reduced income from lost electrical generation	\$0.00	\$16.70	\$36.89	\$122.99	\$182.97	\$256.11
Reduced business taxes from lost electrical generation	\$0.00	\$2.40	\$5.30	\$17.65	\$26.26	\$36.76
Reduced jobs from lost electrical generation	0	57	125	418	622	871
Webb County						
Reduced income from lost electrical generation	0	0	0	0	\$2.45	\$5.52
Reduced business taxes from lost electrical generation	0	0	0	0	\$0.35	\$0.79
Reduced jobs from lost electrical generation	0	0	0	0	8	19

Municipal (\$millions)						
	2010	2020	2030	2040	2050	2060
Alamo						
Monetary value of domestic water shortages	\$0.05	\$4.40	\$18.75	\$24.08	\$33.17	\$50.40
Lost income from reduced commercial business activity	\$0.00	\$0.00	\$0.00	\$5.86	\$9.87	\$27.98
Lost jobs due to reduced commercial business activity	0	0	0	185	311	882
Lost state and local taxes from reduced commercial business activity	\$0.00	\$0.00	\$0.00	\$0.83	\$1.41	\$3.99
Lost utility revenues	\$0.11	\$1.37	\$2.78	\$4.34	\$6.13	\$7.95
Alton						
Monetary value of domestic water shortages	\$0.00	\$0.00	\$17.22	\$33.49	\$51.71	\$64.37
Lost income from reduced commercial business activity	\$0.00	\$0.00	\$0.00	\$9.27	\$13.54	\$36.11
Lost jobs due to reduced commercial business activity	0	0	0	584	854	1,139
Lost state and local taxes from reduced commercial business activity	\$0.00	\$0.00	\$0.00	\$1.32	\$1.93	\$5.15
Lost utility revenues	\$0.00	\$0.00	\$4.84	\$6.77	\$8.88	\$11.09
Brownsville						
Monetary value of domestic water shortages	\$9.13	\$23.47	\$149.52	\$247.63	\$399.63	\$465.79
Lost income from reduced commercial business activity	\$0.00	\$0.00	\$0.00	\$0.00	\$261.86	\$345.50
Lost jobs due to reduced commercial business activity	0	0	0	0	5,826	7,687
Lost state and local taxes from reduced commercial business activity	\$0.00	\$0.00	\$0.00	\$0.00	\$27.87	\$36.77
Lost utility revenues	\$14.79	\$30.60	\$46.58	\$63.25	\$79.82	\$96.19
County-other (Hidalgo)						
Monetary value of domestic water shortages	\$0.00	\$3.04	\$32.68	\$73.03	\$135.24	\$242.12
County-other (Jim Hogg)						
Monetary value of domestic water shortages	\$0.66	\$0.72	\$0.86	\$0.89	\$0.87	\$0.79
County-other (Maverick)						
Monetary value of domestic water shortages	\$0.06	\$0.81	\$1.89	\$9.47	\$13.10	\$17.19
County-other (Starr)						
Monetary value of domestic water shortages	\$68.67	\$148.68	\$185.90	\$223.97	\$260.26	\$294.62
County-other (Webb)						
Monetary value of domestic water shortages	\$0.16	\$0.55	\$0.96	\$4.80	\$7.76	\$11.06

Municipal (cont.)						
	2010	2020	2030	2040	2050	2060
County-other (Webb)						
Monetary value of domestic water shortages	\$0.27	\$0.68	\$5.21	\$3.93	\$4.73	\$5.83
Donna						
Monetary value of domestic water shortages	\$0.00	\$0.00	\$0.00	\$0.00	\$0.00	\$0.09
Lost utility revenues	\$0.00	\$0.00	\$0.00	\$0.00	\$0.00	\$0.20
East Honda WSC						
Monetary value of domestic water shortages	\$0.00	\$0.00	\$0.00	\$0.00	\$0.25	\$1.29
Lost utility revenues	\$0.00	\$0.00	\$0.00	\$0.00	\$0.55	\$1.99
Edcouch						
Monetary value of domestic water shortages	\$0.19	\$1.09	\$1.80	\$4.02	\$5.09	\$5.28
Lost income from reduced commercial business activity	\$0.00	\$0.00	\$0.00	\$0.00	\$0.00	\$0.53
Lost jobs due to reduced commercial business activity	0	0	0	0	0	21
Lost state and local taxes from reduced commercial business activity	\$0.00	\$0.00	\$0.00	\$0.00	\$0.00	\$0.08
Lost utility revenues	\$0.23	\$0.34	\$0.46	\$0.60	\$0.76	\$0.93
Edinburgh						
Monetary value of domestic water shortages	\$0.00	\$0.00	\$0.00	\$1.85	\$7.43	\$45.34
Lost utility revenues	\$0.00	\$0.00	\$0.00	\$3.25	\$9.26	\$15.43
El Cenizo						
Monetary value of domestic water shortages	\$0.00	\$0.05	\$0.61	\$4.61	\$11.08	\$15.02
Lost income from reduced commercial business activity	\$0.00	\$0.00	\$0.00	\$0.00	\$2.93	\$4.64
Lost jobs due to reduced commercial business activity	0	0	0	0	92	146
Lost state and local taxes from reduced commercial business activity	\$0.00	\$0.00	\$0.00	\$0.00	\$0.42	\$0.66
Lost utility revenues	\$0.00	\$0.11	\$0.74	\$1.44	\$2.23	\$3.08
El Jardin						
Monetary value of domestic water shortages	\$0.36	\$1.19	\$6.76	\$11.38	\$20.00	\$24.21
Lost income from reduced commercial business activity	\$0.00	\$0.00	\$0.00	\$0.00	\$5.55	\$7.32
Lost jobs due to reduced commercial business activity	0	0	0	0	175	231
Lost state and local taxes from reduced commercial business activity	\$0.00	\$0.00	\$0.00	\$0.00	\$0.79	\$1.04
Lost utility revenues	\$0.61	\$1.45	\$2.32	\$3.20	\$4.07	\$4.94

Municipal (cont.)						
	2010	2020	2030	2040	2050	2060
Harlingen						
Monetary value of domestic water shortages	\$0.00	\$0.00	\$0.00	\$0.00	\$1.41	\$3.49
Lost utility revenues	\$0.00	\$0.00	\$0.00	\$0.00	\$2.48	\$5.47
Hidalgo						
Monetary value of domestic water shortages	\$0.00	\$0.01	\$0.24	\$1.15	\$7.24	\$15.58
Lost income from reduced commercial business activity	\$0.00	\$0.00	\$0.00	\$0.00	\$0.00	\$5.74
Lost jobs due to reduced commercial business activity	0	0	0	0	0	138
Lost state and local taxes from reduced commercial business activity	\$0.00	\$0.00	\$0.00	\$0.00	\$0.00	\$4.99
Lost utility revenues	\$0.00	\$0.03	\$0.43	\$1.28	\$2.26	\$3.26
Hidalgo County MUD#1						
Monetary value of domestic water shortages	\$34.98	\$58.71	\$87.21	\$123.26	\$157.30	\$107.53
Lost income from reduced commercial business activity	\$2.24	\$3.59	\$5.12	\$6.77	\$8.60	\$10.47
Lost jobs due to reduced commercial business activity	\$2.76	\$4.89	\$7.30	\$9.89	\$12.76	\$15.71
Lost state and local taxes from reduced commercial business activity	\$0.43	\$0.76	\$1.13	\$1.53	\$1.98	\$2.44
Lost utility revenues	111	196	293	398	513	632
Indian Lake						
Monetary value of domestic water shortages	\$0.25	\$0.38	\$0.28	\$0.46	\$0.66	\$1.18
Lost income from reduced commercial business activity	\$0.00	\$0.00	\$0.03	\$0.05	\$0.06	\$0.08
Lost jobs due to reduced commercial business activity	0	0	1	2	3	3
Lost state and local taxes from reduced commercial business activity	\$0.00	\$0.00	\$0.01	\$0.01	\$0.01	\$0.01
Lost utility revenues	\$0.04	\$0.05	\$0.07	\$0.09	\$0.11	\$0.13
La Grulla						
Monetary value of domestic water shortages	\$5.52	\$7.46	\$8.53	\$6.96	\$7.73	\$8.63
Lost income from reduced commercial business activity	\$0.00	\$0.00	\$0.00	\$1.03	\$1.27	\$1.60
Lost jobs due to reduced commercial business activity	0	0	0	18	23	27
Lost state and local taxes from reduced commercial business activity	\$0.00	\$0.00	\$0.00	\$0.53	\$0.64	\$0.77
Lost utility revenues	\$0.68	\$0.79	\$0.90	\$1.02	\$1.15	\$1.29

Municipal (cont.)						
	2010	2020	2030	2040	2050	2060
La Joya						
Monetary value of domestic water shortages	\$0.00	\$0.01	\$0.12	\$0.31	\$2.22	\$3.41
Lost utility revenues	\$0.00	\$0.01	\$0.17	\$0.34	\$0.53	\$0.75
Laguna Madre WD						
Monetary value of domestic water shortages	\$0.00	\$0.00	\$0.65	\$2.71	\$16.14	\$27.20
Lost utility revenues	\$0.00	\$0.00	\$1.02	\$3.01	\$5.03	\$6.95
Laredo						
Monetary value of domestic water shortages	\$4.76	\$26.01	\$198.41	\$320.89	\$498.32	\$752.76
Lost income from reduced commercial business activity	\$0.00	\$0.00	\$0.00	\$292.93	\$465.20	\$1,304.36
Lost jobs due to reduced commercial business activity	0	0	0	6,517	10,349	29,019
Lost state and local taxes from reduced commercial business activity	\$0.00	\$0.00	\$0.00	\$31.17	\$49.51	\$138.81
Lost utility revenues	\$9.52	\$33.91	\$61.81	\$92.91	\$126.62	\$163.22
Los Fresnos						
Monetary value of domestic water shortages	\$0.00	\$0.00	\$0.18	\$0.70	\$5.31	\$8.77
Lost utility revenues	\$0.00	\$0.00	\$0.29	\$0.77	\$1.27	\$1.75
McAllen						
Monetary value of domestic water shortages	\$0.00	\$2.56	\$10.89	\$24.05	\$126.60	\$207.37
Lost utility revenues	\$0.00	\$4.50	\$15.24	\$26.67	\$39.44	\$52.97
Military Highway WSC						
Monetary value of domestic water shortages	\$0.00	\$0.00	\$0.00	\$0.07	\$1.16	\$2.84
Lost utility revenues	\$0.00	\$0.00	\$0.00	\$0.16	\$1.71	\$3.32
Mission						
Monetary value of domestic water shortages	\$1.68	\$7.25	\$49.95	\$111.71	\$149.64	\$223.31
Lost income from reduced commercial business activity	\$0.00	\$0.00	\$0.00	\$66.64	\$104.34	\$285.95
Lost jobs due to reduced commercial business activity	0	0	0	1,482	2,321	6,362
Lost state and local taxes from reduced commercial business activity	\$0.00	\$0.00	\$0.00	\$7.09	\$11.10	\$30.43
Lost utility revenues	\$2.64	\$8.03	\$14.07	\$20.43	\$27.81	\$35.38

Municipal (cont.)						
	2010	2020	2030	2040	2050	2060
North Alamo WSC						
Monetary value of domestic water shortages	\$0.00	\$0.00	\$0.00	\$2.51	\$10.77	\$48.66
Lost utility revenues	\$0.00	\$0.00	\$0.00	\$4.85	\$14.78	\$24.88
Olmito WSC						
Monetary value of domestic water shortages	\$0.00	\$0.46	\$4.01	\$9.14	\$14.01	\$20.78
Lost income from reduced commercial business activity	\$0.00	\$0.00	\$0.00	\$0.99	\$1.59	\$2.16
Lost jobs due to reduced commercial business activity	0	0	0	40	64	87
Lost state and local taxes from reduced commercial business activity	\$0.00	\$0.00	\$0.00	\$0.15	\$0.25	\$0.33
Lost utility revenues	\$0.00	\$0.57	\$1.25	\$1.91	\$2.60	\$3.26
Palm Valley						
Monetary value of domestic water shortages	\$0.13	\$0.12	\$0.11	\$0.09	\$0.08	\$0.08
Lost utility revenues	\$0.15	\$0.14	\$0.12	\$0.11	\$0.10	\$0.10
Palm Valley Estates UD						
Monetary value of domestic water shortages	\$0.01	\$0.02	\$0.04	\$0.09	\$0.50	\$0.70
Lost utility revenues	\$0.01	\$0.03	\$0.06	\$0.09	\$0.12	\$0.15
Palmhurst						
Monetary value of domestic water shortages	\$0.00	\$0.00	\$0.00	\$0.30	\$1.19	\$2.65
Lost utility revenues	\$0.00	\$0.00	\$0.00	\$0.59	\$1.84	\$3.23
Palmview						
Monetary value of domestic water shortages	\$0.00	\$0.00	\$0.00	\$0.00	\$0.71	\$1.84
Lost utility revenues	\$0.00	\$0.00	\$0.00	\$0.00	\$0.89	\$1.79
Penitas						
Monetary value of domestic water shortages	\$0.00	\$0.00	\$0.00	\$0.00	\$0.01	\$0.02
Lost utility revenues	\$0.00	\$0.00	\$0.00	\$0.00	\$0.01	\$0.03

Municipal (cont.)						
	2010	2020	2030	2040	2050	2060
Pharr						
Monetary value of domestic water shortages	\$0.00	\$2.01	\$6.73	\$39.24	\$67.93	\$124.37
Lost income from reduced commercial business activity	\$0.00	\$0.00	\$0.00	\$0.00	\$0.00	\$34.40
Lost jobs due to reduced commercial business activity	0	0	0	0	0	1,085
Lost state and local taxes from reduced commercial business activity	\$0.00	\$0.00	\$0.00	\$0.00	\$0.00	\$4.90
Lost utility revenues	\$0.00	\$3.47	\$8.22	\$13.46	\$19.11	\$25.14
Port Isabella						
Monetary value of domestic water shortages	\$33.67	\$37.00	\$41.05	\$45.40	\$49.14	\$52.79
Lost income from reduced commercial business activity	\$12.67	\$14.30	\$15.97	\$17.60	\$19.35	\$21.06
Lost jobs due to reduced commercial business activity	400	451	503	555	610	664
Lost state and local taxes from reduced commercial business activity	\$1.81	\$2.04	\$2.28	\$2.51	\$2.76	\$3.00
Lost utility revenues	\$3.74	\$4.14	\$4.55	\$4.95	\$5.37	\$5.79
Primera						
Monetary value of domestic water shortages	\$1.10	\$2.12	\$4.71	\$6.01	\$12.83	\$15.97
Lost income from reduced commercial business activity	\$0.00	\$0.00	\$0.44	\$0.65	\$0.86	\$1.06
Lost jobs due to reduced commercial business activity	0	0	18	26	34	43
Lost state and local taxes from reduced commercial business activity	\$0.00	\$0.00	\$0.07	\$0.10	\$0.13	\$0.17
Lost utility revenues	\$0.38	\$0.60	\$0.82	\$1.06	\$1.30	\$1.54
Rio Bravo						
Monetary value of domestic water shortages	\$0.00	\$0.58	\$11.78	\$16.50	\$27.00	\$44.50
Lost income from reduced commercial business activity	\$0.00	\$0.00	\$0.00	\$1.13	\$2.01	\$5.84
Lost jobs due to reduced commercial business activity	0	0	0	46	81	235
Lost state and local taxes from reduced commercial business activity	\$0.00	\$0.00	\$0.00	\$0.18	\$0.31	\$0.91
Lost utility revenues	\$0.00	\$0.51	\$1.32	\$2.22	\$3.22	\$4.27
Rio Grande City						
Monetary value of domestic water shortages	\$0.55	\$1.09	\$1.73	\$2.21	\$9.77	\$12.91
Lost utility revenues	\$0.87	\$1.36	\$1.92	\$2.45	\$3.04	\$3.66

Municipal (cont.)						
	2010	2020	2030	2040	2050	2060
Rio WSC						
Monetary value of domestic water shortages	\$1.91	\$3.44	\$6.92	\$10.66	\$13.94	\$17.11
Lost income from reduced commercial business activity	\$0.00	\$0.00	\$0.51	\$1.46	\$1.93	\$2.38
Lost jobs due to reduced commercial business activity	0	0	21	59	78	96
Lost state and local taxes from reduced commercial business activity	\$0.00	\$0.00	\$0.08	\$0.23	\$0.30	\$0.37
Lost utility revenues	\$0.34	\$0.62	\$0.91	\$1.19	\$1.49	\$1.77
Roma City						
Monetary value of domestic water shortages	\$0.09	\$0.56	\$1.29	\$2.13	\$10.06	\$13.81
Lost utility revenues	\$0.21	\$0.97	\$1.77	\$2.60	\$3.45	\$4.31
San Benito						
Monetary value of domestic water shortages	\$0.00	\$0.00	\$0.00	\$0.00	\$0.19	\$0.85
Lost utility revenues	\$0.00	\$0.00	\$0.00	\$0.00	\$0.38	\$1.49
San Juan						
Monetary value of domestic water shortages	\$0.55	\$8.68	\$20.65	\$42.22	\$69.32	\$137.01
Lost income from reduced commercial business activity	\$0.00	\$0.00	\$0.00	\$12.41	\$38.15	\$51.83
Lost jobs due to reduced commercial business activity	0	0	0	391	1,203	1,634
Lost state and local taxes from reduced commercial business activity	\$0.00	\$0.00	\$0.00	\$1.77	\$5.44	\$7.39
Lost utility revenues	\$0.95	\$3.25	\$5.81	\$8.64	\$11.90	\$15.24
San Perlita						
Monetary value of domestic water shortages	\$0.00	\$0.00	\$0.00	\$0.00	\$0.01	\$0.01
Lost utility revenues	\$0.00	\$0.00	\$0.00	\$0.00	\$0.01	\$0.01
Sebastian						
Monetary value of domestic water shortages	\$0.00	\$0.00	\$0.04	\$0.10	\$0.13	\$0.17
Lost utility revenues	\$0.00	\$0.00	\$0.07	\$0.12	\$0.16	\$0.18
Sharyland WSC						
Monetary value of domestic water shortages	\$0.00	\$0.40	\$0.41	\$1.71	\$3.72	\$19.25
Lost utility revenues	\$0.00	\$0.77	\$0.79	\$2.64	\$4.55	\$6.60

Municipal (cont.)						
	2010	2020	2030	2040	2050	2060
South Padre Island						
Monetary value of domestic water shortages	\$8.23	\$16.74	\$12.58	\$18.82	\$30.52	\$36.03
Lost income from reduced commercial business activity	\$0.00	\$0.00	\$11.79	\$17.80	\$47.58	\$59.10
Lost jobs due to reduced commercial business activity	0	0	262	396	1,059	1,315
Lost state and local taxes from reduced commercial business activity	\$0.00	\$0.00	\$1.25	\$1.89	\$5.06	\$6.29
Lost utility revenues	\$1.35	\$2.48	\$3.66	\$4.83	\$6.01	\$7.13
Sullivan City						
Monetary value of domestic water shortages	\$0.00	\$0.00	\$0.00	\$0.00	\$0.27	\$0.84
Lost utility revenues	\$0.00	\$0.00	\$0.00	\$0.00	\$0.39	\$0.81
Valley MUD #2						
Monetary value of domestic water shortages	\$0.00	\$0.00	\$0.15	\$2.16	\$6.56	\$7.18
Lost income from reduced commercial business activity	\$0.00	\$0.00	\$0.00	\$0.00	\$0.00	\$0.50
Lost jobs due to reduced commercial business activity	0	0	0	0	0	20
Lost state and local taxes from reduced commercial business activity	\$0.00	\$0.00	\$0.00	\$0.00	\$0.00	\$0.08
Lost utility revenues	\$0.00	\$0.00	\$0.19	\$0.43	\$0.69	\$0.94
Webb County Water Utility						
Monetary value of domestic water shortages	\$0.07	\$1.26	\$3.01	\$5.05	\$9.28	\$14.37
Lost utility revenues	\$0.08	\$0.28	\$0.49	\$0.72	\$0.98	\$1.25
Weslaco						
Monetary value of domestic water shortages	\$0.00	\$0.00	\$0.00	\$0.00	\$0.47	\$1.93
Lost utility revenues	\$0.00	\$0.00	\$0.00	\$0.00	\$1.02	\$3.33

Appendix H

**James Bene PowerPoint:
November 20, 2013 GMA 13 Meeting**

Discussion of Current DFCs and Potential Alternatives

Presented by:
James Bené, P.G.

Groundwater Management Area No. 13

November 21, 2013



1

Presentation Outline

1. Current DFCs/MAGs and some of their shortcomings
2. What is “drawdown” – why it is important to distinguish between the different types
3. What makes a good DFC?
4. Alternative DFCs and their advantages



2

Current DFC/MAG Process

1. Predict pumpage locations and amounts
2. Model the predicted pumpage
3. Accept model results as DFCs
4. Predicted pumpage becomes MAG

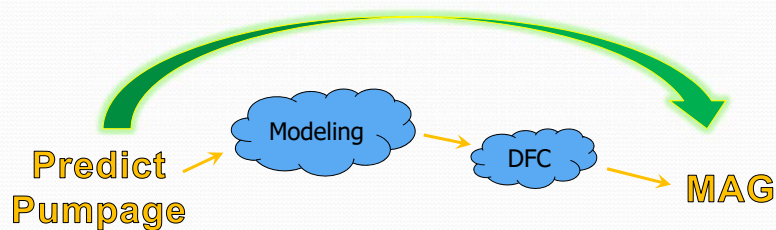

Drawbacks of Current DFCs

1. DFCs are based on simulated response model pumpage inputs instead of aquifer conditions
 - Model inputs are educated guesses for the next ½ century:
 - Pumpage/project locations, rates, and schedules
 - Cannot be correct
 - Difficult to justify model results as a regulatory limit?

Drawbacks of Current MAGs

2. The MAGs do not correspond to physical/actual groundwater availability
 - MAGs are DFC model input pumpage
 - MAGs must be treated as physical/actual groundwater availability in regional and state water plans
 - Create stakeholder confusion
 - the distinction between the current MAGs and physical groundwater availability not widely recognized

WATER
RESOURCES

5

Drawbacks of Current DFCs

3. Current DFCs are based on non-specific “drawdown”
 - There are two very different types of drawdown
 1. Water table
 2. Artesian pressure
 - They are not interchangeable (apples and oranges)

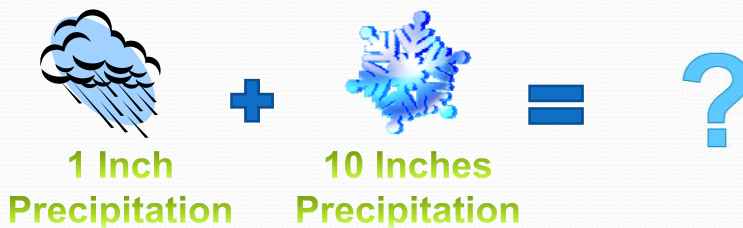

WATER
RESOURCES

6

Drawdown as a DFC

- Drawdown must be “translated” into meaningful information:
 - Will the drawdown result in aquifer depletion or unwanted environmental impacts?
 - The acceptability of drawdown always depends on other factors (saturated thickness, hydraulic boundaries, aquifer structure, etc.)

100 Feet Drawdown = **Good, Bad, Ugly?**

**ENVIRONMENTAL
CORPORATE**

7

What is Drawdown?

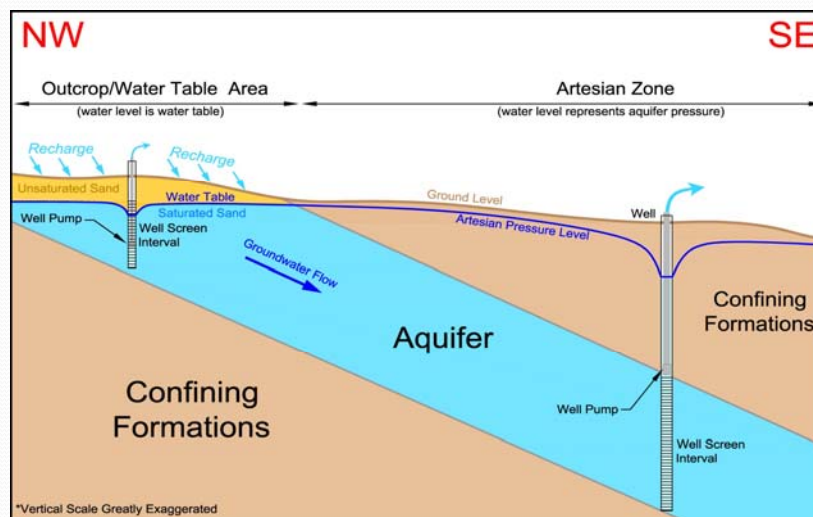

**ENVIRONMENTAL
CORPORATE**

8

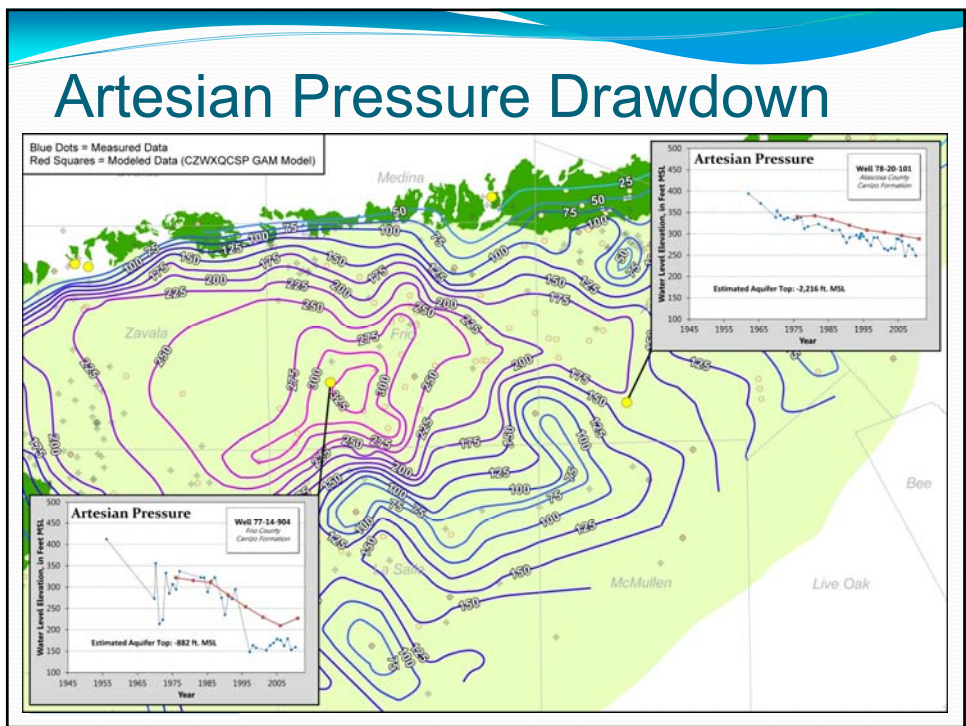
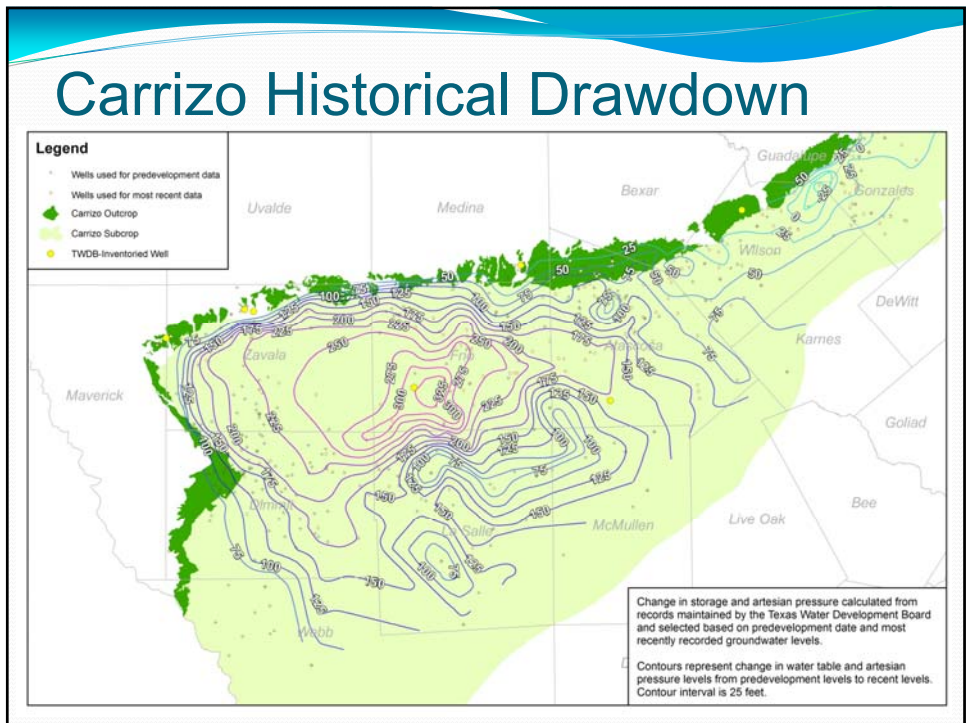

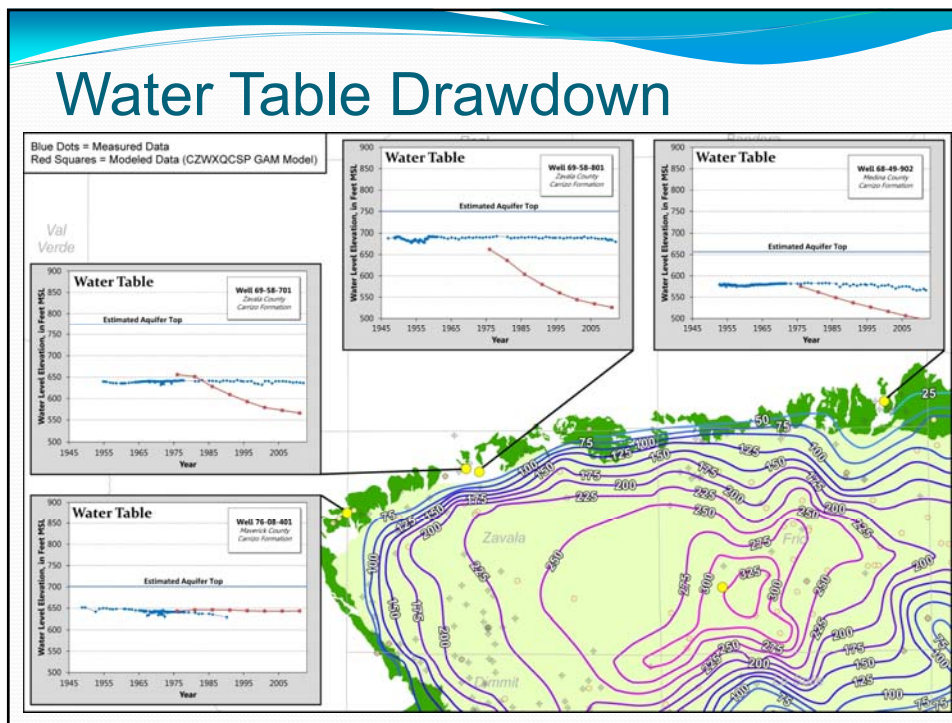

What Makes a Good DFC?

- Should succinctly and directly address core issues:
 - **Resource Depletion** – Will there be enough groundwater for future needs?
 - **Environmental Impacts** – Will pumping harm the aquifer system or ecosystems that depend on groundwater?
 - **Economic Concerns*** – What are the costs vs. benefits of groundwater use?

Alternative DFCs

1. Aquifer Storage DFC –

Specify the acceptable amount of water in aquifer storage through time.

“At least 95% of the groundwater currently stored in the aquifer should remain in storage in 50 years.”

2. “Spotlight” DFC –

Select conditions for specific areas or features that are uniquely affected by groundwater flows or effects.

“The flow from Clearwater Spring shall be maintained at rate of at least ten cubic feet per second over the next 50 years.”

Alternative DFCs

• Aquifer Storage DFCs –

- Directly address resource depletion
- Verified through water table monitoring
- Slow, predictable response

• “Spotlight” DFCs –

- Directly address environmental concerns
- Straightforward monitoring
- Careful cost/benefit analysis needed to justify
- More difficult to implement fairly

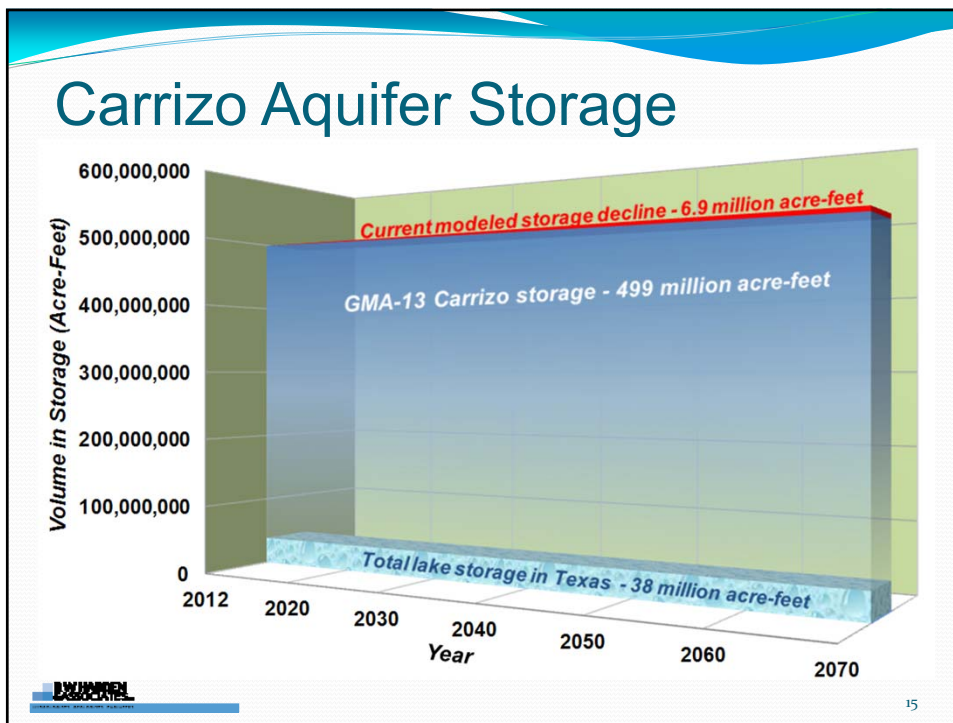

DFC Comparison

<p>Current Model-Based DFCs</p> <ul style="list-style-type: none"> • Do not directly address aquifer depletion or environmental concerns • Based only on modeling incorporating educated guesses of future pumpage • Tied to unique simulation: inflexible planning and permitting 	<p>Alternative DFCs</p> <ul style="list-style-type: none"> • Directly address aquifer depletion or environmental concerns • Based on assessment of resource availability and environmental protection • Tied to overall groundwater availability: flexible planning and permitting
--	--

DFC Comparison, Cont.

Current Model-Based DFCs

- Non-specific “drawdown” difficult to monitor/calculate in the real-world
- Limits difficult to justify
- Harder to understand what MAGs actually represent

Alternative DFCs

- Monitoring is relatively straightforward
- Limits much easier to justify
- Easier to understand what MAGs actually represent

DWYER
CORPORATE

17

Conclusions

- DFCs and MAGs play an extremely influential role in Texas’ response to current and future demands
 - Sets pumping cap for regional and State water plans
 - Determines which projects (strategies) Texas will approve and fund
 - Act as permitting cap on GCD level
- The current methods of selecting/adopting DFCs have fundamental drawbacks associated with them

DWYER
CORPORATE

18

Conclusions, Cont.

- There are other options to be considered –
 - the DFCs can and should be improved
 - We have time, there is no pressing deadline requiring action

Discussion

More detailed article available:
James.Bene@RWHarden.com
512-345-2379

Appendix I

**GBRA letter of February 26, 2016
Regarding Surface Water Impacts**

February 24, 2016

Mr. Greg Sengelmann, Administrator, Groundwater Management Area 13
Gonzales County Underground Water Conservation District
P.O. Box 1919
Gonzales, Texas 78629

Dear Mr. Sengelmann and Members of the GMA-13 Planning Committee:

The Guadalupe-Blanco River Authority (GBRA) is submitting this letter for consideration by the GMA-13 Planning Committee during its scheduled February 25, 2016 meeting. We are very interested in further discussion of the draft Desired Future Conditions (DFCs) and provide the following summary of our assessment for the Committee's consideration. As you and the Committee know, GBRA's primary concerns are associated with surface water / groundwater interactions through which new DFCs allowing greater production and drawdown will reduce streamflow and adversely affect surface water rights and environmental flows in the Guadalupe and San Antonio River Basins, as well as freshwater inflows to the Guadalupe Estuary.

This letter focuses on six major subjects of discussion, including:

- 1) Cumulative Effects in the 2016 Region L Water Plan,
- 2) Review of GMA-13 Technical Memorandum 16-01 Draft 1,
- 3) Streamflow Decreases during Low-Flow Conditions,
- 4) Review of Global Southern GAM Water Budget,
- 5) TWDB Study of Hydrology and Geology of the Confined and Unconfined Aquifers of Texas as Required by House Bill 1232, and
- 6) Conclusions and Requests

Cumulative Effects in the 2016 Region L Water Plan

The 2016 South Central Texas Regional Water Plan includes a cumulative effects analysis through which the regional water planning group and the interested public may assess the potential effects of plan implementation on water resources of the state. This cumulative effects analysis is presented in Chapter 6.1 of the regional plan and includes a summary of surface water / groundwater flux changes associated with implementation of recommended water management strategies in Table 6-2. Excerpts from Table 6-2 relevant to the Carrizo-Wilcox Aquifer are included in Table 1 below which lists the Baseline Flux, Flux with Plan, and Streamflow Changes for watersheds intersecting GMA-13.

Main Office: 933 East Court Street ~ Seguin, Texas 78155
830-379-5822 ~ 800-413-4130 ~ 830-379-9718 fax ~ www.gbra.org



GBRA

Guadalupe-Blanco River Authority
flowing solutions

Table 1. Cumulative Effects of 2016 Region L Water Plan in GMA-13

Watershed	Baseline Flux (cfs)	Flux with Plan (cfs)	Streamflow Change (cfs)
San Antonio River	14.5	24.3	-9.8
Cibolo Creek	-2.6	1.8	-4.4
Guadalupe River	-0.4	3.8	-4.2
San Marcos River	-11.0	8.1	-19.2
TOTAL	0.5	38.0	37.6

NOTE: A positive flux indicates leakage from the stream to the aquifer and a negative flux indicates aquifer discharging to the stream.

The Region L Plan pumpage from the Carrizo-Wilcox Aquifer for this cumulative effects analysis totals 67,434 acre-feet per year (acft/yr) in 2070, of which 84 percent is from the Carrizo and 16 percent from the Wilcox. This pumpage is from the recommended groundwater management strategies with planned well fields in Bexar, Caldwell, Gonzales, Guadalupe, and Wilson Counties and production is limited to Modeled Available Groundwater (MAG) in accordance with Texas Water Development Board (TWDB) requirements for regional water planning. The streamflow changes by watershed are related to the locations of the pumping centers for the recommended water management strategies. All together, an increase of 67,434 acft/yr (93 cfs) in pumping is expected to reduce 2070 streamflow by nearly 38 cfs. In terms of long-term streamflow averages, this 38 cfs reduction is a relatively small percentage. However, during drought conditions, this reduction would have noticeable effects on the reliability of surface water rights and maintenance of environmental flows. As a reminder, these streamflow changes are associated with the current GMA-13 DFCs and MAG estimates.

Review of GMA-13 Technical Memorandum 16-01 Draft 1

A review of GMA-13 Technical Memorandum 16-01 Draft 1 and the accompanying January 22, 2016 PowerPoint presentation was conducted in an attempt to understand the concepts and model results for Scenarios 8-12. For purposes of this letter, we are focusing on Scenario 9, which appears to be the center of discussion. Scenario 9 includes alternative groundwater water management strategies in the 2016 Region L Water Plan which are not limited to current MAG estimates. In general, Scenario 9 includes all pumping in Scenario 8 plus minor variations in the production volumes associated with alternative strategies as listed in Appendix E of the 2016 Region L Water Plan, except for the Local Carrizo (Strategy 1) which meets shortages for local water utilities. According to Table 3 in TM 16-01, the Scenario 9 pumping that is associated with Region L water management strategies totals 238,798 acft/yr. This is 3.5 times the production associated with the Region L recommended strategies which were limited by the current MAG.

Following is discussion of estimated streamflow reductions by watershed for the 2070 effects of Scenario 9 groundwater production. Reductions are estimated by: (1) assigning the Carrizo and Wilcox pumping in the recommended and Scenario 9 water management strategies to four watersheds (San Marcos, Guadalupe, Cibolo, and San Antonio) on the basis of where the pumping is projected to occur in the Region L Plan, (2) assuming a linear response of streamflow losses to increases in pumping in the

long-term (2070), (3) calculating a pumpage multiplier by dividing the Region L recommended strategy pumping into the Scenario 9 strategy pumping for each of the four watersheds, and (4) multiplying the pumpage multiplier times the change in streamflow for each of the four watersheds (fourth column in Table 1). Table 2 summarizes the resulting estimates. Please note that these are estimates based on simple concepts and assumptions. More accurate estimates could be derived by exporting results from the Scenario 9 GAM run. Changes in streamflow from the Region L Plan are not assigned to the Carrizo and Wilcox Aquifers.

Table 2. GAM Pumping and Changes in Streamflow for Four Watersheds

Watershed	Pumping (acft/yr)		Changes in Streamflow (cfs)	
	Strategies Limited by Current MAG	Scenario 9	Strategies Limited by Current MAG	Scenario 9
San Antonio River	11,041	74,054	-9.8	-65.7
Cibolo Creek	7,785	90,667	-4.4	-51.2
Guadalupe River	11,775	18,328	-4.2	-6.5
San Marcos River	36,833	55,749	-19.2	-29.1
TOTAL	67,434	238,798	-37.6	-153

There is limited information in the GMA-13 Technical Memorandum 16-01 Draft 1 and the accompanying PowerPoint presentation on gains and losses from rivers and streams. From slide 29 of the presentation, the 2070 GMA 13 water budget shows streamflow losses of 73 cfs (52,989 acft/yr) for the 2000-2011 Scenario and 153 cfs (110,881 acft/yr) in losses for Scenario 9. The amount attributable to each of the four watersheds can't be determined from the information on slide 29. Note that the aggregated estimate of 153 cfs in streamflow losses extracted from Scenario 9 GAM output and shown on slide 29 is virtually identical to the independently derived estimate of 153 cfs shown in Table 2. Also, slide 32 presents the water budget that is attributed to the Wilcox Aquifer for Scenario 9. This table shows Wilcox pumping causes a loss of 50 cfs (36,405 acft/yr) from the rivers and streams in 2070. In summary, these model results and simple calculations suggest that the Scenario 9 level of pumping would cause streamflow losses to the aquifers about 115 cfs greater than those under the current MAG.

Streamflow Decreases during Low-Flow Conditions

We have conducted a preliminary analysis to estimate potential streamflow decreases at selected locations on the major streams. These locations are downstream of the Carrizo-Wilcox Aquifer outcrop. The approach includes: (1) using the GSA WAM to calculate baseline regulated flows, (2) sorting the results by "Percent of time greater than or equal to," and (3) subtracting the estimated 2070 streamflow changes for the recommended (limited to current MAG) and Scenario 9 water management strategies from the baseline regulated flows. Regulated streamflows from the GSA WAM reflect full utilization of existing surface water rights (to the extent streamflow is available) and exclude treated wastewater as many entities have included large scale direct reuse strategies in the Region L Plan. Table 3 presents results for the 25th, 10th, and 5th percentile low flows (i.e. flows that are exceeded 75%, 90%, and 95% of the time, respectively).

Table 3. Regulated Streamflows with and without Region L Water Management Strategies

Station	Baseline Regulated Streamflows (cfs)	Regulated Streamflows with Streamflow Losses Attributable to Recommended Carrizo-Wilcox Strategies Limited to Current MAG (cfs)*	Regulated Streamflows with Streamflow Losses Attributable to Scenario 9 (cfs)*
25th Percentile Baseline Regulated Streamflow Level			
San Marcos River at Confluence with Guadalupe	160	141 (12%)	131 (18%)
Guadalupe River at Gonzales	410	387 (6%)	374 (9%)
Cibolo Creek at Falls City	17	13 (24%)	DRY (100%)
San Antonio River at Falls City	41	32 (22%)	DRY (100%)
10th Percentile Baseline Regulated Streamflow Level			
San Marcos River at Confluence with Guadalupe	87	68 (22%)	58 (33%)
Guadalupe River at Gonzales	237	213 (10%)	201 (15%)
Cibolo Creek at Falls City	10	6 (40%)	DRY (100%)
San Antonio River at Falls City	28	18 (36%)	DRY (100%)
5th Percentile Baseline Regulated Streamflow Level			
San Marcos River at Confluence with Guadalupe	64	44 (31%)	35 (45%)
Guadalupe River at Gonzales	178	155 (13%)	142 (20%)
Cibolo Creek at Falls City	7	2 (71%)	DRY (100%)
San Antonio River at Falls City	22	12 (45%)	DRY (100%)

* Percentage reduction from Baseline Regulated Flow shown in parentheses.

Of particular interest in Table 3 are significant percentage streamflow reductions during low flow times and the occurrences of dry stream conditions in streams that normally would have at least a small amount of flow. These dry conditions would occur for Scenario 9 on Cibolo Creek and the San Antonio River at Falls City more than 25 percent of the time. For all streams, the lower streamflow for the recommended and Scenario 9 conditions will affect the reliability of water rights and the maintenance of environmental flows, not only during drought, but under relatively normal conditions. GBRA is particularly concerned with the fact that our surface water rights below the confluence of the Guadalupe and San Antonio Rivers will be affected by all of the streamflow reductions discussed herein, including those on the San Antonio River and Cibolo Creek.

Review of Southern GAM Water Budget

Slide 29 of the January 22, 2016 PowerPoint presentation presents an overall model water budget of individual inflow and outflow components. Major inflow components to the aquifer for Scenario 9, besides the rivers and streams component, include: (1) General Head Boundary (GHB) leakage from the younger (overlying) geologic units into the active layers of the model, (2) From GMA-12 (underflow along the northeast model boundary), and (3) From GMA-15 (downdip zone where groundwater salinity ranges from brackish to saline). Comments are provided in Table 4.

Table 4. Selected Aquifer Water Budget Inflow for Scenario 9.

Inflow Boundary	2070 Rate of Inflow (acft/yr)	Percent of Total Inflow	Percent Compared to Total Recharge	Comment
Rivers and Streams	110,881	27.0	54.6	Discussed earlier
Recharge	203,106	49.4	-	A baseline for all simulations.
GHB	15,568	3.8	7.7	An inactive model layer above the Sparta Aquifer. Water in this layer is considered to be of poor quality
From GMA-12	40,744	9.9	20.1	This boundary condition was defined by a predictive simulation of the Central GAM about 15 years ago. The pumping in the Central GAM that was used to calculate this boundary condition is seriously out of date. Of concern, it has a great influence on model results in northeastern parts of Gonzales and Caldwell Counties.
From GMA-15	34,379	8.4	16.9	GMA-15 is southeast of Gonzales and Wilson Counties. This is an underflow of relatively high salinity groundwater in this part of the Southern GAM into the updip freshwater portion of the Carrizo. It has the potential of significantly degrading the freshwater zone near the historical interface with the saline zone.

Table 4 model results are for the entire GMA-13 model area. Effects will be much greater in the specific counties where the Region L strategy well fields are located. In reality, actual effects are expected to be much, much greater in Gonzales, Caldwell, Guadalupe, Wilson, and Bexar Counties than in other GMA-13 counties.

TWDB Study of Hydrology and Geology of the Confined and Unconfined Aquifers of Texas as Required by House Bill 1232

TWDB staff prepared a memorandum dated January 7, 2016 to the TWDB Board regarding a required study of the hydrology and geology of the confined and unconfined aquifers of Texas pursuant to House Bill 1232 of the 84th Texas Legislature. Following solicitation of stakeholder input, the TWDB staff has scoped the study to include:

- Minimum rate at which an aquifer must contribute to another aquifer to be considered “tributary,” and
- Minimum rate at which an aquifer must contribute to the surface flow of a stream to be considered “tributary.”

For the latter, the TWDB staff recommends the study to include outcrop areas of major and minor aquifers where:

“The minimum flow rate criteria is defined as discharge from major and minor aquifers contributing 0.1 percent of the mean annual surface water flow over any specified geographic area of any major or minor aquifer.”

Application of these criteria to selected long-term gaging is presented in Table 5.

Table 5. Long-term Daily Streamflow Averages and Application of TWDB Staff Recommended Criteria

Gaging Station	Average Daily Streamflow, 1940-2015 (cfs)	TWDB Study Criteria (cfs)
08172000 San Marcos-Luling	413	0.41
08176500 Guadalupe-Victoria	1,930	1.93
08183500 San Antonio-Falls City	531	0.53
08186000 Cibolo-Falls City	145	0.14

Comparing the streamflow reductions in Tables 1 and 2 above to the TWDB “tributary” criteria for study in Table 5, the Carrizo-Wilcox Aquifer and probably the Sparta and Queen City Aquifers will meet the study criteria. In fact, the potential streamflow reductions associated with Scenario 9 groundwater production are almost 2 orders of magnitude greater than the TWDB “tributary” criteria for study. It is unknown how future Texas Legislatures will act on the results from these TWDB studies, but it is GBRA’s hope that surface water rights and environmental flows will be protected from the adverse effects of excessive groundwater production.

Conclusions and Requests

GBRA urges that GMA-13 seriously consider our findings and concerns regarding:

- 1) Significant reductions in streamflow associated with potential use of Scenario 9 as the basis for adoption of new DFCs,
- 2) Significant effects of such reduced streamflow on current water rights and environmental flows,
- 3) Induced inflow of poor quality groundwater into the Carrizo Aquifer, and
- 4) Potential state regulation of the effects of groundwater pumping on streamflow.

Mr. Greg Sengelmann
February 24, 2016
Page Seven

GBRA respectfully requests that the GAM-13 Planning Committee reject Scenario 9 and readopt the current DFCs or adopt DFCs that are at least equally protective of surface water rights and environmental flow needs.

Sincerely,

A handwritten signature in blue ink, appearing to read "W. West, Jr.", with a stylized flourish at the end.

William E. West, Jr.
General Manager
Guadalupe-Blanco River Authority

Appendix J

**James Beach PowerPoint: March 30, 2016 Regarding Modeling
Groundwater-Surface Water Interactions**

Historical Data and Modeling of Groundwater Surface water Interaction

by

James Beach, P.G.
LBG-Guyton Associates

March 30, 2016

Stream-aquifer interaction

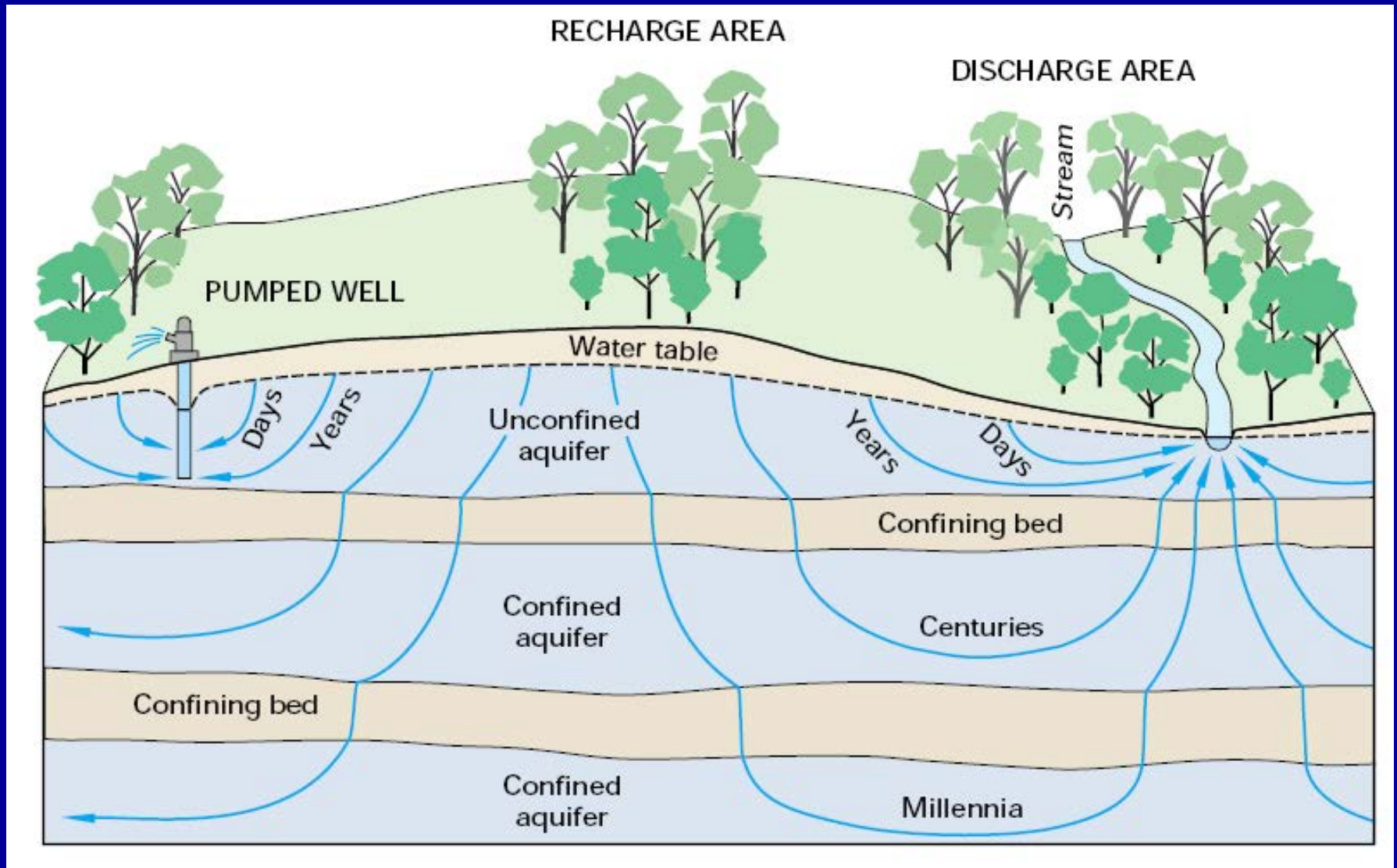

after USGS

Stream-aquifer interaction

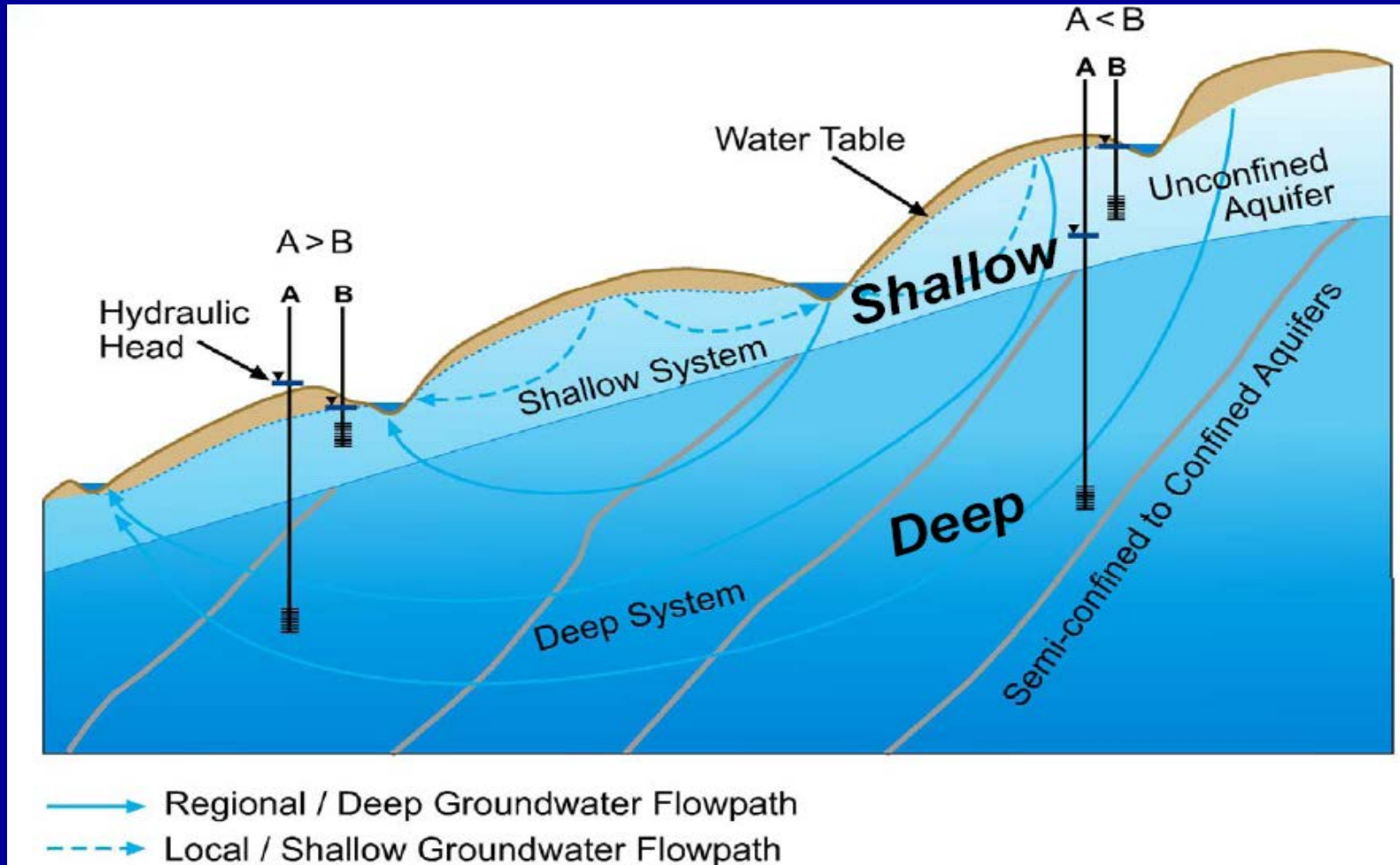

after LCRA

Evergreen UWCD Monitoring Wells and Irrigated Areas

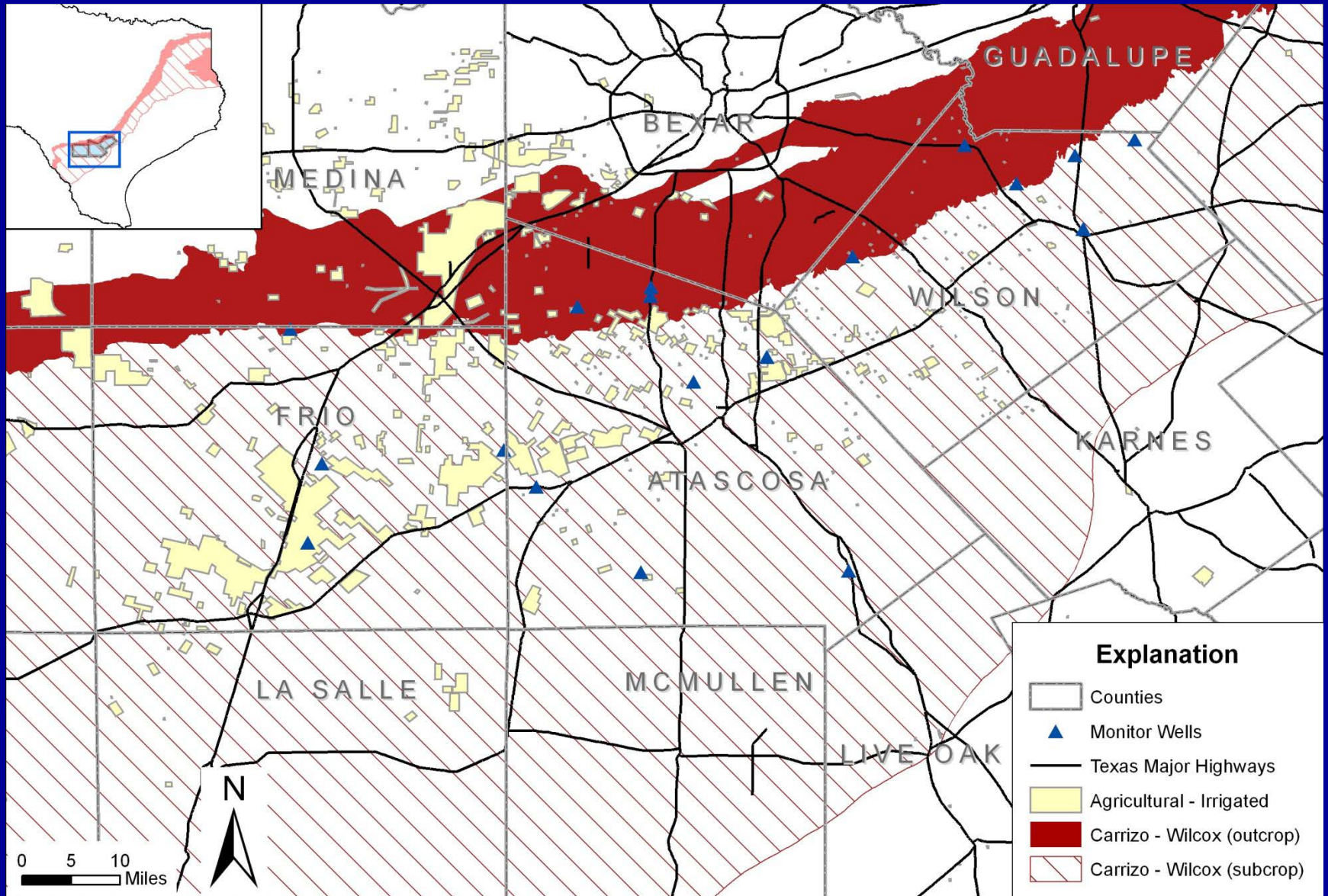

Frio County Monitoring Wells

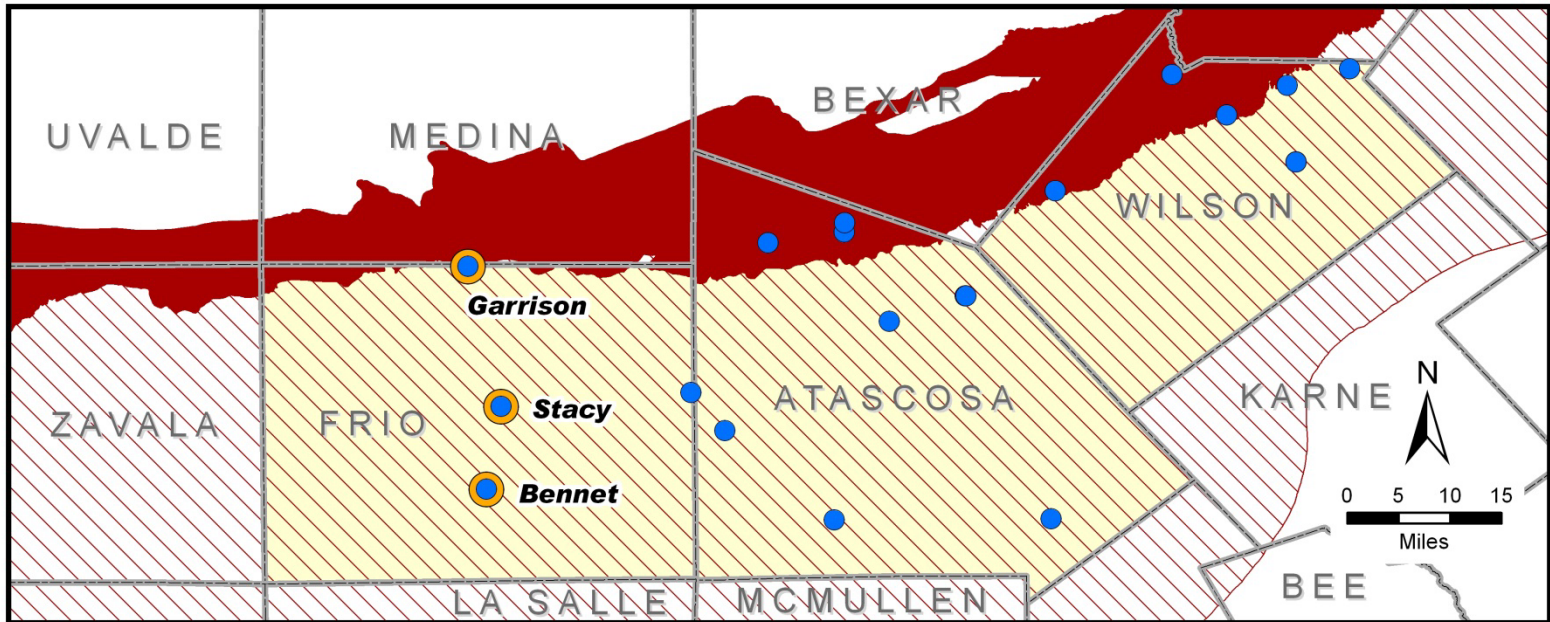

Explanation

- Monitoring Well
- Frio County Hydrograph Well
- Carrizo - Wilcox (outcrop)
- Carrizo - Wilcox (subcrop)

FRIO COUNTY



LBG-Guyton Associates

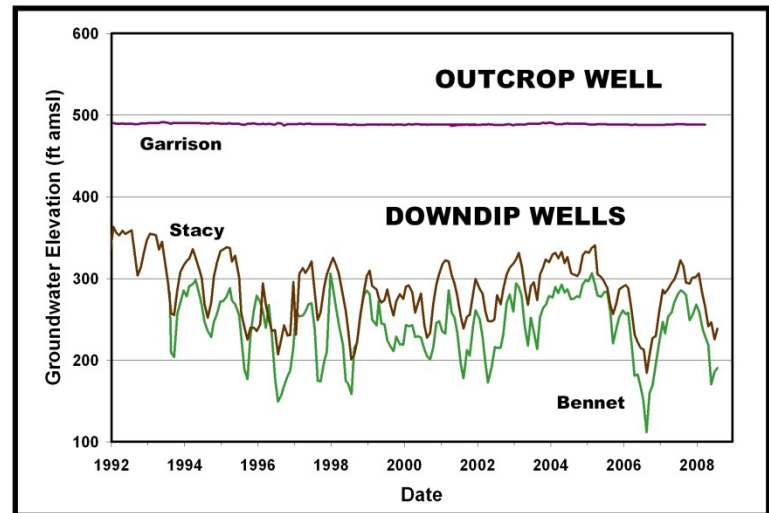

Frio County Monitoring Well Hydrographs

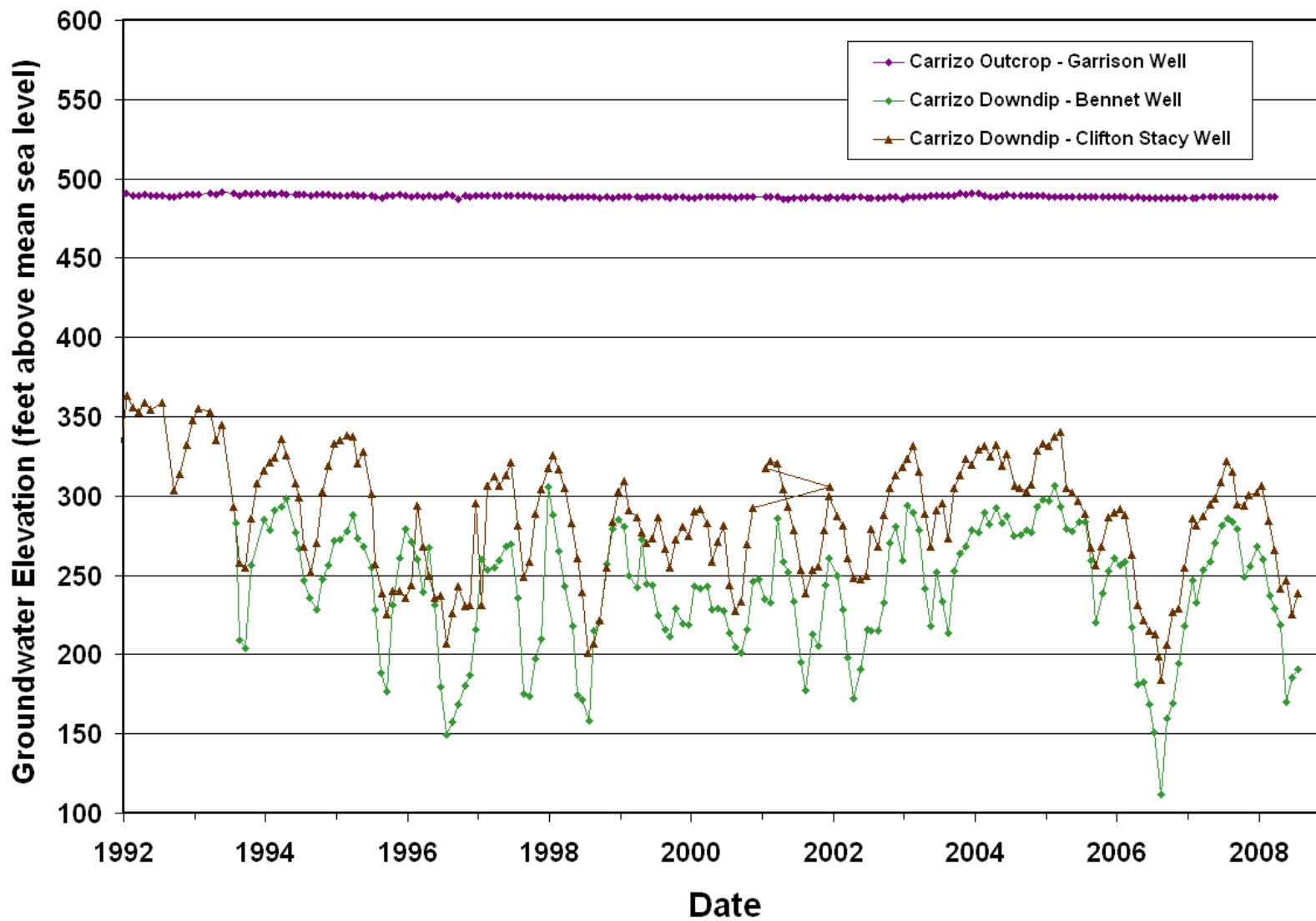

Atascosa County Monitoring Wells

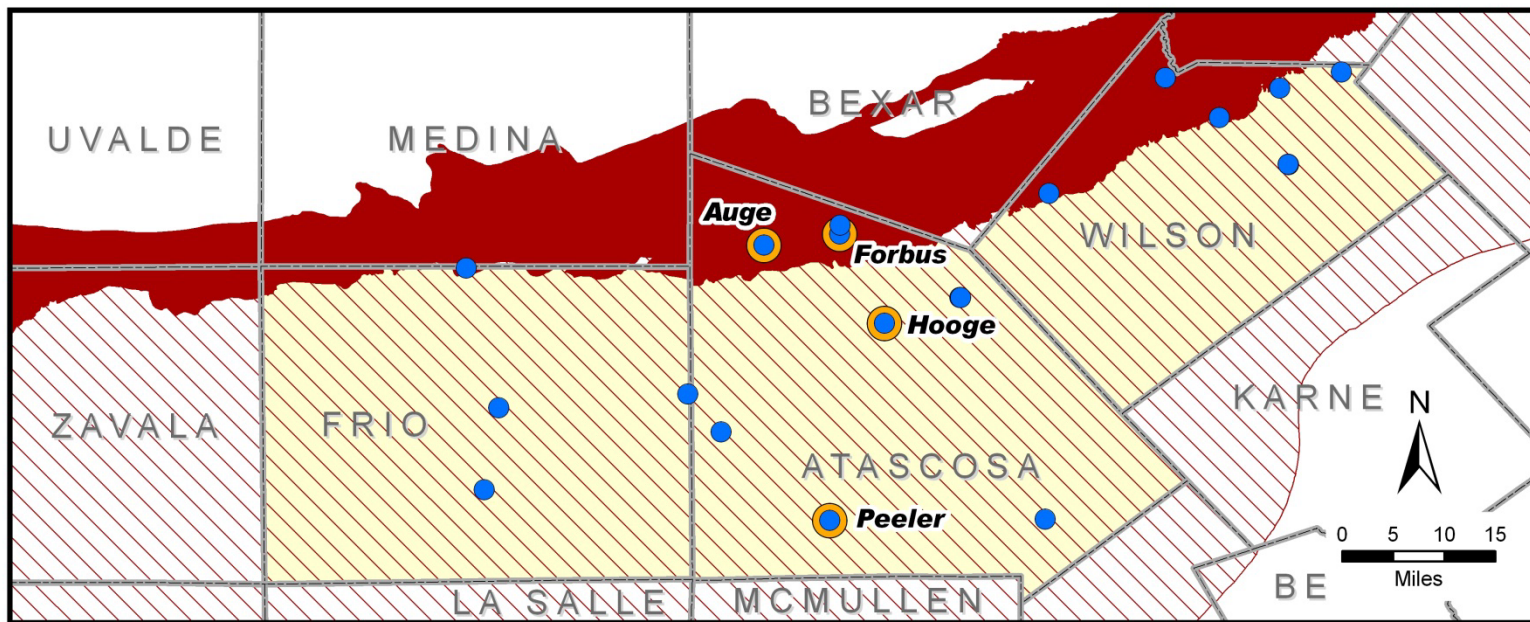

Explanation

- Monitoring Well
- Atascosa County Hydrograph Well
- Carrizo - Wilcox (outcrop)
- Carrizo - Wilcox (subcrop)

ATASCOSA COUNTY



LBG-Guyton Associates

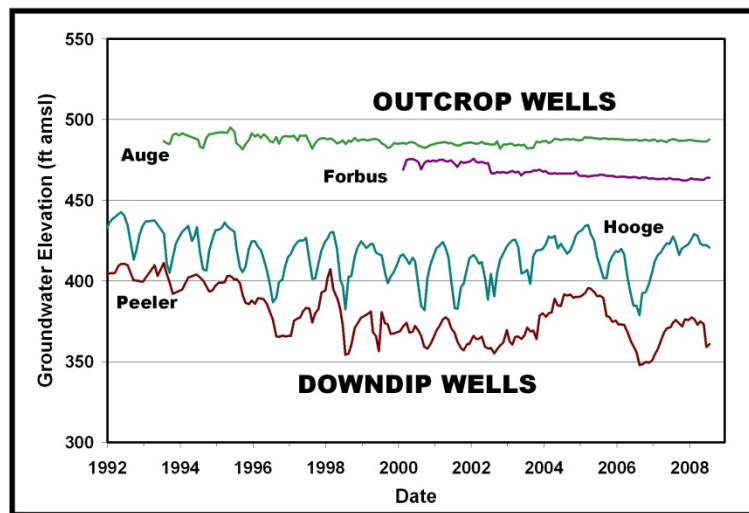

Atascosa County Monitoring Well Hydrographs

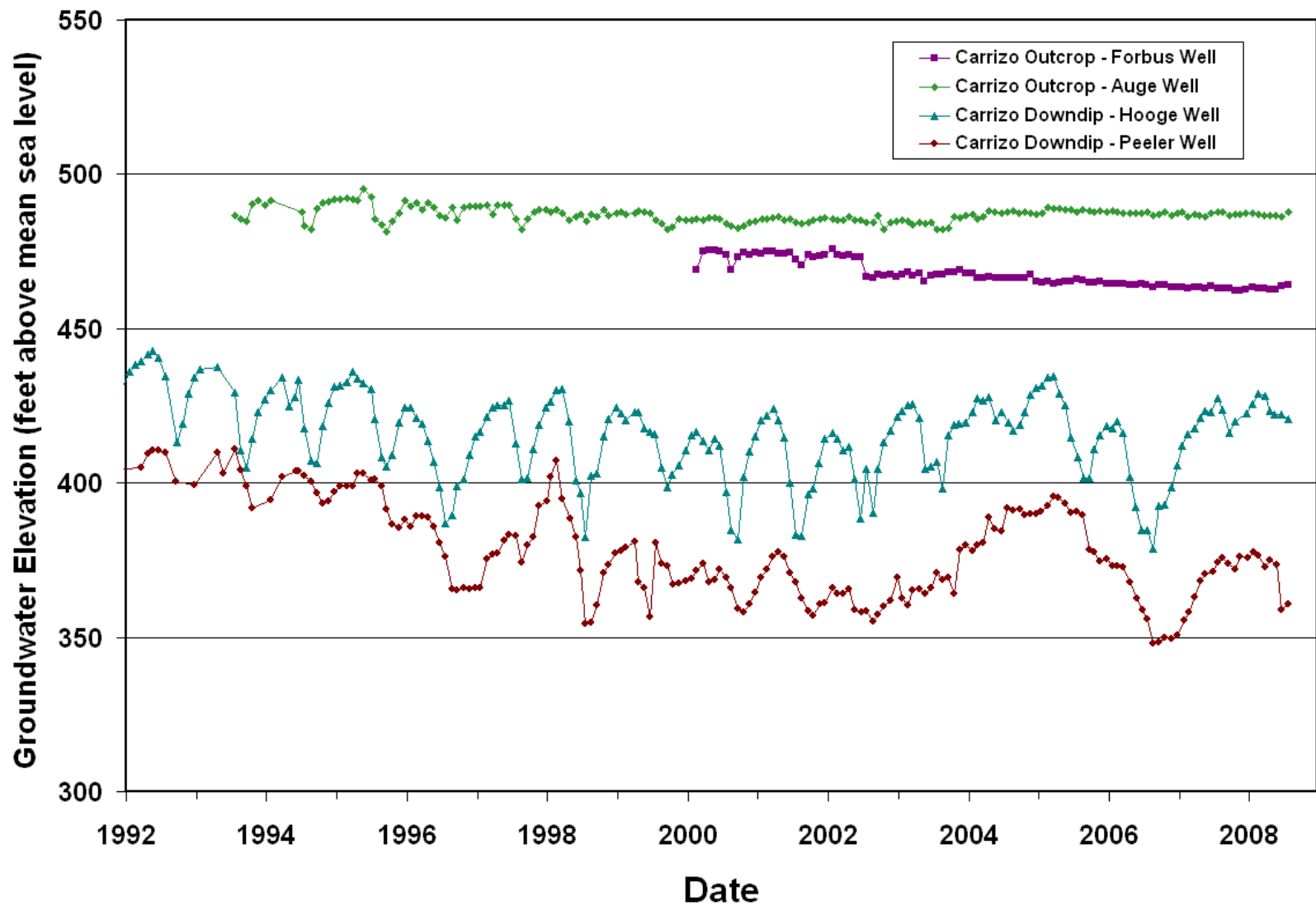

Carrizo Outcrop Well Hydrographs Frio And Medina Counties

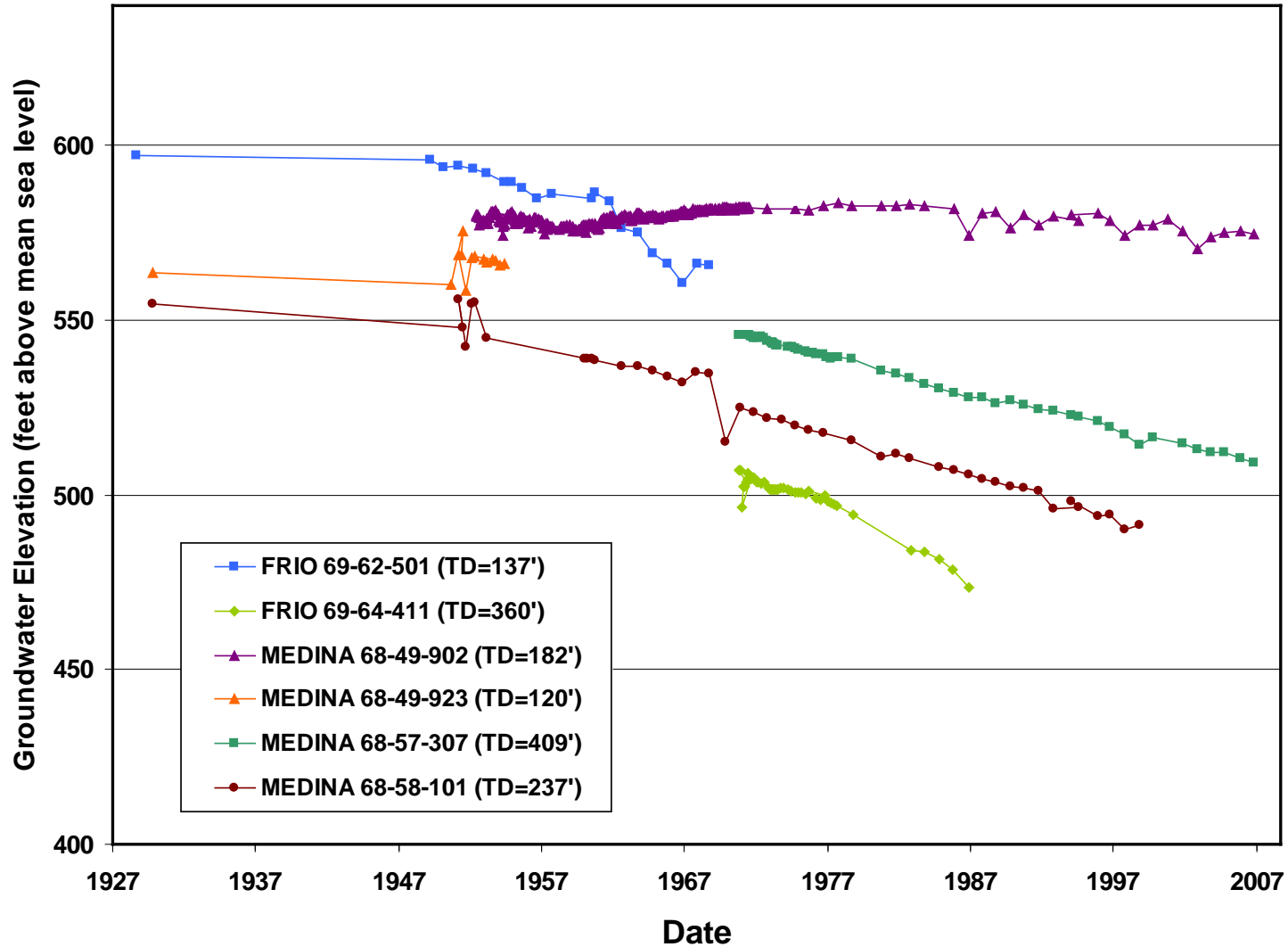

Carrizo and Wilcox Aquifers in Texas

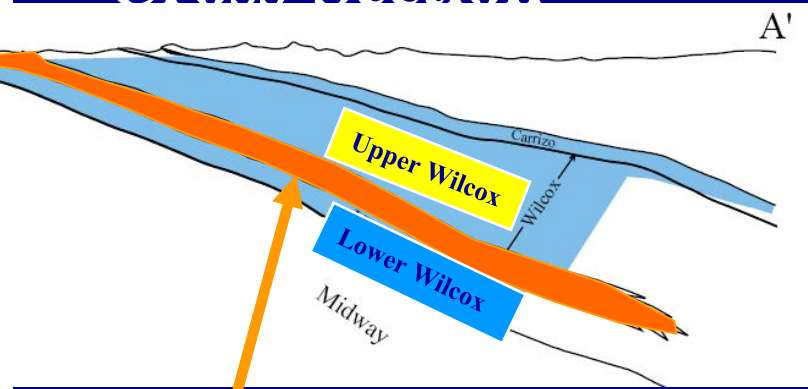
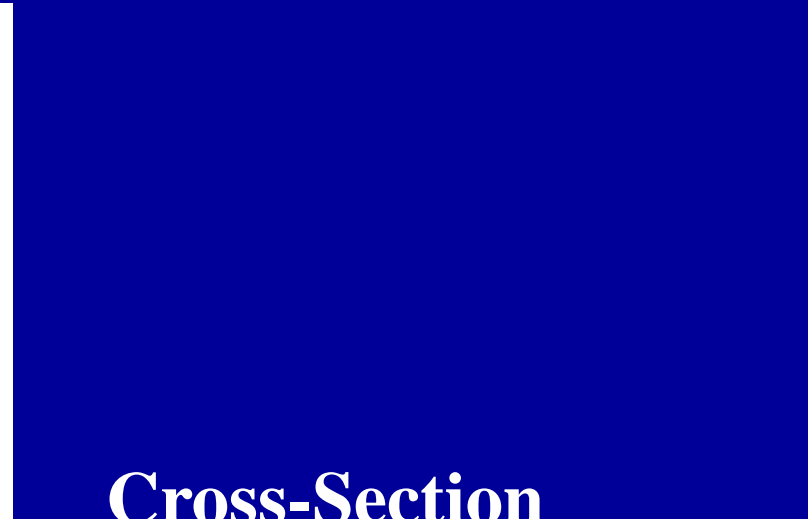
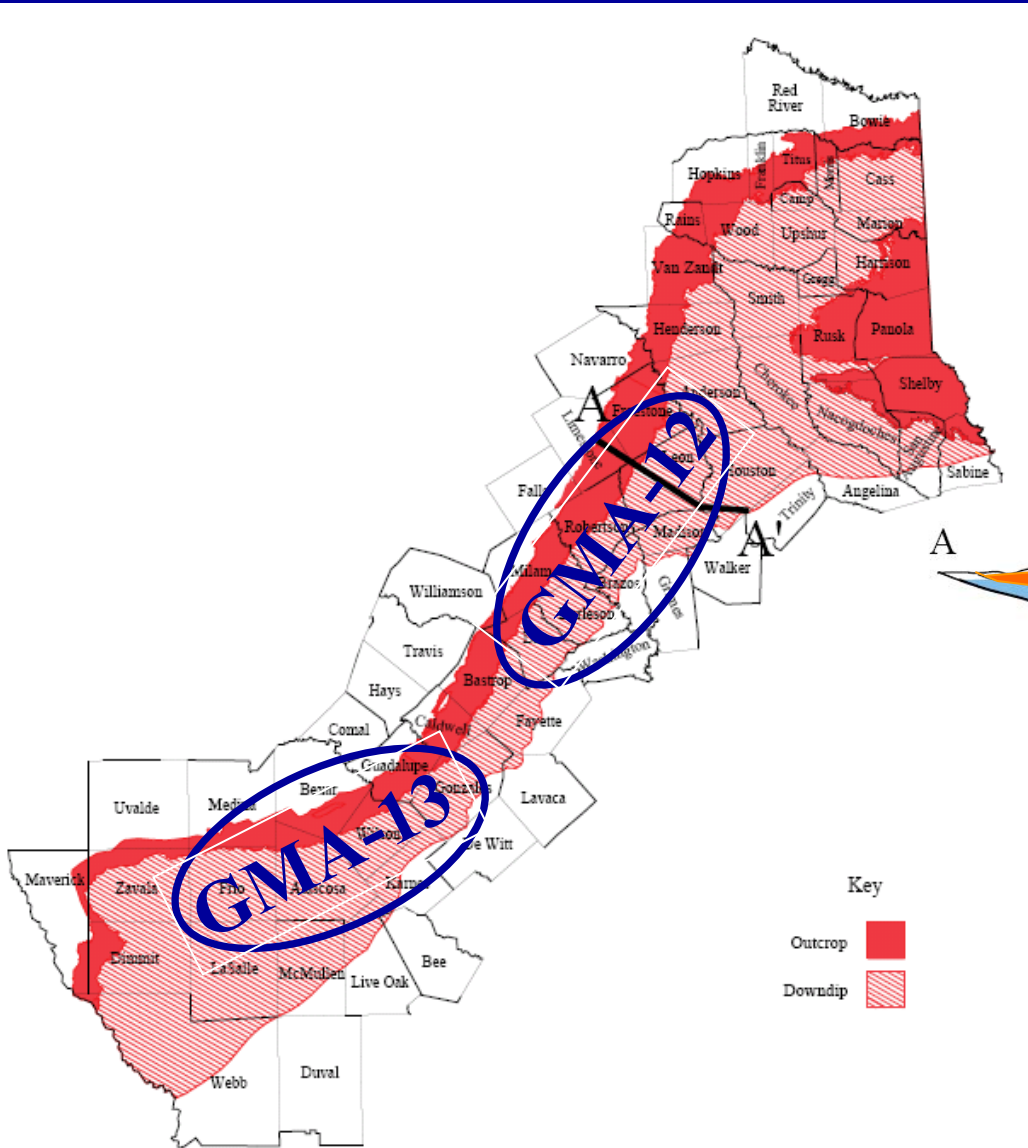

Middle Wilcox

Wilcox Aquifer Well Locations

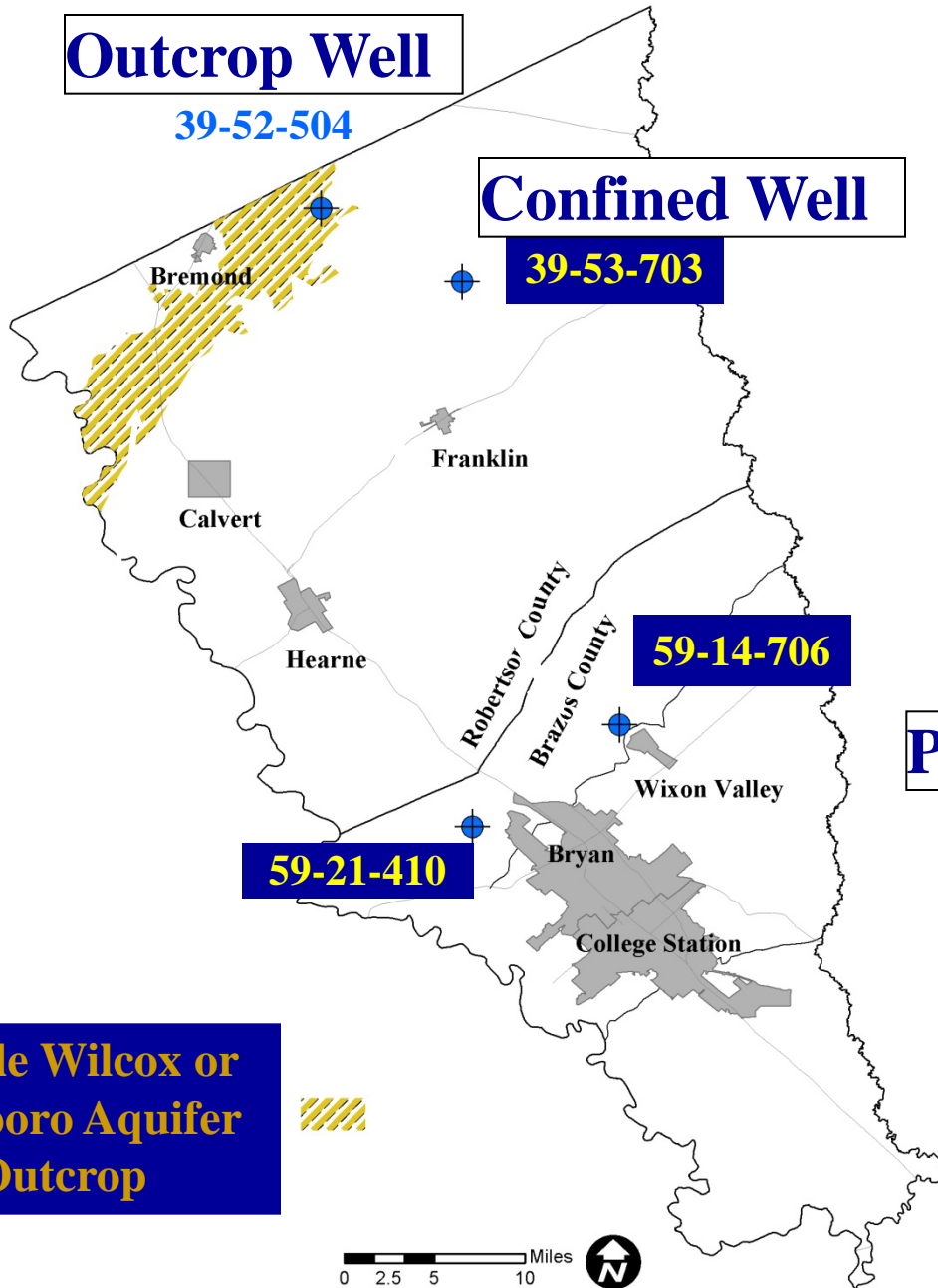

Pumping Wells

**Middle Wilcox or
Simsboro Aquifer
Outcrop**

Outcrop and Downdip Hydrographs in Brazos and Robertson Counties

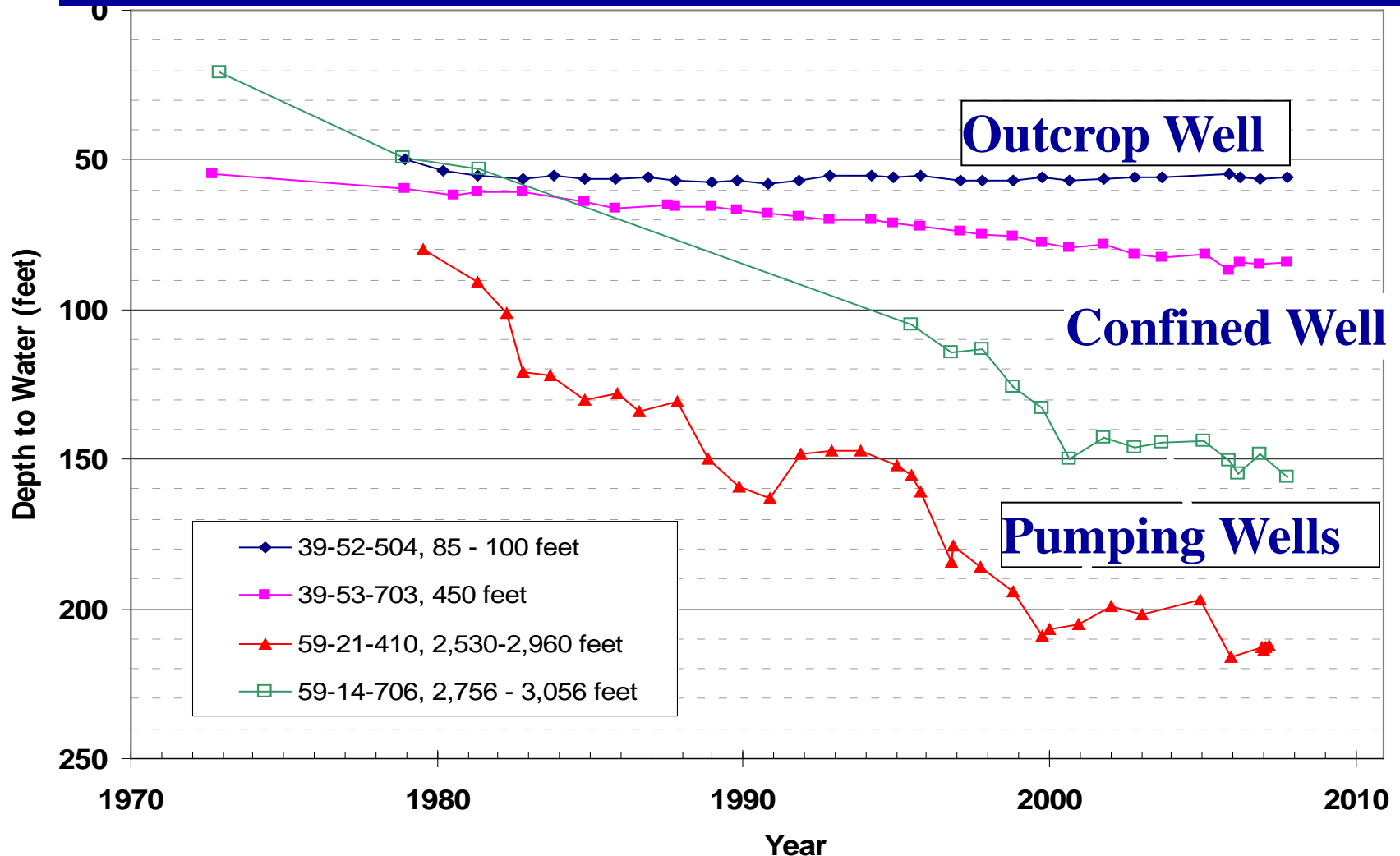

Outcrop Hydrology

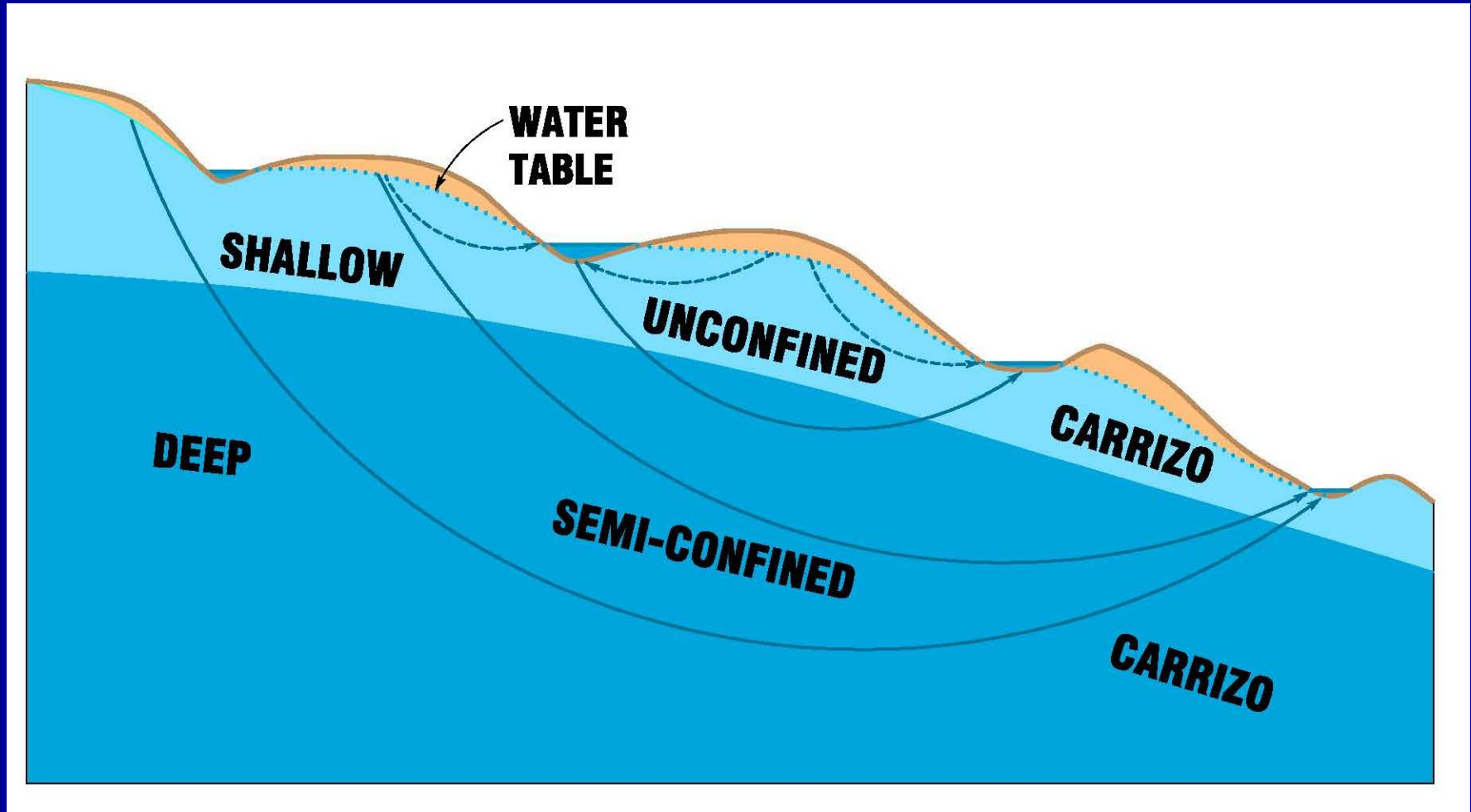

Current QCSGAM vertical discretization

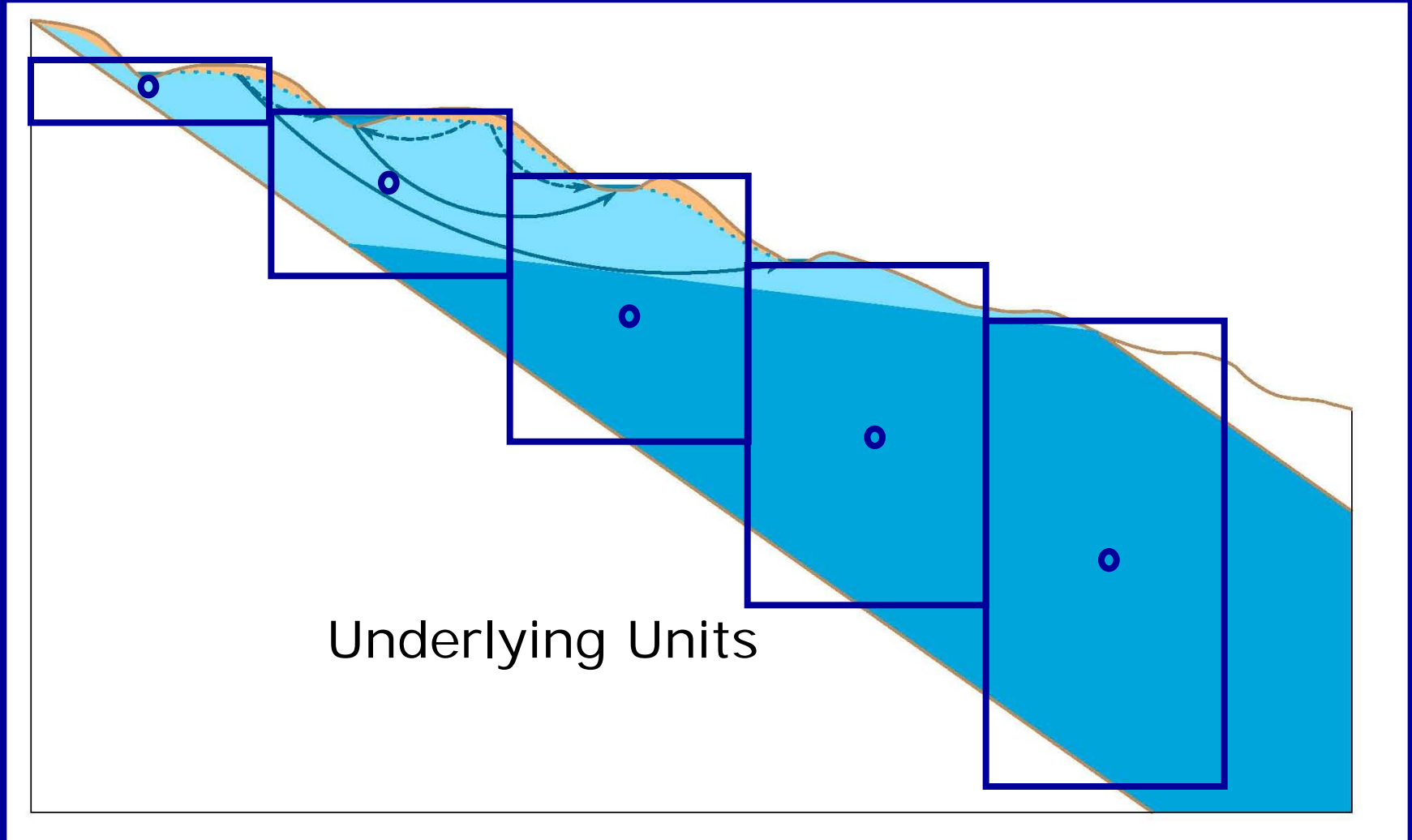

Model construction affects how models simulate GW-SW interaction

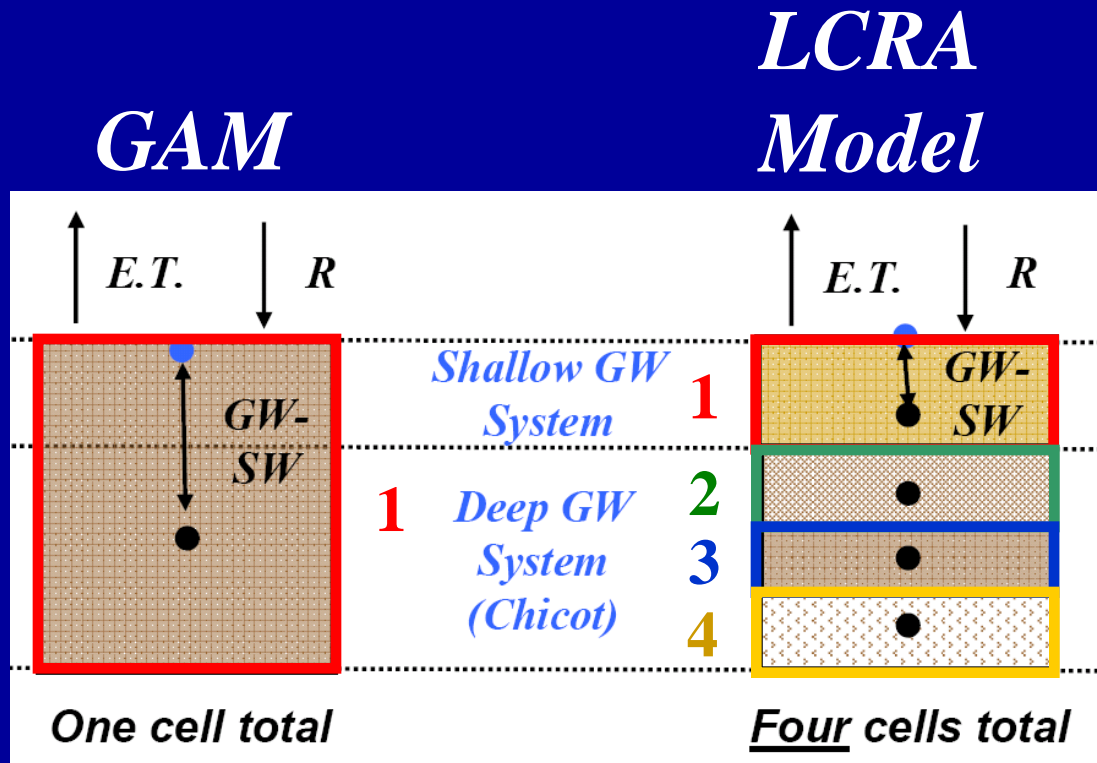

Findings

- Modeling thick aquifers with one vertical cell limits accuracy of SW-GW interaction
- One-cell model over-estimated stream impact from deep production