



**ESPEY,
HUSTON &
ASSOCIATES, INC.**
Engineering & Environmental Consultants

Document No. 900590
EH&A Job No. 12512

**FINAL REPORT
MASTER DRAINAGE STUDY
LONGVIEW, TEXAS**

Prepared for:

**City of Longview
Longview, Texas**

Mayor

Lou Galosy

City Manager

Jim Baugh

City Council

Tom Hayes

G.A. McLaughlin

Mark Pruitt

Martha Whitehead

Joan N. Berry

James W. Hunt

**Director of Planning & Operations
Ed Rohner**

**Director of Public Works
W.A. Johnston, P.E.**

**Public Works Engineer
Harold M. Barr, P.E.**

**Utilities Engineer
Ken E. Gill, P.E.**

**Prepared by:
Espey, Huston & Associates, Inc.
P.O. Box 519
Austin, Texas 78767**

January 1991

TABLE OF CONTENTS

<u>Section</u>		<u>Page</u>
	List of Figures	iv
	List of Tables	v
	Acknowledgements	vi
	Executive Summary	1
1.0	<u>INTRODUCTION</u>	1-1
1.1	STUDY AREA DESCRIPTION	1-1
1.2	STUDY BACKGROUND	1-3
1.3	GOALS AND OBJECTIVES	1-4
1.4	GUIDE TO THE REPORT	1-5
2.0	<u>MASTER PLANNING OVERVIEW</u>	2-1
2.1	IDENTIFICATION OF PROBLEMS AND NEEDS	2-1
2.2	DEVELOP ALTERNATIVE SOLUTIONS	2-1
2.3	PLAN DEVELOPMENT	2-2
3.0	<u>IDENTIFICATION OF DRAINAGE-RELATED PROBLEMS AND NEEDS</u>	3-1
3.1	REGULATORY FRAMEWORK AND MAINTENANCE REQUIREMENTS	3-1
3.2	EROSION AND SEDIMENTATION	3-4
3.3	DRAINAGE AND FLOODING CONDITIONS	3-5
3.3.1	<u>Minor System Conditions</u>	3-7
3.3.2	<u>Major System Conditions</u>	3-7
3.3.2.1	Analysis of Base Hydrologic Conditions	3-8
3.3.2.2	Determination of Base Flood Elevations	3-15
3.4	TEST OF MODELING TECHNIQUES USING HIGH WATER MARKS FROM THE MARCH 28-29, 1989 FLOOD EVENT	3-25
4.0	<u>ANALYSIS OF ALTERNATIVE SOLUTIONS</u>	4-1
4.1	DELINEATION OF STUDY REACHES	4-1
4.2	EVALUATION FACTORS	4-2

TABLE OF CONTENTS (Concluded)

<u>Section</u>		<u>Page</u>
4.3	SCREENING (SELECTING) POTENTIAL ALTERNATIVE SOLUTIONS	4-4
4.4	EVALUATION OF SELECTED ALTERNATIVE SOLUTIONS	4-12
4.4.1	<u>Channel, Roadway Crossings and Small Problem Areas Design</u>	4-13
4.4.2	<u>Regional Stormwater Detention Facilities</u>	4-22
4.4.3	<u>Acquisition</u>	4-35
4.4.4	<u>Floodplain Dedication</u>	4-35
4.4.5	<u>No Action</u>	4-36
5.0	<u>RECOMMENDED MASTER PLAN</u>	5-1
6.0	<u>REFERENCES</u>	6-1
	APPENDIX A Detailed Description of Hydrologic (HEC-1) Modeling Methods	
	APPENDIX B Channel Design Feature Tables	
	APPENDIX C Quantity and Cost for Channel and Roadway Crossing Improvements	
	APPENDIX D Determination of Small Problem Area Design Solutions	
	APPENDIX E Overview of Funding Options	

LIST OF FIGURES

<u>Figure</u>		<u>Page</u>
1-1	Vicinity Map	1-2
3-1	Hydrologic Schematic - Grace, Iron Bridge and Eastman Lake Creeks	3-11
3-2	Hydrologic Schematic - Hawkins Creek	3-12
4-1	Watershed Study (Design) Reaches	4-3
4-2	Typical Design Channel Cross Section	4-16
4-3	Grace Creek Watershed Hydrologic Prioritization	4-20
4-4	Eastman Lake Creek, Iron Bridge Creek, and Hawkins Creek Watersheds Hydrologic Prioritization	4-21

LIST OF EXHIBITS

<u>Exhibit</u>		<u>Page</u>
A	Study Area Watersheds	3-10
B	Detention Study Area	4-30

LIST OF TABLES

<u>Table</u>		<u>Page</u>
3-1	Summary of HEC-1 Peak Discharges	3-13
3-2	Stream Reaches Included in HEC-2 Models	3-16
3-3	FEMA HEC-2 Model Updates for Master Drainage Study	3-18
3-4	Storm Rainfall Analysis, 28-29 March 1989 Storm	3-26
3-5	HEC-1/HEC-2 Model Verification Using 28-29 March 1989 Flood High Water Marks	3-28
4-1	Alternative Solutions to Drainage Problems	4-5
4-2	Priority Listing for Improvements Related to Channels, Roadway Crossings and Minor Drainage	4-23
4-3	Preliminary Stormwater Detention Feasibility Analysis (Peak Discharge Comparison), Grace Creek Watershed	4-31
4-4	Final Stormwater Detention Feasibility Analysis (Peak Discharge Comparison), Grace Creek Watershed	4-34

ACKNOWLEDGMENTS

Development of this Master Drainage Plan for the City of Longview was accomplished with the cooperation and assistance of numerous capable individuals. Espey, Huston & Associates, Inc. would like to acknowledge our team members who assisted greatly in the Master Plan development. Our team members included the Hart Engineering Company (assisted by Harle Engineering Company), KSA Engineers, Inc. and Walsh-Morris Engineering Company, Inc. We would like to express our appreciation to Mr. Robert Wear and others at the Texas Water Development Board for their assistance throughout the project. This study was partially funded by a Texas Water Development Board grant.

Our most sincere appreciation goes to the very capable individuals at the City of Longview who participated in the Master Plan development process from its inception to the completion of this final report. The following City personnel are to be especially commended for their efforts:

James B. Baugh, City Manager
Jo Ann H. Metcalf, City Secretary
Larry W. Schenk, City Attorney
W. Andrew Johnston, P.E., Director of Public Works
Ed Rohner, Director of Planning and Zoning
Harold M. Barr, P.E., Public Works Engineer
Kenneth E. Gill, P.E., Utilities Engineer

EXECUTIVE SUMMARY

INTRODUCTION/BACKGROUND

The primary purpose of the study is to develop a flexible and dynamic master plan that establishes the location and nature of existing and potential future drainage-related problems, evaluates various structural and nonstructural solutions to these problems and proposes a plan for prioritizing and implementing the needed improvements, institutional actions and regulatory adjustments to solve those problems. The plan's flexibility is of primary importance to allow for future conditions and considerations as well as to efficiently utilize available city financial resources.

The study area generally covers the approximately fifty (50) square miles within the city's corporate boundary and certain adjacent areas (approximately 25 square miles) that drain into the city as shown in Figure 1-1 of the report. In the past flooding has occurred during localized thunderstorms but the worst flooding has been caused by frontal-type storms that generally occur during the spring and fall. The floods that occurred in April 1966 and March 1989 caused extensive damage in Longview with several casualties being reported as a result of the 1966 event. These storms have caused problems along the many "major" as well as "minor" drainageways within the city.

Following the two floods in the spring of 1989, the city proposed the development of a master drainage study to develop a plan of action to combat the flooding problems. Although there are numerous important elements to the overall study, a major consideration is the fact that the city has very few easements along the drainageways thus compounding the difficulty in establishing the responsibility for alleviating any particular problem. Additionally, there are often problems with having adequate area to effectively and economically solve such problems.

The primary goals and objectives for the study are listed below:

- 1) Determine the location and nature (flooding, erosion, aesthetic or nuisance) of existing drainage-related (including erosion) problems throughout the city.

- 2) Establish a comprehensive and orderly means of systematically providing structural and nonstructural solutions to existing drainage and erosion problems.
- 3) Provide a means of eliminating or minimizing the number of drainage-related problems that will occur in the future by providing the appropriate policies and procedures (including a Drainage Criteria Manual) to effectively provide appropriate protection for areas experiencing growth in the future.
- 4) Develop a drainage-related maintenance system to allow for the proper tracking of maintenance needs and activities.
- 5) Establish a "priority" system to guide the order in which improvements are constructed to insure that other properties or persons are not damaged by the improvements. The priority system will be organized in a manner such that improvements made will not adversely impact others.
- 6) Develop an implementation plan that will assist the city in selecting appropriate procedures and actions to follow in carrying out the master plan recommendations as well as establish certain methods to fund the needed programs and prioritized improvements.
- 7) Establish a "Geographical Information System" (GIS) that will graphically locate and identify the various drainageways within the city as well as provide a linked data base that will have assorted information for each of the indentified drainage features. The GIS can be utilized to track maintenance activities as well as provide drainage feature location, type, size and other information.
- 8) Develop and provide hydrologic and hydraulic models that will describe the rainfall-runoff and flood level determination processes within the study area watersheds.

IDENTIFICATION OF DRAINAGE-RELATED PROBLEMS AND NEEDS

The identification and classification of drainage-related problems and needs provides the first step in developing a comprehensive master drainage study. The development of nonstructural and structural solutions is keyed to the location, nature and extent of the problems and needs identified. Identified problems and needs were basically classified in the following order of importance: 1) flooding (damage and safety), 2) erosion and 3) aesthetic/nuisance.

Regulatory Framework and Maintenance Requirements

In order to provide clarity in dealing with drainage-related issues, a consistent regulatory framework is required. To provide such a framework, present policies, procedures and ordinances were reviewed and evaluated. This review and evaluation led to the establishment of certain needs required to make the Master Drainage Plan functional. To satisfy these needs certain nonstructural solutions are proposed as plan recommendations. In most cases the regulatory recommendations made will apply city-wide and will be aimed at preventing future problems from being created rather than solving existing problems.

A review was also made of general city policies regarding maintenance of drainageways throughout the study area. This included evaluating the effectiveness of the ongoing herbicide program and assessing needs for expanding that program as well as upgrading other maintenance activities.

In general it was found that the city has a reasonably good regulatory framework from which to build. However, considerable changes and modifications to that framework must be done to make the developed master plan fully functional. A general listing of the needs identified is given below:

- 1) A plan, such as the proposed Master Drainage Plan, is needed to guide the overall drainage planning within the city's jurisdictional area.

- 2) There is a need for a Drainage Criteria Manual to provide guidance and consistency in analyzing and designing drainage systems within the city's jurisdictional control.
- 3) Erosion control procedures need to be incorporated into all subdivision and site development planning to prevent damage to facilities as well as the deposition of sediment in downstream drainage systems and waterbodies.
- 4) Ordinances should be modified to be clear and consistent between themselves and with the proposed Drainage Criteria Manual.
- 5) Maintenance activities need upgrading to assure the proper functioning of constructed drainage facilities. However, this need is dependent on the determination of the party (or parties) that is (are) responsible for an particular facility.

Erosion and Sedimentation

Erosion along numerous drainage systems (major and minor) and in upland areas, as well as the resulting sedimentation in downstream streams and lakes, constitute considerable problems in Longview. Erosion in certain areas threaten the foundation of structures and/or create an aesthetically undesirable situation. Reconnaissance trips, HEC-2 modeling and compliant reports document the existing problems associated with erosion and sedimentation along many of the major and minor drainage systems. For instance, erosion from construction in the local Loop 281 area appears to have caused serious sedimentation problems along Oakland Creek downstream of the Loop. Also, the Town Lake area has considerable sediment in it indicating erosion activity in the Guthrie Creek watershed.

It is obvious that situations such as these will worsen without controls in the newly developing areas and specific improvements to at least the worst existing problems areas. There is a strong need to establish erosion control for construction and post-construction periods. These controls are the best method to prohibit large-scale problems in watershed areas that have yet to experience significant development. For instance, future development in the Eastman Lake watershed has the potential to cause severe sedimentation problems in downstream areas, such as the Texas Eastman lakes, if sufficient controls are not established. As another example, future

uncontrolled erosion due to development in the upper Grace Creek watershed could significantly reduce the conveyance capability, as well as cause other problems along lower Grace Creek.

Drainage and Flooding Conditions

During the present study, the drainageways are classified and analyzed as "major" or "minor" when assessing drainage and flooding conditions depending if the contributed drainage area is greater or less than 100 acres, respectively. It is pointed out that the city is not presently assuming responsibility for any of the drainage systems and/or their associated problems. Unfortunately, only in recent years have drainage easements been systematically granted to the city in subdivisions that were being developed. The lack of drainage easements has caused a considerable dilemma concerning the responsibility for problems along these systems.

Drainage systems with less than a 100 acres of drainage area typically consist of small channels, roadside ditches, storm sewers, street curb and gutter sections or other similar systems. Information obtained from city files as well as numerous meetings with city staff and the project team's local consultants was used to assess the problems associated with the minor systems. The problems ranged in complexity and nature from structure flooding along small channels to nuisance erosion along roadside ditches. Beginning with information related to over 450 complaints made to the city, the problems were screened to determine those that deserved further evaluation. A general listing of the complaint calls/problem areas is being kept at the City Engineering Department.

Flooding conditions along the study area's major systems were evaluated by reviewing information related to the recent large storms that occurred in the Longview area, reviewing past FEMA studies as well as developing expected flood levels from hydrologic (HEC-1) and hydraulic (HEC-2) modeling. This modeling effort is a tremendous undertaking as there are over 75 square miles of watershed area and over 67 miles along major streams that required HEC-2 analysis.

Base hydrologic and hydraulic conditions for the study were determined from discussions with city staff, reviews of past studies, as well as hydrologic modeling of existing and projected watershed conditions utilizing the HEC-1 and HEC-2 computer programs. More

specifically, modeling of base conditions involved computing 10-, 50-,100- and 500-year flow conditions for the two studied conditions. However, primary emphasis has been placed on the analyzing the 100-year event. Existing conditions were studied to determine the potential flood hazard as it exists today. Future projected conditions were studied to assess the potential for increased flood potential following full development in the study area watersheds assuming that no flood control improvements would be built to protect existing developed areas.

For modeling and overall analysis purposes, the study area was divided into four overall basins including Grace Creek, Iron Bridge Creek, Eastman Lake Creek and Hawkins Creek. These major basins were further divided into contributing watersheds and/or watershed subareas of approximately 100 acres such that design flow rates could be generated with the HEC-1 model along the respective stream systems. Exhibit A in the report provides locations of the study area watershed/drainage network.

Results of the HEC-1 and HEC-2 modeling (provided under separate cover due to its large size) indicates that there are considerable flooding problems along almost every stream in the developed part of the city. Numerous houses and businesses are within the existing condition 100-year floodplain and even more are within the floodplain projected using the potential future watershed conditions. Practically every stream roadway crossing in the study area is overtopped by the two studied 100-year conditions thus indicating potential safety concerns along the roadway during such large flood events. Even though many new roadway crossings are being built to safely pass the 100-year flood, there are only a small fraction of stream roadway crossings throughout the state and country that avoid flooding during a 100-year flood event. In fact, the Texas Department of Highways and Public Transportation does not design all of its bridges and culverts to be flood free for a 100-year event.

Model Testing

The March 28-29, 1989 flood event that occurred in Longview was utilized to test our HEC-1 and HEC-2 modeling methods. Although rainfall amounts varied throughout the area, the

storm produced a rainfall total of approximately 6.7 inches in the downtown area from about noon on the 28th to 4 a.m. on the 29th.

The results are very supportive of the model predictability since the modeled elevations generally matched the observed high water marks within a foot. The level of agreement between the observed high water marks and modeled elevations is well within the expected degree of accuracy of the hydrologic techniques and models utilized.

ANALYSIS AND EVALUATION OF ALTERNATIVE SOLUTIONS

In order to determine the most feasible structural and non-structural solutions to utilize in resolving drainage problems, a screening process was applied to approximately 137 study reaches established throughout the study area. Generally, the solutions listed as means to decrease peak flows and stages tend to be structural in nature while the remaining items are mostly considered non-structural. The feasibility of utilizing a particular solution in a study reach was determined primarily on the potential ability of the alternative in alleviating or significantly reducing any existing or potential future flooding problems within the reach.

Utilizing input from City staff with screening procedures, the most feasible alternatives were selected for the study area. These final alternative solutions were determined to be channel and road crossing improvements, regional detention, acquisition and "no action". Following selection of the most feasible alternative solutions, a more detailed analysis of the selected alternatives was made with the goal of developing a recommended master plan of the study area, and improvements associated with selected alternative were evaluated. The structural alternatives were conceptually located, sized, hydrologically/hydraulically analyzed and costed. The nonstructural alternative evaluations were simply determining what is required to satisfy the needs associated with preventing future problems from occurring.

Channels, Roadway Crossing and Small Problem Areas

The many channel, roadway crossing and small area improvements were designed and prioritized according to the following guidelines (listed in order to their importance). Table 4-2 in the report presents the prioritization list.

- 1) no hydrologic impact - Improvements were sequenced to avoid impacts on others. This generally means improvements progress from downstream to upstream unless hydrologic "timing" of runoff allows another sequence.
- 2) effectiveness and safety - This relates to the degree that improvements solve flooding or other problem(s) within a design reach. Effectiveness is greater for those reaches with significant problems being resolved.
- 3) costs - Costs for all channel, roadway and small problem areas investigated totalled almost \$125 million.

Regional Stormwater Detention Facilities

An analysis was performed in the Grace Creek Watershed to assess the feasibility of stormwater detention to attenuate flood peaks throughout the watershed. The advantage of these sites is in the reduced channel improvement cost to convey the fully urbanized flows through the reach and the flood peak attenuation offsetting the flood peaks generated by upstream watershed urbanization and stream channel improvements.

Seven regional detention sites were initially considered as a solution to major creek flooding. Of these seven sites, four were shown to deserve further study along with expansion of the existing ponding area upstream of Loop 281. Evaluation of these five sites (upper Harris, upper Coushatta Hills, upper Oakland, Ray Creek and Grace Creek upstream of Loop 281) indicated that the Coushatta Hills, Harris Creek and Grace Creek/Loop 281 locations should receive serious consideration for inclusion in future Master Plan improvements. Cost for the Coushatta Hills, Harris Creek and Grace Creek/Loop 281 facilities were estimated at \$250,000, \$1,650,000 and \$5,000,000, respectively.

Acquisition

Although generally not a preferred solution to problem areas, acquisition of properties (e.g., houses) in the floodplain can sometimes be warranted due to the cost savings compared to other alternatives. However, it appears that approximately twelve (12) houses along lower Grace Creek (between Pecan Street and the Missouri Pacific Railroad), four (4) houses along Elm Creek (between Spur 502 and Miles Street) and two (2) houses along Peterson Court Creek may be candidates for acquisition. Very approximate costs to acquire these 18 properties were estimated at almost \$500,000.

No Action

There were numerous stream reaches studied that did not have a flooding problem. Most of these reaches were in undeveloped areas or in partially developed areas. The priority list presented in Table 4-2 of the report reflects these findings by moving these reach improvements down in the priority listing.

RECOMMENDED MASTER PLAN

A recommended Master Drainage Plan for the City of Longview has been formulated from the present study. It is anticipated that future review, coordination and discussions with City staff and the City Council will result in certain refinements of the recommended plan. Therefore, the recommended plan presented herein should be viewed as the basic framework from which to build an ultimate plan. Refinements of the recommended plan should be made following review of the basic study elements presented in this report with a awareness of the costs and responsibilities incurred as a result of the decisions made. The recommended master plan is presented in summary fashion here for ease in understanding and in anticipation of the future improvements that will be gained from the City and state review process. Basic components of the recommended plan are given below.

I. STRUCTURAL IMPROVEMENT OPTIONS

A. Channels, Roadway Crossings and Minor Drainage Systems Improvements

1. over 90 miles of major drainage systems designed
2. improvement costs for major systems exceed \$115 million but many of the improvements likely to be constructed by landowners or developers
3. hydraulically equivalent drainage systems (e.g., storm sewers) can be substituted for major channel system designs but cost estimates will remain basically unchanged
4. approximately 150 minor system conceptual designs developed
5. minor system costs totalled almost \$9 million
6. improvements costed and prioritized for major and minor drainage systems
 - a. priority list (Table 4-2) easily modified such that certain categories of problem classifications (e.g., nuisance problems in small areas) can be removed with the remaining elements remaining prioritized
 - b. priorities can be somewhat flexible as discussed in more detail in Section 4.0.
7. utilize developed Geographical Information System (G.I.S.) in locating and describing existing systems as well as proposed improvements
8. consider increased maintenance responsibilities for improved areas

B. Existing Creek System Cleaning

1. a front-end cleaning and minor channel grading improvement proposed as part of upgrading maintenance program
2. progress according to creek improvement priority listing in areas that are significantly clogged

C. Stormwater Detention Improvements

1. expand/redesign ponding area immediately upstream of Loop 281 along Grace Creek
 - a. costs of improvements estimated at \$5 million

2. upper Harris (upstream of Loop 281 in undeveloped area)
 - a. costs of improvements estimated at \$1.65 million
3. upper Coushatta Hills (upstream of Hwy 259)
 - a. costs of improvements estimated at \$0.25 million

II. NONSTRUCTURAL IMPROVEMENT OPTIONS

A. Acquisition

1. lower Grace (12 houses)
 - a. upstream of Sabine Street and downstream of U.S. Hwy 31
2. Elm Creek (4 houses)
 - a. downstream of Judson Road
3. Peterson Court Creek (2 houses)

B. Floodplain/Floodway Dedication

1. obtain park areas in preferred areas
2. maintain present procedure of obtaining drainage easement as areas are subdivided/platted although natural channels should be allowed in subdivision ordinance

C. Maintenance Planning

1. maintain existing herbicide program
 - a. monitor contractor performance and results
 - b. expand to include areas with vegetation problems
2. expand maintenance activities to master plan improvement areas
3. use G.I.S. system to track program

D. Regulatory Framework/Institutional Requirements

1. adopt Drainage Criteria Manual
 - a. institute standard design procedures
 - b. develop erosion control procedures

- c. require stormwater detention in certain areas depending on the status of downstream Master Plan channel and roadway crossing improvements
 - d. establish responsibility for future development runoff
 - 2. incorporate needed/proposed improvements into C.I.P. schedule

- E. Flood Warning
 - 1. upgrade emergency management system to incorporate flood forecasting
 - 2. develop rain and stream gage network to allow forecasting of flood events
 - a. recommend rain gages located near Elm Branch confluence with Ray Creek, Loop 281, Wildwood Lake Dam, near Coushatta Hills watershed and near upper Iron Bridge Creek Watershed
 - b. recommend flow gages located: Grace Creek at Loop 281 and Hwy 80; Oakland Creek below confluence with Coushatta Hills Creek and Guthrie Creek at Judson Road

- F. National Pollution Discharge Elimination System Planning (NPDES)
 - 1. plan for upcoming federal (Environmental Protection Agency - EPA) and state requirements
 - a. EPA regulations promulgated in October 1991 but does not affect the entire City of Longview's drainage system presently since population is below 100,000
 - b. the City should immediate determine its permit requirements covered under the "industrial activity" portion of the regulations including landfills (receiving industrial wastes), vehicle maintenance areas and the City's wastewater treatment plant
 - c. state pollution abatement program requirements likely promulgated in 1991 and will thereafter effect Longview unless proposed guidelines are changed
 - 2. future regulations may require:
 - a. stormwater program development

- b. identification of pollution (from runoff) sources
- c. estimation of pollutant discharge amounts
- d. location of illicit (i.e. illegal non-stormwater flows) connections
- e. control of construction site runoff
- f. ordinances to reduce pollutant discharges
- g. public education
- h. improved operation and maintenance programs
- i. funding from local sources

G. FEMA Update

- 1. study results should be utilized to update FEMA floodplains since most present information is outdated (1977 information)
- 2. submit updated floodplain information to FEMA for map revisions

III. IMPLEMENTATION OPTIONS

A. Determine Level/Extent of Structural Improvements to Undertake

- 1. assess costs and added responsibility (e.g. any future problems concerning drainage, erosion, etc. as well as increased maintenance requirements)
- 2. improvements to include all systems (major and minor), only major systems, no systems or some other level

B. Adopt Final Master Plan

- 1. obtain City staff and City Council input

C. Establish Funding Methods

- 1. options presented in Appendix E
- 2. methods selected following decisions on extent of improvements
- 3. NPDES considerations

D. Reassess Staffing to Match Added Work Loads

1.0 INTRODUCTION

In December 1989 Espey, Huston and Associates, Inc. (EH&A) entered into an agreement with the City of Longview to develop a Master Drainage Plan for the Longview vicinity. The Texas Water Development Board (TWDB) participated in the associated study by providing financial support and general guidance. The primary purpose of the study focused on developing a flexible and dynamic master plan that establishes the location and nature of existing and potential future drainage-related problems, evaluates various structural and nonstructural solutions to these problems and proposes a plan for prioritizing and implementing the needed improvements, institutional actions and regulatory adjustments to solve those problems. The plan's flexibility is of primary importance to allow for future conditions and considerations as well as to efficiently utilize available City financial resources.

In order to develop a project team with extensive local knowledge and experience, EH&A subcontracted with the local firms of Hart Engineering Company (assisted by Harle Engineering Company), KSA Engineers, Inc. and Walsh-Morris Engineering Company, Inc. to assist in the study. These firms provided valuable assistance in surveying, data gathering and interpretation, locating local drainage problems, reviewing local drainage-related policies and procedures, hydrologic studies, map digitizing as well as other efforts.

This Final Report documents our study methods and findings and establishes preparations of the Master Plan. Master Plan preparations have included numerous interactions and coordination with the City Staff, City Manager, City Council and TWDB.

1.1 STUDY AREA DESCRIPTION

The study area generally covers the approximately fifty (50) square miles within the City's corporate boundary and certain adjacent areas that drain into the City as shown in Figure 1-1. Being located in the northeast Texas timber belt within Gregg County, Longview is approximately 125 miles east of Dallas and 47 miles west of the Louisiana state border. The

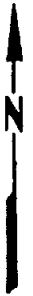
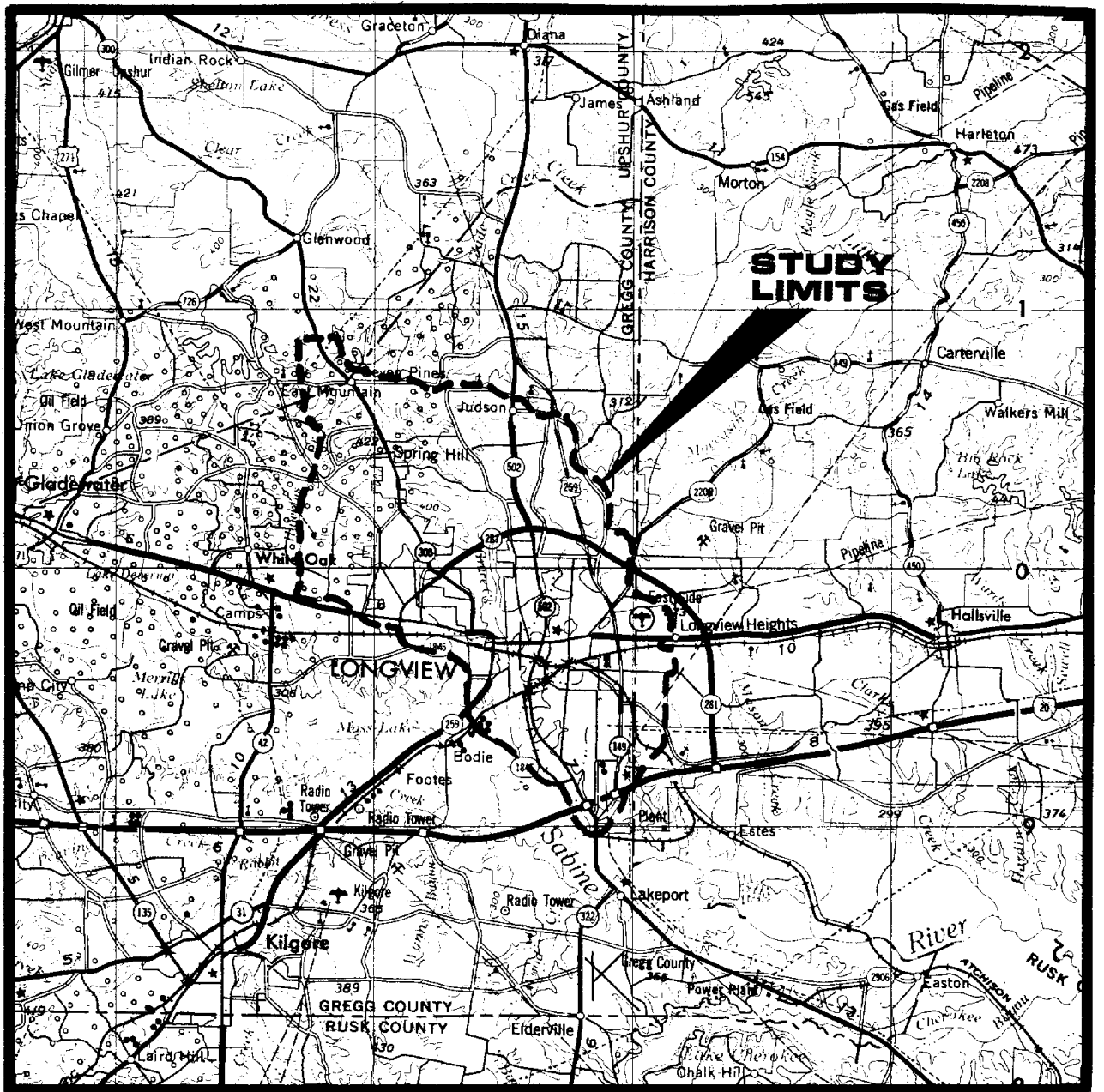

SCALE - 1:250,000

Source: USGS AMS SHEET
TYLER, TEXAS; LOUISIANA

eh ESPEY, HUSTON & ASSOCIATES, INC.
Engineering & Environmental Consultants

FIGURE I-1
VICINITY MAP

MASTER DRAINAGE PLAN—LONGVIEW, TEXAS

population of the county has been reported to be almost 110,000 in 1982 with Longview's present population near 70,000.

The local climate is temperate with temperatures ranging from near 0 to over 100 degrees Fahrenheit. The average annual precipitation is near 47 inches with the November to April period being the wettest period and the August to October being the driest (FEMA, 1990).

The surrounding topography is characterized by gently rolling hills with numerous streams draining to the Sabine River. Areawide soils were primarily formed under forest vegetation. Upland soils tend to be light colored loamy and/or sandy in nature. In unprotected areas, water erosion can easily occur. Floodplain soils along the Sabine and adjoining streams are generally loams or clays (USDA, 1983).

1.2 STUDY BACKGROUND

In the past flooding has occurred during localized thunderstorms but the worst flooding has been caused by frontal-type storms that generally occur during the spring and fall. The floods that occurred in April 1966 and March 1989 caused extensive damage in Longview with several casualties being reported as a result of the 1966 event. These storms have caused problems along the many "major" as well as "minor" drainageways within the City.

Flooding along the small or "minor" drainageways in the City contributes a large portion of the overall flooding problem as documented by the numerous complaint calls made to the City Staff. Following the March and May 1989 flood events that occurred in Longview, almost 75% of the calls made to the City were related to problems along these small drainageways.

Following the two floods in the spring of 1989, the City proposed the development of a master drainage study to develop a plan of action to combat the flooding problems. Although there are numerous important elements to the overall study, a major consideration is the fact that the City has very few easements along the drainageways thus compounding the difficulty in

establishing the responsibility for alleviating any particular problem. Additionally, there are often problems with having adequate area to effectively and economically solve such problems.

1.3 GOALS AND OBJECTIVES

The primary goals and objectives for the study are listed below.

- 1) Determine the location and nature (flooding, erosion, aesthetic or nuisance) of existing drainage-related (including erosion) problems throughout the City.
- 2) Establish a comprehensive and orderly means of systematically providing structural and nonstructural solutions to existing drainage and erosion problems.
- 3) Provide a means of eliminating or minimizing the number of drainage-related problems that will occur in the future by providing the appropriate policies and procedures (including a Drainage Criteria Manual) to effectively provide appropriate protection for areas experiencing growth in the future.
- 4) Develop a drainage-related maintenance system to allow for the proper tracking of maintenance needs and activities.
- 5) Establish a "priority" system to guide the order in which improvements are constructed to insure that other properties or persons are not damaged by the improvements. The priority system will be organized in a manner such that improvements made will not adversely impact others.
- 6) Develop an implementation plan that will assist the City in selecting appropriate procedures and actions to follow in carrying out the master

plan recommendations as well as present certain options to fund the needed programs and prioritized improvements.

- 7) Establish a "Geographical Information System" (GIS) that will graphically identify and locate the various drainageways within the City as well as provide a linked database that will have assorted information for each of the identified drainage features. The GIS can be utilized to track maintenance activities as well as provide drainage feature location, type, size and other information.
- 8) Develop and provide hydrologic and hydraulic models that will describe the rainfall-runoff and flood level determination processes within the study area watersheds.

1.4 GUIDE TO THE REPORT

This Final Report presents a descriptive overview of our study efforts and the results of those efforts. At the request of the City and to the extent practical, the report has been made graphical and tabular in nature to minimize the reading required to understand the contents. The study has included extensive analyses on a variety of issues that have led to the plan recommended herein.

The report has been structured to present the contents in an orderly fashion beginning with a general description of the study area and its problems (Sections 1 and 2), continuing with discussions of the analyses performed (Sections 3 and 4), followed by a description of the recommended plan (Section 5) and concluding with references (Section 6). Several appendices have been included to remove certain detailed technical discussions and information (e.g., tables, model input/output) from the main body of the report.

2.0 MASTER PLANNING OVERVIEW

Development of Longview's Master Drainage Plan considers the entire study area in such a way to include large as well as small areas. Considerations for future growth and plan flexibility have been a priority in the overall study. Plan development has been guided by the project goals and objectives stated in Section 1. The basic concept of master planning includes identification of the problem(s), development of solutions to the problem(s) and adoption of an overall implementation plan that organizes, prioritizes and provides funding options for the plan components. Another important aspect of master planning for Longview includes the development of a GIS capability to identify, describe and locate drainage features (as well as track related maintenance activities) throughout the City.

2.1 IDENTIFICATION OF PROBLEMS AND NEEDS

During the present study, identification of drainage-related problems and associated solutions focuses on watershed main-stem channels, watershed tributaries and small upland problem areas. Additionally, other "problems", "needs" and/or master planning considerations related to the City as a whole have also been considered. For instance, Longview presently has several ordinances, policies, criteria as well as creek maintenance practices concerning drainage and erosion control that required consideration and/or updating as part of the Master Plan process. The developed plan incorporates the structural improvements with the nonstructural elements (i.e. regulatory framework) to alleviate existing and potential future problems. Section 3 describes the investigations and analyses performed in identifying Longview's drainage-related problems and needs.

2.2 DEVELOP ALTERNATIVE SOLUTIONS

In order to arrive at the best solutions to the drainage problems in Longview, a systematic screening analysis was performed to focus on the most promising structural and nonstructural solutions. Results from the problem/needs identification efforts, potential solution effectiveness as well as pertinent constraints were considered to quickly dismiss many of the

potential solutions while pointing out promising ones. Constraints considered included the possibility of adverse impacts to others, safety, damage reduction and solution costs. Section 4 provides the procedures followed in developing and analyzing alternative solutions.

2.3 PLAN DEVELOPMENT

First, it is pointed out that the final Master Plan recommendations were formalized following appropriate review from, and coordination with, the City and TWDB. The recommended plan presented herein provides the basic structure from which to guide future drainage and flood control improvements within the City of Longview's jurisdictional area.

Establishment of the recommended plan began with consideration of the alternative plan components investigated. In developing solutions to existing and potential future problems, a combination of nonstructural and structural plan components were evaluated. Plan recommendations and improvement component prioritizations were developed by considering the effectiveness versus the constraints of each potential component. Channel and roadway improvements were prioritized according to the proper hydrologic sequencing (to insure that new problems are not created as a result of making the improvements), safety concerns (e.g., flood prone road crossings), their effectiveness in providing a solution and their costs.

Implementation of the plan is of foremost importance since it establishes "how to proceed." A major factor in the implementation process is funding. An overview of several funding options is provided in Appendix E to guide selection of the preferred method(s). In order to provide improvements associated with the Master Plan recommendations, a consensus on the most appropriate funding methods must be developed by the City. Once this consensus is developed and the funding method(s) are operational, improvement projects can be scheduled and constructed in accordance with the priorities established and available City financial resources.

3.0 IDENTIFICATION OF DRAINAGE-RELATED PROBLEMS AND NEEDS

As has been mentioned previously, the identification and classification of drainage-related problems and needs is the first step in developing a comprehensive master drainage study. The development of nonstructural and structural solutions is keyed to the location, nature and extent of the problems and needs identified. Identified problems and needs were basically classified in the following order of importance: 1) flooding (damage and safety), 2) erosion and 3) aesthetic/nuisance.

3.1 REGULATORY FRAMEWORK AND MAINTENANCE REQUIREMENTS

In order to provide clarity in dealing with drainage-related issues, a consistent regulatory framework is required. To provide such a framework, present policies, procedures and ordinances were reviewed and evaluated. This review and evaluation led to the establishment of certain needs required to make the Master Drainage Plan functional. To satisfy these needs certain nonstructural solutions are proposed as plan recommendations in Section 5. In most cases, the regulatory recommendations made will apply City-wide and will be aimed at preventing future problems from being created rather than solving existing problems.

A listing of the documents reviewed and evaluated is given below.

- 1) Ordinance Nos. 1882 and 1902 (Flood Hazard Management)
- 2) Ordinance No. 1066 (Subdivision Ordinance)
- 3) Ordinance No. 1870 (Dumping and Depositing Ordinance)
- 4) Policy Regarding Drainage Courses
- 5) Proposed Policy Regarding Roadside Ditch Maintenance
- 6) Draft #1 - An Ordinance Providing for the Control of Soil Erosion and Sedimentation from Areas Undergoing Development, and
- 7) A Contract Regarding the City's Herbicide Program

In general, it was found that the City has a reasonably good regulatory framework from which to build. However, considerable changes and modifications to that framework must be done to make the developed Master Plan fully functional.

A review was also made of general City policies regarding maintenance of drainageways throughout the study area.

Presently the City does not have a comprehensive maintenance program for the many drainageways throughout its jurisdictional area. Since the City has very few easements along these drainageways, the issue of maintenance responsibility is not well defined.

However, the City does have a herbicide program to control vegetation along certain rights-of-way and/or streams. This program is carried out by a contractor that generally sprays the herbicide twice annually. According to City staff, this program has proven to be successful in controlling trees (mostly willows), brush and large weeds in the targeted streams. Extreme care in application procedures and City monitoring are required to insure that the herbicide usage does not kill grass and other vegetation that protects the stream bed and side slopes from erosion without significantly reducing flow capacity. The City should maintain pre-qualification practices for contractors that bid on this work to insure that a selected contractor can perform the work in the appropriate manner.

Should the City decide to accept the maintenance responsibility of the many drainageways within its city limits or jurisdictional area, it would require a significant increase in manpower commitment and cost regardless if it used herbicide or mechanical procedures. The PC-ARC/INFO GIS system developed as part of this study has the capability to track maintenance activities on drainage structures throughout the City. The actual amount of the increased workload and cost would depend, of course, on the level of maintenance desired. In general, cities do not typically perform physical cleaning of every linear foot of a stream that is within its maintenance program on an annual basis. There is usually a rotation among the streams to be maintained and/or a cleaning on an "as needed" basis. Many times the "as needed" cleaning is balanced with

the available manpower and/or allocated budget to clean only those stream reaches needing it the most.

To give an example of the potential manpower and cost that would be associated with a totally comprehensive maintenance program in Longview, a projection was made using the present herbicide program which has a \$30,500 annual budget and is scheduled to cover 23 miles of stream per year. This establishes a \$1,326/mile ratio for projection purposes. Since the Master Plan channel improvements covered approximately 90 miles of stream (the total of all design reach lengths in Appendix B), 90 miles of stream length was multiplied by \$1,326/mile value established above to obtain an annual maintenance cost of \$119,340. If mechanical means were used to perform the cleaning, this value could be expected to at least double. Regardless of the procedures used, there would also be an access problem to numerous areas that would increase costs even more.

These projections of costs are given here to help put in perspective the very difficult question of whether or not to undertake such a maintenance program. On the other hand, the increase in flow conveyance would significantly reduce flood potential along the maintained drainageways. Also, less ambitious maintenance programs aimed at only the major drainageways would reduce program costs.

A general listing of the regulatory and maintenance needs identified is given below, with proposed solutions provided in Section 5.

- 1) A plan, such as the proposed Master Drainage Plan, is needed to guide the overall drainage planning within the City's jurisdictional area.
- 2) There is a need for a Drainage Criteria Manual to provide guidance and consistency in analyzing and designing drainage systems within the City's jurisdictional control.

- 3) Erosion control procedures need to be incorporated into all subdivision and site development planning to prevent damage to facilities as well as the deposition of sediment in downstream drainage systems and waterbodies.
- 4) Ordinances should be modified to be clear and consistent between themselves and with the proposed Drainage Criteria Manual.
- 5) Maintenance activities need upgrading to assure the proper functioning of existing and future constructed drainage facilities. However, this need is dependent on the determination of the party (or parties) that is (are) responsible for a particular facility.

3.2 EROSION AND SEDIMENTATION

Erosion along numerous drainage systems (major and minor) and in upland areas, as well as the resulting sedimentation in downstream streams and lakes, constitute considerable problems in Longview. Erosion in certain areas threaten the foundation of structures and/or create an aesthetically undesirable situation. The eroded soil material is transported downstream and deposited in areas where flow velocities allow material settling such as lakes, backwater areas and wide floodplain areas. This sedimentation process clogs drainage systems (including culverts, pipes and inlets), creates areas for willow tree growth, reduces lake storage volume and creates water quality problems. Erosion and sedimentation often occur in urban and urbanizing areas due to land disturbance as well as increased runoff rates, volumes and velocities associated with development. Flow constructions, such as overtaxed culverts, cause the eroded material to be deposited. This process causes the constriction to become worse.

Reconnaissance trips, HEC-2 modeling and compliant reports document the existing problems associated with erosion and sedimentation along many of the major and minor drainage systems. For instance, erosion from construction in the local Loop 281 area appears to have caused serious sedimentation problems along Oakland Creek downstream of the Loop. Also, the

Town Lake area has considerable sediment in it indicating erosion activity in the Guthrie Creek watershed.

It is obvious that situations such as these will worsen without controls in the newly developing areas and specific improvements to at least the worst existing problems areas. There is a strong need to establish erosion control for construction and post-construction periods. These controls are the best method to prohibit large-scale problems in watershed areas that have yet to experience significant development. For instance, future development in the Eastman Lake watershed has the potential to cause severe sedimentation problems in downstream areas, such as the Texas Eastman lakes, if sufficient controls are not established. As another example, future uncontrolled erosion due to development in the upper Grace Creek watershed could significantly reduce the conveyance capability, as well as cause other problems along lower Grace Creek.

3.3 DRAINAGE AND FLOODING CONDITIONS

As discussed briefly in Section 1, Longview is subjected to flooding due to local thunderstorms as well as storms associated with frontal passages in the spring and fall. These storms can have extremely intense rainfalls associated with them resulting in overtaxed drainage systems throughout the Longview area. The large storms that occurred in April 1966, March 1989 and May 1989 produced widespread flooding in the Longview area and are indicative of flood events that can occur. However, flooding in excess of what occurred during those storms is quite possible. Therefore, flooding that is even more devastating than those recorded events mentioned above can be expected to occur.

A large flood event that is often used as a guide in flood control planning efforts is referred to as the "100-year flood" since it is an event that can be expected to occur, on average, once in a 100-year period. However, it is possible that an area could experience two such events in consecutive years or even in the same year. A better definition or description of such an event is "an event that has a one percent chance of being equalled or exceeded in any given year." There are other ways to statistically view the likelihood of a 100-year (or larger) event occurring in any particular period of time. To give a few examples, there is a 10-percent chance, 22-percent chance,

40-percent chance or 63-percent chance that a 100-year (or larger) event will occur in any consecutive 10-year, 25-year, 50-year or 100-year time period, respectively. To further put the 100-year flood threat into perspective, a home located in a 100-year floodplain having a floor slab equal to the 100-year flood elevation would be expected to have a 26-percent chance of flooding during a 30-year home mortgage period. According to City staff, a home would only have a one-percent chance of suffering a fire loss during that same 30-year period.

According to City rainfall records, the March 1989 flood frequency was near a 25-year event along streams with relatively large contributing drainage areas such as lower Grace Creek. This is true since the storm produced a 12-hour rainfall total near seven inches (see Table A-1a in Appendix A). However, the same March 1989 storm did not produce any rainfall totals that exceeded a 5-year event for durations less than five hours. Therefore, smaller areas (such as Johnson Creek) that have drainage systems capable of responding to short, high-intensity rainfall amounts experienced less than a 5-year flood event. In fact, many of these small areas experienced less than a 1-year flood according to the recorded rainfall. Of course, any particular area may have received more or less rain than that recorded, and the resulting local flooding would have reflected those specific local rainfall conditions. In reviewing and assessing the flooding conditions in the study area, past occurrences, as well as conditions expected to occur as a result of a 100-year flood, were considerations.

During the present study, the drainageways are classified and analyzed as "major" or "minor" depending if the contributing drainage area is greater or less than 100 acres, respectively. It is pointed out that the City is not presently assuming responsibility for any of the drainage systems and/or their associated problems. Unfortunately, only in recent years have drainage easements been systematically granted to the City in subdivisions that were being developed. The lack of drainage easements has caused a considerable dilemma concerning the responsibility for problems along these systems.

3.3.1 Minor System Conditions

Drainage systems with less than 100 acres of drainage area typically consist of small channels, roadside ditches, storm sewers, street curb and gutter sections or other similar systems. Since there are too many of these small systems in the study area to allow individual analysis, only those systems or areas where problems have been reported to the City were considered. It has been assumed that a vast majority of the study area's problems have been identified and reported due to the sizable storms that have occurred in Longview in the recent past.

Information obtained from City files as well as numerous meetings with City staff and the project team's local consultants was used to assess the problems associated with the minor systems. The problems ranged in complexity and nature from structure flooding along a small channels to nuisance erosion along a roadside ditches. Beginning with information related to over 450 complaints made to the City, the problems were screened to determine those that deserved further evaluation.

A general listing of the complaint calls/problem areas is being kept at the City Engineering Department.

3.3.2 Major System Conditions

Flooding conditions along the study area's major systems were evaluated by reviewing information related to the recent major storms that occurred in the Longview area, reviewing past FEMA studies as well as developing expected flood levels from hydrologic (HEC-1) and hydraulic (HEC-2) modeling. This modeling effort is a tremendous undertaking as there are over 75 square miles of watershed area and over 90 miles of stream that required analysis. In order to accomplish this effort, the basic procedures listed below were followed.

- collect, review and assess all pertinent data including accounts of past flooding and past studies

- obtain and utilize the physiographic watershed and drainage system features
- utilizing the HEC-1 model, define the rainfall-runoff process for the 100-year event to obtain peak discharges along the studied waterways
- utilizing the HEC-2 model, define the flood water surface elevations along the studied waterways
- assess the nature and extent of flooding along the waterways based on past accounts of flooding (including past FEMA studies) and the modeled flood levels and the general number of structures (buildings and road crossings) flooded

3.3.2.1 Analysis of Base Hydrologic Conditions

Base hydrologic conditions for the study were determined from discussions with City staff, reviews of past studies, as well as hydrologic modeling of existing and projected watershed conditions utilizing the HEC-1 computer program. More specifically, modeling of base hydrologic conditions involved computing 10-, 50-, 100- and 500-year flow conditions for the two studied conditions. However, primary emphasis has been placed on analyzing the 100-year event.

Existing conditions were studied to determine the potential flood hazard as it exists today. Base future projected conditions were studied to assess the potential for increased flood potential following full development in the study area watersheds assuming that no flood control (i.e., Master Plan channel, roadway crossing or stormwater detention) improvements would be built to protect existing developed areas. Base future development conditions were assumed to be at minimum level of five single family residential units per acre (SF-4 zoning). If present land use is more intense than the minimum level, the higher level was used in all land use related computations. Consistent with anticipated Master Plan requirements, it was assumed that any land

use intensity associated with future development that exceeds the assumed five units per acre value would be adequately offset with the use of stormwater detention.

The SF-4 level of development was selected since it is the City's goal to accommodate runoff from residential areas with future Master Plan improvements. This goal is an attempt to allow residential development to proceed without undue hardship. However, it is also the City's goal to protect all property owners from being impacted by land use changes initiated by others. Therefore, the base future conditions flows developed are used to project future runoff conditions so that potential problems can be identified and the need for Master Plan improvements can be assessed. The Drainage Criteria Manual presents stormwater detention requirements for situations where there is protection provided by Master Plan improvements as well as situations where that protection is not yet available.

For modeling and overall analysis purposes, the study area was divided into four overall basins including Grace Creek, Iron Bridge Creek, Eastman Lake Creek and Hawkins Creek. These major basins were further divided into contributing watersheds and/or watershed subareas of approximately 100 acres such that design flow rates could be generated with the HEC-1 model along the respective stream systems. Exhibit A provides locations of the study area watershed/drainage network.

An extensive data collection effort was made to insure that subarea and watershed physiography could be accurately determined. Existing data such as land use information, topography, soils, aerial photographs and past studies such as conducted by the Federal Emergency Management Agency (FEMA, 1990) were obtained from the City and utilized to the extent possible. Field reconnaissance trips and engineering plans obtained from Hart Engineering Company were used to supplement the data gathering effort.

Figure 3-1 provides a general schematic of the Grace Creek, Iron Bridge Creek and Eastman Lake Creek watershed modeling effort while Figure 3-2 provides a similar schematic for the Hawkins Creek watershed. Table 3-1 presents peak discharges at various locations throughout the various watersheds keyed to the locations shown in Figures 3-1 and 3-2. As discussed

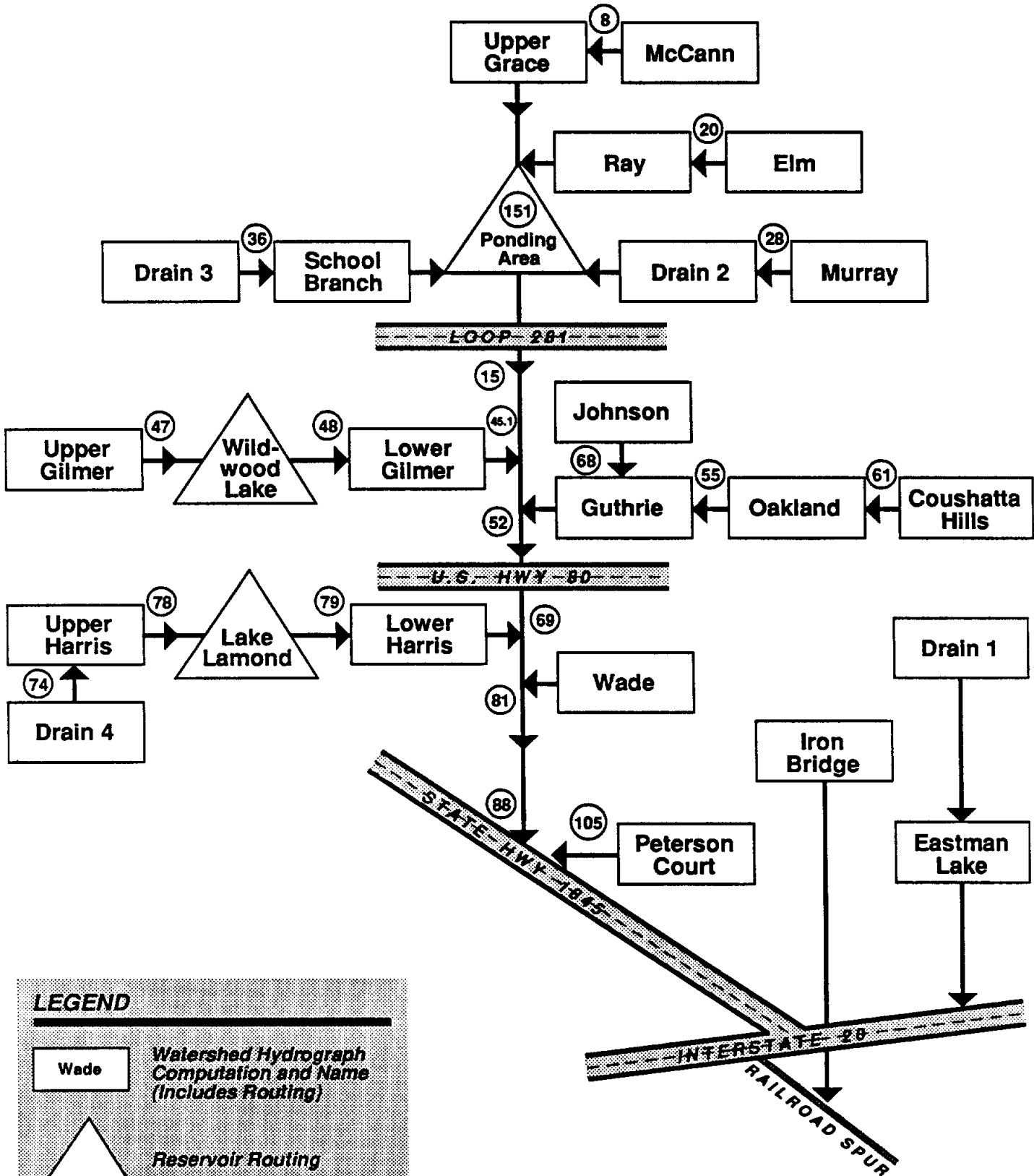

LEGEND





-  **Wade** Watershed Hydrograph Computation and Name (Includes Routing)
-  **Reservoir Routing**
-  **Hydrograph Combination Location**
-  **Stream Routing**

Figure 3-1
HYDROLOGIC SCHEMATIC
GRACE, IRON BRIDGE &
EASTMAN LAKE CREEKS
 Master Drainage Plan
 Longview, Texas



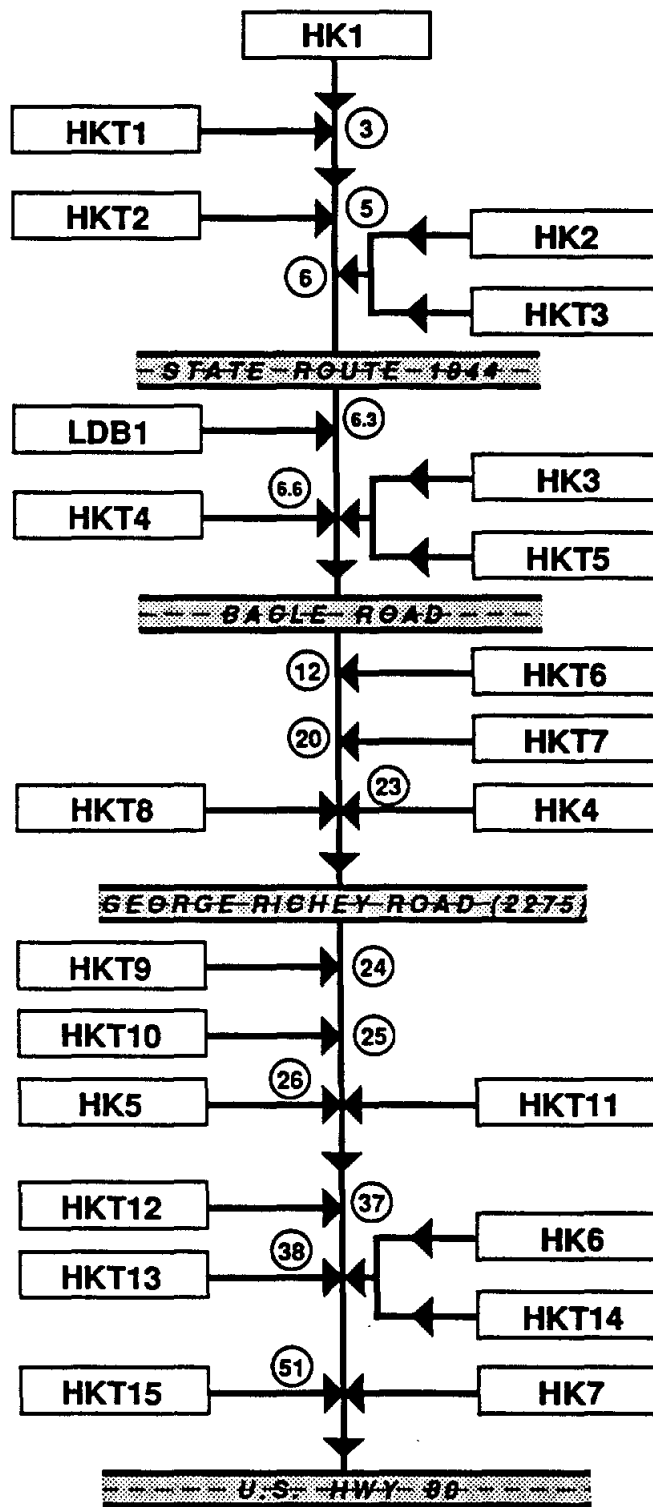

LEGEND	
	Watershed Hydrograph Computation & ID No. (Includes Routing)
	Hydrograph Combination Location
	Stream Routing

Figure 3-2
HYDROLOGIC SCHEMATIC
HAWKINS CREEK
 Master Drainage Plan
 Longview, Texas

TABLE 3-1
SUMMARY OF HEC-1 PEAK DISCHARGES

Location Nodes ¹	Existing Conditions (cfs)	Future Conditions ² (cfs)
Grace Creek		
8	5,107	7,538
20	4,721	6,027
36	4,027	4,823
28	3,932	5,305
151	17,313	23,436
15	15,013	22,053
47	1,340	1,642
48	1,145	1,404
45.1	16,772	23,900
68	6,847	7,904
55	6,126	6,936
61	4,129	4,723
52	16,672	23,832
74	1,866	2,092
78	6,842	8,764
79	6,654	7,941
69	23,840	33,629
81	23,532	33,516
88	24,324	34,402
104	1,979	2,014
Hawkins Creek		
3	1,919	2,767
5	2,508	3,514
6	4,593	6,183
6.6	7,419	10,294
12	7,436	11,341
20	1,159	1,712
23	10,473	13,190
24	10,634	13,423
26	10,886	13,787
26	10,873	13,828
37	12,429	15,935
38	12,564	17,814
51	13,411	18,465

TABLE 3-1 (Concluded)

Location Nodes ¹	Existing Conditions (cfs)	Future Conditions ² (cfs)
Eastman Lake Creek		
Below Confluence w/DR1	3,850	5,780
IH 20	7,930	11,250
Iron Bridge Creek		
IH 20	3,380	3,510
SFRR SPUR	4,940	5,230

¹ See Figures 3-1, 3-2 for location node information.

² These Future Condition flows reflect hydrologic conditions assuming Master Plan improvements are not made.

TABLE 3-2
STREAM REACHES INCLUDED IN HEC-2 MODELS

Stream	From	To	Stream Miles
<u>Eastman Lake Creek Watershed</u>			
Drain No. 1	mouth	Williams Rd.	3.4
Eastman Lake Creek	IH 20	Doyle St.	5.9
Lilly Creek	mouth	El Paso St.	1.0
<u>Grace Creek Watershed</u>			
Coushatta Hills Creek	confluence with Oakland Creek	1,095 ft upstream of Hollybrook Drive	1.3
Drain No. 2 (Oak Branch)	confluence with Grace Creek	100 ft downstream of Becky	3.6
Drain No. 3	confluence with School Branch	1,250 ft upstream of Hawkins Pkwy.	1.4
Drain No. 4	confluence with Harris Creek	200 ft upstream of Scenic Dr.	1.1
Elm Branch Creek	confluence with Ray Creek	2,500 ft upstream of Amy St.	1.6
Gilmer Creek	confluence with Grace Creek	Evergreen St.	2.1
Grace Creek	550 ft downstream of FM 1845	FM 1844	13.6
Guthrie Creek	confluence with Grace Creek	Wood Place	2.4
Harris Creek	confluence with Grace Creek	Dam and Spillway upstream corporate limits	4.8
Johnson Creek	confluence with Guthrie Creek	Loop 281	1.8
Murray Creek	confluence with Oak Branch	Sunnybrook Rd.	2.4
Oakland Creek	confluence with Guthrie	Dam and Spillway downstream of Tryon Rd.	3.4
Ray Creek	confluence with Grace	Upper McCann Rd.	4.8
School Creek	confluence with Grace	150 ft upstream of Bill Owens Pkwy.	1.7
Wade Creek	confluence with Grace	Foot Bridge in park upstream of Whaley St.	3.3
<u>Hawkins Creek Watershed</u>			
Hawkins Creek	900 ft upstream Richey Road	upstream of Swan St.	1.8
Lafamo Creek	confluence with Hawkins Creek	Baxley Lane	1.3
<u>Iron Bridge Watershed</u>			
Iron Bridge Creek	Santa Fe RR	Level St.	3.4
		TOTAL	66.7

subsequently in more detail, the peak discharges obtained from the HEC-1 analyses of these areas were then used with the HEC-2 program to obtain expected flood levels along the studied streams.

A detailed description of the HEC-1 modeling procedures is presented in Appendix A. Model input and output listings have been presented to the City under separate cover due to their large volume. Tables and a detailed Work Map (see map pocket at back of report) depict detailed physiographic and hydrologic computation information for the many watersheds and subareas throughout the study area.

3.3.2.2 Determination of Base Flood Elevations

Hydraulic analyses were conducted to provide estimates of base flooding levels along the streams which traverse the study area for existing and future projected conditions. The general approach used in these analyses was to refine and extend previous HEC-2 computer models developed by FEMA in past studies. The FEMA models were originally developed for the Flood Insurance Study of the City of Longview which was published in December 1977 (FEMA, 1977). The Flood Insurance Study was revised and updated by FEMA in June 1986 (FEMA, 1986) and again in January 1990 (FEMA, 1990) to include areas annexed into the City of Longview since the original 1977 study. Additionally, FEMA published the Flood Insurance Study of Gregg County (Unincorporated Areas) in January 1990, portions of which have been included herein. The FEMA models were updated to include changes which have occurred since 1977 such as construction of improved channels and bridges, development which altered floodplain elevations as well as other floodplain modifications. The models were extended to include areas upstream and downstream of past FEMA studies. Table 3-2 presents stream reaches which were studied as part of this study.

The HEC-2 program requires a mathematical description of the stream channel and floodplain which is primarily provided by: 1) cross sections at regular intervals and at locations of major obstructions such as bridges, dams, and other structures occupying the floodplain, 2) distances between cross sections, and 3) estimates of roughness values of stream channels and overbanks. Numerous cross sections were field surveyed and added to the FEMA HEC-2 stream

TABLE 3-2
STREAM REACHES INCLUDED IN HEC-2 MODELS

Stream	From	To	Stream Miles
<u>Eastman Lake Creek Watershed</u>			
Drain No. 1	mouth	Williams Rd.	3.4
Eastman Lake Creek	IH 20	Doyle St.	5.9
Lilly Creek	mouth	El Paso St.	1.0
<u>Grace Creek Watershed</u>			
Coushatta Hills Creek	confluence with Oakland Creek	1,095 ft upstream of Hollybrook Drive	1.3
Drain No. 2 (Oak Branch)	confluence with Grace Creek	100 ft downstream of Becky	3.6
Drain No. 3	confluence with School Branch	1,250 ft upstream of Hawkins Pkwy.	1.4
Drain No. 4	confluence with Harris Creek	200 ft upstream of Scenic Dr.	1.1
Elm Branch Creek	confluence with Ray Creek	2,500 ft upstream of Amy St.	1.6
Gilmer Creek	confluence with Grace Creek	Evergreen St.	2.1
Grace Creek	550 ft downstream of FM 1845	FM 1844	13.6
Guthrie Creek	confluence with Grace Creek	Wood Place	2.4
Harris Creek	confluence with Grace Creek	Dam and Spillway upstream corporate limits	4.8
Johnson Creek	confluence with Guthrie Creek	Loop 281	1.8
Murray Creek	confluence with Oak Branch	Sunnybrook Rd.	2.4
Oakland Creek	confluence with Guthrie	Dam and Spillway downstream of Tryon Rd.	3.4
Ray Creek	confluence with Grace	Upper McCann Rd.	4.8
School Creek	confluence with Grace	150 ft upstream of Bill Owens Pkwy.	1.7
Wade Creek	confluence with Grace	Foot Bridge in park upstream of Whaley St.	3.3
<u>Hawkins Creek Watershed</u>			
Hawkins Creek	900 ft upstream Richey Road	upstream of Swan St.	1.8
Lafamo Creek	confluence with Hawkins Creek	Baxley Lane	1.3
<u>Iron Bridge Watershed</u>			
Iron Bridge Creek	Santa Fe RR	Level St.	3.4
		TOTAL	66.7

models. Field notes from the surveying required to obtain these sections have been furnished to the City. Additional cross sections were obtained from plans for bridge improvements undertaken since the 1977 FEMA study furnished by the City and the project team's local consultants and from bridge plans obtained from the Texas State Department of Highways and Public Transportation as shown in Table 3-3. Where considered necessary for definition of flood profiles, additional cross sections were developed using City topographic maps with contour interval of 5 feet and scale of 1:2400 (1 inch = 200 feet). Distances between cross sections were scaled from the City topographic maps.

FEMA reference marks (1929 NGVD) were used for vertical control to insure compatibility with FEMA models. Where in close proximity to field surveys, City bench marks were tied in and generally found to be within 1.0 feet of FEMA elevations.

Roughness values of stream channels and overbanks were estimated by engineering judgement based on field observations, aerial photography, and prior estimates in FEMA studies. Channel roughness values generally varied from approximately 0.015 to over 0.1. Overbank roughness values varied from approximately 0.02 to 0.15.

The hydraulic studies presented herein were based on unobstructed flow at all roadway crossing or other structures. The flood elevations are applicable only if structures remain unobstructed and do not fail during flood events.

Computation of Discharge-Storage Data for HEC-1 Models

The HEC-2 models developed herein were used to compute discharge-storage data which was input into HEC-1 models for storage routing of flood hydrographs using the Modified Puls technique. Using a range of flood flows, flood profiles were computed using the HEC-2 models. Floodplain storage in acre-feet was computed between pertinent cross sections for respective flows analyzed and extracted for use in HEC-1 models. Additional discussion of this routing technique can be found in Appendix A.

TABLE 3-3

FEMA HEC-2 MODEL UPDATES FOR MASTER DRAINAGE STUDY

Creek	Location	FEMA Channel or Structure Size	Present Channel or Structure Size
Grace	Above FM 1845	Not in model	Fill associated with Birdsong Street
	Sabine Street	Bridge	Bridge and seven 10'x7' boxes (Relief Bridge)
	Hwy 80 to Fairmont Road	Not in model	Fill in right overbank associated with Bill Owens Parkway
	Fairmont Road	5-10'x10' boxes	Bridge
	H.G. Mosley	Not in model	Bridge
	Hawkins Parkway	Not in model	Future eight 10'x10' boxes
	Hawkins Parkway to Gregg County Study	Not in model	Cross sections from topographic map
	Spring Hill Road	Not in model	Five 10'x10' boxes
	Graystone Road	Not in model	Two-84" steel pipes and one-78" steel pipe
	2000' upstream of Graystone Road into Gregg County	Not in original FEMA	Added cross sections from Gregg County Study
Wade	Garfield Road	Bridge	Two-24'x10' crown spans
	King Street	Not in model	Three-10'x5' boxes

TABLE 3-3 (Cont'd)

Creek	Location	FEMA Channel or Structure Size	Present Channel or Structure Size
Harris	H.G. Mosley Blvd.	Not in model	Five-10'x9' boxes
	Lynnwood Drive	39" x 60" CMP Arch	Two 42" RCPs
	Lynnwood Drive to pond upstream of Swan St.	Not in model	Cross sections surveyed or taken from topographic map
	Swan St.	Not in model	Two-60" RCPs
Drain #4	Scenic Street to 750 ft downstream	Not in model	Concrete channel
Guthrie	Judson Road	Four-10'x10' boxes	Five-10'x8' boxes
	Triple Creek Center	Not in model	Channelization and fill
Johnson	Triple Creek Center	Not in model	Channelization and fill
	Triple Creek Drive	Not in model	10'x8' box
	Private Drive to Triple Creek Center	Not in model	10'x8' box

TABLE 3-3 (Cont'd)

Creek	Location	FEMA Channel or Structure Size	Present Channel or Structure Size
Oakland	Triple Creek Center	Not in model	Channelization and fill
	Hollybrook Drive	Bridge	Four-8'x8' boxes
	Fourth Street	Not in model	Three-10'x7' boxes
	Loop 281 to Hwy 259	Not in model	Extended model with cross sections from topographic map
	Hinsley Park	Not in model	Fill and various RCPs under baseball field and park road
	Hwy 259 into Gregg County	Not in original FEMA model	Added Gregg County Study
Gilmer	H.G. Mosley	Lake spillway structure	Two 10'x10' boxes with concrete spillway downstream
	Meandering Way	Not in model	Two-10'x10' boxes
	Evergreen	Not in model	60" RCP
Oak Branch-Drain No. 2	McCann Road to 1600 ft upstream of Hill Street	Not in model	Extended model with cross sections from survey and topographic maps
	Hawkins Parkway	Not in model	Four-10'x8' boxes and channel

TABLE 3-3 (Cont'd)

Creek	Location	FEMA Channel or Structure Size	Present Channel or Structure Size
Oak Branch-Drain No. 2 (Concluded)	Judson Road	Not in model	Two-10'x10' boxes
	Hill Street	Not in model	Two-72" steel pipes
	1600 ft upstream of Hill Street into Gregg County	Not in original FEMA study	Added Gregg County Study
Murray	Confluence with Oak Branch-Drain #2 to 1500 feet upstream of Airline Road	Not in model	Extended model with cross sections from topographic maps
	Airline Road	Not in model	Two 72" CMPs
	1500 feet upstream of Airline road into Gregg County	Not in original FEMA model	Added Gregg County Study
School Branch	Hawkins Parkway	Not in model	Three 10'x8' boxes
	1000 ft downstream of Hawkins Parkway to Bill Owens Parkway	Not in model	Extended model with cross sections from survey and topographic maps
	Bill Owens Parkway	Not in model	Three-8'x8' boxes
Drain No. 3	Bill Owens Parkway	Not in model	Two-10'x10' boxes
	Hawkins Parkway 2400 ft downstream of Hawkins Parkway to just below Gilmer Road (Hwy 300)	Not in model	Three-6'x6' boxes
Ray	Pliler Road	Two-72" CMPs	Two-72" RCPs

TABLE 3-3 (Cont'd)

Creek	Location	FEMA Channel or Structure Size	Present Channel or Structure Size
Elm Branch	Plier Road	One-96" CMP	Two-60" RCPs
McCann	Confluence with Grace Creek to 1100 ft upstream of Greystone Road	Not in model	Extended model with cross sections from topographic maps
	Greystone Road	Not in model	One-60" RCP
	1100 ft upstream of Greystone Road into Gregg County	Not in original FEMA model	Added Gregg County Study
Lafamo	Confluence with Hawkins to Lafamo Road	Not in model	Added oil field roads, surveyed cross sections and sections from topographic maps
Eastman Lake	IH 20 to Cotton St.	Not in model	Extended model w/surveyed cross sections and sections from topographic maps
Drain No. 1	US 80 to North of Alpine St.	Not in model	Extended model w/surveyed cross sections and sections from topographic maps
Lilly (Eastman Creek trib.)	Mouth to El Paso	Not in model	Extended model with surveyed cross sections
Iron Bridge	SFRR to IH 20	Not in model	Extended model w/surveyed cross sections and sections from topographic maps
	Holiday Inn	Not in model	Fill associated with Holiday Inn development

TABLE 3-3 (Concluded)

Creek	Location	FEMA Channel or Structure Size	Present Channel or Structure Size
Iron Bridge (Concluded)	Margo Street	5-60" RCPs	Crown span of 36' span x 10' H
	Millie Street	Not in model	3-10'x10' box culverts
	Wells St.	4-60" RCPs	3-10'x6' box culverts

Computation of Flood Profiles

Existing and future projected condition flood profiles were computed for stream reaches identified in Table 3-2 using HEC-2 stream models and peak flood flows computed by associated watershed HEC-1 models. For the two watershed conditions, flood flows were computed for 10-, 50-, 100- and 500-year floods. These flood flows were input to HEC-2 models for computation of flood profiles.

In instances where estimated 100-year peak discharges did not change appreciably, computed flood elevations for existing conditions are generally consistent with FEMA flood profiles except in stream reaches in which channel and bridge improvements have been constructed since FEMA flood profiles were computed and in areas experiencing excessive channel vegetation and/or encroachments. The updated flood profiles are lower than the FEMA flood profiles in the areas with recent channel and bridge improvements and higher in areas with elevated channel vegetation, encroachments and other obstructions to flow. In the few areas where peak discharges were computed to be significantly different than past FEMA analyses, the flood levels changed accordingly. This information can be submitted to FEMA with a Letter of Map Amendment (LOMA) requesting amendment of FEMA flood data if the updated flood data warrants such revisions. Based on the existing conditions flood profiles, the March 28-29, 1989 flood (discussed subsequently) appears to be no greater than approximately a 10-year flood in most areas although the event size varied throughout the study area.

As indicated by the modeling performed, the increase in flood levels from existing watershed development to fully developed watersheds varies considerably between watersheds. In the Eastman Lake Creek watershed, which is one of the lesser developed watersheds, a 1 to 2 feet rise is computed in most stream reaches with 1 foot being close to the average differential. In the reach of Eastman Lake Creek above U.S. Highway 80, which is almost fully developed, the increase is generally less than 0.5 feet and indistinguishable in some reaches. This is also the case in the Iron Bridge Creek watershed, which is essentially fully developed, where the differential flood levels are generally less than 0.5 feet.

Results of the HEC-2 modeling (provided under separate cover due to its larger size) indicates that there are considerable flooding problems along almost every stream in the developed part of the City. Numerous houses and businesses are within the existing condition 100-year floodplain and even more are within the floodplain projected using the potential future watershed conditions. Practically every bridge in the study area is overtopped by the two studied conditions thus indicating potential safety concerns along the roadway during such large flood events.

3.4 TEST OF MODELING TECHNIQUES USING HIGH WATER MARKS FROM THE MARCH 28-29, 1989 FLOOD EVENT

The March 28-29, 1989 flood event that occurred in Longview represents an recent extreme event which provides the opportunity to test our HEC-1 and HEC-2 modeling methods. Although rainfall amounts varied throughout the area, the storm produced a rainfall total of approximately 6.7 inches in the downtown area from about noon on the 28th to 4 a.m. on the 29th. To test our modeling effort, the referenced storm event rainfall was input into HEC-1 models of the Guthrie, Johnson, Oakland, Wade and Iron Bridge Creek watersheds to obtain peak flow rates therein for the storm. These watersheds were selected for analysis since they are located in the vicinity of the storm's recorded time distribution of rainfall. Rainfall amounts during the storm were obtained directly from rain gage charts provided by the City and are given in Table 3-4. The gage is located at City Hall on Cotton Street just east of Spur 63.

The peak flow rates obtained from the watershed HEC-1 models were then input into HEC-2 models for the respective watershed creeks to obtain flood elevations in the same areas where high water marks (HWM's) or elevations had been located and documented by the City following the storm. Table 3-5 presents the flow rates predicted by the watershed HEC-1 models as well as the associated HEC-2 elevations and high water mark elevations. The results are very supportive of the model predictability since the modeled elevations generally matched the observed high water marks within a foot. The level of agreement between the observed high water marks and modeled elevations is well within the expected degree of accuracy of the hydrologic techniques and models utilized.

TABLE 3-4
STORM RAINFALL ANALYSIS

28-29 March 1989 Storm

Time	Incremental Rainfall (IN)	Cumulative Rainfall (IN)	Running Totals		
			30 MIN	1 HR	2 HR
28 Mar '89 3:00(pm)	0.00	0.00			
3:15	0.12	0.12			
3:30	0.07	0.19	0.19		
3:45	0.10	0.29	0.29		
4:00	0.10	0.39	0.27	0.39	
4:15	0.05	0.44	0.25	0.44	
4:30	0.06	0.50	0.21	0.38	
4:45	0.29	0.79	0.40	0.60	
5:00	0.24	1.03	0.59	0.74	1.03
<u>5:15</u>	0.76	1.79	<u>1.29</u>	1.40	1.79
5:30	0.10	1.89	1.10	1.45	1.77
5:45	0.15	2.04	1.01	1.54	1.85
6:00	0.10	2.14	0.35	1.35	1.85
6:15	0.15	2.29	0.40	1.26	1.90
6:30	0.10	2.39	0.35	0.60	1.70
6:45	0.05	2.44	0.30	0.55	1.94
7:00	0.20	2.64	0.35	0.60	1.85
7:15	0.05	2.69	0.30	0.55	1.66
7:30	0.20	2.89	0.45	0.60	1.10
7:45	0.43	3.32	0.68	0.93	1.68
8:00	0.17	3.49	0.60	1.05	1.45
8:15	0.68	4.17	1.28	1.53	2.03
<u>8:30</u>	0.18	4.35	1.03	<u>1.66</u>	<u>2.06</u>
8:45	0.04	4.39	0.90	1.50	2.00
9:00	0.05	4.44	0.27	1.12	1.80
9:15	0.05	4.49	0.14	1.00	1.85
9:30	0.09	4.58	0.19	0.41	1.89
9:45	0.06	4.64	0.20	0.29	1.75
10:00	0.11	4.75	0.26	0.36	1.43
10:15	0.09	4.84	0.26	0.40	1.35
10:30	0.05	4.89	0.25	0.40	0.72
10:45	0.05	4.94	0.19	0.36	0.59
11:00	0.02	4.96	0.12	0.32	0.57
11:15	0.00	4.96	0.07	0.21	0.52
11:30	0.02	4.98	0.04	0.14	0.49
11:45	0.11	5.09	0.13	0.20	0.51
29 Mar '89 12:00(MID)	0.17	5.26	0.30	0.32	0.62
12:15(am)	0.08	5.34	0.36	0.38	0.59
12:30	0.05	5.39	0.30	0.43	0.55
12:45	0.06	5.45	0.19	0.47	0.56

TABLE 3-4 (Concluded)

Time	Incremental Rainfall (IN)	Cumulative Rainfall	Running Totals		
			30 MIN	1 HR	2 HR
1:00	0.12	5.57	0.23	0.48	0.63
1:15	0.26	5.83	0.44	0.57	0.87
1:30	0.40	6.23	0.78	0.89	1.27
1:45	0.24	6.47	0.90	1.08	1.49
2:00	0.08	6.55	0.72	1.10	1.46
2:15	0.03	6.58	0.35	0.77	1.32
2:30	0.01	6.59	0.12	0.76	1.25
2:45	0.02	6.61	0.06	0.38	1.22
3:00	0.04	6.65	0.07	0.13	1.20
3:15	0.08	6.73	0.14	0.18	1.16
3:30	0.04	6.77	0.14	0.19	0.94
3:45	0.04	6.81	0.16	0.22	0.58
4:00	0.00	6.81	0.08	0.20	0.34
MAX. DEPTH (IN)	0.76	---	1.29	1.66	2.06
MAX. INTENSITY (IN/HR)	3.04	---	2.58	1.66	1.03

TABLE 3-5
 HEC-1/HEC-2 MODEL VERIFICATION
 USING 28-29 MARCH 1989 FLOOD
 HIGH WATER MARKS

Location	Observed HWM Elevations (ft)	Model (HEC-2) Elevations (ft)	Model (HEC-1) Peak Discharges (cfs)
<u>Iron Bridge Creek</u>			
Millie Street (D.S.) ¹	292.2	293.1 (+0.9)	1,050
Raney Drive (U.S.) ²	308.4	308.6 (+0.2')	720
Birdsong Street (U.S.)	315.7	314.5 (-1.2')	570
<u>Wade Creek</u>			
Garfield Drive (U.S.)	263.4	264.1 (+0.7')	2,200
<u>Guthrie Creek</u>			
Glencrest Lane (U.S.)	283.8	286.4 (+2.6') ³	4,520
Judson Road (U.S.)	296.9	296.1 (-0.8')	3,790
<u>Johnson Creek</u>			
Triple Creek Drive (D.S.)	299.2	297.6 (-1.6')	790
<u>Oakland Creek</u>			
Hoyt Drive (D.S.)	303.8	303.3/307.2 (+1.5') ⁴	2,050
Eden Drive (U.S.)	309.8	309.5 (-0.3')	2,050
Hollybrook Drive (U.S.)	328.8	327.1 (-1.7')	1,500
Fourth Street (U.S.)	340.4	336.2 (-4.2') ⁵	1,500

- Notes:
- 1 - D.S. = Downstream
 - 2 - U.S. = Upstream
 - 3 - Roughness factor in channel may be lower than 0.04 used.
 - 4 - Model shows critical depth occurs downstream of bridge so water surface profile unstable. Elev. 307.2 immediately downstream of bridge and elev. 303.3 a short distance downstream.
 - 5 - Sediment in channel likely cause of high observed HWM elevation.

4.0 ANALYSIS OF ALTERNATIVE SOLUTIONS

As detailed in Section 3.0, problems and needs were identified for the City's regulatory framework related to drainage, maintenance, erosion and sedimentation as well as drainage and flooding conditions. Since needed solutions to the regulatory framework, maintenance program and certain erosion/sedimentation problems do not require a rigorous alternative analysis, they will be presented in the Master Plan recommendations in Section 5. The remainder of this section will focus on alternative solutions to drainage and flooding as well as stream erosion problems.

Stormwater programs and flood control/drainage solutions used in other cities provided useful insight to possible solutions in Longview. Experience in performing similar studies for other cities (especially in Texas) also assisted in developing solutions for Longview. Information obtained from two 1982 North Central Texas Council of Governments studies (see Section 6.0) provided considerable information for the north central Texas area.

The overall analysis of alternative solutions for the drainage and flooding problems and needs identified basically involves dividing the study area into study reaches, establishing evaluation factors, screening (selecting) possible alternative solutions and evaluating those alternatives selected. The components of our overall analysis are presented below.

4.1 DELINEATION OF STUDY REACHES

A useful and proven technique in locating, organizing and assessing flooding conditions within a watershed as well as developing alternative solutions to alleviate such flooding conditions involves subdividing the study area drainage systems into individual study reaches. In this manner, problems as well as opportunities for appropriate solutions can be more effectively developed, understood and dealt with. This technique was utilized in studying flooding conditions (especially those associated with existing problems) in Longview and developing portions of the master drainage plan. Additional portions of the master plan consist of an overlay of regulatory requirements to assist in handling drainage-related issues, especially in areas developed in the future.

Based on the distribution of land use, physiography, hydrology, and floodplain hydraulics, study reaches were delineated within the floodplain areas of concern within the Grace, Iron Bridge, Eastman Lake, Peterson Court and Hawkins Creek watersheds. Where there was a significant change in land use type, a confluence between two or more significant drainageways or where a physical impediment (natural surface topography, bridge, highway, etc.) was present, consideration was given to identifying a separate study reach. Utilizing this procedure, the flooding conditions and/or flood damage potential were made to be roughly similar within a reach. As a result of this process, a total of approximately 137 separate study reaches were delineated in the five watersheds, as shown in Figure 4-1. Abbreviated watershed designations are provided in Figure 4-1 as well as Figures 4-3 and 4-4 presented subsequently. The reach designations and assessments of existing and potential future flooding problems provide the organizational framework needed to develop and evaluate master plan alternative improvements.

4.2 EVALUATION FACTORS

In order for judgements or decisions to be made in the screening and selection of the most feasible alternatives, a few basic evaluation factors must be considered. These factors can be generally applied in the consideration of all possible alternative solutions, while formulating and selecting the (approximately) three most feasible alternatives. These factors can then be utilized more specifically, and in greater detail, in the evaluation of those most feasible alternatives.

The primary factor is, of course, the ability of a particular alternative to reduce, prevent and/or control flooding and erosion within a reach or several reaches. Consideration of this in the study required at least a general knowledge of the location, extent and nature of the existing and (potential) future drainage-related problems. This information has been developed as presented in Section 3 and primarily focuses on the number of houses, buildings and/or bridges/culverts flooded along the study area reaches as discussed previously.

Another evaluation factor concerns the effect (positive or adverse), if any, that a particular alternative solution would have on upstream and/or downstream reaches concerning flooding, erosion/sedimentation, water quality and park planning. For instance, channel

improvements may reduce flood stages in upper watershed reaches but could potentially increase peak flows downstream and, potentially, negatively impact downstream flooding and/or erosion problems. As another example, a detention facility in the lower portion of a watershed might delay local runoff, causing it to combine with the highest flows from the upper watershed, and thus negatively impact downstream areas.

An important factor also involves the practicality and/or cost of utilizing a particular alternative in an area or reach. In many instances, it may be fairly obvious that a particular type of flood control method seems impractical or ineffective from a cost standpoint. An example would be a fully-developed tributary area in which the upper portions are densely developed on land with a high value. It would generally be difficult to justify building an adequately sized stormwater detention facility in such an area, thus rendering that type of flood control methodology impractical.

4.3 SCREENING (SELECTING) POTENTIAL ALTERNATIVE SOLUTIONS

There are numerous actions that can be taken and/or structural improvements that can be built to solve, reduce or prevent drainage-related problems. For the present study, these alternative solutions have been grouped into structural and non-structural categories as shown in Table 4-1. Although not intended to be all-inclusive, a general description of possible alternatives is given below. Engineering textbooks and manuals can be consulted for additional definitive information on the methodologies.

1. Onsite Detention/Retention--This (or these) method(s) respectively refer to detaining or retaining stormwater on individual development sites (e.g., residential subdivisions, apartments, retail centers, industrial areas) for the purpose of reducing the site's runoff rates and, therefore, runoff rates in downstream areas. Detention is short-term stormwater storage with the facility area being depleted by one or more flow outlets. Retention stormwater storage is held for a long period of time and is generally depleted by evaporation. It is possible to design a facility that has both detention and retention features,

TABLE 4-1

ALTERNATIVE SOLUTIONS TO DRAINAGE PROBLEMS

Alternative Solutions	Means of Protection
<u>STRUCTURAL</u>	
Onsite Detention/Retention	Decrease Peak Flows
Offsite or Regional Detention/Retention	
Floodplain Storage Preservation	
Flow Diversion	
Channel Improvements	Decrease Peak Stage for Given Flow
Removal/Modification of Flow Constrictions	
Levees/Dikes	
<u>NONSTRUCTURAL</u>	
Mechanical Floodproofing of Existing Structures	Keep Water Out of Structures
Mechanical Floodproofing of New Structures	
Elevate Foundations of Existing Structures	
Elevate Foundations of New Structures	
Relocation/Acquisition of Structures	Keep Structures Away from Water
Subdivision and/or Zoning Regulations	
Public Acquisition of Open Space	
Flood Early Warning System/Evacuation Plan	Decrease Damages Under Existing Conditions
Flood Insurance	
No Action	

such that part of the stormwater inflow is detained and part retained in the facility as a water amenity or water quality enhancement measure. There are many design aspects that require careful consideration in order to ensure that a detention or retention facility functions properly and is safe. These items include design flood magnitude and frequency, overflow spillway structure(s), safety features, dam construction, legal issues, operation and maintenance, health and nuisance concerns, as well as aesthetics. As is done in many stormwater management planning efforts, the present plan development considered that detention/retention facilities be able to control floods as large as the 100-year event.

Each of the two types of stormwater storage has positive as well as negative features. If designed and maintained properly, there is general agreement that some flow control within a watershed can be provided. Additionally, the utilization of the facilities on individual sites will tend to provide flow control throughout most of the watershed, resulting in lower peak flows along small tributaries as well as the larger creeks. However, there are possible storm patterns, rainfall distributions and/or facility locations for a watershed area that might cause increases in flow rates in certain areas due to a detention pond. Additional storage volume can be designed into these facilities to offset many of these storm events that could cause flow increases, but the additional land, maintenance and cost requirements could significantly escalate.

2. Offsite or Regional Detention/Retention--Much of the above explanatory discussion for onsite facilities applies here as well, with certain exceptions. Offsite or regional detention/retention facilities are located in strategic watershed areas in such a manner as to provide flood protection for downstream areas. These facilities are termed "offsite" or "regional" since they are designed to control flows from a few hydrologically-chosen locations, rather than at each development site. There are several advantages to utilizing detention/retention facilities on a regional scale, as listed below:

- a. An increased level of confidence in the hydrologic design is obtained since each pond's interrelationship within a given basin is studied. This is accomplished by utilizing a hydrologic model of the entire basin to determine the most hydrologically efficient location for stormwater controls. This procedure considers the interrelationship of tributary subareas within a watershed.
- b. Maintenance is more assured than at on-site facilities due to the City's vested interest and responsibility in the facility, as well as the smaller number of facility locations.
- c. Construction costs, along with land requirements, can be considerably less than those needed for comparable on-site protection.
- d. The centralized land area required for regional ponds lends itself to other uses (e.g., parks, nature areas, playing fields, etc.).

Consideration must also be given to disadvantages such as the requirements of distributing facility financing to the appropriate entities and the lack of flood protection in certain locations such as areas upstream or considerably downstream of the facilities. Although methods are available to distribute the facility financial burden to the appropriate entities, it does require a considerable amount of effort to develop a program to collect funds and to coordinate related activities (project development, fund accounting, etc.).

3. Floodplain Storage Preservation--The preservation of floodplain storage involves maintaining a significant amount of the floodplain area for the spread of flood-waters during a significant storm event, for the purpose of controlling increases in flow rates due to decreased upstream floodplain storage. As flood flows progress in a downstream direction, there is a certain amount of attenuation of peak flows in downstream reaches if the flood flows can spread

out in up-stream floodplain areas and be "stored" temporarily. Although flood flows that spread out into a floodplain area are transient in nature, the fact that they occupy the floodplain area implies that they have been slowed and temporarily stored in their course to downstream reaches. Should the floodplain area become unavailable to floodwaters due to activities/structures (e.g., filling of over-bank areas, channel improvements, levees and/or floodwalls), flood flows will tend to move downstream much more quickly and at higher flow rates. Flooding at downstream points with limited flow capacity can result. Should there be adequate capacity throughout the drainage system, problems may not result from reducing the floodplain storage.

4. Flow Diversion--Flow diversion means the redirection of flows (i.e., flood flows) away from an original flow path to a new flow path, usually for the purpose of preventing flooding along, or downstream of, the original path. Flow diversions must be carefully considered such that adverse flooding or erosion problems do not arise along the new flow path.

5. Channel Improvements--Improvements to channels generally involve increasing the flow carrying capacity of the channel, realigning the channel and/or providing erosion protection to the channel sides and/or bottom. Generally, channel improvements can be a very (if not the most) effective means of providing flood control. In most instances, the improved channel will be trapezoidally-shaped and lined with grass, concrete or both.

A sometimes significant disadvantage of constructing channel improvements must be considered. When such improvements are made in headwater or watershed upstream areas, significant downstream peak flow rate increases often result. This results from the decrease in floodplain storage and the increase in the efficiency of the channel system(s) in transporting flood flows to downstream areas that could have flow capacity limitations. If areas downstream of the improvements are not of concern from a flooding standpoint

or they themselves are improved, then this disadvantage may not apply. It is also pointed out that channel improvement costs increase in the lower portions of an overall improvement project due to the peak flow increases caused by the upper portion improvements.

6. Removal/Modification of Flow Constrictions--The removal or modification of flow constrictions is generally done to increase the constricted area's flow capacity to that of the upstream and/or downstream drainageway, and thus to reduce water levels (i.e., flooding) at and/or upstream of the constriction. Constrictions also often cause erosion problems as the increased water level upstream of a constriction "forces" the water through the constriction and into the downstream reach at erosive velocities. In many instances, constrictions are associated with a bridge or culvert opening, although fill encroachments can also be a problem.

Constrictions tend to cause a "backwater effect" on flood flows, which translates to increased flow depths and decreased flow velocities upstream of the constriction. Removal of a constriction will, of course, lower floodwater levels at, and upstream, of the constriction point, and allow flow to move smoothly through the area. However, removal of a significantly large storage area(s) upstream of a constriction, or number of constrictions, can potentially increase downstream discharges for the same reasons given for channel improvements.

7. Levees/Dikes--Levees and dikes are typically trapezoidal-shaped linear embankments, often constructed to prevent floodwaters from entering an area located within a floodplain. Previously developed areas subject to flooding cannot feasibly be raised above flood levels with fill, making levees or dikes a possible flood control option.

These structures can be very effective, but there are disadvantages as well. For instance, drainage within the protected area must somehow be directed to the

creek or river. This can be done with pipes through the levee/dike with flap gates that only allow water to flow toward the creek. However, during high flows in the creek, the local drainage might cause flooding problems. A sump area with a pump can also be used, but equipment, construction and maintenance costs can be high. Like several of the previously discussed methodologies, levees and/or dikes can also reduce floodplain storage and increase downstream peak discharges.

8. Mechanical Floodproofing of Existing and/or New Structures--The mechanical floodproofing of structures involves modifying or constructing the structure and its components such that floodwaters cannot enter through the walls, doors, windows, floors or other locations. This implies that the protected structure is, or will be, located within the floodplain. Construction should consider not only the requirements of the water pressure head along the structure perimeter, but also the forces incurred with moving water and what it might carry.

9. Elevate Foundations of Existing and New Structures--The elevation of structure foundations is a means of preventing flooding by constructing slab or floor elevations some amount (usually between one and three feet) above a known flood elevation (usually the 100-year flood elevation). In many instances, foundations are elevated by fill over a general area, fill within (and adjacent to) the structure footprint and by the thickness of a concrete slab. If significantly large, the portion of the fill, and possibly the slab, below the flood elevation can become a flow constriction and cause upstream flooding or reduce floodplain storage, and thus increase downstream peak flow rates.

10. Relocation/Acquisition of Structures--The relocation and/or acquisition of flooded structures attempts to prevent future flood damages by eliminating the damageable property. This alternative becomes more viable when it is obvious that other flood control solutions would be considerably more expensive for the amount of flood control gained and/or the structure owners are willing to

relocate or sell the structure/property. A disadvantage can be that owners of other flooded property will want the City or flood control provider to also buy their property. Another disadvantage is that street flooding in the area could continue to be a hazard.

11. Subdivision and/or Zoning Regulations--These regulations provide flood protection by establishing certain criteria and procedures to be followed, as well as regulating the type of land use that is allowed in floodplain areas.
12. Public Acquisition of Open Space--The acquisition of open space along stream corridors for recreational or other uses will provide flood protection by disallowing development to take place in part, or all, of the floodplain.
13. Flood Early Warning System/Evacuation Plan--Warnings of an imminent flood and the resulting evacuation of people and certain property is a worthwhile means of flood protection in some areas and/or situations. Utilizing quick-response personnel and/or measures can save lives, reduce serious inconveniences and allow residents to protect certain damageable property. However, in relatively small watersheds, especially those that are urbanized, it is extremely difficult to provide warnings, evacuations and flood protection due to the short time between intense rainfall and flooding.
14. Flood Insurance--Flood insurance through the Federal Emergency Management Agency is available if the community is a participant in the National Flood Insurance Program. The City of Longview is a participant in the program. Although this alternative does not provide physical flood protection, there is some financial protection that is available to owners of floodplain properties should they choose to buy the insurance.
15. No Action--This self-explanatory alternative indicates that no changes to existing conditions are made.

In order to determine the most feasible structural and non-structural solutions to utilize in resolving drainage problems, a screening process was applied to the approximately 137 study reaches established throughout the study area. Generally, the solutions listed as means to decrease peak flows and stages tend to be structural in nature while the remaining items are mostly considered non-structural. The feasibility of utilizing a particular solution in a study reach was determined primarily on the potential ability of the alternative in alleviating or significantly reducing any existing or potential future flooding problems within the reach.

Master drainage planning opportunities vary among study reaches given their respective physiographic conditions, present development patterns and locations of flooding problems. Not surprisingly, an alternative plan of improvement that is appropriate for one portion of the study area may or may not be well-suited for another area. There is some independence between certain reaches and similarities among others.

Utilizing input from City staff with the screening procedures, alternatives were selected for the reaches throughout the study area. These final alternative solutions were determined to be channel and road crossing improvements, regional detention, acquisition of flood prone structures, floodplain dedication and "no action."

4.4 EVALUATION OF SELECTED ALTERNATIVE SOLUTIONS

Following selection of the most feasible alternative solutions, a more detailed analysis of the selected alternatives was made with the goal of developing a recommended master plan of the study area, and improvements associated with the selected alternative were evaluated. The structural alternatives were conceptually located, sized, hydrologically/hydraulically analyzed and costed. The nonstructural alternative evaluations simply determined requirements to satisfy the needs associated with preventing or reducing future problems from occurring. Results of the evaluations are based on alternative effectiveness as related to the evaluation factors discussed previously.

A discussed in Section 3.1, maintenance is an important aspect in assuring that improvements function properly, although costs can be significant. Additionally, should the City undertake channel, roadway and/or stormwater detention improvements, maintenance of the constructed facilities would become a City responsibility. Cost of such responsibility could be gradually incurred as improvement projects are funded, scheduled and constructed. A discussion of the annual maintenance costs per mile of improvements is provided in Section 3.1.

Although benefits and costs were generally considered in evaluating alternative solutions, it was not possible to determine detailed benefits and costs within the scope of Longview's Master Plan development. It requires a tremendous effort to develop such detailed information and if available funds had been utilized to develop such information it would have limited Longview's ability to cover the entire City in analyzing drainage and flood control improvements.

The general costs developed are good for planning purposes. However, the benefits derived from the improvements are much more difficult to estimate. These general benefits include providing flood protection to flood prone structures, making road crossings safe from floodwaters, improving water quality conditions by reducing erosion, and preventing loss of work production during flood periods.

4.4.1 Channel, Roadway Crossings and Small Problem Areas Design

The following paragraphs describe the general procedure used to design channel and roadway crossing improvements for watersheds within the project area with drainage areas larger than 100 acres. A similar description for small problem areas (<100 acres) is presented in Appendix D. Design reaches were determined based on the homogeneity of each stream reach using the existing slope, relative depths, estimated design flows, and other physical elements. The basic design methodology used was Manning's equation for uniform flow as discussed below. Further discussion of this equation is presented in the proposed Drainage Criteria Manual.

There were certain areas or situations where designs were not developed. First, designs were not developed and costed for railroad crossings, since they typically design and construct their own facilities. The City will have to coordinate with the railroad companies to get any needed improvements made. Additionally, no main-stem improvements were developed along Hawkins Creek since the HEC-1 modeling of future development did not show an increase in 100-year peak discharges above existing levels. The modeling indicated that projected (future conditions) urbanized runoff east of Hawkins Creek and within the City of Longview tends to exit the watershed in advance of the nonurban runoff assumed for areas outside of Longview's city limits. This separation of flows mitigates the effects of Longview's urbanization on Hawkins Creek.

Improvement designs were not made for Garfield Street over Wade Creek or Sabine Street over Grace Creek since the Department of Highways and Public Transportation will soon construct bridges in those two locations. However, some enlargement to the Garfield Street bridge will likely be required to optimize channel designs upstream of the structure. Additionally, channel improvements were not designed for the reach along Iron Bridge Creek from Millie Street to Raney Street since the recently constructed concrete-lined channel adequately conveys flows through the reach. However, road crossing enlargements were designed for the reach as shown in Appendix C. Finally, no improvements are proposed for the IH 20 crossing over Eastman Lake Creek due to the potential impact to the Texas Eastman lakes just downstream of the roadway. The existing IH 20 culverts will tend to dampen peak flow rates as they pass through the crossing area. This may become an increasing problem as the Eastman Lake watershed develops.

Design Procedure

The design flows for these evaluations were taken from the 100-yr HEC-1 results for each watershed assuming ultimate development conditions combined with Master Drainage Plan channel improvements. Due to the loss of floodplain storage and decreased runoff times that occurs when basin-wide channel and roadway crossing improvements are made, these 100-year design discharges are considerably larger than those for existing and future development conditions without Master Drainage Plan channel improvements discussed previously (see Table 3-1). Distribution of the design flows within each sub-watershed area were based on tributary confluence

locations and reach lengths. In order to simplify the design process, three general types of channel designs were considered, including a grass-lined channel, a combination channel with concrete bottom and grass-lined side-slopes and a totally concrete channel as shown in Figure 4-2.

When possible, the existing longitudinal bottom slope was maintained for a given design reach. Drop structures were used to decrease the existing grade in areas with slopes greater than the resulting flow velocity and other design considerations would allow. In these cases, drop structures were limited to about 4 feet although the number of drops and, therefore, the drop distance per drop can be decided during final design.

A basic trapezoidal channel configuration was assumed for each of the three channel types described above. The grass-and-concrete combination channel design assumed a concrete channel for one-half of the required depth with the remaining slope covered by grass. The following side slopes were used for each type:

Grass:	3:1
Grass/concrete:	3:1(grass)/1:1(concrete)
Concrete:	1:1

The component of surface roughness in Manning's equation, represented by the "n" factor, was based on the type of channel lining to be used for a given design reach, either concrete or grass. The following values were assumed for each channel type:

Grass:	.04
Grass/concrete:	.04/.015
Concrete:	.015

Aerial photos were examined in order to determine top-width limitations for each design reach based on existing development adjacent to the stream bed and the local vegetation. The available depth was estimated using watershed HEC-2 cross sections (where available), water surface elevation of the 10-yr flow, and the City's 1"=200' topographic maps. The 10-year flow elevations were used in areas where the 10-year water surface elevation approximated full-channel

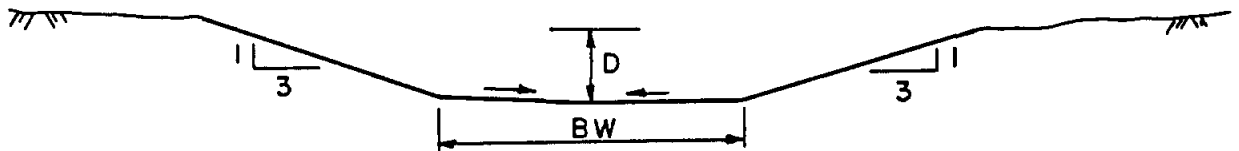

(a) TRAPEZOIDAL GRASS CHANNEL

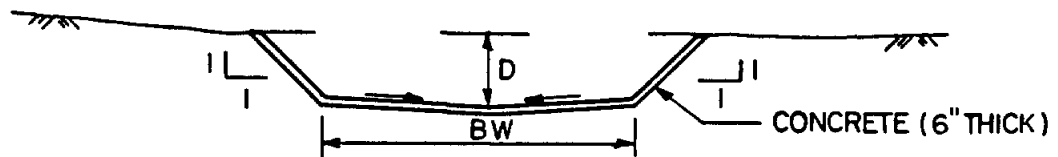

(b) TRAPEZOIDAL CONCRETE CHANNEL

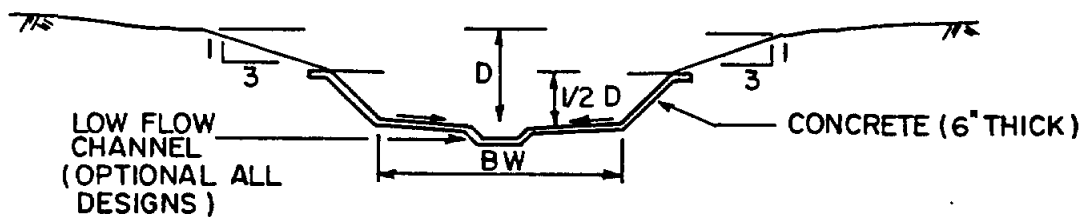

(c) TRAPEZOIDAL CONCRETE/GRASS CHANNEL



ESPEY, HUSTON & ASSOCIATES, INC.
Engineering & Environmental Consultants

FIGURE 4-2
TYPICAL DESIGN CHANNEL
CROSS SECTIONS

depth. A minimum slope was required which would maintain a velocity of 3 fps at 20% of the 100-yr flow (an event that could be expected frequently).

In addition, the maximum permissible velocity for each channel design was assumed to be 8 fps for the grass-lined channels, 12 fps for the combination grass/concrete channels and 15 fps for the concrete channel design.

Due to wide floodplain conditions and shallow available channel depths, the following stream reaches were only designed large enough to carry future 100-year peak discharges (including increases due to Master Plan improvements) to the extent that existing 100-year flood elevations would not be exceeded:

- Grace Creek below Loop 281 to FM 1845
- Harris Creek below Lake Lamond to its confluence with Grace Creek
- Eastman Lake Creek and Drain No. 1 below U.S. Highway 80 to IH 20

Although significantly large channels have been designed for these above-listed reaches, the designs will not totally carry the future 100-year flows (assuming Master Plan channel and roadway crossing improvements are in place) as other design reaches have been designed to do. The considerable amount of fill required to prevent excessively wide channel designs and the overall costs of the full 100-year designs made the reduced designs the much preferred option.

Design Results

The results of the design analyses for channel and road crossing improvements are given in Tables B-1 through B-17 in Appendix B for each of the watersheds in the project area. These design feature tables include:

- 1) watershed identification, including primary design reaches and individual design reaches,
- 2) G.I.S. numbers that relate the improvements to the G.I.S. mapping system,

ESPEY, HUSTON & ASSOCIATES, INC.

- 3) design type (grass, grass/concrete and concrete),
- 4) design discharge,
- 5) bottom width,
- 6) depth,
- 7) number of drop structures,
- 8) design reach length,
- 9) top width, and
- 10) required easement.

Required easement widths (item 10 above) were generally set at 20' wider than the proposed channel top widths to provide for access. No attempt was made to determine if easements already exist along any particular creek although a vast majority are believed to be without easements according to the City staff.

Costs

Costs associated with the channel and roadway crossing designs were estimated using the following:

- 1) Unit Costs
 - excavation \$4/cy
 - embankment \$4/cy (where required)
 - concrete lining & drop structures \$300/cy
 - grass seeding \$0.08/sf (\$0.70/sy)
 - crossing structure (i.e., crown span, bridge or culvert)
 - thoroughfares/collectors \$40/sf
 - others \$35/sf

Tables C-1 through C-21 in Appendix C present the costs associated with these improvements. Costs include a 20% engineering and contingency fee. However, costs for utility improvements, land/right-of-way acquisition and railroad bridges were not included.

Prioritization

The many channel and roadway crossing improvements were prioritized according to the following guidelines (listed in order of their importance).

- 1) no hydrologic impact - Improvements were sequenced to avoid impacts on others. This generally means improvements progress from downstream to upstream unless hydrologic "timing" of runoff allows another sequence.
- 2) effectiveness and safety - This relates to the degree that improvements solve flooding or other problem(s) within a design reach. Effectiveness is greater for those reaches with significant problems being resolved.
- 3) Costs

A similar evaluation was performed on the small problem areas discussed in Appendix D. Costs presented in Appendix D include an engineering and contingency fee.

These major and minor system improvements were merged and prioritized. The combining of the prioritization of these systems was accomplished according to the following procedure.

- 1) Independently prioritize the major system - Improvements were hydrologically sequenced or prioritized such that downstream impacts would not be caused as shown in Figures 4-3 and 4-4. HEC-1 modeling and other hydrologic/hydraulic analyses were performed to verify that peak discharges are not increased downstream of improvements. HEC-1 model input and output listings are provided to the City under separate cover.
- 2) Independently prioritize the minor system - Improvements were hydrologically evaluated with respect to potential downstream impacts. If downstream

improvements are required, such was noted as part of the general prioritization classification given each small project. Table D-2 presents the general priorities for each of the small problem areas.

- 3) Priorities of the minor systems were merged into the major system prioritization. The minor system improvements not requiring downstream improvements were added to those similar major system improvements that can be built at any time (i.e., no downstream or other improvements required). The minor system improvements requiring downstream improvements were attached to the priority group and major system "primary design reach" into which it flows. Prioritization factors, in addition to hydrologic impacts, were also considered in making the overall prioritizations. These additional factors included safety, damage reduction and costs.

Table 4-2 presents the overall prioritization listing. However, this listing should be considered with some flexibility. For instance, Group 1 improvements could be taken in other sequencing methods or patterns should other considerations arise. A "best effort" was made to develop the prioritization but, in many instances, there was little difference between reach priority assignments. However, the hydrologic prioritizations presented in Figures 4-3 and 4-4 should be respected unless additional study indicates that other priorities are acceptable.

4.4.2 Regional Stormwater Detention Facilities

An analysis was performed in the Grace Creek Watershed to assess the feasibility of stormwater detention to attenuate flood peaks throughout the watershed. Regional detention was judged to be inappropriate or unwarranted in the other watersheds. The following two conditions were modeled with the HEC-1 model in the analysis:

- existing land use throughout the watershed and with modified puls channel routings where storage routing data is available.

TABLE 4-2
 PRIORITY LISTING FOR
 IMPROVEMENTS RELATED TO
 CHANNELS, ROADWAY CROSSINGS AND MINOR DRAINAGE

Priority No.	Study Reach	Group	System Type	Cost Estimate (\$ x 1,000)		
				Primary	Secondary	Local
1	GU(T)-1	1	X		842	
2	PC-1	1	X	2,613		
3	WD(T)-1	1	X		720	
4	GUT-16	--	A1			24
5	GUT-3	--	A1			29
6	GUT-2	--	A1			59
7	UHA-11	--	A1			4
8	UHA-13	--	A1			7
9	UHA-12	--	A1			9
10	UHA-8	--	A1			14
11	WAD-7	--	A1			14
12	SCH-2	--	A1			14
13	GIL-2	--	A1			4
14	LHA-2	--	A1			3
15	ELC-18/19	--	A1			11
16	LHA-8	--	A1			3
17	LHA-5	--	A1			11
18	LGR-14	--	A1			11
19	LGR-8	--	A1			27
20	ELC-1	--	A1			12
21	SCH-4	--	A1			36
22	MGR-6	--	A1			52
23	SCH-5	--	A1			68
24	LAF-2	--	A1			80
SUBTOTAL				\$2,613	\$1,562	\$492

4-23

TABLE 4-2 (Cont'd)

Priority No.	Study Reach	Group	System Type	Cost Estimate (\$ x 1,000)		
				Primary	Secondary	Local
25	LGR-1	--	A1			92
26	GIL-4	--	A1			58
27	IBC-14/15	--	A1			177
28	WAD-2	--	A1			172
29	LGR-10	--	A1			351
30	LGR-4	--	A1			11
31	LGR-11	--	A1			36
32	LGR-3	--	A1			63
33	WAD-8	--	A1			150
34	GU-1	1	X	1,406		
35	GUT-1	--	A1			27
36	WD-1	1	X	2,209		
37	GR(T)-2A	1	X		321	
38	LA-1	1	X	623		
39	GI-1	1	X	1,482		
40	HA(T)-1	1	X		355	
41	HA-1	1	X	6,451		
42	GU(T)-2	2	X		48	
43	GU-2	2	X	3,138		
44	JO-1	2	X	1,153		
45	JO(T)-1	2	X		293	
46	GUT-14	--	A2			28
47	JON-1	--	A2			30
48	JON-2	X	A2			29
49	IBC-16	--	A2			13
50	JO-2	2	X	1,218		
51	GU-3	2	X	562		
52	GU-4	2	X	302		
53	OA-1	2	X	<u>1,741</u>		
SUBTOTAL				\$20,285	\$1,017	\$1,237

4-24

TABLE 4-2 (Cont'd)

Priority No.	Study Reach	Group	System Type	Cost Estimate (\$ x 1,000)		
				Primary	Secondary	Local
54	CH-1	2	X	1,574		
55	CHS-3	--	A2			46
56	IB-1	2	X	125		
57	IB-2	2	X	518		
58	IB-3	2	X	562		
59	IB-4	2	X	382		
60	WD-2	2	X	1,451		
61	WD(T)-2	2	X		1,396	
62	WD-3	2	X	3,654		
63	WAD-3	--	A2			82
64	HA-2	2	X	3,665		
65	GU-5,6	2	X	1,709		
66	GUT-6	--	A2			27
67	WAD-5	--	A2			248
68	GUT-7	--	A2			110
69	GU(T)-3	2	X		273	
70	GUT-24	--	A2			1,057
71	OA-2	2	X	4,510		
72	IB-6	2	X	1,030		
73	LA-2	2	X	94		
74	LA-3	2	X	367		
75	GI-2	2	X	597		
76	GR-1, 2, 3	1	X	7,353		
77	GR(T)-2	1	X		258	
78	DR4-1	3	X	2,851		
79	UHA-10	--	A2			46
80	HA(T)-2	3	X		362	
81	HA-3	3	X	929		
SUBTOTAL				\$31,371	\$2,289	\$1,616

4-25

TABLE 4-2 (Cont'd)

Priority No.	Study Reach	Group	System Type	Cost Estimate (\$ x 1,000)		
				Primary	Secondary	Local
82	HA-4	3	X	376		
83	HA(T)-3	3	X		159	
84	UHA-1	--	A2			36
85	HA-5	3	X	1,239		
86	UHA-9	--	A2			44
87	UHA-2	--	A2			50
88	GR(T)-1	1	X		418	
89	GI(T)-1	1	X		1,196	
90	EA(T)-4	1	X		1,958	
91	GI-3	3	X	307		
92	OA-3	3	X	1,113		
93	GR(T)-5	1	X		740	
94	GR(T)-6	1	X		380	
95	GR(T)-4	1	X		54	
96	GR(T)-3	1	X		158	
97	LA(T)-1A,1B	2	X		303	
98	LA(T)-2	2	X		63	
99	LA(T)-1C	2	X		143	
100	GR-4	2	X	6,367		
101	GR-5	2	X	4,333		
102	GR-6	2	X	3,975		
103	GR-7	2	X	1,113		
104	GR-8	2	X	2,530		
105	GR-9	2	X	326		
106	GR-10	2	X	994		
107	SB(T)-1	4	X		61	
108	SB-1B	4	X	249		
109	DR3-1	4	X	1,116		
110	SCH-3	--	A2			111
SUBTOTAL				\$24,038	\$5,633	\$241

4-26

TABLE 4-2 (Cont'd)

Priority No.	Study Reach	Group	System Type	Cost Estimate (\$ x 1,000)		
				Primary	Secondary	Local
111	SB-2	4	X	1,279		
112	IB(T)-1	1	X		1,632	
113	RA-1B	4	X	3,079		
114	RA-2	4	X	1,170		
115	EL-1	4	X	776		
116	EL(T)-1	4	X		7	
117	DR2-1B	4	X	1,888		
118	EA(T)-1	1	X		201	
119	OA(T)-1	3	X		640	
120	IBC-4 TO 13	--	B1			1,202
121	LHA-4	--	B1			55
122	LHA-6	--	A2			107
123	UGR-1	--	A2			13
124	OAK-1	--	A1			0.3
SUBTOTAL				\$ 8,192	\$ 2,480	\$1,377.3
TOTAL				\$86,499	\$12,981	\$4,963.3

-- All remaining B1 and B2 small problem areas taken as desired (see Table D-2) = \$2,708,500.

-- All remaining C1 and C2 small problem areas taken as desired following B1 and B2 improvements (see Table D-2) = \$1,159,000.

NOTES:

1) Study Reaches: see Figure 4-1 (GR-11, GR-12A, SB-1A, RA-1A and DR2-1A not prioritized since ponding area upstream of Loop 281 to remain unchanged or enlarged).

Major systems: CH-Coushatta Hills; DR1-Drain 1; DR2-Drain 2; DR3-Drain 3; DR4-Drain 4; EA-Eastman Lake; EL-Elm; GI-Gilmer; GR-Grace; GU-Guthrie; HA-Harris; HK-Hawkins; IBC-Iron Bridge; JO-Johnson; LA-LaFamo; MC-McCann; MU-Murray; OA-Oakland; PC-Peterson Court; RA-Ray; SB-School Branch; WD-Wade.

TABLE 4-2 (Concluded)

2) Group Descriptions:

- 1 - Reaches not requiring any prior improvements;
- 2 - Reaches requiring only improvements in same basin;
- 3 - Same as Group 2 except requires GR-1 through GR-3 improvements;
- 4 - Same as Group 2 except requires GR-1 through GR-10 improvements.

3) System Type:

X - Primary or Secondary System

A1, A2, B1, etc. - Minor Systems (see Appendix D)

A1 - Home flooding or public safety problem. No anticipated adverse downstream impacts due to construction of improvements.

B1 - Erosion problem. No anticipated adverse downstream impacts due to construction of improvements.

C1 - Temporary nuisance drainage problem. No anticipated adverse downstream impacts due to construction of improvements.

A2 - Home flooding or public safety problem. Anticipated adverse downstream impacts due to construction of improvements.

B2 - Erosion problem. Anticipated adverse downstream impacts due to construction of improvements.

C2 - Temporary nuisance drainage problem. Anticipated adverse downstream impacts due to construction of improvements.

- 4) Major systems not presently experiencing drainage problems (e.g., in Upper Grace, Upper Hawkins, Eastman Lake, and Drain No. 1 creeks) are not listed since improvements therein are most likely to be made by the private sector when developed. A design based on future development including Master Plan improvements has been prepared and is present in Appendices A and B.

- fully urbanized watershed with channel routings computed by the Muskingum method assuming a travel velocity of 5 ft/sec to account for proposed channel improvements. The existing ponding area formed upstream of Loop 281 at Grace Creek was also modeled.

Initially, seven detention sites were considered along with the existing area upstream of Loop 281 (see Exhibit B and the Work Map in the map pocket at the back of this report). In a separate analysis discussed subsequently, the area upstream of Loop 281 was assumed to be enlarged such that additional detention could be achieved. These seven sites were modeled as a gross approximation of the maximum benefit that could be achieved. This was accomplished in the modeling effort by simply eliminating the drainage area upstream of the following locations:

<u>HEC-1 MODEL NODE</u>	<u>WATERSHED</u>
8	Upper Grace Creek
22	Ray Creek
28	Drain 2
36	School Branch
57	Oakland Creek
63	Coushatta Hills
73	Harris Creek

Table 4-3 presents results of the comparative analysis for the 100-year flood event for future watershed conditions including Master Plan improvements with and without the maximum (actually full retention) detention upstream of the above-listed HEC-1 nodes. Significant reduction in flood peaks along Grace Creek can be achieved as noted.

The Grace Creek floodplain downstream of Loop 281 has remained more free of encroachment than certain of its tributaries and is somewhat protected by the existing ponding area upstream of the Loop. In certain streams draining into Grace Creek, flood damages are being experienced and stormwater detention was judged to be a viable alternative solution to addressing these damages and possible solutions. Analyses of four sites were conducted in more detail to test

TABLE 4-3
 PRELIMINARY STORMWATER DETENTION FEASIBILITY ANALYSIS
 (PEAK DISCHARGE COMPARISON)
 GRACE CREEK WATERSHED

HEC-1 Model Node	100-Year Flood (cfs)		Percent Reduction
	Future Watershed	Future Watershed W/Detention	
14	10,132	3,282	67.6
15	26,835	5,206	80.6
45.1	29,569	10,931	63.0
52	34,344	21,163	38.4
69	39,732	24,739	37.7
80	40,015	25,043	37.4
81	40,869	26,283	35.7
88	41,162	26,697	35.1

- Notes: 1) Full watershed runoff retention upstream of nodes: 8, 22, 28, 36, 57, 63, 73. Existing ponding at Loop 281.
- 2) All nodes located along Grace Creek main stem.

the value of stormwater detention on these tributaries to Grace Creek. The four sites considered in the detailed analysis are located by watershed and node below:

<u>HEC-1 MODEL NODE</u>	<u>STREAM</u>
22	Ray Creek
57	Oakland Creek
63	Coushatta Hills
73	Harris Creek

The analysis procedure follows the method presented in Chapter 6 of the U.S. Soil Conservation Service Technical Release 55 "Urban Hydrology for Small Watersheds" (SCS, 1986). The proposed pond volumes are estimated by relating two ratios: peak outflow to peak inflow, and storage volume to runoff volume.

If outflow is taken as the peak runoff rate for existing conditions within the watershed, and peak inflow rate is the future condition (with Master Plan channel and roadway crossing improvements) watershed peak runoff; the storage volume required to achieve peak attenuation (i.e. reduce the future peak to the level of the existing peak) is computed from the ratio of the storage volume from TR-55 Figure 6-1 (USDA, 1986) and the storm runoff volume.

As mentioned briefly above, a separate analysis was preformed to evaluate increased detention along Grace Creek upstream of Loop 281. Initial detention analyses discussed above considered only the existing amount of stormwater detention that occurs upstream of Loop 281 where Grace Creek, Drain No. 2, Ray Creek and School Branch join together. The backwater effect of Loop 281 on flows approaching and passing through the Loop's culverts as well as the flat areas upstream of the Loop combine to create a significant existing detention location within the present drainage system. This detention presently provides a certain amount of desirable peak flow control along the lower reaches of Grace Creek although more flow control is needed. The need for additional flow control is even more pronounced when future discharge increases in the upper

Grace Creek watershed are considered. Therefore, a HEC-1 analysis was performed to determine the reductions in peak flow that could be obtained with expansion of detention above the Loop.

Using the existing configuration of the large existing ponding area upstream of Loop 281, it was estimated that approximately 250 ac-ft of stormwater detention storage could be added to the ponding area. It was felt that this added volume could be added by excavating around the periphery of the existing ponding area. This expanded storage area would actually reduce flood evaluations in the country club golf course area due to the added storage volume. It was assumed that the entire area might be expanded to a regional recreational area while maintaining the present golf course use in generally its present location. As part of the overall plan, certain greens and even portions of fairways on the course could be raised to reduce their flood prone nature.

Table 4-4 presents results of the Ray, Oakland, Coughatta Hills, Harris and Grace Creek/Loop 281 analyses. The benefits achieved from stormwater detention at these five sites are most prominent in the stream reaches immediately downstream of the detention locations. The advantages of these sites are the reduced channel improvement cost to convey the fully urbanized flows through the reach and the flood peak attenuation offsetting the flood peaks generated by upstream watershed urbanization and stream channel improvements.

Costs to construct are primarily related to items such as excavation, embankment, seeding, erosion control, dam top cover, spillway lining, outflow and conduits. Very general estimates were made concerning the five sites analyzed in greater detail. Costs associated with land acquisition and utilities are not included at the direction of the City. Facility construction costs are given below for Ray, Oakland, Coughatta Hills, and Harris Creek areas. However, feasibility of the Coughatta Hills, Harris and Grace Creek facilities is significantly greater than that of the Ray and Oakland Creek facilities. This is primarily due to the significant damage reduction achieved in the areas downstream of the investigated Coughatta Hills, Harris and Grace Creek facility sites. Another factor that makes these three stormwater detention facility sites attractive is the opportunity to make certain channel and roadway crossing improvements upstream of these facilities (to the degree the facility can mitigate these improvements in downstream areas).

TABLE 4-4
 FINAL STORMWATER DETENTION FEASIBILITY ANALYSIS
 (PEAK DISCHARGE COMPARISON)
 GRACE CREEK WATERSHED

Node	100 Year Flood (cfs)*			
	Existing	Future	Future with Detention	Loop 281 Detention
<u>Ray</u>				
22	4,829	8,339	4,091	
<u>Oakland</u>				
57	2,250	3,252	2,330	
61	3,043	4,512	3,137	
55	5,388	9,283	4,564	
<u>Coushatta</u>				
63	439	885	467	
64	673	1,500	866	
61	1,223	2,248	1,603	
<u>Harris</u>				
73	2,438	4,145	2,746	
75	4,165	6,527	4,255	
78	5,113	7,872	5,059	
<u>Grace</u>				
151	14,310	28,863	23,546	28,863
15	14,310	26,835	21,884	22,940
52	18,067	34,344	29,534	28,637
69	21,993	39,657	34,277	34,818
88	22,608	41,162	35,774	37,532
<u>Guthrie</u>				
55	5,388	9,283	7,387	
68	6,367	11,734	10,058	
52	18,067	34,344	29,534	

*Future - this condition reflects future land use changes as well as Master Plan channel and roadway crossing improvements,
 Future w/Detention - same as "Future" but includes stormwater detention at nodes 22, 57, 63 and 73.
 Loop 281 Detention - only detention at node 15 (Loop 281) is considered.

Stream	Node	Drainage Area	Gross Cost Estimate
Ray Creek	22	3.8	\$2,300,000
Oakland Creek	57	1.23	1,100,000
Coushatta Hills	63	0.27	250,000
Harris Creek	73	1.93	1,650,000
Grace Creek/Loop 281	15	16.30	5,000,000

4.4.3 Acquisition

Although generally not a preferred solution to problem areas, acquisition of properties (e.g., houses) in the floodplain can sometimes be warranted due to the cost savings compared to other alternatives. However, it may be somewhat cumbersome when attempts are instituted to buy houses since there may be considerable opposition (condemnation required) or, the opposite, many homeowners soliciting acquisition by the City. This alternative was, therefore, considered with the potential "drawbacks" in mind.

However, it appears that approximately twelve (12) houses along lower Grace Creek (between Pecan Street and the Missouri Pacific Railroad) and four (4) houses along Elm Creek (between Spur 502 and Miles Street) and two (2) houses along Peterson Court Creek may be candidates for acquisition.

Very general costs per house in these respective areas were estimated in consultation with City staff to obtain the costs given below.

4.4.4 Floodplain Dedication

Floodplain dedication is a viable alternative solution to preventing future structures from being built in a floodplain and a means to preserve floodplain storage. Floodplain storage

preservation would assist in controlling peak discharge increases due to urban development since reductions in floodplain storage sometimes dramatically increases downstream peak discharges.

The City should encourage floodplain dedication in many instances to preserve floodplain storage. The U.S. Army Corps of Engineers is proposing limiting the loss of floodplain storage due to channel improvements, levees and filling from 0% to 20% in certain portions of the Dallas/Trinity River area.

4.4.5 No Action

There were numerous stream reaches studies that did not have a flooding problem. Most of these reaches were in undeveloped areas or in partially developed areas. The priority list presented in Table 4-2 of the report reflects these findings by assigning these reach improvements a relatively low priority.

POSSIBLE ACQUISITION COSTS

Creek Area	No. Structures	Total Costs
Lower Grace Creek	12	\$180,000
Elm Creek	4	200,000
Peterson Court Creek	2	100,000

5.0 RECOMMENDED MASTER PLAN

A recommended Master Drainage Plan for the City of Longview has been formulated from the present study. The Master Plan has been structured to allow future decisions by the City Council and City staff to ultimately select the extent that drainage planning is formalized and improvements are made. Therefore, the recommended plan presented herein should be viewed as a basic framework from which to build the ultimate plan. Future refinements or decisions made regarding recommendations presented herein should follow a review of the basic study elements presented in this report with an awareness of the costs and responsibilities incurred as a result of the decisions made. The recommendations presented herein can be viewed as options in obtaining City goals and in determining the degree to make drainage improvements within the City's jurisdictional area.

The previous report sections have outlined the problems and needs for the study area as well as developed, analyzed and costed potential solutions. From this information the recommended Master Plan was developed to include structural and nonstructural components that will resolve both existing and potential future problems. With only a few exceptions, channel and roadway crossing improvements adequate to provide a 100-year level of protection have been designed and costed for over 90 miles of major and minor drainage systems throughout the study area. Cost to construct all of the systems designed are estimated to exceed \$115 million. Land costs and utility replacement costs will increase the total even more. However, many of these improvements considered are located in undeveloped areas and will likely be funded and constructed by landowners and/or developers as these areas urbanize. As options to portions of the channel and roadway crossing improvements, five regional stormwater detention facilities have been preliminarily designed and costed at just over \$10 million. Another option identifies 18 house acquisitions for almost \$0.5 million.

The primary structural components of the plan are the prioritized channel, road crossing and small drainage area (minor system) improvements presented in Table 4-2 and Appendices B, C and D. The prioritization was made such that improvements would not adversely impact others while also giving the most cost effective improvements the highest priority. The most prominent

nonstructural measures are the acquisition options, floodplain dedication considerations and regulatory framework (policy, procedure and/or ordinance) changes recommended. Other important components compliment the primary ones to complete the plan as detailed below. As the city focuses on the level of improvements to be undertaken the prioritized improvement list can be updated and the final regulatory framework needed can be put in place.

Implementation actions are presented and are most important. An important element of the implementation process is funding. Since the amount of funding needed is directly related to the level of improvements the city decides to undertake (which is presently undetermined), several available options have been presented for future consideration in Appendix E. Once the City has determined the level of improvements to undertake from the options it has, the use of one or more funding options can be explored. The recommended plan is summarized below in outline form for easy reference.

RECOMMENDED MASTER PLAN COMPONENTS

I. STRUCTURAL IMPROVEMENT OPTIONS

A. Channels, Roadway Crossings and Minor Drainage Systems Improvements

1. over 90 miles of major drainage systems designed
2. improvement costs for major systems exceed \$115 million but many of the improvements likely to be constructed by landowners or developers
3. hydraulically equivalent drainage systems (e.g., storm sewers) can be substituted for major channel system designs but cost estimates will remain basically unchanged
4. approximately 150 minor system conceptual designs developed
5. minor system costs totalled almost \$9 million
6. improvements costed and prioritized for major and minor drainage systems
 - a. priority list (Table 4-2) easily modified such that certain categories of problem classifications (e.g., nuisance problems in small areas) can be removed with the remaining elements remaining prioritized

b. priorities can be somewhat flexible as discussed in more detail in Section 4.0.

7. utilize developed Geographical Information System (G.I.S.) in locating and describing existing systems as well as proposed improvements
8. consider increased maintenance responsibilities for improved areas

B. Existing Creek System Cleaning

1. a front-end cleaning and minor channel grading improvement proposed as part of upgrading maintenance program
2. progress according to creek improvement priority listing in areas that are significantly clogged

C. Stormwater Detention Improvements

1. expand/redesign ponding area immediately upstream of Loop 281 along Grace Creek
 - a. costs of improvements estimated at \$5 million
2. upper Harris (upstream of Loop 281 in undeveloped area)
 - a. costs of improvements estimated at \$1.65 million
3. upper Coushatta Hills (upstream of Hwy 259)
 - a. costs of improvements estimated at \$0.25 million

II. NONSTRUCTURAL IMPROVEMENT OPTIONS

A. Acquisition

1. lower Grace (12 houses)
 - a. upstream of Sabine Street and downstream of U.S. Hwy 31
2. Elm Creek (4 houses)
 - a. downstream of Judson Road
3. Peterson Court Creek (2 houses)

- B. Floodplain/Floodway Dedication**
 - 1. obtain park areas in preferred areas
 - 2. maintain present procedure of obtaining drainage easement as areas are subdivided/platted although natural channels should be allowed in subdivision ordinance

- C. Maintenance Planning**
 - 1. maintain existing herbicide program
 - a. monitor contractor performance and results
 - b. expand to include areas with vegetation problems
 - 2. expand maintenance activities to master plan improvement areas
 - 3. use G.I.S. system to track program

- D. Regulatory Framework/Institutional Requirements**
 - 1. adopt Drainage Criteria Manual
 - a. institute standard design procedures
 - b. develop erosion control procedures
 - c. require stormwater detention in certain areas depending on the status of downstream Master Plan channel and roadway crossing improvements
 - d. establish responsibility for future development runoff
 - 2. incorporate needed/proposed improvements into C.I.P. schedule

- E. Flood Warning**
 - 1. upgrade emergency management system to incorporate flood forecasting
 - 2. develop rain and stream gage network to allow forecasting of flood events
 - a. recommend rain gages located near Elm Branch confluence with Ray Creek, Loop 281, Wildwood Lake Dam, near Coushatta Hills watershed and near upper Iron Bridge Creek Watershed

- b. recommend flow gages located: Grace Creek at Loop 281 and Hwy 80; Oakland Creek below confluence with Couchatta Hills Creek and Guthrie Creek at Judson Road

F. National Pollution Discharge Elimination System Planning (NPDES)

- 1. plan for upcoming federal (Environmental Protection Agency - EPA) and state requirements
 - a. EPA regulations promulgated in October 1991 but does not affect the entire City of Longview's drainage system presently since population is below 100,000
 - b. the City should immediately determine its permit requirements covered under the "industrial activity" portion of the regulations including landfills (receiving industrial wastes), vehicle maintenance areas and the City's wastewater treatment plant
 - c. state pollution abatement program requirements likely promulgated in 1991 and will thereafter affect Longview unless proposed guidelines are changed
- 2. future regulations may require:
 - a. stormwater program development
 - b. identification of pollution (from runoff) sources
 - c. estimation of pollutant discharge amounts
 - d. location of illicit (i.e. illegal non-stormwater flows) connections
 - e. control of construction site runoff
 - f. ordinances to reduce pollutant discharges
 - g. public education
 - h. improved operation and maintenance programs
 - i. funding from local sources

G. FEMA Update

- 1. study results should be utilized to update FEMA floodplains since most present information is outdated (1977 information)

2. submit updated floodplain information to FEMA for map revisions

III. IMPLEMENTATION OPTIONS

- A. Determine Level/Extent of Structural Improvements to Undertake
 1. assess costs and added responsibility (e.g. any future problems concerning drainage, erosion, etc. as well as increased maintenance requirements)
 2. improvements to include all systems (major and minor), only major systems, no systems or some other level
- B. Adopt Final Master Plan
 1. obtain City staff and City Council input
- C. Establish Funding Methods
 1. options presented in Appendix E
 2. methods selected following decisions on extent of improvements
 3. NPDES considerations
- D. Reassess Staffing to Match Added Work Loads

6.0 REFERENCES

Federal Emergency Management Agency, 1977. Flood Insurance Study, City of Longview, Texas, Gregg and Harrison Counties.

_____. 1986. Flood Insurance Study, City of Longview, Texas, Gregg and Harrison Counties.

_____. 1990. Flood Insurance Study, City of Longview, Texas, Gregg and Harrison Counties.

_____. 1990. Flood Insurance Study, Gregg and Harrison Counties, Texas, Unincorporated Areas.

North Central Texas Council of Governments, 1982. Assessment of Local Government Implementation Programs for Stormwater Management.

_____. 1982. Survey of Local Flooding and Drainage Ordinances.

U.S. Department of Agriculture. 1983. Soil Conservation Service, Soil Survey of Upshur and Gregg Counties, Texas.

_____. 1986. Soil Conservation Service, Urban Hydrology for Small Watersheds.

Note: Appendix A references are provided at the end of Appendix A.

APPENDIX A

**Detailed Description of Hydrologic
(HEC-1) Modeling Methods**

APPENDIX A
TABLE OF CONTENTS

<u>Section</u>		<u>Page</u>
	List of Figures	A-iii
	List of Tables	A-iv
A1.0	<u>INTRODUCTION</u>	A-1
A2.0	<u>STORMWATER RUNOFF</u>	A-1
A2.1	STUDY APPROACH	A-1
A2.2	WATERSHED MODELING	A-2
	A2.2.1 <u>SCS Runoff Curve Number</u>	A-2
	A2.2.2 <u>Hydrologic Classification of Soils</u>	A-3
	A2.2.3 <u>Land Use</u>	A-5
	2.2.4 <u>Integrating Soils and Land Use</u>	A-9
	A2.2.5 <u>Time of Concentration</u>	A-10
A2.3	HYPOTHETICAL STORM EVENTS	A-14
	A2.3.1 <u>Rainfall Distributions</u>	A-14
	A2.3.2 <u>Depth-Area Relationship Simulation</u>	A-16
A2.4	DIMENSIONLESS UNIT HYDROGRAPH	A-17
A2.5	STREAM ROUTINGS	A-17
	REFERENCES	

APPENDIX A
LIST OF FIGURES

<u>Figure</u>		<u>Page</u>
A-1	Rational "C" vs. Residential Housing Density for 100-Year Event	A-7
A-2	Imperviousness vs. Residential Housing Density	A-8

ESPEY, HUSTON & ASSOCIATES, INC.

APPENDIX A
LIST OF TABLES

<u>Table</u>		<u>Page</u>
A-1	Subarea Average SCS Runoff Curve Numbers-Grace Creek Watershed	A-23
A-1a	Hypothetical Storm Events, Depth-Duration-Frequency, Longview, Texas	A-15
A-2	Subarea Unit Hydrograph Lag Times for Existing Conditions-Grace Creek Watershed	A-
A-3	Subarea Average SCS Runoff Curve Numbers for Existing and Proposed Conditions-Hawkins Creek Watershed	A-47
A-4	Subarea Unit Hydrograph Lag Times for Existing Conditions-Hawkins Creek Watershed	A-57
A-5	Eastman Lake Creek Watershed Curve Numbers and Percent Impervious (Existing Conditions)	A-61
A-6	Eastman Lake Creek Watershed Time-of-Concentration (Existing Conditions)	A-66
A-7	Eastman Lake Creek Watershed Curve Numbers-Fully Developed Watershed Conditions	A-72
A-8	Eastman Lake Creek Watershed Time-of-Concentration-Fully Developed Watershed Conditions	A-74
A-9	Iron Bridge Creek Watershed Curve Numbers and Percent Impervious (Existing Conditions)	A-76
A-10	Iron Bridge Creek Watershed Time-of-Concentration-Fully Developed Watershed Conditions	A-78
A-11	Iron Bridge Creek Watershed Curve Numbers and Percent Impervious (Existing Conditions)	A-81

A1.0 INTRODUCTION

A basic hydrologic or stormwater runoff model for the Longview Texas study area was developed using the generalized computer program HEC-1 (USCE, 1981) incorporating the U.S. Soil Conservation Service (SCS) methodology (USDA, 1971; USDA, 1975) for storm runoff determination. Procedures outlined in the SCS National Engineering Handbook, Section 4, Hydrology (NEH-4) (USDA, 1972), are adequate for determining volumes, peak rates, and hydrographs of runoff from urban areas. The increase in the volume of runoff due to urbanization depends more on the percentage of impervious area than on any of the other watershed constants. The soil-cover complex and associated runoff curve number procedure outlined in NEH-4 can be used to measure the change in runoff volume caused by urbanization. By using land use patterns found in an urban area and accounting for impervious area, a composite weighted curve number representing runoff potential from the watershed can be determined. Changes in the time-area relationship (lag time) can be estimated by hydraulic analysis of flow velocities and storage. Changes in channel routing can be estimated by hydraulic analysis of channel flow rate, velocities and storage.

As indicated in Section 3, modeling results are provided under separate cover due to its large volume.

A2.0 STORMWATER RUNOFF

A2.1 STUDY APPROACH

The HEC-1 computer model was used to develop hydrographs from watersheds in the study area based on soil types and conditions, land uses, elevation differences, and rainfall amounts associated with storms of a wide range of frequencies. Two models (existing conditions and future conditions) were developed relating to the degree of urbanization (percent impervious cover) to stormwater runoff for the 10, 50, 100, and 500-year storm rainfall frequencies.

A2.2 WATERSHED MODELING

A2.2.1 SCS Runoff Curve Number

In the SCS TR-55 methodology, the land use, hydrologic condition of the soil, and the hydrologic soil classification are used to define a runoff curve number, CN, for a particular drainage basin or sub-basin. The curve number is an indication of the runoff producing potential of the drainage area for a given antecedent soil moisture condition, and it ranges in value from 0 to 100. The SCS runoff curve numbers are grouped into three antecedent soil moisture conditions -- AMC I, AMC II, and AMC III. Values of runoff curve numbers for all three conditions may be computed following guidelines in the SCS National Engineering Handbook (USDA, 1972). AMC I is the dry soil condition, and AMC III is the wet condition. AMC II is normally considered to be the average antecedent moisture condition. However, studies of hydrologic data indicate that antecedent moisture condition II is not the average throughout Texas (USDA, May 5, 1978). Instead, investigations have shown that the average condition ranges from AMC I in west Texas to between AMC II and AMC III in east Texas. For the Longview Study Area, a correction to the AMC II condition curve number should be made in order to obtain a better estimate of the runoff curve number under average soil moisture conditions. The following equation applies for the vicinity of the project (USDA, May 5, 1978):

$$CN = CNII + 0.2 (CNIII - CNII) \quad (1)$$

where CN is the computed runoff curve number for average soil moisture conditions, CNII is the runoff curve number for AMC II, and CNIII is the runoff curve number for AMC III. This adjustment does not apply when the AMC II runoff curve number is less than 60.

Rarely is a watershed composed of both homogeneous land cover and soils of the same hydrologic soil group. It is therefore necessary to integrate the soils data with the land use information to arrive at a value of the runoff curve number for the watershed or subarea. Accordingly the following data on land use, soil type and corresponding curve number, representative of the Longview area, were composed.

A2.2.2 Hydrologic Classification of Soils

The general soils maps for Gregg and Upshur Counties (combined) and Harrison County (USDA, 1983) and (USDA, 1974) are the most current information available on the soils within the watersheds encompassing the Longview study area. The soil series delineated on these maps are the dominant series for each delineation, although smaller areas of other soil types may occur.

Soils are divided into four Hydrologic Groups by the SCS (USDA, 1972) based on runoff potential. These groups are A, B, C, and D. They vary from a low runoff potential found in Group A to a high runoff potential for Group D soils. The following condition II curve numbers were selected for use in the Longview study:

<u>Symbol</u>	<u>Land Type Description</u>	<u>Condition II Curve Number</u>			
		<u>A</u>	<u>B</u>	<u>C</u>	<u>D</u>
SFR	Single Family ¹	61	75	83	87
MF, MH	Multi Family Mobil Home	77	85	90	92
C, PU	Commercial Public Use	89	92	94	95
UNDEV	Undeveloped ²	43	65	76	82
I	Industrial	81	88	91	93
P	Parkland ³	49	69	79	84

1. Assumes 1/4 acre lots (35% to 40% average impervious cover).
2. CN's assume areas with 50% woods and 50% grass pasture in fair condition.
3. Assumes cover in fair condition (grass cover over 50% to 75%).

That portion of the study area within Gregg County is predominantly in two soil associations: Bowie - Cuthbert - Kirvin and Mantachies - Iuka. The Mantachie - Iuka unit is associated with floodplains and both soils in the unit are in Hydrologic Group C. The Bowie -

ESPEY, HUSTON & ASSOCIATES, INC.

Cuthbert - Kirvin unit is associated with uplands and is comprised of a mix of soils in Hydrologic Groups B and C; approximately 42% B and 58% C. The following weighted AMC condition II curve numbers were applied for the Bowie - Cuthbert - Kirvin soils unit:

<u>Symbol</u>	<u>Land Use</u>	<u>Condition II Curve Number</u>
SFR	Single Family	79.6
MF, MH	Multi Family Mobile Home	87.9
C, PU	Commercial Public Use	93.2
UNDEV	Undeveloped	71.4
I	Industrial	89.7
P	Parkland	74.8

Watersheds on the east side of Longview in Harrison County are primarily comprised of the Kirvin - Bowie association consisting of about 38% Kirvin soil in Hydrologic Group C, 32% Bowie soils in Group B and 30% other soils. The following weighted Condition II curve numbers were applied for the Kirvin - Bowie association:

<u>Symbol</u>	<u>Land Use Description</u>	<u>Condition II Curve Number</u>
SFR	Single Family	79.3
MF, MH	Multi Family Mobile Home	87.7
C, PU	Commercial Public Use	93.1
UNDEV	Undeveloped	70.9
I	Industrial	89.6
P	Parkland	74.4

A2.2.3 Land Use

Delineation of definitive land uses permits estimation of impervious cover for existing as well as future watershed development. Estimated percent impervious cover for various types of residential development corresponding to mean dwelling units per acre have been developed by the U.S. Department of Agriculture (USDA, 1975 and USDA, 1986). Typical values for residential development as well as commercial, industrial and public land uses are tabulated below.

<u>Land Use</u>	<u>Impervious Area</u>
Residential districts by average lot size	
1/8 acre or less (town houses)	65%
1/4 acre	38%
1/3 acre	30%
1/2 acre	25%
2 acres	12%
Commercial and Business	80%
Industrial Use	72%
Public Use	85%
Park	25%
Undeveloped, with roads	8%

Note: Includes streets, sidewalks, and all man-made impervious cover.

Existing Land Use

A comprehensive land use plan was updated by the Longview City Council in February 1985 (City of Longview, 1985). This plan provides data and maps of existing land use (1985) and projected future land use to the year 2000.

The comprehensive plan delineates existing and future land use categories as follows. (Estimates of impervious cover for each land use category were developed from the previous table).

Existing Land Use (1985):

<u>Symbol</u>	<u>Land Use</u>	<u>Impervious Area</u>
SFR	Single Family	35%
MF	Multi Family	65%
MH	Mobile Home	65%
C	Commercial	72%
I	Industrial	72%
PU	Public Use	85%
P	Parks	25%

Future Land Use

For the purpose of watershed modeling and for defining the hydrologic response of future land use conditions in the Longview study area, a set of SCS curve numbers for the hydrologic soil groups A, B, C, and D were selected which translate to a Rational Method runoff coefficient "C" corresponding to a residential development density of 5 units per 1 acre (SF-4 zoning). This was done since it is the City's goal to accommodate peak runoff rates in Master Drainage Plan improvements that could be expected from a SF-4 level of development.

Values of Rational Method runoff coefficients versus residential density (units/acre) for a 100-year return period storm event are presented in Table 4-1 of the proposed City of Longview Drainage Criteria Manual. The values of "C" shown in Table 4-1 of the manual were plotted against units per acre (Figure A-1). A runoff coefficient of $C = 0.70$ corresponding to 5 units per 1 acre was indicated by the resulting curve.

The impervious cover associated with each residential density presented in Table 4-1 of the manual was also plotted against the corresponding units per acre. The resulting impervious cover related to a density of 5 units per 1 acre is 48 percent as indicated by the curve (Figure A-2).

A-7

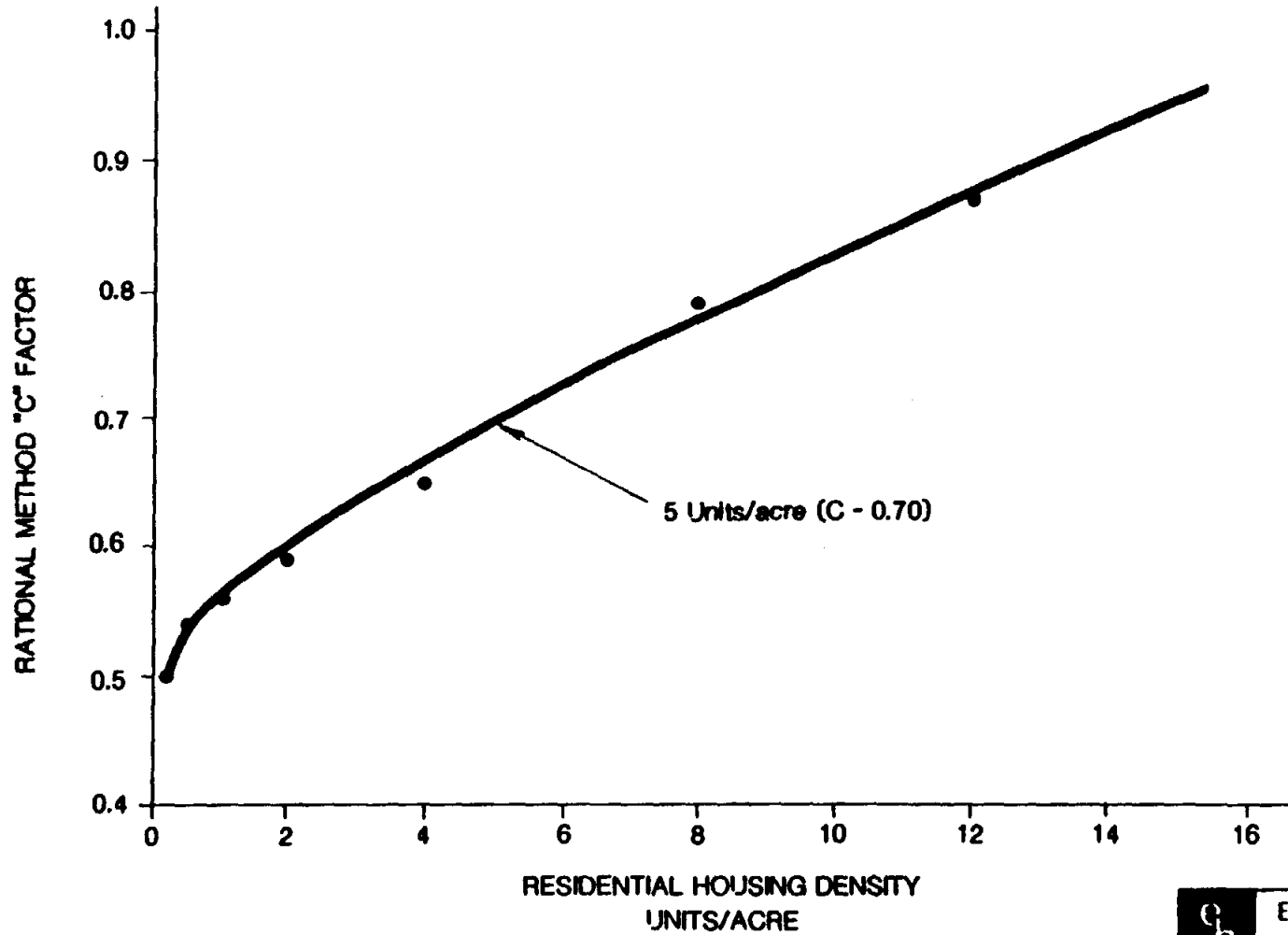

	ESPEY, HUSTON & ASSOCIATES, INC. Engineering & Environmental Consultants
	FIGURE A-1 RATIONAL "C" VS. RESIDENTIAL HOUSING DENSITY FOR 100-YEAR EVENT

A-8

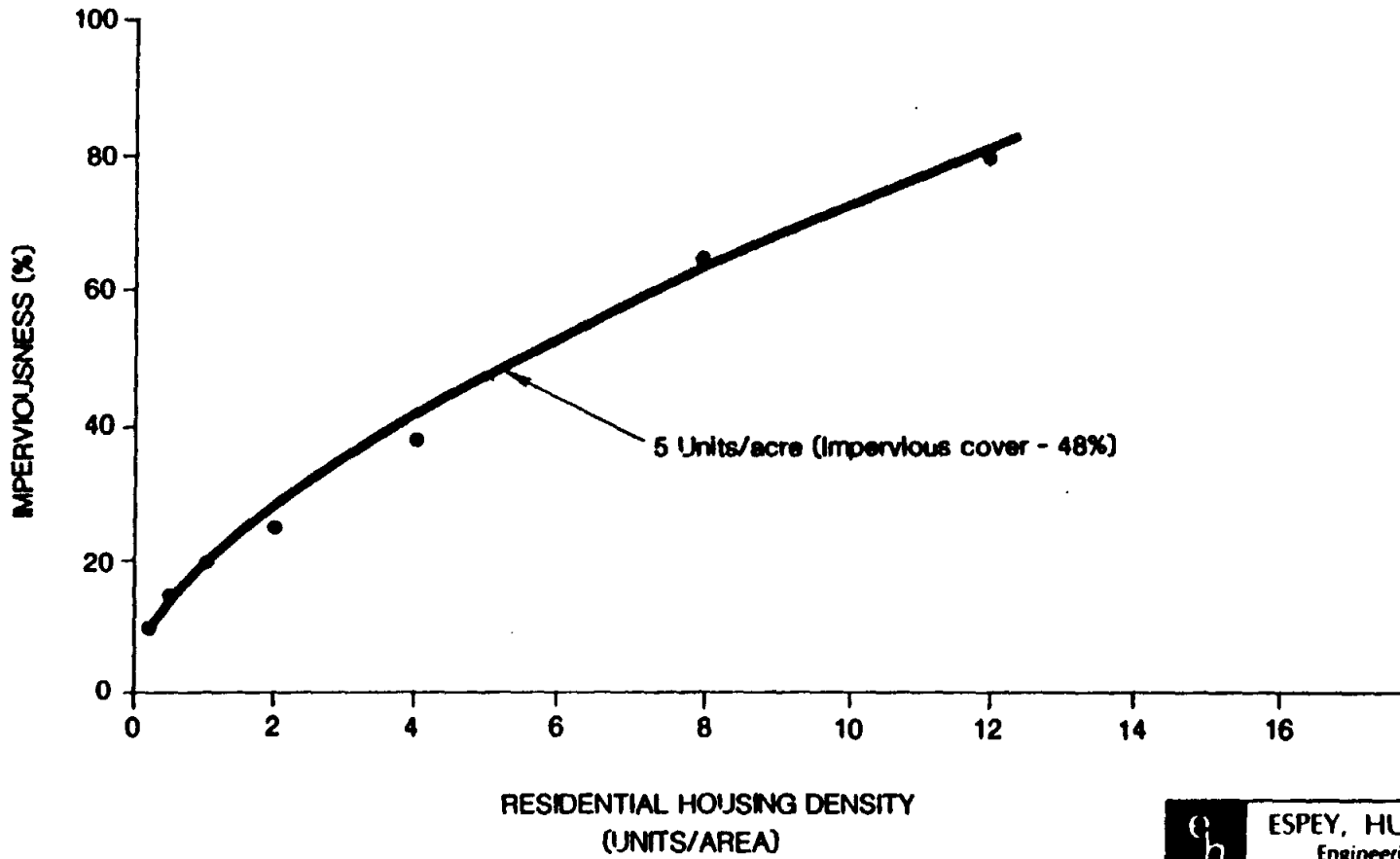

eh ESPEY, HUSTON & ASSOCIATES, INC.
Engineering & Environmental Consultants

FIGURE A-2
IMPERVIOUSNESS VS.
RESIDENTIAL HOUSING DENSITY

In the application of the SCS methodology (TR-55) the average percent impervious area is used to develop composite values of curve number. The assumption used in developing the curve numbers presented in Table 2-2a in TR-55 are: impervious areas are directly connected to the drainage system, impervious areas have a curve number of 98, and pervious areas are considered to be equivalent to open space in good hydrologic condition. Figure 2-3 on TR-55 allows for the estimation of curve numbers for other combinations of land use conditions. The urban curve numbers in TR-55 Table 2-2a are assumed typical land use relationships.

Assuming all the impervious area is directly connected to the drainage system, and pervious areas are equivalent to open space or pasture in good hydrologic condition TR-55 figure 2-3 was used to estimate composite curve numbers for a density of 5 units per acre.

Cover Type	Curve Number for Hydrologic Soil Group			
Land Use	A	B	C	D
Open Space				
Good Condition (grass cover > 75%)	39	61	74	80
5 units per acre (48% impervious area)	68	79	86	89

A2.2.4 Integrating Soils Type and Land Use

Runoff curve numbers for the sub-watersheds in the study area were calculated for AMC II following the standard SCS procedure (USDA, 1972), and the average condition curve number was determined from Equation 1.

Successful integration of soils and land use proceeds with the subdivision of the study area watersheds. In order to evaluate future structural improvements to the drainage conveyance system the criteria for subdivision is based on the delineation of the watershed to a 100 acre size as the smallest division.

The land use and general soils maps were enlarged and overlain on the USGS topographic base. The percentage of the total sub-watershed area within each land use and soil classification grouping was measured and tabulated as illustrated in Table 1. The calculations for weighing each land use and soil type to arrive at a composite curve number (CN) are self explanatory. The average curve number computed for the sub-watershed is input to the HEC-1 computer model. Tables A-1, A-3, A-5, A-7, A-9, and A-11 present the curve number computation procedure and results for the Grace Creek, Hawkins, Eastman Lake and Iron Bridge Creek watersheds.

Table 1
Example Watershed Computation
of Average Curve Number

(1) Sub Area	(2) Total Area (ac.)	(3) General Soil Unit	(4) Land Use	(5) % Total Area	(6) AMC II Curve Number	(7) Composite Curve Number AMC II	(8) Curve Number AMC III	(9) Average Curve Number
A	100	BCK	SFR	10	79.6	78.4	90	80.7
		BCK	UNDEV	20	71.4			
		MI	SFR	30	83			
		MI	MF,MH	10	90			
		MI	UNDEV	30	76			

Col. 1: Subarea designation

Col. 2: Total area within subarea A.

Col. 3: BCK - Bowie-Cuthbert-Kirvin soil association
MI - Mantachie-Iuka soil association

Col. 4: Land use in each soil association

Col. 5: Percent of the total subarea within each land use, within each soil association, within subarea A.

Col. 6: Condition II Curve Number from tables developed for the BCK and MI soil association.

Col. 7: Composite Condition II Curve Number:
 $10\% (79.6) + 20\% (71.4) + 30\% (83) + 10\% (90) + 30\% (76) = 78.4$

Col. 8: Condition III Curve Number from SCS NEH 4.

Col. 9: Average Curve Number:
 $CN = CNII + 0.2 (CNIII - CNII)$

A2.2.5 Time of Concentration

The calculation of time of travel (Tt), the time from one point to another in the study area watersheds, follows the methodology presented in TR-55 (USDA, 1986). Time of

concentration (Tc) is the time for runoff to travel from the most distant point (in time) in the watershed or subarea to the subarea or watershed outlet. Tc is computed by summing all travel times for consecutive components of the drainage conveyance system.

The SCS methodology recognizes three components of the drainage conveyance system: sheet flow, shallow concentrated flow and open channel flow. Travel time (Tt) is computed by the relationship.

$$T_t = \frac{L}{3600V} \quad (2)$$

where: L = flow length (ft), and
 V = average velocity (ft/sec)
 Tt = travel time (hours)

The travel time for sheet flow is calculated by Manning's kinematic solution:

$$T = \frac{0.007 (nL)^{0.8}}{(P_2)^{0.5} S^{0.4}} \quad (3)$$

where: n = Manning's roughness coefficient,
 L = flow length (ft),
 P₂ = 2-year, 24-hour rainfall (in), and
 S = slope of hydraulic grade line (landslope; ft/ft)

Sheet flow should not exceed 300 feet and, in urbanized areas, a great deal of judgement is required to select the appropriate length that properly models the land use and hydraulics of the system. In single family residential areas, a length of 110-120 feet is probably representative of the sheet flow distance. In the central business district or other business districts, the flow length may be as long as 300 feet, but the flow is over a paved surface such as a driveway, parking lot or alleyway. The appropriate "n" value should be selected for the surface described from the list presented in Table 3-1 in TR-55 (USDA, 1986).

The SCS methodology assumes the flow becomes concentrated after a maximum of 300 feet. In rural areas, shallow concentrated flow occurs in swales and shallow depressions. In urban areas, the concentrated flow is that flow in the paved gutters of the street prior to the first inlet. Figure 3-1 in TR-55 (USDA, 1986) presents average velocities for estimating travel time for shallow concentrated flow for both paved and unpaved surfaces.

The third component of the drainage conveyance system is the channelized flow path. In the channelized component of the travel time, the flow velocity was determined for bank-full stage using Mannings's equation or hydraulic information from a water surface profile computation. In urban watersheds, storm sewers will generally carry only a portion of a less frequent storm event. The proposed Drainage Criteria Manual or standard handbooks of hydraulics should be consulted to determine the average velocity in pipes for either pressure or nonpressure flow.

Smaller time increments for a particular range of T_c above are permitted. The maximum value of the time increment should not be greater than $0.172 T_c$. Because of the varying range of times of concentration computed for the sub-watersheds, the need to model areas as small as 100 acres, and since the HEC-1 model allows only one time increment for all sub-watersheds for a particular watershed model, a small time increment of 2 minutes was specified for our analysis. In the HEC-1 models for the Grace and Hawkins Creek watersheds, a model time increment or time interval of 2 minutes was used successfully with a 12-hour total design storm duration to compute runoff through each of the watershed drainage systems.

In hydrograph analysis, watershed lag (or lag time) is defined as the time from the center of mass of excess rainfall to the peak rate of runoff. Analysis of historical storm event flood hydrographs is one method for determining the lag of a watershed. However, there is inadequate data for such an analysis in Longview. Studies of many storm events over a range of watershed conditions have resulted in an empirical relationship between lag and time of concentration:

$$\text{LAG}(T_p) = 0.6 T_c \quad (4)$$

ESPEY, HUSTON & ASSOCIATES, INC.

This relationship was originally intended for undeveloped watersheds and for a nearly uniform distribution of runoff. However, studies of urban hydrographs have shown that this relationship is also applicable in urban watersheds.

The calculation of T_c and the selection of time increments are critical in the runoff modeling process. Poor selections may result in considerable (cumulative) error. Time increments for the hydrograph computations are suggested by the SCS (USDA, July 1978) and are as follows:

<u>T_c, hrs</u>	<u>Time Increment, hrs</u>
0.3 to 0.6	0.05
0.6 to 0.9	0.10
0.9 to 1.2	0.15
1.2 to 1.5	0.20
1.5+	0.25

To define existing conditions watershed Lag(T_p), the watershed physical data for the travel time calculations for the study area watersheds were taken from the U.S. Geological Survey 7.5-minute topographical maps of the study area. The computations of existing and future projected watershed conditions for travel time, time of concentration and watershed Lag for the Grace, Hawkins, Eastman Lake and Iron Bridge Creek watersheds are tabulated in Tables A-2, A-4, A-6, A-8, A-10 and A-12 given at the end of this appendix. For the Grace and Hawkins Creek watersheds, Future condition watershed Lag (T_p) was estimated by comparing certain existing urbanized versus rural Lag values, the assumption being that the existing urbanized areas would be representative of future urbanization throughout the watershed. For the Eastman Lake and Iron Bridge Creek watersheds, estimates of subarea flow times were made for projected urban conditions and converted to Lag times.

For the Grace and Hawkins Creek Watershed Lag time computations, both rural and urban watersheds of similar size were selected at random and their respective Lag times were compared by plotting the rural values against the urban values. As expected, a line fitted through

the points indicated the urban values are shorter in time where streets, gutters, or sewers provide a more efficient flow pattern than pervious areas. The resulting relationship suggests the urban lag values to be about 77 percent of the rural values. In the model, all subarea rural Lag values were multiplied by 0.77 to obtain values for future urban conditions.

A2.3 HYPOTHETICAL STORM EVENTS

The National Weather Service's (NWS) Rainfall Frequency Atlas of the United States (Hershfield, 1961) and Technical Memorandum NWS HYDRO-35 (Frederick, et. al., 1977) were used to obtain the point rainfall values corresponding to storms of different durations and frequencies for the Longview area as shown in Table A-1a.

A2.3.1 Rainfall Distributions

Utilizing the HEC-1 computer model (USCE, 1981), synthetic design storms were generated based on given depth-duration data.

Depths for 5- and 15-minute durations were interpolated from 5- and 15-minute, 2- and 100-year depths using the following equations from HYDRO-35 (Frederick, et. al., 1977):

$$D_5 = 0.278 (D_{100}) + 0.674 (D_2)$$

$$D_{10} = 0.449 (D_{100}) + 0.496 (D_2)$$

$$D_{25} = 0.669 (D_{100}) + 0.293 (D_2)$$

where D_n is the precipitation depth for n-minute duration.

In developing hypothetical storm events for modeling purposes, cumulative precipitation for each time interval is computed by log-log interpolation of depths from the depth-duration data. For the design storms, incremental precipitation was then computed and rearranged so the second largest value precedes the largest value, the third largest value follows the largest value, the fourth largest precedes the second largest, etc. In this manner, design storm rainfall

TABLE A-1a
 HYPOTHETICAL STORM EVENTS
 DEPTH - DURATION - FREQUENCY
 LONGVIEW, TEXAS

Duration	Frequency (yrs)						
	2	5	10	25	50	100	500 ²
5 min ¹	0.52	0.63	0.64	0.72	0.80	0.85	1.00
15 min ¹	1.10	1.27	1.39	1.59	1.74	1.89	2.22
60 min ¹	1.95	2.41	2.74	3.21	3.58	3.95	4.75
2 hr	2.50	3.25	3.75	4.35	4.80	5.30	6.70
3 hr	2.75	3.50	4.15	4.75	5.25	5.95	7.80
6 hr	3.30	4.30	5.00	5.90	6.55	7.30	9.00
12 hr	3.85	5.10	6.15	7.00	7.90	8.95	10.70
24 hr	4.50	6.00	7.00	8.15	9.15	10.20	13.15

¹ Depth for 5-, 15-, and 60-minute durations, 5-, 10- and 25-year frequencies are interpolated from 5-, 15-, and 60-minute, 2- and 100-year depths using the following equations from HYDRO-35 (Frederick, et. al., 1977):

$$D_5 = 0.278 (D_{100}) + 0.674 (D_2)$$

$$D_{10} = 0.449 (D_{100}) + 0.496 (D_2)$$

$$D_{25} = 0.669 (D_{100}) + 0.293 (D_2)$$

² Depth for 5-minute through 24-hour durations, 500-year frequency are extrapolated from a plot of the 2-year through 100-year frequencies.

intensities will begin low, increase to a maximum near the middle of the storm duration and decrease until the storm's end.

A2.3.2 Depth-Area Relationship Simulation

The depth-area routine in the HEC-1 computer program was used to maintain consistency between successive downstream hydrographs. In using the depth-area routine in the HEC-1 computer program, the precipitation is distributed throughout the watershed in such a way that the runoff generated by each subarea within the watershed is consistent with the runoff contributed by other subareas. Each subarea hydrograph is generated from rainfall quantities that correspond to a specific subarea size and a specific precipitation depth drainage area relationship.

HEC-1 generates a number of "index hydrographs" computed from a set of precipitation depth-drainage area values reflecting the decreasing average depth of precipitation (for a given storm frequency) as the size of the contributing drainage area increases. This allows the successive recomputation of decreasing consistent flood volumes contributed at successive downstream points.

HEC-1 applies an interpolation formula to the ordinates of the two index hydrographs bracketing the tributary drainage area size. The interpolation formula assumes a linear discharge log drainage area relationship as follows:

$$Q = Q_1 \times \left(\frac{\text{Log } A_2}{\text{Log } A_x} \right) + \left(Q_2 \times \frac{\text{Log } A_x}{\text{Log } A_1} \right)$$

- Where:
- Q is the instantaneous flow of the consistent hydrograph;
 - A_x is the tributary drainage area;
 - A₁ is the next smaller index area;
 - A₂ is the next larger index area;
 - Q₁ is the instantaneous flow for index hydrograph 1; and,
 - Q₂ is the instantaneous flow for index hydrograph 2.

HEC-1 will generate a set of hydrographs and select the appropriate hydrograph at all downstream locations that are in conformance with the precipitation depth drainage area function provided.

A2.4 DIMENSIONLESS UNIT HYDROGRAPH

A unit hydrograph is a hydrograph of runoff resulting from a unit of rainfall excess occurring at a uniform rate, uniformly distributed over a watershed in a specified duration of time (Haan and Barfield, 1978). A unit hydrograph may be developed for any watershed from observed rainfall and streamflow records. However, a unit hydrograph developed for a particular watershed from one storm may vary greatly from a unit hydrograph developed over the same watershed with a different storm, due to differences in spacial and temporal distribution of the storm (Meier, 1964). Also, the differences in generated unit hydrographs may result from differences in durations of rainfall excess. Conceptually, an infinite number of unit hydrographs can be developed for any particular watershed (Haan and Barfield, 1978). Additionally, the shape of the watershed affects the shape of the unit hydrograph (USDA, 1972). Therefore, an average dimensionless unit hydrograph is often chosen for small watersheds with insufficient rainfall and streamflow data.

The dimensionless unit hydrograph used by the SCS was developed by Victor Mockus (USDA, 1972). This unit hydrograph was derived from a large number of natural unit hydrographs from watersheds varying in size and geographical locations and is supplied with the HEC-1 model. The HEC-1 model allows only one dimensionless unit hydrograph to represent all sub-watersheds in the watershed model. Since the sub-watersheds in this study vary in shape and size, the use of an average dimensionless unit hydrograph is therefore necessary.

Meier (1964) compared average dimensionless unit hydrographs from three small watersheds in Texas to the dimensionless unit hydrograph derived by Mockus. This comparison established that only minor differences occur in the dimensionless graphs. Therefore, Mockus' dimensionless unit hydrograph was assumed to represent an average dimensionless unit hydrograph for the sub-watersheds studied.

A2.5 STREAM ROUTINGS

Two procedures were used for routing hydrographs through stream reaches in the Longview study area. The Muskingum method was used where the storage versus outflow relationship for the stream routing reach was not known. In stream routing reaches where a storage versus outflow relationship was available, the modified PULS method was used.

Muskingum Method:

The Muskingum routing method assumes the total flood storage in a stream reach is equal to prism plus wedge storage. The prism storage is computed as the routing coefficient K times the outflow. The wedge storage is computed as K times the coefficient, X , and the difference between inflow and outflow. The coefficient K has units of time and corresponds to the travel time of the flood wave through the stream reach. The constant X is dimensionless varying between $X=0$ and $X=0.5$. In the case where K is equal to the routing time interval, and an X value of 0.5 is used, a routed hydrograph is translated through the stream reach without change in shape. An efficient channel that confines all of a routed hydrograph would have an X value of 0.5. An X value of zero produces maximum attenuation similar to a reservoir storage routing.

The Muskingum routing coefficients for streams in the Longview area were determined in the following manner. The coefficient K was computed as the travel time through the stream reach length (L) assuming an average flood wave velocity (v); $K=L/v$. In the Grace Creek watershed where HEC-2 models were available on stream reaches, the average flood wave velocity values reflected for the study were verified from the computation of the travel time between successive watershed nodes as represented by the accumulated travel time between cross sections in the HEC-2 models. In most rural Grace Creek streams with relatively mild slopes, a value of 2 ft/sec was specified for the average flood wave velocity. Where HEC-2 models were available this velocity was confirmed or adjusted to match the HEC-2 travel time velocity which approached 4-5 ft/sec in some urban reaches.

HEC-2 models were not available for streams in the Hawkins Creek watershed. The Muskingum routing values selected for rural areas were based on experience in Grace Creek. The average flood wave velocity specified in the existing condition HEC-1 model for the calculation of the Muskingum K value was 2 ft/sec. In the future condition model the average flood wave velocity was increased to 4 ft/sec on the tributaries to the east side of Hawkins Creek, and 3 ft/sec for the reaches of the main stream of Hawkins Creek. These values assume some future channel improvements can be anticipated. Tributaries west of the creek lie outside of the Longview city limits and were, therefore, not changed from existing conditions.

In the existing condition Grace Creek HEC-1 model, the Muskingum factor (X) was selected as $X=0.0$ for Muskingum routing reaches in rural areas and $X=0.2$ in urban areas. In the future condition model (not including any Master Plan improvements), these values were adjusted to $X=0.3$ in rural areas to reflect a typical degree of future channelization and channel overbank encroachment typical of urban areas, but remain at $X=0.2$ in existing urban areas. In urban areas the assumption is that the current drainage systems cannot handle large flows without considerable overbank flooding (and resulting storage).

In Hawkins Creek a more conservative approach was taken in the consideration of channel storage to be lost due to urban development and possible channel and/or floodplain modifications. In tributary stream reaches east of Hawkins Creek (within the Longview city limits), a Muskingum factor was selected as $X=0.2$. On the main stream of Hawkins Creek this value was selected as $X=0.15$. Since the City of Longview does not prohibit development within the 100-year floodplain, these values reflect some level of channel and/or floodplain modification in the future, but not extensive rectification.

An analysis of the sensitivity of varying the Muskingum factor (X) indicated an average 2 percent increase in the routed peak flow rate using the value of $X=0.2$ compared to $X=0$. The timing of the peak is essentially unaffected.

Modified Puls Method:

In stream reaches where detailed steady-flow water surface profiles are available, for example from the Federal Emergency Management Agency (FEMA) Flood Insurance Study for the City of Longview, modified PULS stream routing was used. In this method, a hydrograph at an upstream location is routed to a downstream location defining the storage in the reach as the volume in the channel under the water surface profile, and the outflow is the discharge in the channel at the downstream end of the reach.

The modified PULS routing was accomplished by providing the storage versus outflow relationship as direct input to the HEC-1 model. Steady-flow water surface profiles, computed over a range of discharges in the HEC-2 models, were used to determine storage-outflow relationships in the stream reaches.

Routing Steps (NSTPS):

The determination of the number of routing steps is identical in the Muskingum and modified PULS methods. Ideally, the number of steps or reach lengths should be determined by calibration, optimizing the number of steps to replicate an observed hydrograph. In the absence of observed flood hydrographs, an estimate of this parameter, represented by the variable NSTPS in HEC-1, is derived by dividing the total travel time (K) for the reach by the model time interval. The time interval is selected to insure a sufficient number of points to define the rising limb of the flood hydrograph.

APPENDIX A

REFERENCES

- City of Longview. Comprehensive Plan Update 1985-2000, Longview, Texas, February 12, 1985.
- Federal Emergency Management Agency. "Flood Insurance Study, City of Longview. Texas Gregg and Harrison Counties, Washington, D.C. January 17, 1990.
- Hershfield, D.M., 1961: "Rainfall Frequency Atlas of the United States for Durations from 30 Minutes to 24 Hours and Return Periods from 1 to 100 Years", TECHNICAL PAPER No. 40, Weather Bureau, U.S. Department of Commerce, Washington, D.C., 115 pp.
- Meier, Wilbur L., Jr. 1964. Analysis of unit hydrographs for small watersheds in Texas. Bull. 6414. Texas Water Commission. Austin, Texas.
- National Weather Service. 1977. Five to 60 minute Precipitation Frequency for the Eastern and Central United States, Technical Memorandum NWS Hydro-35.
- _____. 1956. (Weather Bureau) Hydrometeorological Report No. 33, Seasonal Variation of the Probable Maximum Precipitation East of the 105th Meridian for Areas from 10 to 1,000 square miles and Durations of 6, 12, 24, 48 hours. Washington, D.C., April 1956.
- U.S. Army Corps of Engineers. 1973. HEC-2, Water Surface Profiles, Generalized Computer Program, The Hydrologic Engineering Center, Davis, California.
- _____. 1978. Flood Hydrograph Package (HEC-1) User Manual for Dam Safety Investigations, The Hydrologic Engineering Center, Davis, California.
- _____. 1973. HEC-1, Flood Hydrograph Package, Generalized Computer Program, The Hydrologic Engineering Center, Davis, California.
- _____. 1981. HEC-1, Flood Hydrograph Package, Generalized Computer Program, (revised), The Hydrologic Engineering Center, Davis, California.
- U.S. Department of Agriculture. January 1955. Urban Hydrology for small watersheds. Technical release No. 55. Soil Conservation Service. Washington, D.C.
- _____. 1972. Soil Conservation Service national engineering handbook, Section 4, Hydrology. Washington, D.C.
- _____. January 1975. Urban hydrology for small watersheds. Technical Release No. 55, Soil Conservation Service. Washington, D.C.
- _____. May 1983. Soil Survey of Upshur and Gregg Counties, Texas. U.S. Department of Agriculture. Soil Conservation Service. Temple, Texas

ESPEY, HUSTON & ASSOCIATES, INC.

Frederick, R.H., et. al., 1977. "Five-To-Sixty Minute Precipitation Frequency for the Eastern and Central United States", NOAA Technical Memorandum HYDRO-35, National Weather Service, U.S. Department of Commerce, Washington, D.C., 37 pp.

U.S. Army Corps of Engineers, 1981. "HEC-1 Flood Hydrograph Package, the Hydrologic Engineering Center, Davis, California, (Revised 1985).

TABLE A-1

SUBAREA AVERAGE SCS RUNOFF CURVE NUMBERS FOR EXISTING AND FUTURE CONDITIONS
GRACE CREEK WATERSHED

Sub-Area ¹	Total Area (sq mi)	General ² Soil Unit	Land ³ Use	EXISTING					FUTURE			
				% Total Area	Curve ⁴ Number	Composite Curve Number Cond. II	Composite Curve Number Cond. III	Average ⁵ Curve Number	Curve ⁶ Number	Composite Curve Number Cond. II	Composite Curve Number Cond. III	Average ⁵ Curve Number
GR-1A	1.05	BCK	UNDEV	100	71.4	71.4	86.0	74.3	83.1	83.1	93.0	85.1
GR-1B	0.96	BCK	UNDEV	100	71.4	71.4	86.0	74.3	83.1	83.1	93.0	85.1
GR-1C	2.27	BCK	UNDEV	100	71.4	71.4	86.0	74.3	83.1	83.1	93.0	85.1
GR-1D	0.98	BCK	SFR	1	79.6	71.6	86.0	74.5	83.1	83.1	93.0	85.1
			MF, MH	1	87.2	---	---	---	87.9			
			UNDEV	98	71.4	---	---	---	83.1			
GR-1E	2.02	BCK	SFR	8	79.6	73.4	87.5	76.2	83.1	83.3	93.0	85.2
			MF, MH	4	87.9	---	---	---	87.9			
			UNDEV	88	71.4	---	---	---	83.1			
GR-1F	1.11	MI	UNDEV	32	76.0	73.2	87.3	76.0	86.0	84.0	93.0	85.8
		BCK	UNDEV	68	71.4	---	---	---	83.1			
GR-1G	1.33	BCK	UNDEV	100	71.4	71.4	86.0	74.3	83.1	83.1	93.0	85.1
GR-1H	1.48	BCK	UNDEV	97	71.4	71.5	86.0	74.4	86.0	85.9	94.0	87.1
		MI	UNDEV	3	76.0	---	---	---	83.1			
GR-1I	1.70	MI	UNDEV	59	76.0	75.1	88.1	77.7	86.0			86.7
		MI	SFR	2	83.0	---	---	---	86.0			
		BCK	UNDEV	30	71.4	---	---	---	83.1			
		BCK	SFR	9	79.6	---	---	---	83.1			
GR-1J	1.63	BCK	SFR	10	79.6	75.3	88.3	77.9	83.1	84.5	93.5	86.3
			C, PU	14	93.2	---	---	---	93.2			
			UNDEV	76	71.4	---	---	---	83.1			
GR-1K	1.32	MI	UNDEV	16	76.0	77.4	89.4	79.8	86.0	86.0	94.0	87.6
		BCK	UNDEV	60	71.4	---	---	---	83.1			
		BCK	C, PU	24	93.2	---	---	---	93.2			
GR-1L	1.71	MI	UNDEV	47	76.0	74.8	88.0	77.4	86.0	84.5	93.5	86.3
		BCK	UNDEV	43	71.4	---	---	---	83.1			
		BCK	C, PU	9	93.2	---	---	---	93.2			

A-23

TABLE A-1 (Cont'd)

Sub-Area ¹	EXISTING								FUTURE			
	Total Area (sq mi)	General ² Soil Unit	Land ³ Use	% Total Area	Curve ⁴ Number	Composite Curve Number Cond. II	Composite Curve Number Cond. III	Average ⁵ Curve Number	Curve ⁶ Number	Composite Curve Number Cond. II	Composite Curve Number Cond. III	Average ⁵ Curve Number
GRTA	1.61	BCK	UNDEV	100	71.4	71.4	86.0	74.3	83.1	83.1	93.0	85.1
GRTB	1.28	BCK	UNDEV	100	71.4	71.4	86.0	74.3	83.1	83.1	93.0	85.1
GRTC	0.71	BCK	UNDEV	100	71.4	71.4	86.0	74.3	83.1	83.1	93.0	85.1
GRTD	1.74	BCK	UNDEV	100	71.4	71.4	86.0	74.3	83.1	83.1	93.0	85.1
GRTE	0.98	BCK	SFR	9	79.6	72.3	86.0	75.0	83.1	83.1	93.0	85.1
			MF, MH	1	87.9	---	---	---	87.9			
			UNDEV	90	71.4	---	---	---	83.1			
GRTF	1.97	BCK	SFR	0	79.6	76.0	89.0	78.6	83.1	83.1	93	85.1
			MF, MH	0	87.9	---	---	---	87.9			
			UNDEV	100	71.4	---	---	---	83.1			
GRTG	1.08	BCK	SFR	12	79.6	74.0	88.0	76.8	83.1	83.5	93.0	85.4
			MF, MH	5	87.9	---	---	---	87.9			
			UNDEV	49	71.4	---	---	---	83.1			
			MI	33	76.0	---	---	---	86.0			
GR-2A	1.98	BCK	UNDEV	38	71.4	74.5	88.0	77.2	83.1	84.9	93.9	86.7
			MI	59	76.0	---	---	---	86.0			
			MI	3	83.0	---	---	---	86.0			
GR-2B	1.74	BCK	UNDEV	77	71.4	72.9	86.9	75.7	83.1	83.4	93.0	85.3
			MI	11	76.0	---	---	---	86.0			
			BCK	12	79.6	---	---	---	83.1			
GR-2C	2.84	BCK	SFR	1	79.6	72.7	86.2	78.2	83.1	83.4	93.0	85.3
			MI	1	83.0	---	---	---	86.0			
			UNDEV	57	71.4	---	---	---	83.1			
			MI	40	76.0	---	---	---	86.0			
GR-2D	2.15	BCK	UNDEV	40	71.4	75.0	88.0	77.6	83.1	85.7	94.0	87.4
			MI	59	76.0	---	---	---	86.0			
			BCK	1	79.6	---	---	---	83.1			
			MI	1	83.0	---	---	---	86.0			

A-24

TABLE A-1 (Cont'd)

Sub-Area ¹	EXISTING								FUTURE			
	Total Area (sq mi)	General ² Soil Unit	Land ³ Use	% Total Area	Curve ⁴ Number	Composite Curve Number Cond. II	Composite Curve Number Cond. III	Average ⁵ Curve Number	Curve ⁶ Number	Composite Curve Number Cond. II	Composite Curve Number Cond. III	Average ⁵ Curve Number
GR-2E	2.31	MI	P	10	79.0	74.7	88.0	77.4	86.0	84.9	93.9	86.7
		BCK	P	3	74.8	---	---	---	83.1			
		MI	UNDEV	54	76.0	---	---	---	86.0			
		BCK	UNDEV	33	71.4	---	---	---	83.1			
RAY-1A	1.55	BCK	UNDEV	100	71.4	71.4	86.0	74.3	83.1	83.1	93.0	85.1
RAY-1B	2.84	BCK	UNDEV	100	71.4	71.4	86.0	74.3	83.1	83.1	93.0	85.1
RAY-1C	1.37	BCK	UNDEV	100	71.4	71.4	86.0	74.3	83.1	83.1	93.0	85.1
RAY-1D	3.25	BCK	UNDEV	100	71.4	71.4	86.0	74.3	83.1	83.1	93.0	85.1
RAY-1E	2.42	BCK	UNDEV	100	71.4	71.4	86.0	74.3	83.1	83.1	93.0	85.1
RAY-1F	2.65	BCK	UNDEV	100	71.4	71.4	86.0	74.3	83.1	83.1	93.0	85.1
RAY-1G	3.10	BCK	SFR	5	79.6	71.8	86.0	74.6	83.1	83.1	93.0	85.1
			UNDEV	95	71.4	---	---	---				
ELM-1A	2.39	BCK	UNDEV	100	71.4	71.4	86.0	74.3	83.1	83.1	93.0	85.1
ELM-1B	1.36	BCK	UNDEV	100	71.4	71.4	86.0	74.3	83.1	83.1	93.0	85.1
ELM-1C	3.04	BCK	SFR	29	79.6	75.2	88.2	77.8	83.1	83.7	93.0	85.6
			MF, MH	2	87.9	---	---	---	87.9			
			C, PU	5	93.2	---	---	---	93.2			
			UNDEV	64	71.4	---	---	---	83.1			
RAY-2A	2.60	BCK	SFR	7	79.6	72.1	86.1	74.9	83.1	83.1	93.0	85.1
			MF, MH	1	87.9	---	---	---	87.9			
			UNDEV	92	71.4	---	---	---	83.1			
RAY-2B	1.47	BCK	UNDEV	100	71.4	71.4	86.0	74.3	83.1	83.1	93.0	85.1
RAY-2C	1.42	BCK	SFR	5	79.6	72.8	86.8	75.6	83.1	83.2	93.0	85.2
			UNDEV	75	71.4	---	---	---	83.1			
			I	2	89.7	---	---	---	89.7			
			P	18	74.8	---	---	---	83.1			
DR-2A	1.39	BCK	UNDEV	100	71.4	71.4	86.0	74.3	83.1	83.1	93.0	85.1

A-25

TABLE A-1 (Cont'd)

Sub-Area ¹	EXISTING								FUTURE			
	Total Area (sq mi)	General ² Soil Unit	Land ³ Use	% Total Area	Curve ⁴ Number	Composite Curve Number Cond. II	Composite Curve Number Cond. III	Average ⁵ Curve Number	Curve ⁶ Number	Composite Curve Number Cond. II	Composite Curve Number Cond. III	Average ⁵ Curve Number
DR-2B	1.92	BCK	UNDEV	100	71.4	71.4	86.0	74.3	83.1	83.1	93.0	85.1
DR-2C	1.77	BCK	SFR	5	79.6	71.3	86.0	74.2	83.1	83.2	93.0	85.2
			MF, MH	1	87.9	---	---	---	87.9			
			UNDEV	93	71.4	---	---	---	83.1			
DR-2D	1.64	BCK	SFR	13	79.6	72.5	86.5	75.3	83.1	83.1	93.0	85.1
			UNDEV	87	71.4	---	---	---				
DR-2E	1.22	BCK	SFR	17	79.6	72.3	86.3	75.1	83.1	83.3	93.0	85.2
			C, PU	1	93.2	---	---	---	93.2			
			UNDEV	81	71.4	---	---	---	83.1			
DR2TA	1.93	BCK	UNDEV	100	71.4	71.4	86.0	74.3	83.1	83.1	93.0	85.1
DR2TB	0.90	BCK	UNDEV	100	71.4	71.4	86.0	74.3	83.1	83.1	93.0	85.1
DR2TC	0.83	BCK	UNDEV	100	71.4	71.4	86.0	74.3	83.1	83.1	93.0	85.1
DR2TD	1.45	BCK	UNDEV	100	71.4	71.4	86.0	74.3	83.1	83.1	93.0	85.1
DR2TE	0.90	BCK	UNDEV	100	71.4	71.4	86.0	74.3	83.1	83.1	93.0	85.1
DR2TF	1.36	BCK	UNDEV	89	71.4	71.8	86.0	74.6	83.1	83.1	93.0	85.1
			P	11	74.8	---	---	---				
DR32TG	1.63	BCK	MF, MH	10	87.9	73.1	87.1	75.9	87.9	83.6	93.0	85.5
			UNDEV	90	71.4	---	---	---	83.1			
DR2TH	1.60	BCK	C, PU	9	93.2	73.4	87.4	76.2	93.2	84.0	93.0	85.8
			UNDEV	91	71.4	---	---	---	83.1			
DR2F	4.34	BCK	SFR	1	79.6	75.9	88.9	78.5	83.1	85.0	94.0	86.8
			MF, MH	13	87.9	---	---	---	87.9			
			C, PU	13	93.2	---	---	---	93.2			
			UNDEV	61	71.4	---	---	---	83.1			
			P	12	74.8	---	---	---	83.1			
SB-1A	1.27	BCK	SFR	15	79.6	77.4	89.4	79.8	83.1	85.3	94.0	87.0
			C, PU	22	93.2	---	---	---	93.2			
			UNDEV	63	71.4	---	---	---	83.1			

A-26

TABLE A-1 (Cont'd)

Sub-Area ¹	Total Area (sq mi)	General ² Soil Unit	EXISTING						FUTURE			
			Land ³ Use	% Total Area	Curve ⁴ Number	Composite Curve Number Cond. II	Composite Curve Number Cond. III	Average ⁵ Curve Number	Curve ⁶ Number	Composite Curve Number Cond. II	Composite Curve Number Cond. III	Average ⁵ Curve Number
SB-1B	2.13	BCK	SFR	8	79.6	72.1	86.1	74.9	83.1	83.1	93.0	85.1
			UNDEV	92	71.4	---	---	---				
SB-1C	0.85	BCK	SFR	20	79.6	73.0	87.0	75.8	83.1	83.1	93.0	85.1
			UNDEV	80	71.4	---	---	---				
SB-1D	1.64	BCK	SFR	22	79.6	73.2	87.2	76.0	83.1	83.1	93.0	85.1
			C, PU	0	93.2	---	---	---				
			UNDEV	78	71.4	---	---	---				
SB-1E	1.55	BCK	SFR	8	79.6	73.2	87.2	76.0	83.1	83.2	93.0	85.2
			C, PU	1	93.2	---	---	---				
			UNDEV	87	71.4	---	---	---				
			P	4	74.8	---	---	---				
DR-3A	1.58	BCK	MF, MH	1	87.9	78.1	87.1	75.9	87.9	83.8	93.0	85.6
			C, PU	7	93.2	---	---	---				
			UNDEV	92	71.4	---	---	---				
DR-3B	2.20	BCK	SFR	30	79.6	75.6	88.4	78.0	83.1	83.8	93.0	85.6
			C, PU	7	93.2	---	---	---				
			UNDEV	63	71.4	---	---	---				
DR-3C	2.27	BCK	SFR	30	79.6	73.9	87.9	76.7	83.1	83.1	93.0	85.1
			UNDEV	70	71.4	---	---	---				
DR-3D	2.09	BCK	SFR	64	79.6	76.6	89.0	79.1	83.1	83.1	93.0	85.1
			UNDEV	36	71.4	---	---	---				
SB-2A	2.72	MI	P	12	79.0	72.9	86.9	75.7	86.0	83.6	93.0	85.5
		BCK	P	15	74.8	---	---	---				
		MI	UNDEV	6	76.0	---	---	---				
		BCK	UNDEV	52	71.4	---	---	---				
		BCK	SFR	15	79.6	---	---	---				
SB-2B	1.28	MI	UNDEV	11	76.0	78.6	90.6	81.0	86.0	85.1	94.0	86.9
		BCK	UNDEV	26	71.4	---	---	---				
		MI	C, PU	7	94.0	---	---	---				
		BCK	C, PU	5	93.2	---	---	---				
		BCK	SFR	43	79.6	---	---	---				
		BCK	MF, MH	8	87.9	---	---	---				

A-27

TABLE A-1 (Cont'd)

Sub-Area ¹	EXISTING					FUTURE						
	Total Area (sq mi)	General ² Soil Unit	Land ³ Use	% Total Area	Curve ⁴ Number	Composite Curve Number Cond. II	Composite Curve Number Cond. III	Average ⁵ Curve Number	Curve ⁶ Number	Composite Curve Number Cond. II	Composite Curve Number Cond. III	Average ⁵ Curve Number
GR-3A	1.93	BCK	SFR	12	79.6	85.3	94.0	87.0	83.1	88.2	95.2	89.6
			MF, MH	32	87.9	---	---	---	87.9			
			C, PU	35	93.2	---	---	---	93.2			
			UNDEV	21	71.4	---	---	---	83.1			
GR-3B	1.57	MI BCK MI BCK BCK	C, PU	1	94.0	74.6	88.0	77.3	94.0	84.9	93.9	86.7
			C, PU	12	93.9	---	---	---	94.0			
			UNDEV	14	76.0	---	---	---	86.0			
			UNDEV	68	71.4	---	---	---	83.1			
			SFR	5	79.6	---	---	---	83.1			
GR-3C	2.84	MI BCK MI BCK BCK BCK	C, PU	1	94.0	75.6	88.6	78.2	94.0	84.6	93.6	86.4
			C, PU	2	93.9	---	---	---	94.0			
			UNDEV	34	76.0	---	---	---	86.0			
			UNDEV	34	71.4	---	---	---	83.1			
			SFR	25	79.6	---	---	---	83.1			
			MF, MH	4	87.9	---	---	---	87.9			
GR-3D	1.11	BCK	SFR	65	79.6	78.9	90.9	81.3	83.1	84.1	93.4	85.9
			C, PU	10	93.2	---	---	---	93.2			
			UNDEV	25	71.4	---	---	---	83.1			
GR-3E	1.65	MI BCK MI BCK	SFR	1	83.0	75.3	88.3	77.9	86.0	84.8	93.8	86.6
			SFR	15	79.6	---	---	---	83.1			
			UNDEV	56	76.0	---	---	---	86.0			
			UNDEV	28	71.4	---	---	---	83.1			
GR-3F	2.00	MI BCK BCK	UNDEV	23	76.0	73.8	87.8	76.6	86.0	83.8	93.0	85.6
			UNDEV	51	71.4	---	---	---	83.1			
			SFR	25	79.6	---	---	---	83.1			
GR-3G	1.48	MI BCK MI BCK MI	SFR	6	83.0	76.5	89.0	79.0	86.0	85.3	94.0	87.0
			SFR	23	79.6	---	---	---	83.1			
			UNDEV	69	76.0	---	---	---	86.0			
			UNDEV	0	71.4	---	---	---	83.1			
			P	1	79.0	---	---	---	86.0			
GR-3H	1.57	MI BCK BCK BCK	UNDEV	7	76.0	77.2	89.2	79.6	86.0	83.5	93.0	85.4
			UNDEV	29	71.4	---	---	---	83.1			
			SFR	62	79.6	---	---	---	83.1			
			C, PU	2	93.2	---	---	---	93.2			

A-28

TABLE A-1 (Cont'd)

Sub-Area ¹	Total Area (sq mi)	EXISTING							FUTURE			
		General ² Soil Unit	Land ³ Use	% Total Area	Curve ⁴ Number	Composite Curve Number Cond. II	Composite Curve Number Cond. III	Average ⁵ Curve Number	Curve ⁶ Number	Composite Curve Number Cond. II	Composite Curve Number Cond. III	Average ⁵ Curve Number
GIL-A	2.29	BCK	SFR	47	79.6	77.7	89.7	80.1	83.1	84.2	93.2	86.0
			C, PU	11	93.2	---	---	---	93.2			
			UNDEV	42	71.4	---	---	---	83.1			
GIL-B	1.69	BCK	SFR	40	79.6	77.5	89.5	79.9	83.1	84.4	93.4	86.2
			C, PU	13	93.2	---	---	---	93.2			
			UNDEV	47	71.4	---	---	---	83.1			
GIL-C	2.24	BCK	SFR	43	79.6	75.8	88.8	78.4	83.1	83.5	93.0	85.4
			C, PU	4	93.2	---	---	---	93.2			
			UNDEV	53	71.4	---	---	---	83.1			
GIL-D	1.39	MI	SFR	8	83.0	75.1	88.1	77.7	86.0	84.0	93.0	85.8
		BCK	SFR	23	79.6	---	---	---	83.1			
		MI	P	7	79.0	---	---	---	86.0			
		BCK	P	6	74.8	---	---	---	83.1			
		MI	UNDEV	10	76.0	---	---	---	86.0			
		BCK	UNDEV	44	71.4	---	---	---	83.1			
		BCK	C, PU	2	93.2	---	---	---	93.2			
GIL-E	2.34	BCK	SFR	52	79.6	82.8	92.8	84.8	83.1	86.2	94.2	87.8
			C, PU	34	92.3	---	---	---	92.3			
			UNDEV	14	71.4	---	---	---	83.1			
GIL-F	1.14	BCK	SFR	38	79.6	74.6	88.0	77.3	83.1	83.5	93.0	85.4
			C, PU	4	92.3	---	---	---	92.3			
			UNDEV	58	71.4	---	---	---	83.1			
GR-4A	1.96	MI	SFR	5	83.0	78.2	90.2	80.6	86.0	85.0	94.0	86.8
		BCK	SFR	28	79.6	---	---	---	83.1			
		BCK	MF, MH	10	87.9	---	---	---	87.9			
		BCK	C, PU	5	93.2	---	---	---	93.2			
		MI	UNDEV	26	76.0	---	---	---	86.0			
		BCK	UNDEV	26	71.4	---	---	---	83.1			
GR-4B	1.63	MI	SFR	13	83.0	78.3	90.3	80.7	86.0	84.7	93.7	86.5
		BCK	SFR	31	79.6	---	---	---	83.1			
		MI	UNDEV	34	76.0	---	---	---	86.0			
		BCK	UNDEV	15	71.4	---	---	---	83.1			
		MI	P	8	79.0	---	---	---	86.0			

A-29

TABLE A-1 (Cont'd)

Sub-Area ¹	Total Area (sq mi)	EXISTING							FUTURE			
		General ² Soil Unit	Land ³ Use	% Total Area	Curve ⁴ Number	Composite Curve Number Cond. II	Composite Curve Number Cond. III	Average ⁵ Curve Number	Curve ⁶ Number	Composite Curve Number Cond. II	Composite Curve Number Cond. III	Average ⁵ Curve Number
GR-4C	1.63	MI	SFR	4	83.0	79.7	91.0	82.0	86.0	88.8	95.8	90.2
		BCK	SFR	10	79.6	---	---	---	83.1			
		MI	C, PU	7	94.0	---	---	---	94.0			
		BCK	C, PU	4	93.2	---	---	---	93.2			
		MK	UNDEV	35	76.0	---	---	---	86.0			
		BCK	UNDEV	11	71.4	---	---	---	83.1			
		MI	P	32	79.0	---	---	---	86.0			
GV-1A	0.72	BCK	SFR	58	79.6	77.0	89.0	79.4	83.1	84.5	93.5	86.3
			MF, MH	1	87.9	---	---	---	87.9			
			C, PU	13	93.2	---	---	---	93.2			
			UNDEV	28	71.4	---	---	---	83.1			
GV-1B	1.12	BCK	SFR	64	79.6	77.0	89.0	79.4	83.1	83.1	93.0	85.1
			UNDEV	26	71.4	---	---	---	---			
			P	10	74.8	---	---	---	---			
GV-1C	1.21	BCK	SFR	43	79.6	75.5	88.5	78.1	83.1	83.4	93.0	85.3
			MF, MH	6	87.9	---	---	---	87.9			
			UNDEV	41	71.4	---	---	---	83.1			
			P	10	74.8	---	---	---	83.1			
GV-1D	0.66	BCK	SFR	45	79.6	82.1	92.1	84.1	83.1	86.1	94.1	87.7
			C, PU	30	93.2	---	---	---	93.2			
			UNDEV	11	71.4	---	---	---	83.1			
			P	14	74.8	---	---	---	83.1			
GV-1E	0.69	BCK	SFR	100	79.6	79.6	91.0	81.9	83.1	83.1	93.0	85.1
GV-1F	0.85	BCK	SFR	50	79.6	80.1	91.1	82.3	83.1	85.4	94.0	87.1
			MF, MH	3	87.9	---	---	---	87.9			
			C, PU	13	93.2	---	---	---	93.2			
			UNDEV	18	71.4	---	---	---	83.1			
			P	17	74.8	---	---	---	83.1			
GV-1G	0.84	BCK	SFR	91	79.6	78.9	90.9	81.3	83.1	83.1	93.0	85.1
			UNDEV	9	71.4	---	---	---	---			

A-30

TABLE A-1 (Cont'd)

Sub-Area ¹	EXISTING								FUTURE			
	Total Area (sq mi)	General ² Soil Unit	Land ³ Use	% Total Area	Curve ⁴ Number	Composite Curve Number Cond. II	Composite Curve Number Cond. III	Average ⁵ Curve Number	Curve ⁶ Number	Composite Curve Number Cond. II	Composite Curve Number Cond. III	Average ⁵ Curve Number
GV-1H	1.88	BCK	SFR	44	79.6	75.9	88.9	78.5	83.1	83.5	93.0	85.4
			C, PU	4	93.2	---	---	---	93.2			
			UNDEV	51	71.4	---	---	---	83.1			
			P	1	74.8	---	---	---	83.1			
GV-II	1.54	BCK	SFR	45	79.6	78.1	90.1	80.5	83.1	84.5	93.5	86.3
			MF, MH	1	87.9	---	---	---	87.9			
			C, PU	13	93.2	---	---	---	93.2			
			UNDEV	41	71.4	---	---	---	83.1			
OAK-1A	2.90	BCK	UNDEV	100	71.4	76.0	89.09	78.6	83.1	83.1	93.0	85.1
OAK-1B	3.28	BCK	MF, MH	4	87.9	71.6	86.0	74.5	87.9	83.3	93.0	85.2
			UNDEV	84	71.4	---	---	---	83.1			
			P	12	74.8	---	---	---	83.1			
OAK-1C	1.05	BCK	UNDEV	100	71.4	76.0	89.0	78.6	83.1	83.1	93.0	85.1
OAK-1D	1.32	BCK	C, PU	5	93.2	72.5	86.5	75.3	93.2	83.6	93.0	85.5
			UNDEV	95	71.4	---	---	---	83.1			
OAK-1E	2.52	BCK	SFR	12	79.6	75.6	88.6	78.2	83.1	84.1	93.1	85.9
			C, PU	18	93.2	---	---	---	93.2			
			UNDEV	69	71.4	---	---	---	83.1			
OAK-1F	1.23	BCK	SFR	37	79.6	78.4	90.4	80.8	83.1	84.9	93.9	86.7
			C, PU	18	93.2	---	---	---	93.2			
			UNDEV	45	71.4	---	---	---	83.1			
CH-A	0.97	BCK	SFR	2	79.6	72.9	86.9	75.7	83.1	83.7	93.0	85.6
			C, PU	6	93.2	---	---	---	93.2			
			UNDEV	92	71.4	---	---	---	83.1			
CH-B	0.88	BCK	SFR	27	79.6	74.5	88.0	77.2	83.1	83.4	93.0	85.3
			MF, MH	4	87.9	---	---	---	87.9			
			C, PU	1	93.2	---	---	---	93.2			
			UNDEV	68	71.4	---	---	---	83.1			

A-31

TABLE A-1 (Cont'd)

Sub-Area ¹	EXISTING								FUTURE			
	Total Area (sq mi)	General ² Soil Unit	Land ³ Use	% Total Area	Curve ⁴ Number	Composite Curve Number Cond. II	Composite Curve Number Cond. III	Average ⁵ Curve Number	Curve ⁶ Number	Composite Curve Number Cond. II	Composite Curve Number Cond. III	Average ⁵ Curve Number
CH-C	1.30	BCK	SFR	41	79.6	77.6	89.6	80.0	83.1	84.7	93.7	86.5
			MF, MH	2	87.9	---	---	---				
			C, PU	7	93.2	---	---	---				
			UNDEV	43	71.4	---	---	---				
			P	8	74.8	---	---	---				
CH-D	0.72	BCK	C, PU	13	93.2	74.5	88.0	77.2	93.2	84.4	93.4	86.2
			UNDEV	80	71.4	---	---	---				
			P	7	74.8	---	---	---				
CH-E	0.89	BCK	SFR	86	79.6	79.1	91.0	81.5	83.1	83.4	93.0	85.3
			C, PU	3	93.2	---	---	---				
			UNDEV	10	71.4	---	---	---				
			P	1	74.3	---	---	---				
OAK 2A	0.98	BCK	SFR	70	79.6	77.4	89.4	79.8	83.1	83.1	93.0	85.1
			UNDEV	22	71.4	---	---	---				
			P	8	74.8	---	---	---				
OAK 2B	1.52	BCK	SFR	72	79.6	78.3	90.3	80.7	83.1	83.6	93.0	85.5
			MF, MH	1	87.9	---	---	---				
			C, PU	5	93.2	---	---	---				
			UNDEV	22	71.4	---	---	---				
JON A	1.02	BCK	SFR	36	79.6	75.4	88.4	78.0	83.1	83.6	93.0	85.5
			C, PU	5	93.2	---	---	---				
			UNDEV	59	71.4	---	---	---				
JON B	2.10	BCK	SFR	31	79.6	76.0	89	78.6	83.4	83.4	93	85.3
			MF, MH	5	87.9	---	---	---				
			C, PU	9	93.2	---	---	---				
			UNDEV	54	71.4	---	---	---				
JON C	1.83	BCK	SFR	51	79.6	79.8	91.0	82.0	83.1	85.0	94.0	86.8
			MF, MH	3	87.9	---	---	---				
			C, PU	17	93.2	---	---	---				
			UNDEV	29	71.4	---	---	---				

A-32

TABLE A-1 (Cont'd)

Sub-Area ¹	EXISTING								FUTURE			
	Total Area (sq mi)	General ² Soil Unit	Land ³ Use	% Total Area	Curve ⁴ Number	Composite Curve Number Cond. II	Composite Curve Number Cond. III	Average ⁵ Curve Number	Curve ⁶ Number	Composite Curve Number Cond. II	Composite Curve Number Cond. III	Average ⁵ Curve Number
JON D	0.87	BCK	SFR	16	79.6	77.6	89.6	80.0	83.1	85.3	94.0	87.0
			MF, MH	3	87.9	---	---	---	87.9	---	---	---
			C, PU	20	93.2	---	---	---	93.2	---	---	---
			UNDEV	61	71.4	---	---	---	83.1	---	---	---
GU2A	1.51	BCK	SFR	71	79.6	78.4	90.4	80.8	83.1	83.6	93.0	85.5
			C, PU	5	93.2	---	---	---	93.2	---	---	---
			UNDEV	22	71.4	---	---	---	83.1	---	---	---
			P	2	74.8	---	---	---	83.1	---	---	---
GU2B	2.49	BCK	SFR	60	79.6	78.1	90.1	80.5	83.1	83.8	93.0	85.6
			C, PU	7	93.2	---	---	---	93.2	---	---	---
			UNDEV	25	71.4	---	---	---	83.1	---	---	---
			P	8	74.8	---	---	---	83.1	---	---	---
GU2C	0.51	BCK	SFR	57	79.6	86.3	92.0	83.4	83.1	85.5	94.0	87.2
			C, PU	24	93.2	---	---	---	93.2	---	---	---
			UNDEV	19	71.4	---	---	---	83.1	---	---	---
GU2D	0.74	BCK	SFR	36	79.7	79.6	91.0	81.9	83.1	85.5	94.0	87.2
			C, PU	24	93.2	---	---	---	93.2	---	---	---
			UNDEV	40	71.4	---	---	---	83.1	---	---	---
GU2E	0.76	BCK	SFR	35	79.7	76.0	89.0	78.6	83.1	83.9	93.0	85.7
			C, PU	8	93.2	---	---	---	93.2	---	---	---
			UNDEV	57	71.4	---	---	---	83.1	---	---	---
GU2F	0.70	BCK	SFR	79	79.7	82.4	92.4	84.4	83.1	85.6	94.0	87.3
			C, PU	17	93.2	---	---	---	93.2	---	---	---
			UNDEV	5	71.4	---	---	---	83.1	---	---	---
GU2G	1.14	BCK	SFR	21	79.6	82.2	92.2	84.2	83.1	86.8	94.8	88.4
			MF, MH	13	87.9	---	---	---	87.9	---	---	---
			C, PU	31	93.2	---	---	---	93.2	---	---	---
			UNDEV	29	71.4	---	---	---	83.1	---	---	---
			P	6	74.8	---	---	---	83.1	---	---	---
GU2H	0.50	BCK	SFR	73	79.7	78.0	90.0	80.4	83.1	83.1	93.0	85.1
			UNDEV	11	71.4	---	---	---	---	---	---	---
			P	16	74.8	---	---	---	---	---	---	---

A-33

TABLE A-1 (Cont'd)

Sub-Area ¹	EXISTING								FUTURE			
	Total Area (sq mi)	General ² Soil Unit	Land ³ Use	% Total Area	Curve ⁴ Number	Composite Curve Number Cond. II	Composite Curve Number Cond. III	Average ⁵ Curve Number	Curve ⁶ Number	Composite Curve Number Cond. II	Composite Curve Number Cond. III	Average ⁵ Curve Number
GU2I	3.35	BCK	SFR	39	79.6	78.8	90.8	81.2	83.1	84.1	93.1	85.9
			C, PU	26	93.2	---	---	---	93.2			
			UNDEV	33	71.4	---	---	---	83.1			
H-1A	2.67	BCK	SFR	74	79.6	77.7	89.7	80.1	83.1	83.2	93.0	85.2
			C, PU	1	93.2	---	---	---	93.2			
			UNDEV	25	71.4	---	---	---	83.1			
H-1B	1.04	BCK	SFR	77	79.6	77.7	89.7	80.1	83.1	83.1	93.0	85.1
			UNDEV	23	71.4	---	---	---				
H-1C	2.06	BCK	SFR	76	79.6	80.2	91.2	82.4	83.1	84.7	93.7	86.5
			MF, MH	2	87.9	---	---	---	87.9			
			C, PU	7	93.2	---	---	---	93.2			
			UNDEV	16	71.4	---	---	---	83.1			
H-1D	2.10	BCK	SFR	36	79.6	75.8	88.8	78.4	83.1	83.4	93.0	85.3
			C, PU	3	93.2	---	---	---	93.2			
			UNDEV	38	71.4	---	---	---	83.1			
			P	23	74.8	---	---	---	83.1			
H-1E	2.72	BCK	SFR	74	79.6	78.9	90.9	81.3	83.1	83.8	93.0	85.6
			MF, MH	1	87.9	---	---	---	87.9			
			C, PU	6	93.2	---	---	---	93.2			
			UNDEV	19	71.4	---	---	---	83.1			
H-1F	2.83	BCK	SFR	37	79.6	75.4	88.4	78.0	83.1	83.8	93.0	85.6
			MF, MH	1	87.9	---	---	---	87.9			
			C, PU	6	93.2	---	---	---	93.2			
			UNDEV	48	71.4	---	---	---	83.1			
			P	8	74.8	---	---	---	83.1			
H-2A	1.44	BCK	SFR	40	79.6	81.9	92.0	83.9	83.1	86.4	94.4	88.0
			C, PU	33	93.2	---	---	---	93.2			
			UNDEV	27	71.4	---	---	---	83.1			
			P	0	74.8	---	---	---	83.1			
DR-4A	1.69	BCK	SFR	42	79.6	75.3	88.3	77.9	83.1	83.3	93.0	85.2
			C, PU	2	93.2	---	---	---	93.2			
			UNDEV	56	71.4	---	---	---	83.1			

A-34

TABLE A-1 (Cont'd)

Sub-Area ¹	Total Area (sq mi)	General ² Soil Unit	Land ³ Use	EXISTING					FUTURE			
				% Total Area	Curve ⁴ Number	Composite Curve Number Cond. II	Composite Curve Number Cond. III	Average ⁵ Curve Number	Curve ⁶ Number	Composite Curve Number Cond. II	Composite Curve Number Cond. III	Average ⁵ Curve Number
DR-4B	2.69	BCK	SFR	29	79.6	78.6	90.6	81.0	83.1	85.8	94.0	87.4
			C, PU	19	93.2	---	---	---	93.2			
			UNDEV	53	71.4	---	---	---	83.1			
DR-4C	0.87	BCK	SFR	26	79.6	79.0	91.0	81.4	83.1	86.2	94.2	87.8
			C, PU	22	93.2	---	---	---	93.2			
			UNDEV	53	71.4	---	---	---	83.1			
H-2B	2.45	BCK	SFR	49	79.6	77.3	89.3	79.7	83.1	84.0	93.0	85.8
			C, PU	9	93.2	---	---	---	93.2			
			UNDEV	42	71.4	---	---	---	83.1			
H-2C	1.35	BCK	SFR	62	79.6	84.2	93.2	84.4	83.1	87.3	95.0	88.8
			C, PU	32	93.2	---	---	---	93.2			
			UNDEV	6	71.4	---	---	---	83.1			
			P	1	74.8	---	---	---	83.1			
H-3A	2.91	BCK	SFR	7	79.6	78.9	90.9	81.3	83.1	86.2	94.2	87.8
			C, PU	25	93.2	---	---	---	93.2			
			UNDEV	60	71.4	---	---	---	83.1			
			I	8	89.7	---	---	---	89.7			
H-3B	6.61	BCK	SFR	12	79.6	74.6	88.0	77.3	83.1	84.1	93.1	85.9
			C, PU	10	93.2	---	---	---	93.2			
			UNDEV	78	71.4	---	---	---	83.1			
H-3C	2.01	BCK	MF, MH	4	87.9	82.4	92.4	84.4	82.9	88.3	95.3	89.7
		MI	C, PU	14	94.0	---	---	---	94.0			
		BCK	C, PU	27	93.2	---	---	---	93.2			
		MI	UNDEV	27	76.0	---	---	---	86.0			
		BCK	UNDEV	28	71.4	---	---	---	83.1			
GR-5	2.22	MI	SFR	2	83.0	78.9	90.9	81.3	86.0	87.2	95.0	88.8
		BCK	SFR	1	79.6	---	---	---	83.1			
		MI	C, PU	23	94.0	---	---	---	94.0			
		BCK	C, PU	2	93.2	---	---	---	93.2			
		MI	UNDEV	18	76.0	---	---	---	86.0			
		BCK	UNDEV	55	71.4	---	---	---	83.1			

A-35

TABLE A-1 (Cont'd)

Sub-Area ¹	Total Area (sq mi)	General ² Soil Unit	Land ³ Use	EXISTING					FUTURE				
				% Total Area	Curve ⁴ Number	Composite Curve Number Cond. II	Composite Curve Number Cond. III	Average ⁵ Curve Number	Curve ⁶ Number	Composite Curve Number Cond. II	Composite Curve Number Cond. III	Average ⁵ Curve Number	
GRU-1A	1.13	BCK	SFR	11	79.7	85.9	94.0	87.5	83.1	89.3	96.0	90.6	
			MF, MH	3	87.9	---	---	---	87.9				
			C, PU	60	93.2	---	---	---	93.2				
			UNDEV	26	71.4	---	---	---	83.1				
GRU-1B	0.50	BCK	C, PU	47	93.2	---	---	---	93.2	87.8	95.0	89.2	
			UNDEV	53	71.4	81.6	92.0	83.7	83.1				
GRU-2	0.80	BCK	C, PU	53	93.2	83.0	93.0	84.4	93.2	88.4	95.4	89.8	
			UNDEV	47	71.4	---	---	---	83.1				
GRU-3	0.73	BCK	SFR	16	79.6	76.5	89.0	79.0	83.1	85.5	94.0	87.2	
			C, PU	9	93.2	---	---	---	93.2				
			MI	23	76.0	---	---	---	86.0				
			UNDEV	53	71.4	---	---	---	83.1				
GRU-4	1.00	BCK	SFR	4	83.0	78.3	90.3	80.7	86.0	84.6	93.6	86.4	
			SFR	36	79.6	---	---	---	83.1				
			C, PU	11	93.2	---	---	---	93.2				
			UNDEV	29	71.4	---	---	---	83.1				
			MI	9	79.0	---	---	---	86.0				
			P	11	74.8	---	---	---	83.1				
WD-1A	0.56	BCK	SFR	38	79.6	82.8	92.0	84.6	83.1	86.8	94.8	88.4	
			C, PU	37	93.2	---	---	---	93.2				
			UNDEV	20	71.4	---	---	---	83.1				
			P	5	---	---	---	---	83.1				
WD-1B	0.69	BCK	SFR	43	79.6	85.8	94.0	87.4	83.1	87.5	95.0	89.0	
			MF, MH	4	87.9	---	---	---	87.9				
			C, PU	50	93.2	---	---	---	93.2				
			UNDEV	2	71.4	---	---	---	83.1				
WD-1C	0.98	BCK	C, PU	23	93.2	77.1	89.1	79.5	93.2	85.4	94.0	87.1	
			UNDEV	55	71.4	---	---	---	83.1				
			P	22	74.8	---	---	---	83.1				
WD-1D	1.01	BCK	SFR	27	79.6	76.1	89.0	78.7	83.1	84.1	93.1	85.9	
			C, PU	3	93.2	---	---	---	93.2				
			UNDEV	60	71.4	---	---	---	83.1				
			I	10	89.7	---	---	---	89.7				

A-36

TABLE A-1 (Cont'd)

Sub-Area ¹	EXISTING						FUTURE					
	Total Area (sq mi)	General ² Soil Unit	Land ³ Use	% Total Area	Curve ⁴ Number	Composite Curve Number Cond. II	Composite Curve Number Cond. III	Average ⁵ Curve Number	Curve ⁶ Number	Composite Curve Number Cond. II	Composite Curve Number Cond. III	Average ⁵ Curve Number
WDT-A	1.76	BCK	SFR	5	79.6	79.2	91.0	81.6	83.1	86.5	94.5	88.1
			C, PU	33	93.2	---	---	---	93.2			
			UNDEV	61	71.4	---	---	---	83.1			
			I	1	89.4	---	---	---	89.7			
WDT-B	1.07	BCK	SFR	4	79.6	92.2	97.2	93.2	83.1	92.6	97.6	93.6
			C, PU	94	93.2	---	---	---	93.2			
			UNDEV	2	71.4	---	---	---	83.1			
WDT-C	1.20	BCK	SFR	21	79.6	77.7	89.7	80.1	83.1	85.2	94.0	87.0
			C, PU	21	93.2	---	---	---	93.2			
			UNDEV	58	71.4	---	---	---	83.1			
WDT-D	0.49	BCK	SFR	56	79.6	80.8	91.8	83.0	83.1	85.3	94.0	87.0
			C, PU	22	93.2	---	---	---	93.2			
			UNDEV	22	71.4	---	---	---	83.1			
WDT-E	0.62	MI BCK BCK MI BCK	SFR	19	83.0	78.2	90.2	80.6	86.0	84.1	93.1	85.9
			SFR	44	79.6	---	---	---	83.1			
			C, PU	3	93.2	---	---	---	93.2			
			UNDEV	7	76.0	---	---	---	86.0			
			UNDEV	27	71.4	---	---	---	83.1			
WD-2A	1.28	BCK	SFR	25	79.6	75.2	88.2	77.8	83.1	83.9	93.0	85.7
			C, PU	8	93.2	---	---	---	93.2			
			UNDEV	67	71.4	---	---	---	83.1			
WD-2B	0.95	BCK	SFR	97	79.6	79.4	91.0	82.7	83.1	83.1	93.0	85.1
			UNDEV	3	71.4	---	---	---	---			
WD-2C	1.21	BCK	SFR	58	79.6	77.7	89.7	80.1	83.1	83.8	93.0	85.6
			C, PU	7	93.2	---	---	---	93.2			
			UNDEV	35	71.4	---	---	---	83.1			
WD-2D	1.76	BCK	SFR	57	79.6	78.5	90.5	80.9	83.1	84.1	93.1	85.9
			MF, MH	1	87.9	---	---	---	87.9			
			C, PU	9	93.2	---	---	---	93.2			
			UNDEV	24	71.4	---	---	---	83.1			
			P	9	74.8	---	---	---	83.1			

A-37

TABLE A-1 (Cont'd)

Sub-Area ¹	Total Area (sq mi)	General ² Soil Unit	Land ³ Use	EXISTING					FUTURE			
				% Total Area	Curve ⁴ Number	Composite Curve Number Cond. II	Composite Curve Number Cond. III	Average ⁵ Curve Number	Curve ⁶ Number	Composite Curve Number Cond. II	Composite Curve Number Cond. III	Average ⁵ Curve Number
WD-2E	1.21	BCK	SFR	51	79.6	78.9	90.9	81.3	83.1	84.3	93.3	86.1
			MF, MH	7	87.9	---	---	---	87.9			
			C, PU	5	93.2	---	---	---	93.2			
			UNDEV	31	71.4	---	---	---	83.1			
			I	6	89.7	---	---	---	89.7			
WD-2F	0.57	MI	UNDEV	64	76.0	74.3	88.0	77.0	86.0	85.0	94.0	86.8
		BCK	UNDEV	36	71.4	---	---	---	83.1			
WD-3A	0.90	BCK	SFR	88	79.6	79.2	91.0	81.6	83.1	83.7	93.0	85.6
			C, PU	6	93.2	---	---	---	93.2			
			UNDEV	6	71.4	---	---	---	83.1			
WD-3B	0.70	BCK	SFR	91	79.6	78.9	90.9	81.3	83.1	83.1	93.0	85.1
			UNDEV	9	71.4	---	---	---	---			
WD-3C	0.75	MI	SFR	8	83.0	82.9	92.0	84.9	86.0	87.9	95.0	89.3
		BCK	SFR	6	79.6	---	---	---	83.1			
		MI	C, PU	3	94.0	---	---	---	94.0			
		BCK	C, PU	33	93.2	---	---	---	93.2			
		MI	UNDEV	15	76.0	---	---	---	86.0			
		BCK	UNDEV	26	71.4	---	---	---	83.1			
		BCK	MF, MH	9	87.9	---	---	---	87.9			
SK-A	2.24	BCK	SFR	10	79.6	72.7	86.7	75.5	83.1	90.5	96.5	91.7
			MF, MH	3	87.9	---	---	---	87.4			
			UNDEV	87	91.4	---	---	---	91.4			
SK-B	2.08	MI	SFR	4	83.0	76.0	89.0	78.6	86.0	84.6	93.6	86.4
		BCK	SFR	5	79.6	---	---	---	83.1			
		MI	C, PU	1	94.0	---	---	---	94.0			
		BCK	C, PU	11	93.2	---	---	---	93.2			
		MI	UNDEV	24	76.0	---	---	---	86.0			
		BCK	UNDEV	50	71.4	---	---	---	83.1			
		BCK	I	4	89.7	---	---	---	89.7			
GRU5A	1.04	BCK	SFR	67	79.6	78.2	90.2	80.6	83.1	83.1	93.0	85.1
			MF, MH	3	87.9	---	---	---	87.9			
			C, PU	7	93.2	---	---	---	93.2			
			UNDEV	22	71.4	---	---	---	83.1			

A-38

TABLE A-1 (Cont'd)

Sub-Area ¹	Total Area (sq mi)	General ² Soil Unit	Land ³ Use	EXISTING					FUTURE			
				% Total Area	Curve ⁴ Number	Composite Curve Number Cond. II	Composite Curve Number Cond. III	Average ⁵ Curve Number	Curve ⁶ Number	Composite Curve Number Cond. II	Composite Curve Number Cond. III	Average ⁵ Curve Number
GRUSB	0.43	BCK	MI, MH	15	87.9	82.4	92.4	84.4	83.1	87.0	95.0	88.6
			C, PU	39	93.2	---	---	---	93.2			
			UNDEV	46	71.4	---	---	---	83.1			
GRUSC	0.61	BCK	SFR	55	79.6	76.5	89.0	79.0	83.1	83.1	93.0	85.1
			P	16	74.8							
			UNDEV	29	71.4							
GR-6	4.73	MI MI BCK MI BCK	SFR	10	83.0	76.2	89.0	78.8	86.0	85.0	94.0	86.8
			C, PU	5	94.0	---	---	---	94.0			
			C, PU	1	93.2	---	---	---	93.2			
			UNDEV	50	76.0	---	---	---	86.0			
			UNDEV	34	71.4	---	---	---	83.1			
GR-7	6.12	MI BCK MI BCK	SFR	10	83.0	76.3	89.0	78.8	86.0	84.8	93.8	86.6
			SFR	9	79.6	---	---	---	83.1			
			UNDEV	49	76.0	---	---	---	86.0			
			UNDEV	33	71.4	---	---	---	83.1			
GRU-6A	1.15	BCK	SFR	81	79.6	82.3	92.4	84.3	83.1	85.5	94.0	87.2
			C, PU	16	93.2	---	---	---	93.2			
			UNDEV	3	71.4	---	---	---	83.1			
			P	1	74.8	---	---	---	83.1			
GRU-6B	1.50	BCK	SFR	50	79.6	81.2	92.0	83.4	83.1	85.2	94.0	87.0
			MF, MH	1	87.9	---	---	---	87.9			
			C, PU	28	93.2	---	---	---	93.2			
			P	3	74.8	---	---	---	83.1			
			UNDEV	17	71.4	---	---	---	83.1			
GRU-6C	0.96	BCK	C, PU	85	93.2	89.9	96.0	91.1	93.2	91.7	97.0	92.8
			UNDEV	15	71.4	---	---	---	83.1			
GRU-6D	0.75	BCK	SFR	69	79.6	80.0	91.0	83.2	83.1	84.4	93.4	86.2
			MF, MH	5	87.9	---	---	---	87.9			
			C, PU	10	93.2	---	---	---	93.2			
			UNDEV	16	71.4	---	---	---	83.1			

A-39

TABLE A-1 (Concluded)

Sub-Area ¹	Total Area (sq mi)	General ² Soil Unit	EXISTING						FUTURE			
			Land ³ Use	% Total Area	Curve ⁴ Number	Composite Curve Number Cond. II	Composite Curve Number Cond. III	Average ⁵ Curve Number	Curve ⁶ Number	Composite Curve Number Cond. II	Composite Curve Number Cond. III	Average ⁵ Curve Number
GRU-6E	1.47	BCK	SFR	45	79.6	84.6	93.6	86.4	83.1	86.6	94.6	88.2
			C, PU	4	93.2	---	---	---	93.2			
			I	47	89.7	---	---	---	89.7			
			UNDEV	4	71.4	---	---	---	83.1			
GRU-6F	0.58	BCK	I	72	89.7	84.8	93.8	86.6	87.7	89.7	95.0	89.2
			P	8	74.8	---	---	---	83.1			
			UNDEV	20	71.4	---	---	---	83.1			

Notes:

- 1) Sub-Area locations shown on report maps
- 2) Soil Units: BCK = Bowie-Cuthbert-Kirvin and MI = Mantachie-Iuka
- 3) Land Use: UNDEV = Undeveloped; SFR = Single Family Residential; C = Commercial; PU = Public Use; MF = Multi-Family; MH = Mobil Home; P = Parks; I = Industrial
- 4) Curve Number = A measure of runoff potential based on soil hydrologic condition and classification and land use (SCS Method).
- 5) Average Curve Number: Weighted by area in respective soil/land use classifications.
- 6) Subareas assumed SFR at 5 units/acre in Future condition unless a more intense land use (and corresponding) curve number presently exists.

TABLE A-2
SUBAREA UNIT HYDROGRAPH LAG TIMES FOR EXISTING CONDITIONS
GRACE CREEK WATERSHED

Sub-Area	Sheet Flow				Shallow Concentrated Flow-Paved				Shallow Concentrated Flow-Unpaved				Channel Flow		Tc (hrs)	SCS Lag Time (0.6 Tc) (hrs)
	"n"	Length (ft)	Slope (ft/ft)	Time (hrs)	Length (ft)	Slope (ft/ft)	Velocity (ft/sec)	Time (hrs)	Length (ft)	Slope (ft/ft)	Velocity (ft/sec)	Time (hrs)	Length (ft)	Time (hrs)		
GR-1A	0.40	300'	0.050	0.504	---	---	---	---	1000'	0.050	3.60	0.077	2350'	0.131	0.712	0.427
GR-1B	0.24	300'	0.0167	0.519	---	---	---	---	1400'	0.018	2015	0.181	1400'	0.078	0.778	0.467
GR-1C	0.24	300'	0.0286	0.419	---	---	---	---	2700'	0.025	2.55	0.294	2500'	0.139	0.852	0.511
GR-1D	0.24	300'	0.050	0.335	---	---	---	---	2200'	0.018	2.15	0.284	2100'	0.117	0.736	0.442
GR-1E	0.24	300'	0.033	0.395	---	---	---	---	4650'	0.013	1.85	0.698	0'	0	1.093	0.656
GR-1F	0.24	300'	0.040	0.366	---	---	---	---	2050'	0.041	3.25	0.175	1050'	0.058	0.599	0.359
GR-1G	0.40	300'	0.020	0.727	---	---	---	---	2300'	0.022	2.40	0.266	750'	0.042	1.035	0.621
GR-1H	0.24	300'	0.083	0.273	---	---	---	---	700'	0.033	2.95	0.066	2750'	0.153	0.492	0.295
GR-1I	0.24	300'	0.100	0.254	---	---	---	---	1300'	0.050	3.60	0.100	2200'	0.122	0.476	0.286
GR-1J	0.24	300'	0.017	0.515	---	---	---	---	2000'	0.031	2.85	0.195	900'	0.050	0.760	0.456
GR-1K	0.24	300'	0.025	0.442	---	---	---	---	1800'	0.025	2.55	0.196	2600'	0.144	0.782	0.469
GR-1L	0.24	300'	0.022	0.465	---	---	---	---	2950'	0.025	2.55	0.321	1800'	0.100	0.886	0.532
GRT-A	0.40	300'	0.050	0.504	---	---	---	---	2100'	0.035	3.00	0.194	3400'	0.189	0.887	0.532
GRT-B	0.24	300'	0.050	0.335	---	---	---	---	3500'	0.016	2.05	0.474	1200'	0.067	0.876	0.526
GRT-C	0.24	300'	0.010	0.637	---	---	---	---	1400'	0.046	3.45	0.113	2000'	0.111	0.861	0.517
GRT-D	0.24	300'	0.017	0.515	---	---	---	---	1200'	0.033	2.95	0.113	4200'	0.233	0.861	0.517
GRT-E	0.24	300'	0.030	0.411	---	---	---	---	1850'	0.034	3.00	0.171	1100'	0.061	0.643	0.386
GRT-F	0.24	300'	0.013	0.574	---	---	---	---	700'	0.013	1.85	0.105	3700'	0.206	0.885	0.531
GRT-G	0.24	300'	0.025	0.442	---	---	---	---	1200'	0.044	3.40	0.098	2200'	0.122	0.662	0.397
GR-2A	0.24	300'	0.050	0.335	---	---	---	---	1600'	0.064	4.10	0.108	2800'	0.156	0.599	0.359
GR-2B	0.24	300'	0.020	0.483	---	---	---	---	1800'	0.033	2.95	0.169	2350'	0.131	0.783	0.470
GR-2C	0.24	300'	0.060	0.311	---	---	---	---	2500'	0.034	3.00	0.231	2600'	0.144	0.686	0.412
GR-2D	0.24	300'	0.067	0.298	---	---	---	---	1800'	0.048	3.55	0.141	1600'	0.089	0.528	0.317
GR-2E	0.24	300'	0.100	0.254	---	---	---	---	2100'	0.042	3.30	0.177	4700'	0.261	0.692	0.415
RAY-1A	0.24	300'	0.020	0.483	---	---	---	---	1600'	0.009	1.55	0.287	3700'	0.206	0.976	0.586
RAY-1B	0.24	300'	0.050	0.335	---	---	---	---	3100'	0.014	1.90	0.453	800'	0.044	0.832	0.499
RAY-1C	0.40	300'	0.020	0.727	---	---	---	---	1000'	0.015	2.00	0.139	3100'	0.172	1.038	0.623
RAY-1D	0.24	300'	0.067	0.298	---	---	---	---	800'	0.038	3.15	0.071	4400'	0.244	0.613	0.368
RAY-1E	0.24	300'	0.029	0.416	---	---	---	---	3300'	0.050	3.60	0.255	2450'	0.136	0.807	0.484
RAY-1F	0.24	300'	0.017	0.515	---	---	---	---	1900'	0.027	2.65	0.199	5000'	0.278	0.992	0.595
RAY-1G	0.24	300'	0.033	0.395	---	---	---	---	1000'	0.017	2.10	0.132	6100'	0.339	0.866	0.520
ELM-1A	0.24	300'	0.017	0.515	---	---	---	---	3300'	0.021	2.35	0.390	2500'	0.139	1.044	0.626

A-41

TABLE A-2 (Cont'd)

Sub-Area	Sheet Flow				Shallow Concentrated Flow-Paved				Shallow Concentrated Flow-Unpaved				Channel Flow		SCS	
	"n"	Length (ft)	Slope (ft/ft)	Time (hrs)	Length (ft)	Slope (ft/ft)	Velocity (ft/sec)	Time (hrs)	Length (ft)	Slope (ft/ft)	Velocity (ft/sec)	Time (hrs)	Length (ft)	Time (hrs)	Tc (hrs)	Lag Time (0.6 Tc) (hrs)
ELM-1B	0.24	300'	0.050	0.335	---	---	---	---	200'	0.050	3.60	0.015	3450'	0.192	0.542	0.325
ELM-1C	0.24	300'	0.029	0.416	---	---	---	---	2850'	0.019	2.20	0.360	5100'	0.283	1.059	0.635
RAY-2A	0.24	300'	0.022	0.465	---	---	---	---	1300'	0.033	2.95	0.122	3400'	0.189	0.776	0.466
RAY-2B	0.24	300'	0.025	0.442	---	---	---	---	1400'	0.055	3.80	0.102	1100'	0.069	0.605	0.363
RAY-2C	0.24	300'	0.025	0.442	---	---	---	---	1400'	0.029	2.75	0.141	4900'	0.272	0.855	0.513
DR-2A	0.24	300'	0.050	0.335	---	---	---	---	600'	0.033	2.95	0.056	2000'	0.111	0.502	0.301
DR-2B	0.24	300'	0.025	0.442	---	---	---	---	1400'	0.019	2.20	0.177	2350'	0.131	0.750	0.450
DR-2C	0.24	300'	0.050	0.335	---	---	---	---	1000'	0.035	3.00	0.093	2150'	0.119	0.547	0.328
DR-2D	0.24	300'	0.017	0.515	---	---	---	---	950'	0.046	3.45	0.076	2600'	0.144	0.735	0.441
DR-2E	0.24	300'	0.100	0.254	---	---	---	---	1300'	0.050	3.60	0.100	2350'	0.131	0.485	0.291
DR-2TA	0.24	300'	0.050	0.335	---	---	---	---	1300'	0.025	2.55	0.142	4100'	0.228	0.705	0.423
DR-2TB	0.24	300'	0.017	0.515	---	---	---	---	1350'	0.017	2.10	0.179	2200'	0.122	0.816	0.490
DR-2TC	0.24	300'	0.029	0.416	---	---	---	---	600'	0.025	2.55	0.065	2800'	0.156	0.637	0.382
DR-2TD	0.24	300'	0.025	0.442	---	---	---	---	750'	0.050	3.60	0.058	3850'	0.214	0.714	0.428
DR-2TE	0.24	300'	0.067	0.298	---	---	---	---	2100'	0.036	3.05	0.191	0'	0	0.489	0.293
DR-2TF	0.40	300'	0.050	0.504	---	---	---	---	900'	0.023	2.45	0.102	2300'	0.128	0.734	0.440
DR-2TG	0.24	300'	0.033	0.395	---	---	---	---	1200'	0.027	2.65	0.126	2650'	0.147	0.668	0.401
DR-2TH	0.40	300'	0.050	0.504	---	---	---	---	600'	0.020	2.30	0.072	3000'	0.167	0.743	0.446
DR-2F	0.24	300'	0.100	0.254	---	---	---	---	3200'	0.023	2.45	3.63	4100'	0.228	0.845	0.507
SB-1A	0.011	300'	0.067	0.025	---	---	---	---	1700'	0.020	2.30	0.205	900'	0.050	0.280	0.168
SB-1B	0.011	300'	0.018	0.043	---	---	---	---	1900'	0.021	2.35	0.225	2600'	0.144	0.412	0.247
SB-1C	0.011	300'	0.025	0.038	---	---	---	---	300'	0.025	2.55	0.033	2700'	0.150	0.221	0.133
SB-1D	0.40	300'	0.017	0.776	---	---	---	---	1200'	0.056	3.80	0.088	1600'	0.089	0.953	0.572
SB-1E	0.24	300'	0.033	0.395	---	---	---	---	1850'	0.044	3.40	0.151	1850'	0.103	0.649	0.302
DR-3A	0.24	300'	0.013	0.574	---	---	---	---	2100'	0.026	2.60	0.224	900'	0.050	0.848	0.509
DR-3B	0.24	300'	0.017	0.515	---	---	---	---	1900'	0.045	3.40	0.155	2400'	0.133	0.803	0.482
DR-3C	0.24	300'	0.007	0.735	---	---	---	---	2300'	0.033	2.95	0.217	2000'	0.111	1.063	0.638
DR-3D	0.24	300'	0.025	0.442	---	---	---	---	800'	0.033	2.95	0.075	5300'	0.295	0.811	0.487
SB-2A	0.24	300'	0.100	0.254	---	---	---	---	2900'	0.033	2.95	0.273	4400'	0.244	0.771	0.463
SB-2B	0.24	300'	0.020	0.483	---	---	---	---	3700'	0.022	2.40	0.428	0'	0	0.911	0.547
GR-3A	0.24	300'	0.025	0.442	---	---	---	---	750'	0.038	3.15	0.066	2200'	0.122	0.630	0.378
GR-3B	0.24	300'	0.029	0.416	---	---	---	---	2100'	0.033	2.95	0.198	2000'	0.111	0.725	0.435
GR-3C	0.40	300'	0.017	0.776	---	---	---	---	650'	0.091	4.85	0.037	4200'	0.233	1.046	0.628

A-42

TABLE A-2 (Cont'd)

Sub-Area	Sheet Flow				Shallow Concentrated Flow-Paved				Shallow Concentrated Flow-Unpaved				Channel Flow		Tc (hrs)	SCS Lag Time (0.6 Tc) (hrs)
	"n"	Length (ft)	Slope (ft/ft)	Time (hrs)	Length (ft)	Slope (ft/ft)	Velocity (ft/sec)	Time (hrs)	Length (ft)	Slope (ft/ft)	Velocity (ft/sec)	Time (hrs)	Length (ft)	Time (hrs)		
GR-3D	0.24	300'	0.020	0.483	---	---	---	---	300'	0.025	2.55	0.033	2400'	0.133	0.649	0.389
GR-3E	0.24	300'	0.050	0.335	---	---	---	---	2000'	0.056	3.80	0.146	2600'	0.144	0.625	0.375
GR-3F	0.24	300'	0.025	0.442	---	---	---	---	1300'	0.045	3.40	0.106	2300'	0.128	0.676	0.406
GR-3G	0.24	300'	0.033	0.395	---	---	---	---	2800'	0.025	2.55	0.305	1400'	0.078	0.778	0.467
GR-3H	0.24	300'	0.020	0.483	---	---	---	---	2400'	0.23	2.45	0.272	700'	0.039	0.794	0.476
GIL-A	0.24	300'	0.018	0.504	---	---	---	---	1100'	0.020	2.30	0.133	3250'	0.181	0.818	0.491
GIL-B	0.24	300'	0.013	0.574	---	---	---	---	2000'	0.029	2.75	0.202	1400'	0.078	0.845	0.512
GIL-C	0.24	300'	0.010	0.637	---	---	---	---	1700'	0.045	3.40	0.139	2700'	0.150	0.926	0.556
GIL-D	0.24	300'	0.033	0.395	---	---	---	---	1700'	0.029	2.75	0.172	3500'	0.194	0.761	0.457
GIL-E	0.011	300'	0.014	0.047	---	---	---	---	5400'	0.015	2.00	0.750	0'	0	0.797	0.478
GIL-F	0.40	300'	0.040	0.551	---	---	---	---	1100'	0.033	2.95	0.104	1700'	0.094	0.749	0.449
GR-4A	0.24	300'	0.017	0.515	---	---	---	---	1800'	0.020	2.30	0.217	2300'	0.128	0.860	0.516
GR-4B	0.24	300'	0.011	0.613	---	---	---	---	2200'	0.039	3.20	0.191	500'	0.028	0.832	0.499
GR-4C	0.24	300'	0.050	0.335	---	---	---	---	1500'	0.050	3.60	0.116	3000'	0.167	0.618	0.371
OAK-1A	0.24	300'	0.017	0.515	---	---	---	---	1300'	0.031	2.85	0.127	2650'	0.147	0.789	0.473
OAK-1B	0.40	300'	0.067	0.298	---	---	---	---	400'	0.050	3.60	0.031	5000'	0.278	0.607	0.364
OAK-1C	0.24	300'	0.100	0.254	---	---	---	---	700'	0.057	3.85	0.051	1500'	0.083	0.388	0.233
OAK-1D	0.24	300'	0.050	0.335	---	---	---	---	600'	0.091	4.85	0.034	2300'	0.128	0.497	0.298
OAK-1E	0.24	300'	0.029	0.416	---	---	---	---	2200'	0.025	2.55	0.240	2900'	0.161	0.817	0.490
OAK-1F	0.24	300'	0.100	0.254	---	---	---	---	1800'	0.041	3.25	0.154	1700'	0.094	0.502	0.301
CH-A	0.24	300'	0.20	0.483	---	---	---	---	500'	0.050	3.60	0.039	1600'	0.089	0.611	0.367
CH-B	0.40	300'	0.100	0.254	---	---	---	---	1200'	0.058	3.90	0.085	900'	0.050	0.389	0.233
CH-C	0.24	300'	0.040	0.366	---	---	---	---	1200'	0.071	4.30	0.078	2250'	0.125	0.569	0.341
CH-D	0.24	300'	0.050	0.335	---	---	---	---	1100'	0.055	3.80	0.080	500'	0.028	0.443	0.266
CH-E	0.24	300'	0.029	0.416	---	---	---	---	600'	0.067	4.20	0.040	2100'	0.117	0.573	0.344
OAK-2A	0.24	300'	0.050	0.355	---	---	---	---	1500'	0.054	3.75	0.111	1100'	0.061	0.507	0.304
OAK-2B	0.24	300'	0.029	0.416	---	---	---	---	4100'	0.019	2.20	0.518	2000'	0.111	1.045	0.627
GU-1A	0.24	150'	0.040	0.21	1600'	0.032	3.60	0.12	1000'	0.033	2.90	0.10	0'	0	0.430	0.260
GU-1B	0.24	150'	0.050	0.19	1700'	0.024	3.10	0.150	3000'	0.017	2.10	0.40	0'	0	0.740	0.440
GU-1C	0.24	300'	0.067	0.298	---	---	---	---	3200'	0.11	1.70	0.523	0'	0	0.821	0.493
GU-1D	0.24	150'	0.067	0.170	---	---	---	---	1900'	0.04	3.20	0.160	0'	0	0.330	0.200
GU-1E	0.24	150'	0.050	0.190	2500'	0.025	3.20	0.220	---	---	---	---	0'	0	0.410	0.250
GU-1F	0.24	150'	0.067	0.170	500'	0.015	2.50	0.060	1300'	0.033	2.90	0.120	1000'	0.060	0.410	0.250

A-43

TABLE A-2 (Cont'd)

Sub-Area	Sheet Flow				Shallow Concentrated Flow-Paved				Shallow Concentrated Flow-Unpaved				Channel Flow		T _c (hrs)	SCS Lag Time (0.6 T _c) (hrs)
	"n"	Length (ft)	Slope (ft/ft)	Time (hrs)	Length (ft)	Slope (ft/ft)	Velocity (ft/sec)	Time (hrs)	Length (ft)	Slope (ft/ft)	Velocity (ft/sec)	Time (hrs)	Length (ft)	Time (hrs)		
GU-1G	0.24	150'	0.100	0.140	2500'	0.240	3.20	0.220	---	---	---	---	400'	0.020	0.380	0.230
GU-1H	0.24	300'	0.080	0.277	---	---	---	---	2700'	0.037	3.10	0.242	1500'	0.083	0.602	0.361
GU-1I	0.24	150'	0.050	0.19	1600'	0.038	4.00	0.11	2800'	0.190	2.20	0.5	300'	0.020	0.670	0.400
JON-A	0.24	300'	0.025	0.442	---	---	---	---	1000'	0.010	1.60	0.174	900'	0.050	0.666	0.400
JON-B	0.24	300'	0.050	0.335	---	---	---	---	650'	0.033	2.95	0.061	4400'	0.244	0.640	0.384
JON-C	0.24	300'	0.014	0.557	---	---	---	---	1200'	0.017	2.10	0.159	2700'	0.150	0.866	0.520
JON-D	0.24	300'	0.025	0.442	---	---	---	---	900'	0.057	3.85	0.065	2200'	0.122	0.629	0.377
GU-2A	0.24	300'	0.010	0.637	---	---	---	---	1300'	0.019	2.20	0.164	3300'	0.183	0.984	0.590
GU-2B	0.24	300'	0.013	0.574	---	---	---	---	1400'	0.031	2.85	0.136	2500'	0.139	0.849	0.509
GU-2C	0.24	150'	0.100	0.14	1600'	0.44	4.30	0.010	500'	0.060	4.00	0.04	0'	0	0.280	0.170
GU-2D	0.24	150'	0.050	0.190	1500'	0.033	3.70	0.11	1800'	0.022	2.40	0.210	500'	0.030	0.540	0.320
GU-2E	0.24	150'	0.50	0.190	1950'	0.041	4.10	0.130	200'	0.067	4.20	0.010	500'	0.030	0.360	0.220
GU-2F	0.24	150'	0.100	0.140	1100'	0.060	5.00	0.060	1750'	0.320	2.90	0.170	0'	0	0.370	0.220
GU-2G	0.011	300'	0.100	0.022	---	---	---	---	2500'	0.057	3.85	0.180	200'	0.011	0.213	0.128
GU-2H	0.24	150'	0.067	0.17	1200'	0.014	2.40	0.140	---	---	---	---	1600'	0.090	0.400	0.240
GU-2I	0.24	300'	0.050	0.335	---	---	---	---	2100	0.041	3.25	0.179	3200'	0.178	0.692	0.415
H-1A	0.24	300'	0.014	0.557	---	---	---	---	2800	0.016	2.05	0.379	2000'	0.111	1.047	0.628
H-1B	0.40	300'	0.017	0.776	---	---	---	---	600	0.050	3.60	0.046	2600'	0.144	0.966	0.580
H-1C	0.24	300'	0.067	0.298	---	---	---	---	2700	0.022	2.40	0.313	2000'	0.111	0.722	0.433
H-1D	0.24	300'	0.067	0.448	---	---	---	---	1850	0.033	2.95	0.174	1400'	0.078	0.700	0.420
H-1E	0.24	300'	0.050	0.335	---	---	---	---	950	0.038	3.15	0.084	4300'	0.239	0.658	0.395
H-1F	0.011	300'	0.004	0.078	---	---	---	---	600	0.033	2.95	0.056	5000'	0.278	0.412	0.247
H-2A	0.24	300'	0.014	0.557	---	---	---	---	2600	0.018	2.15	0.336	2000'	0.111	1.004	0.602
DR-4A	0.011	300'	0.025	0.038	---	---	---	---	800	0.018	2.15	0.103	3000'	0.167	0.309	0.185
DR-4B	0.24	300'	0.050	0.335	---	---	---	---	2000	0.029	2.75	0.202	2100'	0.117	0.654	0.392
DR-4C	0.24	300'	0.025	0.442	---	---	---	---	1300	0.023	2.45	0.147	1900'	0.106	0.695	0.417
H-2B	0.24	300'	0.013	0.574	---	---	---	---	3200	0.017	2.10	0.423	2400'	0.133	1.130	0.678
H-2C	0.011	300'	0.020	0.041	---	---	---	---	1600	0.020	2.30	0.193	2100'	0.117	0.351	0.211
H-3A	0.011	300'	0.010	0.054	---	---	---	---	2900	0.011	1.70	0.474	3000'	0.167	0.695	0.417
H-3B	0.24	300'	0.025	0.442	---	---	---	---	1400	0.019	2.20	0.177	5200'	0.289	0.908	0.545
H-3C	0.011	300'	0.25	0.038	---	---	---	---	1000	0.022	2.40	0.116	3800'	0.211	0.365	0.219
WD-1A	0.24	150'	0.100	0.140	2600'	0.020	2.90	0.250	---	---	---	---	0'	0	0.39	0.230
WD-1B	0.24	150'	0.050	0.190	2200'	0.014	2.20	0.280	---	---	---	---	0'	0	0.470	0.280

A-44

TABLE A-2 (Cont'd)

Sub-Area	Sheet Flow				Shallow Concentrated Flow-Paved				Shallow Concentrated Flow-Unpaved				Channel Flow		T _c (hrs)	SCS Lag Time (0.6 T _c) (hrs)
	"n"	Length (ft)	Slope (ft/ft)	Time (hrs)	Length (ft)	Slope (ft/ft)	Velocity (ft/sec)	Time (hrs)	Length (ft)	Slope (ft/ft)	Velocity (ft/sec)	Time (hrs)	Length (ft)	Time (hrs)		
WD-1C	0.24	300'	0.033	0.400	---	---	---	---	2250	0.277	2.60	0.240	1150'	0.060	0.700	0.420
WD-1D	0.24	150'	0.025	0.230	1500'	0.017	2.70	0.150	1500	0.170	2.100	0.20	650'	0.040	0.620	0.370
WD-2A	0.24	300'	0.050	0.340	---	---	---	---	950	0.24	2.50	0.11	2750'	0.190	0.600	0.360
WD-2B	0.24	150'	0.100	0.140	3800'	0.21	3.00	0.350	---	---	---	---	0'	0	0.490	0.290
WD-2C	0.24	150'	0.067	0.170	2700'	0.160	2.60	0.290	---	---	---	---	250'	0.010	0.470	0.280
WD-2D	0.24	150'	0.02	0.280	3700'	0.033	3.70	0.280	---	---	---	---	1950'	0.110	0.670	0.400
WDTA	0.011	150'	0.067	0.010	3400'	0.027	3.40	0.280	---	---	---	---	0'	0	0.280	0.170
WDTB	0.11	150'	0.100	0.010	3650'	0.027	3.30	0.310	---	---	---	---	0'	0	0.320	0.190
WDTC	0.011	150'	0.020	0.020	1750'	0.018	2.70	0.180	---	---	---	---	1400'	0.080	0.280	0.170
WDTD	0.24	150'	0.011	0.350	1500'	0.280	3.40	0.120	1250	0.010	1.60	0.22	0'	0	0.690	0.410
WDTE	0.24	150'	0.012	0.340	2800'	0.014	2.40	0.320	500	0.028	2.70	0.050	0'	0	0.710	0.430
WD-3A	0.24	150'	0.033	6.230	1500'	0.020	2.90	0.140	---	---	---	---	700'	0.040	0.410	0.250
WD-3B	0.24	150'	0.020	0.280	1300'	0.025	3.10	0.120	---	---	---	---	1750'	0.100	0.500	0.300
WD-3C	0.011	150'	0.033	0.020	1600'	0.033	3.70	0.120	100	0.040	3.2	0.01	1850'	0.100	0.250	0.150
GR-5	0.011	150'	0.250	0.020	---	---	---	---	1250	0.018	2.20	0.160	1600'	0.090	0.270	0.160
GRU-1A	0.011	150'	0.067	0.01	3200'	0.023	3.10	0.28	200	.033	2.90	0.020	0'	0	0.310	0.190
GRU-1B	0.011	150'	0.067	0.01	1550'	0.025	3.20	0.13	1200	0.24	2.50	0.130	0'	0	0.270	0.160
GRU-2	0.011	150'	0.016	0.03	2700'	0.014	2.40	0.310	---	---	---	---	10.50'	0.060	0.400	0.240
GRU-3	0.24	150'	0.015	0.310	2200'	0.016	2.60	0.240	1150	0.012	1.80	0.180	0'	0	0.730	0.440
GRU-4	0.24	150'	0.025	0.250	2000'	0.014	2.20	0.250	---	---	---	---	1550'	0.090	0.590	0.350
GR-6	0.24	300'	0.050	0.330	---	---	---	---	2300	0.067	4.20	0.150	1900'	0.110	0.590	0.350
GRU-5A	0.24	150'	0.040	0.210	3800'	0.011	2.10	0.500	---	---	---	---	0'	0	0.710	0.430
GRU-5B	0.24	150'	0.040	0.210	1200'	0.031	3.60	0.09	1200	0.008	1.40	0.240	0'	0	0.540	0.320
GRU-5C	0.240	150'	0.033	0.230	1550'	0.02	2.90	0.150	---	---	---	---	1400'	0.080	0.460	0.280
SK-A	0.24	300'	0.033	0.395	---	---	---	---	750	0.013	1.85	0.113	5500'	0.366	1.267	0.760
SK-B	0.24	300'	0.050	0.335	---	---	---	---	200	0.050	3.60	0.015	5800'	0.322	0.672	0.403
GR-7	0.24	300'	0.010	0.637	---	---	---	---	2700	0.014	1.90	0.395	4700'	0.261	1.293	0.776
GRU-6A	0.24	150'	0.033	0.23	3200'	0.007	1.70	0.500	350	0.050	3.60	0.030	0'	0	0.550	0.330
GRU-6B	0.24	150'	0.030	0.240	2100'	0.011	2.10	0.280	---	---	---	---	1900'	0.110	0.630	0.380
GRU-6C	0.011	150'	0.028	0.020	2450'	0.017	2.60	0.26	250	0.050	3.60	0.020	600'	0.030	0.330	0.200
GRU-6D	0.24	150'	0.040	0.210	1550'	0.038	4.00	0.110	---	---	---	---	1150'	0.060	0.380	0.220
GRU-6E	0.24	150'	0.028	0.240	1850'	0.014	2.20	0.23	---	---	---	---	1650'	0.090	0.560	0.340

A-45

TABLE A-2 (Concluded)

Sub-Area	Sheet Flow				Shallow Concentrated Flow-Paved				Shallow Concentrated Flow-Unpaved				Channel Flow		SCS Lag Time	
	"n"	Length (ft)	Slope (ft/ft)	Time (hrs)	Length (ft)	Slope (ft/ft)	Velocity (ft/sec)	Time (hrs)	Length (ft)	Slope (ft/ft)	Velocity (ft/sec)	Time (hrs)	Length (ft)	Time (hrs)	Tc (hrs)	(0.6 Tc) (hrs)
WD-2E	0.24	300'	0.100	0.250	---	---	---	---	700	0.042	3.30	0.06	2100'	0.120	0.430	0.260
WD-2I	0.24	150'	0.033	0.230	700'	0.029	3.40	0.060	1300	0.023	2.50	0.140	2000'	0.110	0.540	0.320

- Notes:
- 1) "n" = sheet flow roughness factor (dimensionless)
 - 2) Channel flow calculated at 5 feet per second
 - 3) Tc = Time of Concentration

TABLE A-3
SUBAREA AVERAGE SCS RUNOFF CURVE NUMBERS FOR EXISTING AND PROPOSED CONDITIONS
HAWKINS CREEK WATERSHED

Sub-Area ¹	EXISTING								FUTURE				
	Total Area (sq mi)	General ² Soil Unit	Land ³ Use	% Total Area	Curve ⁴ Number	Composite Curve Number Cond. II	Composite Curve Number Cond. III	Average ⁵ Curve Number	% ⁶ Total Area	Curve Number	Composite Curve Number Cond. II	Composite Curve Number Cond. III	Average ⁵ Curve Number
HK-1A	0.81	BCK	UNDEV.	100	71.4	71.4	86.0	74.3	100	83.1	83.1	93.0	85.1
HK-1B	0.89	BCK	UNDEV.	100	71.4	71.4	86.0	74.3	100	83.1	83.1	93.0	85.1
HK-1C	0.70	BCK	UNDEV.	100	71.4	71.4	86.0	74.3	100	83.1	83.1	93.0	85.1
HK-1D	0.89	BCK	UNDEV.	100	71.4	71.4	86.0	74.3	90	83.1	81.9	92.0	83.9
HK-1E	1.53	BCK	UNDEV.	100	71.4	71.4	86.0	74.3	60	83.1	78.4	90.4	80.8
HKT-1	3.21	BCK	UNDEV.	100	71.4	71.4	86.0	74.3	100	71.4	71.4	86.0	74.3
HKT-2	3.37	BCK	UNDEV.	100	71.4	71.4	86.0	74.3	100	71.4	71.4	86.0	74.3
HKT-3A	0.68	BCK	UNDEV.	100	71.4	71.4	86.0	74.3	100	83.1	83.1	93.0	85.1
HKT-3B	1.00	BCK	UNDEV.	100	71.4	71.4	86.0	74.3	100	83.1	83.1	93.0	85.1
HKT-3C	1.39	BCK	UNDEV.	100	71.4	71.4	86.0	74.3	100	83.1	83.1	93.0	85.1
HKT-3D	0.58	BCK	UNDEV.	100	71.4	71.4	86.0	74.3	100	83.1	83.1	93.0	85.1
HKT-3E	0.49	BCK	UNDEV.	100	71.4	71.4	86.0	74.3	100	83.1	83.1	93.0	85.1
HKT-3F	1.65	BCK	UNDEV.	100	71.4	71.4	86.0	74.3	100	83.1	83.1	93.0	85.1
HKT-3G	0.84	BCK	UNDEV.	100	71.4	71.4	86.0	74.3	100	83.1	83.1	93.0	85.1
HKT-3H	1.04	BCK	UNDEV.	100	71.4	71.4	86.0	74.3	100	83.1	83.1	93.0	85.1
HK-2A	0.88	BCK	UNDEV.	100	71.4	71.4	86.0	74.3	90	83.1	81.9	92.0	83.9
HK-2B	0.64	BCK	UNDEV.	100	71.4	71.4	86.0	74.3	50	83.1	77.2	89.2	79.6
HK-3A	1.28	BCK	UNDEV.	100	71.4	71.4	86.0	74.3	50	83.1	77.2	89.2	79.6
HK-3B	1.36	BCK	UNDEV.	100	71.4	71.4	86.0	74.3	60	83.1	78.4	90.4	80.8
HK-3C	0.82	BCK	UNDEV.	100	71.4	71.4	86.0	74.3	40	83.1	76.1	89.0	78.7
LDB-1	4.39	BCK	UNDEV.	100	71.4	71.4	86.0	74.3	100	71.4	71.4	86.0	74.3
HKT-4	11.94	BCK	UNDEV.	100	71.4	71.4	86.0	74.3	100	71.4	71.4	86.0	74.3
HK-4A	0.80	BCK	SFR	3	79.6	71.6	86.0	74.5	40	83.1	76.1	89.0	78.7
			UNDEV.	97	71.4	---	---	---	60	71.4	---	---	---
HK-4B	1.05	BCK	UNDEV.	100	71.4	71.4	86.0	74.3	20	83.1	73.7	87.7	76.5

A-47

TABLE A-3 (Cont'd)

Sub-Area ¹	EXISTING								FUTURE				
	Total Area (sq mi)	General ² Soil Unit	Land ³ Use	% Total Area	Curve ⁴ Number	Composite Curve Number Cond. II	Composite Curve Number Cond. III	Average ⁵ Curve Number	% ⁶ Total Area	Curve Number	Composite Curve Number Cond. II	Composite Curve Number Cond. III	Average ⁵ Curve Number
HK-4C	1.46	BCK	SFR UNDEV.	2 98	79.6 71.4	71.6 --	86.0 --	74.5 --	90 10	83.1 71.4	81.9 --	92.0 --	83.9 --
HK-4D	2.16	BCK	SFR UNDEV.	3 97	79.6 71.4	71.6 --	86.0 --	74.5 --	70 30	83.1 71.4	79.6 --	91.0 --	81.8 --
HK-4E	1.70	BCK	SFR C, PU UNDEV.	3 2 95	79.6 93.2 71.4	72.1 -- --	86.1 -- --	74.9 -- --	48 2 50	83.1 93.2 71.4	77.4 -- --	89.4 -- --	79.8 -- --
HKT-5A	0.95	BCK	UNDEV.	100	71.4	71.4	86.0	74.3	100	83.1	83.1	93.0	85.1
HKT-5B	1.14	BCK	SFR UNDEV.	3 97	79.6 71.4	71.6 --	86.0 --	74.5 --	100 --	83.1 --	83.1 --	93.0 --	85.1 --
HKT-6A	1.07	BCK	UNDEV.	100	71.4	71.4	86.0	74.3	100	83.1	83.1	93.0	85.1
HKT-6B	0.66	BCK	UNDEV.	100	71.4	71.4	86.0	74.3	100	83.1	83.1	93.0	85.1
HKT-6C	1.50	BCK	UNDEV.	100	71.4	71.4	86.0	74.3	100	83.1	83.1	93.0	85.1
HKT-6D	1.08	BCK	UNDEV.	100	71.4	71.4	86.0	74.3	100	83.1	83.1	93.0	85.1
HKT-6E	1.02	BCK	UNDEV.	100	71.4	71.4	86.0	74.3	100	83.1	83.1	93.0	85.1
HKT-6F	0.72	BCK	SFR UNDEV.	3 97	79.6 71.4	71.6 --	86.0 --	74.5 --	100 100	83.1 83.1	83.1 83.1	93.0 93.0	85.1 85.1
HKT-6G	1.54	BCK	SFR UNDEV.	14 86	79.6 71.4	72.5 --	86.5 --	75.3 --	100 --	83.1 --	83.1 --	93.0 --	85.1 --
HKT-7A	0.81	BCK	SFR UNDEV.	9 91	79.6 71.4	72.1 --	86.1 --	74.9 --	100 --	83.1 71.4	83.1 --	93.0 --	85.1 --
HKT-7B	0.57	BCK	UNDEV.	100	71.4	71.4	86.0	74.3	100	83.1	83.1	93.0	85.1
HKT-7C	1.29	BCK	SFR UNDEV.	5 95	79.6 71.4	71.8 --	86.0 --	74.6 --	100 --	83.1 71.4	83.1 --	93.0 --	85.1 --
HKT-7D	0.70	BCK	UNDEV.	100	71.4	71.4	86.0	74.3	100	83.1	83.1	93.0	85.1

A-48

TABLE A-3 (Cont'd)

Sub-Area ¹	EXISTING								FUTURE				
	Total Area (sq mi)	General ² Soil Unit	Land ³ Use	% Total Area	Curve ⁴ Number	Composite Curve Number Cond. II	Composite Curve Number Cond. III	Average ⁵ Curve Number	% ⁶ Total Area	Curve Number	Composite Curve Number Cond. II	Composite Curve Number Cond. III	Average ⁵ Curve Number
HKT-7E	0.92	BCK	UNDEV.	100	71.4	71.4	86.0	74.3	100	83.1	83.1	93.0	85.1
HKT-8	11.20	BCK	UNDEV.	93	71.4	71.7	86.0	74.6	93	71.4	71.7	86.0	74.6
		MI	UNDEV.	7	76.0	---	---	---	7	76.0	---	---	---
HK-5A	1.72	BCK	SFR	2	79.6	75.9	88.9	78.5	10	83.1	78.2	90.2	80.6
		MI	MF, MH	6	90.0	---	---	---	20	90.0	---	---	---
		BCK	UNDEV.	39	71.4	---	---	---	28	71.4	---	---	---
		MI	UNDEV.	54	76.0	---	---	---	42	76.0	---	---	---
HK-5B	1.45	BCK	SFR	4	79.6	74.6	88.0	77.3	71	83.1	81.9	92.0	83.9
		BCK	MF, MH	6	87.9	---	---	---	6	87.9	---	---	---
		MI	MF, MH	1	90.0	---	---	---	1	90.0	---	---	---
		BCK	UNDEV.	68	71.4	---	---	---	---	---	---	---	---
		MI	UNDEV.	22	76.0	---	---	---	22	76.0	---	---	---
HK-5C	1.52	BCK	SFR	1	79.6	74.3	87.3	76.9	45	83.1	79.4	91.0	81.7
		BCK	MF, MH	2	87.9	---	---	---	2	87.9	---	---	---
		BCK	UNDEV.	44	71.4	---	---	---	---	---	---	---	---
		MI	UNDEV.	53	76.0	---	---	---	53	76.0	---	---	---
HKT-9	3.85	BCK	UNDEV.	94	71.4	71.7	86.0	74.6	94	71.4	71.7	86.0	74.0
		MI	UNDEV.	6	76	---	---	---	6	76.0	---	---	---
HKT-10	5.71	BCK	SFR	23	79.6	73.4	87.4	76.2	23	79.6	73.4	87.4	76.2
		BCK	UNDEV.	75	71.4	---	---	---	75	71.4	---	---	---
		MI	UNDEV.	2	76.0	---	---	---	2	76.0	---	---	---
HKT-11A	1.08	BCK	SFR	9	79.6	72.1	86.1	74.9	100	83.1	83.1	93.0	85.1
			UNDEV.	91	71.4	---	---	---	---	---	---	---	---
HKT-11B	1.32	BCK	SFR	20	79.6	73.0	87.0	75.8	100	83.1	83.1	93.0	85.1
			UNDEV.	80	71.4	---	---	---	---	---	---	---	---

A-49

TABLE A-3 (Cont'd)

Sub-Area ¹	EXISTING						FUTURE						
	Total Area (sq mi)	General ² Soil Unit	Land ³ Use	% Total Area	Curve ⁴ Number	Composite Curve Number Cond. II	Composite Curve Number Cond. III	Average ⁵ Curve Number	% ⁶ Total Area	Curve Number	Composite Curve Number Cond. II	Composite Curve Number Cond. III	Average ⁵ Curve Number
HKT-11C	1.31	BCK	SFR	39	79.6	76.1	89.0	78.7	95	83.1	83.1	93.0	85.1
			MF, MH	5	87.9	---	---	---	5	87.9	---	---	---
			UNDEV.	57	71.4	---	---	---	---	---	---	---	---
HKT-11D	0.85	BCK	SFR	11	79.6	72.3	86.3	75.1	100	83.1	83.1	93.0	85.1
			UNDEV.	89	71.4	---	---	---	---	---	---	---	---
HKT-11E	1.60	BCK	SFR	48	79.6	76.3	89.0	78.8	99	83.1	83.2	93.0	85.1
			C, PU	1	93.2	---	---	---	1	93.2	---	---	---
			UNDEV.	52	71.4	---	---	---	---	---	---	---	---
HKT-11F	1.86	BCK	SFR	22	79.6	73.4	87.4	76.2	99	83.1	83.2	93.0	85.1
			MF, MH	1	87.9	---	---	---	1	87.0	---	---	---
			UNDEV.	77	71.4	---	---	---	---	---	---	---	---
HKT-11G	1.40	BCK	SFR	3	79.6	71.8	86.0	74.6	99	83.1	83.2	93.0	85.1
			MF, MH	1	87.9	---	---	---	1	87.9	---	---	---
			UNDEV.	96	71.4	---	---	---	---	---	---	---	---
HKT-11H	1.05	BCK	SFR	8	79.6	72.8	86.8	75.6	96	83.1	83.3	93.0	85.1
			MF, MH	3	87.9	---	---	---	3	87.9	---	---	---
			C, PU	1	93.2	---	---	---	1	93.2	---	---	---
			UNDEV.	88	71.4	---	---	---	---	---	---	---	---
HKT-11I	1.09	BCK	SFR	4	79.6	71.7	86.0	74.6	100	83.1	83.1	93.0	85.1
			UNDEV.	96	71.4	---	---	---	---	---	---	---	---
HKT-11J	0.88	BCK	SFR	27	79.6	74.5	88.0	77.2	96	83.1	83.5	93.0	85.4
			C, PU	4	93.2	---	---	---	4	93.2	---	---	---
			UNDEV.	69	71.4	---	---	---	---	---	---	---	---
HKT-11K	0.95	BCK	SFR	12	79.6	73.5	87.5	76.3	93	83.1	83.3	93.0	85.2
			MF, MH	7	87.9	---	---	---	7	87.8	---	---	---
			UNDEV.	81	71.4	---	---	---	---	---	---	---	---

A-50

TABLE A-3 (Cont'd)

Sub-Area ¹	EXISTING						FUTURE						
	Total Area (sq mi)	General ² Soil Unit	Land ³ Use	% Total Area	Curve ⁴ Number	Composite Curve Number Cond. II	Composite Curve Number Cond. III	Average ⁵ Curve Number	% ⁶ Total Area	Curve Number	Composite Curve Number Cond. II	Composite Curve Number Cond. III	Average ⁵ Curve Number
HKT-11L	1.08	BCK	SFR	8	79.6	72.1	86.1	74.9	100	83.1	83.1	93.0	85.1
			UNDEV.	92	71.4	--	--	--	--	--	--	--	--
HKT-11M	1.64	BCK	SFR	3	79.6	72.1	86.1	74.9	97	83.1	83.2	93.0	85.1
			MF, MH	3	87.9	--	--	--	3	87.9	--	--	--
			UNDEV.	94	71.4	--	--	--	--	--	--	--	--
HKT-11N	1.75	BCK	SFR	18	79.6	73.3	87.3	76.1	98	83.1	83.3	93.0	85.2
			C, PU	2	93.2	--	--	--	2	93.2	--	--	--
			UNDEV.	80	71.4	--	--	--	--	--	--	--	--
HKT-11O	1.72	BCK	SFR	5	79.6	72.9	86.9	75.7	98	83.1	83.2	93.0	85.1
			MF, MH	2	87.9	--	--	--	2	87.9	--	--	--
			UNDEV.	94	71.4	--	--	--	--	--	--	--	--
HKT-11P	2.32	BCK	SFR	9	79.6	73.1	87.1	75.9	97	83.1	83.2	93.0	85.1
		BCK	MF, MH	1	87.9	--	--	--	1	87.9	--	--	--
		BCK	UNDEV.	89	71.4	--	--	--	--	--	--	--	--
		MI	UNDEV.	2	76.0	--	--	--	2	86.0	--	--	--
HKT-12	2.01	BCK	SFR	9	79.6	72.3	86.3	75.1	9	79.6	72.3	86.3	75.1
		BCK	UNDEV.	88	71.4	--	--	--	88	71.4	--	--	--
		MI	UNDEV.	3	76.0	--	--	--	3	76.0	--	--	--
HK-6A	1.01	BCK	UNDEV.	27	71.4	74.8	88.0	77.4	27	83.1	77.9	89.9	80.3
		MI	UNDEV.	73	76.0	--	--	--	73	76.0	--	--	--
HK-6B	2.19	BCK	UNDEV.	58	71.4	73.3	87.3	76.1	58	83.1	80.1	91.1	82.3
		MI	UNDEV.	42	76.0	--	--	--	42	76.0	--	--	--
HKT-13	3.86	BCK	SFR	15	79.6	74.0	88.0	76.8	15	79.6	74.0	88.0	76.8
		BCK	C, PU	5	93.2	--	--	--	5	93.2	--	--	--
		BCK	UNDEV.	75	71.4	--	--	--	75	71.4	--	--	--
		MI	UNDEV.	5	76.0	--	--	--	5	76.0	--	--	--

A-51

TABLE A-3 (Cont'd)

Sub-Area ¹	Total Area (sq mi)	General ² Soil Unit	Land ³ Use	EXISTING					FUTURE				
				% Total Area	Curve ⁴ Number	Composite Curve Number Cond. II	Composite Curve Number Cond. III	Average ⁵ Curve Number	% ⁶ Total Area	Curve Number	Composite Curve Number Cond. II	Composite Curve Number Cond. III	Average ⁵ Curve Number
A-52	HKT-14A	BCK	SFR	35	79.6	76.0	89.0	78.6	96	83.1	83.5	93.0	85.1
			C, PU	4	93.2	---	---	---	4	93.2	---	---	---
			UNDEV.	35	71.4	---	---	---	---	---	---	---	---
			P	26	74.8	---	---	---	---	---	---	---	---
	HKT-14B	BCK	SFR	63	79.6	77.8	89.8	80.2	100	83.1	83.1	93.0	85.1
			UNDEV.	2	71.4	---	---	---	---	---	---	---	---
			P	35	74.8	---	---	---	---	---	---	---	---
	HKT-14C	BCK	SFR	5	79.6	74.9	88.0	77.5	89	83.1	84.2	93.2	86.0
			C, PU	11	93.2	---	---	---	11	93.2	---	---	---
			UNDEV.	65	71.4	---	---	---	---	---	---	---	---
			P	19	74.8	---	---	---	---	---	---	---	---
	HKT-14D	BCK	C, PU	5	93.2	73.1	87.3	75.9	5	93.2	83.6	93.0	85.5
UNDEV			78	71.4	---	---	---	95	83.1	---	---	---	
P			17	74.8	---	---	---	---	---	---	---	---	
HKT-14E	BCK	SFR	21	79.6	73.2	87.2	76.0	96	83.1	83.4	93.0	85.3	
		MF, MH	2	87.9	---	---	---	2	87.9	---	---	---	
		C, PU	2	93.2	---	---	---	2	93.2	---	---	---	
		UNDEV.	74	71.4	---	---	---	---	---	---	---	---	
HKT-14F	BCK	SFR	2	79.6	72.1	86.1	74.9	97	83.1	83.2	93.0	85.2	
		MF, MH	3	87.9	---	---	---	3	87.9	---	---	---	
		UNDEV.	95	71.4	---	---	---	---	---	---	---	---	
HKT-14G	BCK	SFR	24	79.6	79.3	91	81.6	73	83.1	85.8	94.0	87.4	
		C, PU	27	93.2	---	---	---	27	93.2	---	---	---	
		UNDEV.	49	71.4	---	---	---	---	---	---	---	---	
HKT-14H	BCK	SFR	26	79.6	78.5	90.5	80.9	77	83.1	85.4	94.0	87.1	
		C, PU	23	93.2	---	---	---	23	93.2	---	---	---	
		UNDEV.	51	71.4	---	---	---	---	---	---	---	---	

TABLE A-3 (Cont'd)

Sub-Area ¹	EXISTING								FUTURE					
	Total Area (sq mi)	General ² Soil Unit	Land ³ Use	% Total Area	Curve ⁴ Number	Composite Curve Number Cond. II	Composite Curve Number Cond. III	Average ⁵ Curve Number	% ⁶ Total Area	Curve Number	Composite Curve Number Cond. II	Composite Curve Number Cond. III	Average ⁵ Curve Number	
HKT-14I	0.72	BCK	SFR	21	79.6	74.2	88.0	77.0	97	83.1	83.4	93.0	85.3	
			C, PU	3	93.2	---	---	---	3	93.2	---	---	---	
			UNDEV.	65	71.4	---	---	---	---	---	---	---	---	---
			P	11	74.8	---	---	---	---	---	---	---	---	---
HKT-14J	0.77	BCK	SFR	68	79.6	77.0	89.0	79.4	100	83.1	83.1	93.0	85.1	
			UNDEV.	30	71.4	---	---	---	---	---	---	---	---	
			P	2	74.8	---	---	---	---	---	---	---	---	
HKT-14K	1.25	BCK	SFR	24	79.6	74.2	88.0	77	98	83.1	83.3	93.0	85.2	
			C, PU	2	93.2	---	---	---	2	93.2	---	---	---	
			UNDEV.	61	71.4	---	---	---	---	---	---	---	---	
			P	13	74.8	---	---	---	---	---	---	---	---	
HTK-14L	1.50	BCK	SFR	35	79.6	74.7	88.0	77.4	98	83.1	83.3	93.0	85.2	
			C, PU	2	93.2	---	---	---	2	93.2	---	---	---	
			UNDEV.	62	71.4	---	---	---	---	---	---	---	---	
			P	1	74.8	---	---	---	---	---	---	---	---	
HKT-14M	1.43	BCK	SFR	9	79.6	74.4	88.0	77.1	90	83.1	84.1	93.1	85.9	
			C, PU	10	93.2	---	---	---	10	93.2	---	---	---	
			UNDEV.	80	71.4	---	---	---	---	---	---	---	---	
			P	1	74.8	---	---	---	---	---	---	---	---	
HKT-14N	2.03	BCK	SFR	2	79.6	72.2	86.2	75.0	97	83.1	83.4	93.0	85.3	
			C, PU	3	93.2	---	---	---	3	93.2	---	---	---	
			UNDEV.	95	71.4	---	---	---	---	---	---	---	---	
HKT-14O	1.07	BCK MI	UNDEV.	92	71.4	71.8	86.0	74.6	92	83.1	83.3	93.0	85.2	
			UNDEV.	8	76.0	---	---	---	8	86.0	---	---	---	
HK-7A	1.39	BCK	UNDEV.	100	71.4	71.4	86.0	74.3	100	83.1	83.1	93.0	85.1	
HK-7B	0.96	BCK MI	UNDEV.	49	71.4	73.7	87.7	76.5	83.1	81.5	92.0	83.6		
			UNDEV.	51	76.0	---	---	---	76.0	---	---	---		

A-53

TABLE A-3 (Cont'd)

Sub-Area ¹	EXISTING								FUTURE				
	Total Area (sq mi)	General ² Soil Unit	Land ³ Use	% Total Area	Curve ⁴ Number	Composite Curve Number Cond. II	Composite Curve Number Cond. III	Average ⁵ Curve Number	% ⁶ Total Area	Curve Number	Composite Curve Number Cond. II	Composite Curve Number Cond. III	Average ⁵ Curve Number
HK-7C	1.18	BCK MI	UNDEV. UNDEV.	32	71.4	74.5	88.0	77.2	83.1	77.2	89.2	79.6	
				68	76.0	---	---	---					
HK-7D	1.50	BCK MI	UNDEV. UNDEV.	52	71.4	73.6	87.6	76.4	52	83.1	79.7	91.0	82.0
				48	76.0	---	---	---					
HKT-15	2.37	BCK BCK MI	SFR	38	79.6	76.2	89.0	78.8	38	79.6	76.2	89.0	78.8
			UNDEV.	41	71.4	---	---	---					
			UNDEV.	22	76.0	---	---	---					
HKT-16	3.50	BCK BCK MI	SFR	8	79.6	72.6	86.6	75.5	8	79.6	72.6	86.6	75.3
			UNDEV.	81	71.4	---	---	---					
			UNDEV.	11	76.0	---	---	---					
HKT-17A	0.70	BCK	SFR	18	79.6	72.9	86.9	75.7	100	83.1	83.1	93.0	85.1
			UNDEV.	82	71.4	---	---	---					
HKT-17B	0.72	BCK	SFR	18	79.6	75.1	88.1	77.7	90	83.1	84.1	93.1	85.9
			C, PU	10	93.2	---	---	---					
			UNDEV.	72	71.4	---	---	---					
HKT-17C	0.74	BCK	SFR	25	79.6	74.5	88.0	77.2	95	83.1	83.6	93.0	85.5
			C, PU	5	93.2	---	---	---					
			UNDEV.	70	71.4	---	---	---					
HKT-17D	1.80	BCK	C, PU	10	93.2	82.9	92.9	84.9	10	93.2	87.5	95.0	89.0
			UNDEV.	39	71.4	---	---	---					
			I	51	89.7	---	---	---					
HKT-17E	1.36	BCK	SFR	14	79.6	74.0	88.0	76.8	92	83.1	83.6	93.0	85.5
			MF, MH	5	87.9	---	---	---					
			C, PU	3	93.2	---	---	---					
			UNDEV.	78	71.4	---	---	---					

A-54

TABLE A-3 (Cont'd)

Sub-Area ¹	EXISTING								FUTURE				
	Total Area (sq mi)	General ² Soil Unit	Land ³ Use	% Total Area	Curve ⁴ Number	Composite Curve Number Cond. II	Composite Curve Number Cond. III	Average ⁵ Curve Number	% ⁶ Total Area	Curve Number	Composite Curve Number Cond. II	Composite Curve Number Cond. III	Average ⁵ Curve Number
HKT-17F	2.06	BCK	UNDEV. I	75	71.4	75.3	88.3	77.9	75	93.2	84.8	93.8	86.6
				25	89.7	---	---	---	25	89.7	---	---	---
HKT-17G	1.82	BCK MI	UNDEV. UNDEV.	74	71.4	72.6	86.6	75.5	74	83.1	83.8	93.0	85.6
				26	76.0	---	---	---	26	86.0	---	---	---
HK-8	6.09	BCK MI BCK MI	UNDEV. UNDEV.	60	71.4	73.2	87.2	76.0	18	71.4	79.6	91.0	81.9
				40	76.0	---	---	---	27	76.0	---	---	---
									37	83.1	---	---	---
									18	86.0	---	---	---
HKT-19	1.59	BCK	SFR C, PU UNDEV. I	3	79.6	79.0	91.0	81.4	53	83.1	86.4	94.4	88.0
				5	93.2	---	---	---	5	93.2	---	---	---
				50	71.4	---	---	---	---	---	---	---	---
				42	89.7	---	---	---	42	89.7	---	---	---
HKT-18	1.34	BCK	C, PU UNDEV. I	2	93.2	74.6	88.0	77.3	2	93.2	84.8	93.8	86.6
				88	71.4	---	---	---	88	83.1	---	---	---
				11	89.7	---	---	---	11	89.7	---	---	---
HKT-10	8.41	BCK BCK	UNDEV. UNDEV.		83.1				30	83.1	76.7	89.0	79.2
				61	71.4	73.2	87.2	76.0	31	71.4	---	---	---
				39	76.0	---	---	---	39	76.0	---	---	---

A-55

TABLE A-3 (Concluded)

Sub-Area ¹	EXISTING								FUTURE				
	Total Area (sq mi)	General ² Soil Unit	Land ³ Use	% Total Area	Curve ⁴ Number	Composite Curve Number Cond. II	Composite Curve Number Cond. III	Average ⁵ Curve Number	% ⁶ Total Area	Curve Number	Composite Curve Number Cond. II	Composite Curve Number Cond. III	Average ⁵ Curve Number
HK-9	6.16	BCK	UNDEV.	67	71.4	72.9	86.9	75.7	67	71.4	74.9	88.0	77.5
		MI	UNDEV.	33	76.0	---	---	---	13	76.0	---	---	---
										20	86.0	---	---

- Notes:
- 1) Sub-Area locations shown on report maps
 - 2) Soil Units: BCK = Bowie-Cuthbert-Kirvin and MI = Mantachie-Iuka
 - 3) Land Use: UNDEV. = Undeveloped; SFR = Single Family Residential; C = Commercial; PU = Public Use; MF = Multi-Family; MH = Mobil Home; P = Parks; I = Industrial
 - 4) Curve Number = A measure of runoff potential based on soil hydrologic condition and classification and land use (SCS Method).
 - 5) Average Curve Number: Weighted by area in respective soil/land use classifications
 - 6) % Total Area (Future): % area in soil/land use classification for SFR (5 units/acre) unless higher use indicated (e.g., C or I). If % indicated is less than 100%, assume remainder is Undeveloped.

TABLE A-4

SUBAREA UNIT HYDROGRAPH LAG TIMES FOR EXISTING CONDITIONS
HAWKINS CREEK WATERSHED

Sub-Area	Sheet Flow				Shallow Concentrated Flow				Channel Flow		Tc (hrs)	SCS Lag Time (0.6 Tc) (hrs)
	"n"	Length (ft)	Slope (ft/ft)	Time (hrs)	Length (ft)	Slope (ft/ft)	Velocity (ft/sec)	Time (hrs)	Length (ft)	Time (hrs)		
HK-1A	0.24	300'	0.050	0.335	800'	0.031	2.85	0.078	2400'	0.133	0.546	0.328
HK-1B	0.24	300'	0.033	0.395	1900'	0.035	3.00	0.176	1900'	0.106	0.677	0.406
HK-1C	0.24	300'	0.033	0.395	2500'	0.027	2.65	0.262	0'	0	0.657	0.394
HK-1D	0.40	300'	0.050	0.504	2700'	0.031	2.85	0.263	0'	0	0.767	0.460
HK-1E	0.40	300'	0.033	0.595	2450'	0.028	2.70	0.252	1200'	0.067	0.914	0.548
HKT-1	0.40	300'	0.100	0.382	1650'	0.092	4.90	0.094	6300'	0.350	0.826	0.496
HK-2A	0.24	300'	0.050	0.335	2300'	0.038	3.15	0.203	600'	0.033	0.571	0.343
HKT-2	0.24	300'	0.100	0.254	1100'	0.077	4.50	0.068	5400'	0.300	0.622	0.373
HK-2B	0.40	300'	0.067	0.448	1300'	0.055	3.80	0.095	1300'	0.072	0.615	0.369
HKT-3A	0.40	300'	0.040	0.366	250'	0.067	4.20	0.017	1400'	0.078	0.461	0.277
HKT-3B	0.24	300'	0.100	0.254	1600'	0.053	3.70	0.120	1600'	0.089	0.463	0.278
HKT-3C	0.40	300'	0.025	0.665	1400'	0.058	3.90	0.100	2900'	0.161	0.926	0.556
HKT-3D	0.40	300'	0.133	0.341	2700'	0.033	2.95	0.254	0'	0	0.595	0.357
HKT-3E	0.24	300'	0.100	0.254	800'	0.067	4.20	0.053	700'	0.039	0.346	0.208
HKT-3F	0.24	300'	0.025	0.442	400'	0.033	2.95	0.038	3650'	0.203	0.683	0.410
HKT-3G	0.24	300'	0.033	0.395	3700'	0.023	2.45	0.420	0'	0	0.815	0.489
HKT-3H	0.24	300'	0.033	0.395	1200'	0.050	3.60	0.093	2100'	0.117	0.605	0.363
HK-3A	0.24	300'	0.050	0.335	2350'	0.027	2.65	0.246	0'	0	0.581	0.349
HK-3B	0.24	300'	0.020	0.483	2850'	0.017	2.10	0.377	600'	0.033	0.893	0.536
LDB-1	0.40	300'	0.200	0.289	1900'	0.061	4.00	0.132	10100'	0.561	0.982	0.589
HK-3C	0.24	300'	0.033	0.395	2000'	0.035	3.00	0.185	1250'	0.069	0.649	0.389
HKT-4	0.40	300'	0.100	0.382	1350'	0.041	3.25	0.115	16600'	0.922	1.419	0.851
HKT-5A	0.24	300'	0.050	0.335	300'	0.067	4.20	0.20	1800'	0.100	0.455	0.273
HKT-5B	0.40	300'	0.100	0.382	900'	0.057	4.40	0.057	2400'	0.133	0.572	0.343
HK-4A	0.40	300'	0.057	0.478	600'	0.083	4.65	0.036	1500'	0.083	0.597	0.358
HKT-6A	0.24	300'	0.020	0.483	900'	0.040	3.25	0.077	1400'	0.078	0.638	0.383
HKT-6B	0.24	300'	0.050	0.335	2400'	0.035	3.00	0.222	0'	0	0.557	0.334
HKT-6C	0.40	300'	0.050	0.504	2050'	0.030	2.80	0.203	900'	0.050	0.757	0.454
HKT-6D	0.24	300'	0.050	0.335	2100'	0.029	2.75	0.212	0'	0	0.542	0.328
HKT-6E	0.24	300'	0.050	0.335	400'	0.050	3.60	0.031	3200'	0.178	0.544	0.326
HKT-6F	0.24	300'	0.100	0.254	500'	0.086	4.75	0.029	1700'	0.094	0.377	0.226
HKT-6G	0.24	300'	0.033	0.395	1650'	0.043	3.35	0.137	2650'	0.147	0.679	0.407

A-57

TABLE A-4 (Cont'd)

Sub-Area	Sheet Flow				Shallow Concentrated Flow				Channel Flow		Tc (hrs)	SCS Lag Time (0.6 Tc) (hrs)
	"n"	Length (ft)	Slope (ft/ft)	Time (hrs)	Length (ft)	Slope (ft/ft)	Velocity (ft/sec)	Time (hrs)	Length (ft)	Time (hrs)		
HK-4B	0.24	300'	0.011	0.613	2550'	0.028	2.70	0.262	0'	0	0.875	0.525
HKT-7A	0.24	300'	0.033	0.395	550'	0.050	3.60	0.042	1900'	0.106	0.543	0.326
HKT-7B	0.24	300'	0.029	0.416	2100'	0.023	2.45	0.238	0'	0	0.654	0.392
HKT-7C	0.40	300'	0.033	0.595	1100'	0.036	3.05	0.100	1700'	0.094	0.789	0.473
HKT-7D	0.24	300'	0.040	0.366	2150'	0.033	2.95	0.202	0'	0	0.568	0.371
HKT-7E	0.40	300'	0.075	0.428	1200'	0.033	2.95	0.113	1400'	0.078	0.619	0.371
HK-4C	0.24	300'	0.009	0.665	3700'	0.021	2.35	0.437	0'	0	1.102	0.661
HK-4D	0.24	300'	0.020	0.483	2100'	0.040	3.25	0.179	750'	0.042	0.704	0.422
HK-4E	0.24	300'	0.050	0.335	3100'	0.023	2.45	0.351	600'	0.033	0.719	0.431
HKT-8	0.24	300'	0.011	0.613	2500'	0.021	2.35	0.296	9800'	0.544	1.453	0.872
HK-5A	0.24	300'	0.050	0.335	2650'	0.033	2.95	0.250	1400'	0.078	0.663	0.398
HKT-9	0.24	300'	0.020	0.483	400'	0.030	2.80	0.040	7100'	0.394	0.917	0.550
HK-5B	0.24	300'	0.025	0.442	3300'	0.031	2.85	0.322	1000'	0.056	0.820	0.492
HKT-10	0.24	300'	0.017	0.515	2650'	0.025	2.55	0.289	4900'	0.272	1.076	0.646
HK-4C	0.24	300'	0.010	0.637	2750'	0.035	3.00	0.255	1000'	0.056	0.948	0.569
HKT-11A	0.24	300'	0.010	0.637	200'	0.010	1.60	0.035	2300'	0.128	0.800	0.480
HKT-11B	0.24	300'	0.013	0.574	1700'	0.042	3.30	0.143	1550'	0.086	0.803	0.482
HKT-11C	0.24	300'	0.010	0.637	1500'	0.050	3.60	0.116	2000'	0.111	0.864	0.518
HKT-11D	0.24	300'	0.040	0.366	150'	0.040	3.25	0.013	3800'	0.211	0.590	0.354
HKT-11E	0.24	300'	0.033	0.395	4100'	0.016	2.05	0.556	0'	0	0.951	0.571
HKT-11F	0.24	300'	0.013	0.574	2800'	0.032	2.90	0.268	800'	0.044	0.886	0.532
HKT-11G	0.24	300'	0.020	0.483	350'	0.038	3.15	0.075	3400'	0.189	0.747	0.448
HKT-11H	0.24	300'	0.013	0.574	600'	0.028	2.70	0.062	950'	0.053	0.689	0.413
HKT-11I	0.24	300'	0.057	0.318	2050'	0.038	3.15	0.181	1200'	0.067	0.566	0.340
HKT-11J	0.24	300'	0.010	0.637	550'	0.057	3.85	0.040	1900'	0.106	0.783	0.470
HKT-11K	0.24	300'	0.025	0.442	1000'	0.055	3.80	0.073	2500'	0.139	0.654	0.392
HKT-11L	0.24	300'	0.100	0.254	1100'	0.070	4.25	0.072	1250'	0.070	0.396	0.238
HKT-11M	0.24	300'	0.050	0.335	700'	0.038	3.15	0.062	4000'	0.222	0.619	0.371
HKT-11N	0.24	300'	0.020	0.483	400'	0.043	3.35	0.033	3600'	0.200	0.716	0.430
HKT-11O	0.24	300'	0.014	0.557	3800'	0.023	2.45	0.431	1250'	0.070	1.058	0.635
HKT-11P	0.24	300'	0.025	0.442	3600'	0.030	2.80	0.357	2200'	0.122	0.921	0.553
HK-6A	0.24	300'	0.033	0.395	1500'	0.012	1.80	0.231	0'	0	0.626	0.376
HKT-12	0.24	300'	0.008	0.697	950'	0.067	4.20	0.063	2800'	0.156	0.916	0.550

A-58

TABLE A-4 (Cont'd)

Sub-Area	Sheet Flow				Shallow Concentrated Flow				Channel Flow		Tc (hrs)	SCS Lag Time (0.6 Tc) (hrs)
	"n"	Length (ft)	Slope (ft/ft)	Time (hrs)	Length (ft)	Slope (ft/ft)	Velocity (ft/sec)	Time (hrs)	Length (ft)	Time (hrs)		
HK-6B	0.40	300'	0.100	0.382	2700'	0.026	2.60	0.288	1700'	0.094	0.764	0.458
HKT-13	0.24	300'	0.050	0.335	200'	0.050	3.60	0.015	6800'	0.378	0.728	0.437
HKT-14A	0.24	150'	0.009	0.382	1500'	0.019	2.20	0.189	1500'	0.083	0.654	0.392
HKT-14B	0.011	150'	0.010	0.031	2900'	0.022	2.40	0.336	200'	0.011	0.378	0.227
HKT-14C	0.24	300'	0.017	0.515	1300'	0.042	3.30	0.109	600'	0.033	0.657	0.394
HKT-14D	0.24	300'	0.033	0.395	800'	0.067	4.20	0.053	1400'	0.078	0.526	0.316
HKT-14E	0.24	300'	0.080	0.277	1400'	0.036	3.05	0.128	1600'	0.089	0.494	0.296
HKT-14F	0.24	300'	0.100	0.254	1900'	0.038	3.15	0.168	2700'	0.150	0.572	0.343
HKT-14G	0.011	150'	0.033	0.019	2600'	0.020	2.30	0.314	0'	0	0.333	0.200
HKT-14H	0.24	300'	0.033	0.395	200'	0.029	2.75	0.020	2100'	0.117	0.532	0.319
HKT-14I	0.24	300'	0.020	0.483	1400'	0.033	2.95	0.132	1500'	0.083	0.698	0.419
HKT-14J	0.24	300'	0.020	0.483	2800'	0.041	3.25	0.239	0'	0	0.722	0.433
HKT-14K	0.24	300'	0.008	0.697	1700'	0.037	3.10	0.152	2100'	0.117	0.966	0.580
HKT-14L	0.40	300'	0.033	0.595	500'	0.020	2.30	0.060	3000'	0.167	0.822	0.493
HKT-14M	0.24	300'	0.020	0.483	100'	0.067	4.20	0.007	2500'	0.139	0.629	0.377
HKT-14N	0.24	300'	0.100	0.254	1300'	0.038	3.15	0.115	3000'	0.167	0.536	0.322
HKT-14O	0.40	300'	0.067	0.448	1700'	0.050	3.60	0.131	2300'	0.128	0.707	0.424
HK-7A	0.24	300'	0.033	0.395	3000'	0.026	2.60	0.321	0'	0	0.716	0.430
HK-7B	0.24	300'	0.100	0.254	2100'	0.026	2.60	0.224	0'	0	0.478	0.287
HK-7C	0.24	300'	0.033	0.395	2900'	0.021	2.35	0.343	200'	0.011	0.749	0.449
HK-7D	0.24	300'	0.025	0.442	2200'	0.025	2.55	0.240	2100'	0.117	0.799	0.479
HKT-15	0.24	300'	0.007	0.735	1800'	0.036	3.05	0.164	5800'	0.322	1.221	0.733
HKT-16	0.40	300'	0.016	0.795	1700'	0.033	2.95	0.160	4600'	0.256	1.211	0.727
HK-8	0.24	300'	0.020	0.483	3300'	0.028	2.70	0.340	3300'	0.183	1.006	0.604
HK-9	0.24	300'	0.018	0.504	2500'	0.032	2.90	0.239	3700'	0.206	0.949	0.569
HKT-17A	0.24	300'	0.013	0.574	2100'	0.025	2.55	0.229	600'	0.033	0.836	0.502
HKT-17B	0.24	300'	0.033	0.395	1150'	0.052	3.70	0.086	700'	0.039	0.520	0.312
HKT-17C	0.40	300'	0.029	0.626	3000'	0.032	2.90	0.287	0'	0	0.913	0.548
HKT-17D	0.24	300'	0.020	0.483	1000'	0.022	2.40	0.116	2400'	0.133	0.732	0.439
HKT-17E	0.24	300'	0.020	0.483	500'	0.029	2.75	0.051	1550'	0.086	0.620	0.372
HKT-17F	0.24	300'	0.022	0.465	600'	0.031	2.85	0.058	3400'	0.189	0.712	0.427
HKT-17G	0.24	300'	0.050	0.335	1400'	0.040	3.25	0.120	2900'	0.161	0.616	0.370
HKT-18	0.24	100'	0.010	0.637	100'	0.010	1.60	0.017	5300'	0.294	0.948	0.569

A-59

TABLE A-4 (Concluded)

Sub-Area	Sheet Flow			Shallow Concentrated Flow				Channel Flow		Tc (hrs)	SCS Lag Time (0.6 Tc) (hrs)	
	"n"	Length (ft)	Slope (ft/ft)	Time (hrs)	Length (ft)	Slope (ft/ft)	Velocity (ft/sec)	Time (hrs)	Length (ft)			Time (hrs)
HKT-19	0.24	300'	0.005	0.841	700'	0.005	1.15	0.169	5600'	0.311	1.321	0.793
HKT-10	0.40	300'	0.033	0.595	1700'	0.023	2.45	0.193	7300'	0.406	1.194	0.716

- Notes:
- 1) "n" = sheet flow roughness factor (dimensionless)
 - 2) Channel flow calculated at 5 feet per second
 - 3) Tc = Time of Concentration

A-60

TABLE A-5
CITY OF LONGVIEW MASTER DRAINAGE STUDY
Eastman Lake Creek Watershed Curve Numbers and Percent Impervious (Existing Conditions)

Sub-Area	Total Area	Hydrologic Soil Group	Land Use	Area	% Total Area	Curve Number	Composite Curve Number	Composite Curve Number	Average Curve Number	Percent Impervious	Composite Percent Impervious
	(acres)			(acres)			(ANC II)	(ANC III)			
1	119	B	SFR	28	24	75	69.9	84.9	72.9	25	12.0
		B	UNDEV	63	53	65				8	
		C	UNDEV	28	24	76				8	
2	119	B	SFR	19	16	75	68.3	84.0	71.4	25	12.2
		B	MF, MH	3	3	85				65	
		B	UNDEV	84	71	65				8	
		C	UNDEV	13	11	76				8	
3	113	B	C, PU	3	3	92	72.8	86.8	75.6	80	9.9
		B	UNDEV	37	33	65				8	
		C	UNDEV	73	65	76				8	
4	75	B	UNDEV	39	52	65	70.3	85.3	73.3	8	8.0
		C	UNDEV	36	48	76				8	
5	56	B	UNDEV	28	50	65	70.5	85.5	73.5	8	8.0
		C	UNDEV	28	50	76				8	
6	97	B	SFR	21	22	75	75.3	88.3	77.9	38	15.4
		C	SFR	3	3	83				38	
		B	UNDEV	6	6	65				8	
		C	UNDEV	67	69	76				8	
7	56	B	SFR	18	32	75	73.4	87.4	76.2	38	19.8
		C	SFR	4	7	83				38	
		B	UNDEV	14	25	65				8	
		C	UNDEV	20	36	76				8	
8	149	B	SFR	21	14	75	76.9	89.0	79.3	38	18.5
		C	SFR	31	21	83				38	
		B	UNDEV	6	4	65				8	
		C	UNDEV	91	61	76				8	
9	90	B	SFR	28	31	75	68.1	84.0	71.3	38	17.3
		B	UNDEV	62	69	65				8	
10	56	B	SFR	36	64	75	71.4	86.0	74.3	38	27.3
		B	UNDEV	20	36	65				8	
11	64	B	SFR	10	16	75	74.0	88.0	76.8	38	12.7
		B	UNDEV	11	17	65				8	
		C	UNDEV	43	67	76				8	

TABLE A-5 (cont'd)

CITY OF LONGVIEW MASTER DRAINAGE STUDY
 Eastman Lake Creek Watershed Curve Numbers and Percent Impervious (Existing Conditions)

Sub-Area	Total Area	Hydrologic Soil Group	Land Use	Area	% Total Area	Curve Number	Composite Curve Number	Composite Curve Number	Average Curve Number	Percent Impervious	Composite Percent Impervious
	(acres)			(acres)			(AMC II)	(AMC III)			
12	110	B	SFR	5	5	75	74.8	88.0	77.4	38	9.7
		B	UNDEV	46	42	65				8	
		C	UNDEV	64	58	76				8	
13	164	B	SFR	6	4	75	77.3	89.3	79.7	38	19.0
		C	SFR	54	33	83				38	
		B	UNDEV	15	9	65				8	
		C	UNDEV	89	54	76				8	
14	303	B	SFR	8	3	75	75.0	88.0	77.6	38	14.5
		B	C,PU	8	3	92				80	
		C	C,PU	14	5	94				80	
		B	P	9	3	69				25	
		B	UNDEV	57	19	65				8	
		C	UNDEV	207	68	76				8	
15	103	B	SFR	21	20	75	78.1	90.1	80.5	38	39.6
		C	SFR	78	76	83				38	
		B	C,PU	4	4	92				80	
16	218	B	SFR	72	33	75	78.3	90.3	80.7	38	25.7
		C	SFR	28	13	83				38	
		C	MF,MH	3	1	94				65	
		B	C,PU	7	3	92				80	
		C	C,PU	2	1	94				80	
		B	UNDEV	19	9	65				8	
		C	UNDEV	92	42	76				8	
14A	73	C	I	14	19	91	76.2	89.0	78.7	38	61.6
		B	UNDEV	18	25	65				38	
		C	UNDEV	41	56	76				80	
16A	72	B	SFR	13	18	75	89.8	96.0	91.1	38	27.9
		B	C,PU	13	18	92				80	
		B	UNDEV	17	24	65				8	
		C	UNDEV	42	58	76				8	
17	105	C	I	72	69	91	85.6	94.0	87.2	72	51.9
		B	UNDEV	7	7	65				8	
		C	UNDEV	26	25	76				8	

TABLE A-5 (cont'd)
 CITY OF LONGVIEW MASTER DRAINAGE STUDY
 Eastman Lake Creek Watershed Curve Numbers and Percent Impervious (Existing Conditions)

Sub- Area	Total Area	Hydrologic Soil Group	Land Use	Area	% Total Area	Curve Number	Composite Curve Number	Composite Curve Number	Average Curve Number	Percent Impervious	Composite Percent Impervious
	(acres)			(acres)			(ANC II)	(ANC III)			
18	115	B	I	9	8	88	77.0	89.0	79.4	72	24.1
		C	I	20	17	91				72	
		B	UNDEV	27	23	65				8	
		C	UNDEV	59	51	76				8	
19	253	B	SFR	6	2	75	75.6	88.6	78.2	38	17.3
		B	C,PU	5	2	92				80	
		C	I	14	6	91				72	
		C	P	51	20	79				25	
		B	UNDEV	91	36	65				8	
		C	UNDEV	92	36	76				8	
20	131	B	SFR	28	21	75	80.1	91.1	82.3	38	42.9
		B	C,PU	3	2	92				80	
		C	C,PU	16	12	94				80	
		C	I	37	28	91				72	
		B	UNDEV	30	23	65				8	
		C	UNDEV	17	13	76				8	
21	114	B	I	11	10	88	76.2	89.0	78.8	72	23.9
		C	I	16	14	91				72	
		C	P	5	4	79				25	
		B	UNDEV	33	29	65				8	
		C	UNDEV	49	43	76				8	
22	282	B	SFR	53	19	75	75.2	88.2	77.8	25	16.4
		C	SFR	4	1	83				25	
		B	P	83	29	79				25	
		B	UNDEV	40	14	65				8	
		C	UNDEV	102	36	76				8	
23	202	C	SFR	6	3	83	75.4	88.4	78.0	38	16.9
		B	UNDEV	93	46	65				8	
		C	UNDEV	92	46	76				8	
			LAKE	17	8	100				100	
24	14	B	SFR	3	21	75	81.3	92.0	83.4	38	38.0
		C	SFR	11	79	83				38	
25	284	B	MF,MH	5	2	85	71.2	86.0	74.2	65	16.4
		B	I	28	10	88				72	
		C	I	5	2	94				72	
		B	UNDEV	123	43	65				8	
		C	UNDEV	123	43	76				8	

TABLE A-5 (cont'd)

CITY OF LONGVIEW MASTER DRAINAGE STUDY
 Eastman Lake Creek Watershed Curve Numbers and Percent Impervious (Existing Conditions)

Sub-Area	Total Area	Hydrologic Soil Group	Land Use	Area	% Total Area	Curve Number	Composite Curve Number	Composite Curve Number	Average Curve Number	Percent Impervious	Composite Percent Impervious
	(acres)			(acres)			(ANC II)	(ANC III)			
26	253	B	SFR	6	2	75	78.4	90.4	80.8	38	20.4
		C	SFR	58	23	83					
		B	C,PU	9	4	92					
		C	C,PU	8	3	94					
		B	UNDEV	8	3	65					
		C	UNDEV	164	65	76					
27	226	B	SFR	85	38	75	83.4	93.0	85.3	38	53.3
		C	SFR	41	18	83					
		B	MF,MH	3	1	85					
		C	MF,MH	11	5	90					
		B	C,PU	38	17	92					
		C	C,PU	37	16	94					
		C	I	4	2	94					
		B	UNDEV	5	2	65					
C	UNDEV	2	1	76							
27A	146	B	SFR	51	35	75	75.4	88.4	78.0	38	26.7
		C	SFR	8	5	83					
		B	MF,MH	8	5	85					
		C	MF,MH	2	1	90					
		B	I	2	1	88					
		C	I	4	3	91					
		B	UNDEV	25	17	65					
		C	UNDEV	46	32	76					
28	27	C	UNDEV	27	100	76	76.0	89.0	78.6	8	8.0
29	86	B	SFR	19	22	75	71.7	86.0	74.5	25	11.8
		B	UNDEV	32	37	65					
		C	UNDEV	35	41	76					
30	45	B	UNDEV	17	38	65	71.8	86.0	74.7	8	8.0
		C	UNDEV	28	62	76					
31	52	B	UNDEV	10	19	65	73.9	87.9	76.7	8	8.0
		C	UNDEV	42	81	76					
32	99	B	SFR	22	22	75	77.2	89.2	79.6	38	34.0
		C	SFR	17	17	83					
		B	I	12	12	88					
		C	I	10	10	91					
		B	UNDEV	25	25	65					
		C	UNDEV	13	13	76					

TABLE A-5 (Concluded)

CITY OF LONGVIEW MASTER DRAINAGE STUDY
 Eastman Lake Creek Watershed Curve Numbers and Percent Impervious (Existing Conditions)

Sub-Area	Total Area (acres)	Hydrologic Soil Group	Land Use	Area (acres)	% Total Area	Curve Number	Composite Curve Number (ANC II)	Composite Curve Number (ANC III)	Average Curve Number	Percent Impervious	Composite Percent Impervious
33	182	B	SFR	27	15	75	75.4	88.4	78.0	38	28.0
		C	SFR	21	12	83				38	
		B	MF, MH	7	4	85				65	
		B	C, PU	21	12	92				80	
		C	C, PU	4	2	94				80	
		B	UNDEV	64	35	65				8	
		C	UNDEV	38	21	76				8	
33A	34	C	UNDEV	34	100	76	76.0	89.0	78.6	8	8.0
34	101	B	SFR	32	32	75	68.5	84.0	71.6	25	13.4
		B	UNDEV	66	65	65				8	
		C	UNDEV	3	3	76				8	
35	225	B	SFR	89	40	75	69.6	84.6	72.6	25	14.7
		B	UNDEV	123	55	65				8	
		C	UNDEV	13	6	76				8	
35A	118	B	UNDEV	84	71	65	68.2	84.0	71.3	8	8.0
		C	UNDEV	34	29	76				8	
36	103	B	UNDEV	56	54	65	70.0	85.0	73.0	8	8.0
		C	UNDEV	47	46	76				8	
37	107	B	SFR	85	79	75	72.8	86.8	75.6	38	37.4
		C	SFR	17	16	83				38	
		B	P	5	5	69				25	
38	105	B	SFR	17	16	75	72.9	86.9	75.7	38	22.5
		B	C, PU	5	5	92				80	
		C	C, PU	2	2	94				80	
		B	I	8	8	88				72	
		B	UNDEV	47	45	65				8	
		C	UNDEV	26	25	76				8	
39	265	B	SFR	25	9	75	70.1	85.1	73.1	38	15.4
		B	C, PU	17	6	92				80	
		B	UNDEV	164	62	65				8	
		C	UNDEV	59	22	76				8	
40	1043	B	I	176	17	88	82.0	92.0	84.0	72	47.3
		C	I	88	8	91				72	
		B	UNDEV	314	30	65				8	
		C	UNDEV	203	19	76				8	
			POND	262	25	100				100	

Note: Average Curve Number = $CNII + 0.2(CNIII - CNII)$

TABLE A-6
CITY OF LONGVIEW MASTER DRAINAGE STUDY
Eastman Lake Creek Watershed Curve Numbers
Fully Developed Watershed Conditions

Sub- Area	Total Area	Hydrologic Soil Group	Land Use	% Total Area		Curve Number	Composite Curve Number	Composite Curve Number	Average Curve Number
	(acres)			(acres)	(acres)		(AMC II)	(AMC III)	
1	119	B	SFR	28	24	79	80.6	91.6	82.8
		B	UNDEV	63	53	79			
		C	UNDEV	28	24	86			
2	119	B	SFR	19	16	79	79.9	91.0	82.1
		B	MF, MH	3	3	85			
		B	UNDEV	84	71	79			
		C	UNDEV	13	11	86			
3	113	B	C, PU	3	3	92	83.9	93.0	85.7
		B	UNDEV	37	33	79			
		C	UNDEV	73	65	86			
4	75	B	UNDEV	39	52	79	82.4	92.4	84.4
		C	UNDEV	36	48	86			
5	56	B	UNDEV	28	50	79	82.5	92.5	84.5
		C	UNDEV	28	50	86			
6	97	B	SFR	21	22	79	84.1	93.1	85.9
		C	SFR	3	3	86			
		B	UNDEV	6	6	79			
		C	UNDEV	67	69	86			
7	56	B	SFR	18	32	79	82.0	92.0	84.0
		C	SFR	4	7	86			
		B	UNDEV	14	25	79			
		C	UNDEV	20	36	86			
8	149	B	SFR	21	14	79	84.7	93.7	86.5
		C	SFR	31	21	86			
		B	UNDEV	6	4	79			
		C	UNDEV	91	61	86			
9	90	B	SFR	28	31	79	79.0	91.0	81.4
		B	UNDEV	62	69	79			
10	56	B	SFR	36	64	79	79.0	91.0	81.4
		B	UNDEV	20	36	79			
11	64	B	SFR	10	16	79	83.7	93.0	85.6
		B	UNDEV	11	17	79			
		C	UNDEV	43	67	86			

TABLE A-6 (cont'd)
 CITY OF LONGVIEW MASTER DRAINAGE STUDY
 Eastman Lake Creek Watershed Curve Numbers
 Fully Developed Watershed Conditions

Sub- Area	Total Area	Hydrologic Soil Group	Land Use	% Total Area	Curve Number	Composite Curve Number (AMC II)	Composite Curve Number (AMC III)	Average Curve Number	
----- (acres)		----- (acres)			----- (AMC II)		----- (AMC III)		
12	110	B	SFR	5	5	79	86.7	94.7	88.3
		B	UNDEV	46	42	79			
		C	UNDEV	64	58	86			
13	164	B	SFR	6	4	79	85.1	94.0	86.9
		C	SFR	54	33	86			
		B	UNDEV	15	9	79			
		C	UNDEV	89	54	86			
14	303	B	SFR	8	3	79	84.8	93.8	86.6
		B	C,PU	8	3	92			
		C	C,PU	14	5	94			
		B	P	9	3	79			
		B	UNDEV	57	19	79			
		C	UNDEV	207	68	86			
15	103	B	SFR	21	20	79	81.2	92.0	83.4
		C	SFR	78	76	86			
		B	C,PU	4	4	92			
16	218	B	SFR	72	33	79	85.4	94.0	87.1
		C	SFR	28	13	86			
		C	MF,MH	3	1	94			
		B	C,PU	7	3	92			
		C	C,PU	2	1	94			
		B	UNDEV	19	9	79			
		C	UNDEV	92	42	86			
14A	73	C	I	14	19	91	85.2	94.0	87.0
		B	UNDEV	18	25	79			
		C	UNDEV	41	56	86			
16A	72	B	SFR	13	18	79	84.2	93.2	86.0
		B	C,PU	13	18	92			
		B	UNDEV	17	24	79			
		C	UNDEV	29	40	86			
17	105	C	I	72	69	91	89.0	96.0	90.4
		B	UNDEV	7	7	79			
		C	UNDEV	26	25	86			

TABLE A-6 (cont'd)
 CITY OF LONGVIEW MASTER DRAINAGE STUDY
 Eastman Lake Creek Watershed Curve Numbers
 Fully Developed Watershed Conditions

Sub- Area	Total Area	Hydrologic Soil Group	Land Use	% Total Area		Curve Number	Composite Curve Number	Composite Curve Number	Average Curve Number
	(acres)			(acres)			(AMC II)	(AMC III)	
18	115	B	I	9	8	88	85.4	94.0	87.1
		C	I	20	17	91			
		B	UNDEV	27	23	79			
		C	UNDEV	59	51	86			
19	253	B	SFR	6	2	79	85.8	94.0	87.4
		B	C,PU	5	2	92			
		C	I	14	6	91			
		C	P	51	20	86			
		B	UNDEV	91	36	79			
		C	UNDEV	92	36	86			
20	131	B	SFR	28	21	79	85.4	94.0	87.1
		B	C,PU	3	2	92			
		C	C,PU	16	12	94			
		C	I	37	28	91			
		B	UNDEV	30	23	79			
		C	UNDEV	17	13	86			
21	114	B	I	11	10	88	84.9	93.9	86.7
		C	I	16	14	91			
		C	P	5	4	86			
		B	UNDEV	33	29	79			
		C	UNDEV	49	43	86			
22	282	B	SFR	53	19	79	81.6	92.0	83.7
		C	SFR	4	1	86			
		B	P	83	29	79			
		B	UNDEV	40	14	79			
		C	UNDEV	102	36	86			
23	202	C	SFR	6	3	86	86.5	94.5	88.1
		B	UNDEV	93	46	79			
		C	UNDEV	92	46	86			
			LAKE	17	8	100			
24	14	B	SFR	3	21	79	84.5	93.5	86.3
		C	SFR	11	79	86			
25	284	B	MF,MH	5	2	85	81.6	92.0	83.7
		B	I	28	10	88			
		C	I	5	2	94			
		B	UNDEV	123	43	79			
		C	UNDEV	123	43	86			

TABLE A-6 (Cont.)
 CITY OF LONGVIEW MASTER DRAINAGE STUDY
 Eastman Lake Creek Watershed Curve Numbers
 Fully Developed Watershed Conditions

Sub-Area	Total Area	Hydrologic Soil Group	Land Use	% Total Area	% Total Area	Curve Number	Composite Curve Number	Composite Curve Number	Average Curve Number
	(acres)			(acres)	(acres)		(AMC II)	(AMC III)	
26	253	B	SFR	6	2	79	86.1	94.1	87.7
		C	SFR	58	23	86			
		B	C,PU	9	4	92			
		C	C,PU	8	3	94			
		B	UNDEV	8	3	79			
		C	UNDEV	164	65	86			
27	226	B	SFR	85	38	79	85.9	94.0	87.5
		C	SFR	41	18	86			
		B	MF,MH	3	1	85			
		C	MF,MH	11	5	90			
		B	C,PU	38	17	92			
		C	C,PU	37	16	94			
		C	I	4	2	94			
		B	UNDEV	5	2	79			
C	UNDEV	2	1	86					
27A	146	B	SFR	51	35	79	82.5	92.5	84.5
		C	SFR	8	5	86			
		B	MF,MH	8	5	85			
		C	MF,MH	2	1	90			
		B	I	2	1	88			
		C	I	4	3	91			
		B	UNDEV	25	17	79			
		C	UNDEV	46	32	86			
28	27	C	UNDEV	27	100	86	86.0	94.0	87.6
29	86	B	SFR	19	22	79	81.8	92.0	83.9
		B	UNDEV	32	37	79			
		C	UNDEV	35	41	86			
30	45	B	UNDEV	17	38	79	83.4	93.0	85.3
		C	UNDEV	28	62	86			
31	52	B	UNDEV	10	19	79	84.7	93.7	86.5
		C	UNDEV	42	81	86			
32	99	B	SFR	22	22	79	83.4	93.0	85.3
		C	SFR	17	17	86			
		B	I	12	12	88			
		C	I	10	10	91			
		B	UNDEV	25	25	79			
		C	UNDEV	13	13	86			

TABLE A-6 (cont'd)

CITY OF LONGVIEW MASTER DRAINAGE STUDY
 Eastman Lake Creek Watershed Curve Numbers
 Fully Developed Watershed Conditions

Sub- Area	Total Area	Hydrologic Soil Group	Land Use	% Total Area	% Total Area	Curve Number	Composite Curve Number (AMC II)	Composite Curve Number (AMC III)	Average Curve Number
----- (acres)		----- (acres)		----- (acres)		----- (AMC II)		----- (AMC III)	
33	182	B	SFR	27	15	79	83.3	93.0	85.3
		C	SFR	21	12	86			
		B	MF,MH	7	4	85			
		B	C,PU	21	12	92			
		C	C,PU	4	2	94			
		B	UNDEV	64	35	79			
		C	UNDEV	38	21	86			
33A	34	C	UNDEV	34	100	86	86.0	94.0	87.6
34	101	B	SFR	32	32	79	79.2	91.0	81.6
		B	UNDEV	66	65	79			
		C	UNDEV	3	3	86			
35	225	B	SFR	89	40	79	79.4	91.0	81.7
		B	UNDEV	123	55	79			
		C	UNDEV	13	6	86			
35A	118	B	UNDEV	84	71	79	81.0	92.0	83.2
		C	UNDEV	34	29	86			
36	103	B	UNDEV	56	54	79	82.2	92.2	84.2
		C	UNDEV	47	46	86			
37	107	B	SFR	85	79	79	76.4	89.0	78.9
		C	SFR	17	16	86			
		B	P	5	5	79			
38	105	B	SFR	17	16	79	82.3	92.3	84.3
		B	C,PU	5	5	92			
		C	C,PU	2	2	94			
		B	I	8	8	88			
		B	UNDEV	47	45	79			
		C	UNDEV	26	25	86			
39	265	B	SFR	25	9	79	81.4	92.0	83.5
		B	C,PU	17	6	92			
		B	UNDEV	164	62	79			
		C	UNDEV	59	22	86			
40	1043	B	I	176	17	88	88.2	95.2	89.6
		C	I	88	8	91			
		B	UNDEV	314	30	79			
		C	UNDEV	203	19	86			
			POND	262	25	100			

Note: Average Curve Number = $CN_{II} + 0.2(CN_{III} - CN_{II})$

TABLE A-6 (concluded)

Hydrologic Soil Group	Fully Developed Conditions Minimum SCS Curve Number (C=0.70)
-----	-----
A	68
B	79
C	86
D	89

TABLE A-7
CITY OF LONGVIEW MASTER DRAINAGE STUDY
Eastman Lake Creek Watershed Time-of-Concentration (Existing Conditions)

Sub- Area	Drainage Area	n	Sheet Flow			Shallow Concentrated Flow - Paved				Shallow Concentrated Flow - Unpaved				Pipe or Channel Flow			SCS Lag
			L	S	TT	L	S	V	TT	L	S	V	TT	L	TT	TC	
	(acres)	(Mann- ing's)	(ft)	(ft/ft)	(hrs)	(ft)	(ft/ft)	(fps)	(hrs)	(ft)	(ft/ft)	(fps)	(hrs)	(ft)	(hrs)	(hrs)	(hrs)
1	119	0.04	300	0.037	0.09	NA	NA	NA	NA	550	0.027	2.5	0.06	2850	0.16	0.31	0.19
2	119	0.04	350	0.046	0.09	NA	NA	NA	NA	1300	0.015	1.9	0.19	2800	0.16	0.44	0.26
3	113	0.04	250	0.036	0.08	NA	NA	NA	NA	800	0.044	3.2	0.07	2800	0.16	0.31	0.19
4	75	0.04	200	0.030	0.07	NA	NA	NA	NA	550	0.036	2.9	0.05	2900	0.16	0.28	0.17
5	56	0.04	200	0.030	0.07	NA	NA	NA	NA	700	0.029	2.6	0.07	2100	0.12	0.26	0.16
6	97	0.04	350	0.029	0.11	NA	NA	NA	NA	900	0.039	3.0	0.08	1300	0.07	0.26	0.16
7	56	0.04	250	0.024	0.09	NA	NA	NA	NA	800	0.044	3.2	0.07	1900	0.11	0.27	0.16
8	149	0.04	300	0.033	0.09	NA	NA	NA	NA	600	0.047	3.3	0.05	3700	0.21	0.35	0.21
9	90	0.04	200	0.050	0.06	NA	NA	NA	NA	1100	0.027	2.5	0.12	1100	0.06	0.24	0.14
10	56	0.04	100	0.030	0.04	NA	NA	NA	NA	600	0.047	3.3	0.05	2300	0.13	0.22	0.13
11	64	0.04	200	0.030	0.07	NA	NA	NA	NA	550	0.047	3.3	0.05	1900	0.11	0.23	0.14
12	110	0.04	200	0.040	0.06	NA	NA	NA	NA	800	0.038	3.0	0.07	2000	0.11	0.24	0.14
13	164	0.04	200	0.040	0.06	NA	NA	NA	NA	900	0.030	2.6	0.10	3500	0.19	0.35	0.21
14	303	0.04	300	0.033	0.09	NA	NA	NA	NA	1500	0.040	3.0	0.14	3500	0.19	0.42	0.25
15	103	0.04	300	0.020	0.12	NA	NA	NA	NA	1500	0.020	2.1	0.20	1950	0.11	0.43	0.26
16	218	0.04	250	0.012	0.12	1200	0.021	2.9	0.11	NA	NA	NA	NA	3000	0.17	0.40	0.24
16A	72	0.04	300	0.020	0.12	550	0.015	2.5	0.06	NA	NA	NA	NA	4700	0.26	0.44	0.26
14A	73	NA	NA	NA	NA	NA	NA	NA	NA	NA	NA	NA	NA	3400	0.19	0.19	0.11
17	105	0.04	200	0.040	0.06	NA	NA	NA	NA	2100	0.019	2.1	0.28	1300	0.07	0.41	0.25
18	115	0.04	250	0.060	0.06	NA	NA	NA	NA	500	0.062	3.7	0.04	3600	0.20	0.30	0.18
19	253	0.04	300	0.033	0.09	NA	NA	NA	NA	500	0.040	3.0	0.05	4400	0.24	0.38	0.23
20	131	0.04	250	0.028	0.09	1000	0.02	2.9	0.10	200	0.075	4.1	0.01	2600	0.14	0.34	0.20
21	114	0.04	300	0.050	0.08	NA	NA	NA	NA	1200	0.041	3.1	0.11	3000	0.17	0.36	0.22
22	282	0.04	200	0.055	0.06	NA	NA	NA	NA	3500	0.031	2.7	0.36	3100	0.17	0.59	0.35
23	202	0.04	300	0.053	0.08	NA	NA	NA	NA	1200	0.041	3.1	0.11	1700	0.09	0.28	0.17
24	14	0.04	250	0.100	0.05	NA	NA	NA	NA	350	0.086	4.5	0.02	600	0.03	0.10	0.06
25	284	0.04	300	0.050	0.08	NA	NA	NA	NA	3000	0.030	2.6	0.32	2800	0.16	0.56	0.34
26	102	0.04	250	0.032	0.08	NA	NA	NA	NA	750	0.027	2.5	0.08	1100	0.06	0.22	0.13
27	226	0.04	150	0.080	0.04	700	0.036	3.8	0.05	750	0.029	2.6	0.08	3500	0.19	0.36	0.22
27A	146	0.04	300	0.037	0.09	900	0.017	2.6	0.10	NA	NA	NA	NA	3950	0.22	0.41	0.25
28	27	0.04	200	0.030	0.07	NA	NA	NA	NA	400	0.038	3.0	0.04	1400	0.08	0.19	0.11
29	86	0.04	300	0.123	0.06	NA	NA	NA	NA	1200	0.050	3.4	0.10	1200	0.07	0.23	0.14
30	45	0.04	300	0.050	0.08	NA	NA	NA	NA	1400	0.038	3.0	0.13	400	0.02	0.23	0.14
31	52	0.04	200	0.025	0.08	NA	NA	NA	NA	400	0.013	1.7	0.07	2800	0.16	0.31	0.19
32	99	0.04	250	0.024	0.09	NA	NA	NA	NA	1800	0.014	1.8	0.28	1700	0.09	0.46	0.28
33	182	0.04	300	0.017	0.12	NA	NA	NA	NA	1500	0.025	2.4	0.17	4400	0.24	0.53	0.32
33A	34	0.04	300	0.033	0.09	NA	NA	NA	NA	1100	0.011	1.6	0.19	1300	0.07	0.35	0.21
34	101	0.04	200	0.025	0.08	NA	NA	NA	NA	1000	0.020	2.1	0.13	1900	0.11	0.32	0.19
35	225	0.04	300	0.067	0.07	NA	NA	NA	NA	1900	0.050	3.4	0.16	3400	0.19	0.42	0.25
35A	118	0.04	250	0.020	0.10	NA	NA	NA	NA	3000	0.013	1.7	0.49	1300	0.07	0.66	0.40

TABLE A-7 (concluded)

Eastman Lake Creek Watershed Time-of-Concentration (Existing Conditions)

Sub-Area	Drainage Area	Sheet Flow				Shallow Concentrated Flow - Paved				Shallow Concentrated Flow - Unpaved				Pipe or Channel Flow			SCS Lag
		(acres)	n	L (ft)	S (ft/ft)	TT (hrs)	L (ft)	S (ft/ft)	V (fps)	TT (hrs)	L (ft)	S (ft/ft)	V (fps)	TT (hrs)	L (ft)	TT (hrs)	
36	103	0.04	250	0.024	0.09	NA	NA	NA	NA	2900	0.021	2.2	0.37	1100	0.06	0.52	0.31
37	107	0.04	200	0.005	0.15	550	0.018	2.7	0.06	850	0.011	1.6	0.15	2100	0.12	0.48	0.29
38	105	0.04	250	0.040	0.08	1900	0.008	1.9	0.28	NA	NA	NA	NA	1900	0.11	0.47	0.28
39	265	0.04	300	0.050	0.08	NA	NA	NA	NA	1400	0.021	2.2	0.18	1700	0.09	0.35	0.21
40	1043	0.04	300	0.030	0.10	NA	NA	NA	NA	2600	0.017	2.0	0.36	11500	0.20	0.66	0.40
Total	6603																

Notes

- Sheet Flow Travel Time computed as follows:
 $TT = (0.007 * (nL)^{0.8}) / (P2^{0.5} * S^{0.4})$ where P2 = 2-Yr/24-Hr rainfall in inches = 4.5
- Shallow Concentrated Flow (Paved & Unpaved) Travel Time computed as follows:
 $TT = L / (3600 * V)$ where V = flow velocity in fps based on land slope and Figure 3.1, USDA, 1986
- Pipe or Channel Flow Travel Time computed as follows:
 $TT = L / (3600 * V)$ where V = 5 fps average flow velocity in pipes or channels
- Time-of-Concentration computed as follows:
 TC = summation of travel times computed in 1., 2., and 3. above
- SCS Lag = 0.6 TC

TABLE A-8
 CITY OF LONGVIEW MASTER DRAINAGE STUDY
 Eastman Lake Creek Watershed Time-of-Concentration
 Fully Developed Watershed Conditions

Sub- Area	Drainage Area	Sheet Flow				Shallow Concentrated Flow - Paved				Shallow Concentrated Flow - Unpaved				Pipe or Channel Flow			SCS Lag
		n	L	S	TT	L	S	V	TT	L	S	V	TT	L	TT	TC	
	(acres)	(Mann- ing's)	(ft)	(ft/ft)	(hrs)	(ft)	(ft/ft)	(fps)	(hrs)	(ft)	(ft/ft)	(fps)	(hrs)	(ft)	(hrs)	(hrs)	(hrs)
1	119	0.04	300	0.037	0.09	550	0.027	3.4	0.04	NA	NA	NA	NA	2850	0.16	0.29	0.17
2	119	0.04	350	0.046	0.09	1300	0.015	2.5	0.14	NA	NA	NA	NA	2800	0.16	0.39	0.23
3	113	0.04	250	0.036	0.08	800	0.044	4.3	0.05	NA	NA	NA	NA	2800	0.16	0.29	0.17
4	75	0.04	200	0.030	0.07	550	0.036	3.9	0.04	NA	NA	NA	NA	2900	0.16	0.27	0.16
5	56	0.04	200	0.030	0.07	700	0.029	3.5	0.06	NA	NA	NA	NA	2100	0.12	0.25	0.15
6	97	0.04	350	0.029	0.11	900	0.039	4.0	0.06	NA	NA	NA	NA	1300	0.07	0.24	0.14
7	56	0.04	250	0.024	0.09	800	0.044	4.3	0.05	NA	NA	NA	NA	1900	0.11	0.25	0.15
8	149	0.04	300	0.033	0.09	600	0.047	4.4	0.04	NA	NA	NA	NA	3700	0.21	0.34	0.20
9	90	0.04	200	0.050	0.06	1100	0.027	3.4	0.09	NA	NA	NA	NA	1100	0.06	0.21	0.13
10	56	0.04	100	0.030	0.04	600	0.047	4.4	0.04	NA	NA	NA	NA	2300	0.13	0.21	0.13
11	64	0.04	200	0.030	0.07	550	0.047	4.4	0.03	NA	NA	NA	NA	1900	0.11	0.21	0.13
12	110	0.04	200	0.040	0.06	800	0.038	4.0	0.06	NA	NA	NA	NA	2000	0.11	0.23	0.14
13	164	0.04	200	0.040	0.06	900	0.030	3.5	0.07	NA	NA	NA	NA	3500	0.19	0.32	0.19
14	303	0.04	300	0.033	0.09	1500	0.040	4.1	0.10	NA	NA	NA	NA	3500	0.19	0.38	0.23
15	103	0.04	300	0.020	0.12	1500	0.020	2.9	0.14	NA	NA	NA	NA	1950	0.11	0.37	0.22
16	218	0.04	250	0.012	0.12	1200	0.021	2.9	0.11	NA	NA	NA	NA	3000	0.17	0.40	0.24
16A	72	0.04	300	0.020	0.12	550	0.015	2.5	0.06	NA	NA	NA	NA	4700	0.26	0.44	0.26
14A	73	NA	NA	NA	NA	NA	NA	NA	NA	NA	NA	NA	NA	3400	0.19	0.19	0.11
17	105	0.04	200	0.040	0.06	2100	0.019	2.8	0.21	NA	NA	NA	NA	1300	0.07	0.34	0.20
18	115	0.04	250	0.060	0.06	500	0.062	5.1	0.03	NA	NA	NA	NA	3600	0.20	0.29	0.17
19	253	0.04	300	0.033	0.09	500	0.040	4.1	0.03	NA	NA	NA	NA	4400	0.24	0.36	0.22
20	131	0.04	250	0.028	0.09	1000	0.020	2.9	0.10	200	0.075	4.1	0.01	2600	0.14	0.34	0.20
21	114	0.04	300	0.050	0.08	1200	0.041	4.1	0.08	NA	NA	NA	NA	3000	0.17	0.33	0.20
22	282	0.04	200	0.055	0.06	3500	0.031	3.6	0.27	NA	NA	NA	NA	3100	0.17	0.50	0.30
23	202	0.04	300	0.053	0.08	1200	0.041	4.1	0.08	NA	NA	NA	NA	1700	0.09	0.25	0.15
24	14	0.04	250	0.100	0.05	350	0.086	6.0	0.02	NA	NA	NA	NA	600	0.03	0.10	0.06
25	284	0.04	300	0.050	0.08	3000	0.030	3.5	0.24	NA	NA	NA	NA	2800	0.16	0.48	0.29
26	102	0.04	250	0.032	0.08	750	0.027	3.3	0.06	NA	NA	NA	NA	1100	0.06	0.20	0.12
27	226	0.04	150	0.080	0.04	700	0.036	3.8	0.05	750	0.029	2.6	0.08	3500	0.19	0.36	0.22
27A	146	0.04	300	0.037	0.09	900	0.017	2.6	0.10	NA	NA	NA	NA	3950	0.22	0.41	0.25
28	27	0.04	200	0.030	0.07	400	0.038	4.0	0.03	NA	NA	NA	NA	1400	0.08	0.18	0.11
29	86	0.04	300	0.123	0.06	1200	0.050	4.5	0.07	NA	NA	NA	NA	1200	0.07	0.20	0.12
30	45	0.04	300	0.050	0.08	1400	0.038	4.0	0.10	NA	NA	NA	NA	400	0.02	0.20	0.12
31	52	0.04	200	0.025	0.08	400	0.013	2.3	0.05	NA	NA	NA	NA	2800	0.16	0.29	0.17
32	99	0.04	250	0.024	0.09	1800	0.014	2.4	0.21	NA	NA	NA	NA	1700	0.09	0.39	0.23
33	182	0.04	300	0.017	0.12	1500	0.025	3.2	0.13	NA	NA	NA	NA	4400	0.24	0.49	0.29
33A	34	0.04	300	0.033	0.09	1100	0.011	2.1	0.15	NA	NA	NA	NA	1300	0.07	0.31	0.19
34	101	0.04	200	0.025	0.08	1000	0.020	2.9	0.10	NA	NA	NA	NA	1900	0.11	0.29	0.17
35	225	0.04	300	0.067	0.07	1900	0.050	4.5	0.12	NA	NA	NA	NA	3400	0.19	0.38	0.23
35A	118	0.04	250	0.020	0.10	3000	0.013	2.3	0.36	NA	NA	NA	NA	1300	0.07	0.53	0.32

TABLE A-8 (concluded)

CITY OF LONGVIEW MASTER DRAINAGE STUDY
 Eastman Lake Creek Watershed Time-of-Concentration
 Fully Developed Watershed Conditions

Sub- Area	Drainage Area	Sheet Flow				Shallow Concentrated Flow - Paved				Shallow Concentrated Flow - Unpaved				Pipe or Channel Flow			SCS Lag
		n	L	S	TT	L	S	V	TT	L	S	V	TT	L	TT	TC	
	(acres)	(Mann- ing's)	(ft)	(ft/ft)	(hrs)	(ft)	(ft/ft)	(fps)	(hrs)	(ft)	(ft/ft)	(fps)	(hrs)	(ft)	(hrs)	(hrs)	(hrs)
36	103	0.04	250	0.024	0.09	2900	0.021	3.0	0.27	NA	NA	NA	NA	1100	0.06	0.42	0.25
37	107	0.04	200	0.005	0.15	550	0.018	2.7	0.06	850	0.011	1.6	0.15	2100	0.12	0.48	0.29
38	105	0.04	250	0.040	0.08	1900	0.008	1.9	0.28	NA	NA	NA	NA	1900	0.11	0.47	0.28
39	265	0.04	300	0.050	0.08	1400	0.021	3.0	0.13	NA	NA	NA	NA	1700	0.09	0.30	0.18
40	1043	0.04	300	0.030	0.10	2600	0.017	2.6	0.28	NA	NA	NA	NA	11500	0.20	0.58	0.35
Total	6603																

Notes

- Sheet Flow Travel Time computed as follows:
 $TT = (0.007 * (nL)^{0.8}) / (P2^{0.5} * S^{0.4})$ where P2 = 2-Yr/24-Hr rainfall in inches = 4.5
- Shallow Concentrated Flow (Paved & Unpaved) Travel Time computed as follows:
 $TT = L / (3600 * V)$ where V = flow velocity in fps based on land slope and Figure 3.1, USDA, 1986
- Pipe or Channel Flow Travel Time computed as follows:
 $TT = L / (3600 * V)$ where V = 5 fps average flow velocity in pipes or channels
- Time-of-Concentration computed as follows:
 TC = summation of travel times computed in 1., 2., and 3. above

TABLE A-9
CITY OF LONGVIEW MASTER DRAINAGE STUDY
Iron Bridge Creek Watershed Curve Numbers and Percent Impervious (Existing Conditions)

Sub- Area	Total Area	Hydrologic Soil Group	Land Use	Area	% Total Area	Curve Number	Composite Curve Number (AMC II)	Composite Curve Number (AMC III)	Average Curve Number	Percent Impervious	Composite Percent Impervious
	(acres)			(acres)							
1	91	B	SFR	88	97	75	75.3	88.2	77.9	65	65.0
		C	SFR	3	3	83				65	
2	94	B	SFR	94	100	75	75.0	88.0	77.6	65	65.0
3	36	B	SFR	25	69	75	77.4	89.2	79.8	65	65.0
		C	SFR	11	31	83				65	
4	82	B	SFR	53	65	75	79.3	91.0	81.6	65	67.0
		C	SFR	5	6	83				65	
		B	I	24	29	88				72	
5	253	B	SFR	120	47	75	81.2	92.0	83.4	65	68.1
		C	SFR	52	21	83				65	
		B	C,PU	26	10	92				80	
		B	I	55	22	88				72	
6	260	B	SFR	129	50	75	81.2	92.0	83.4	65	69.9
		C	SFR	68	26	83				65	
		B	C,PU	63	24	92				80	
		C	C,PU	4	2	94				80	
7	163	B	SFR	114	70	75	77.4	89.2	79.8	65	65.0
		C	SFR	49	30	83				65	
8	116	B	SFR	25	22	75	86.9	92.6	88.0	65	73.1
		C	SFR	28	24	83				65	
		B	C,PU	21	18	92				80	
		C	C,PU	42	36	94				80	
9	67	B	SFR	49	73	75	79.7	91.0	81.9	65	69.0
		B	C,PU	15	22	92				80	
		C	C,PU	3	4	94				80	
10	103	B	C,PU	16	16	92	78.7	90.4	81.0	80	23.4
		C	C,PU	6	6	94				80	
		B	UNDEV	16	16	65				8	
		C	UNDEV	50	49	76				8	
		D	UNDEV	15	15	82				8	

TABLE A-9 (concluded)

CITY OF LONGVIEW MASTER DRAINAGE STUDY
 Iron Bridge Creek Watershed Curve Numbers and Percent Impervious (Existing Conditions)

Sub-Area	Total Area	Hydrologic Soil Group	Land Use	Area	% Total Area	Curve Number	Composite Curve Number (AMC II)	Composite Curve Number (AMC III)	Average Curve Number	Percent Impervious	Composite Percent Impervious
	(acres)			(acres)							
11	119	B	SFR	37	31	75	84.7	93.4	86.5	65	69.8
		B	I	51	43	88				72	
		C	I	31	26	91				72	
11A	90	B	SFR	23	26	75	86.8	94.4	88.3	65	71.9
		C	SFR	7	8	83				65	
		B	C,PU	4	4	92				80	
		C	C,PU	51	57	94				80	
		D	P	5	6	69				25	
12	354	B	C,PU	151	43	92	86.8	94.4	88.3	80	58.0
		C	C,PU	86	24	94				80	
		B	I	5	1	88				72	
		C	I	5	1	91				72	
		B	UNDEV	26	7	65				8	
		C	UNDEV	81	23	76				8	
13	57	B	I	15	26	88	74.7	88.0	77.4	72	33.8
		C	I	8	14	91				72	
		B	UNDEV	34	60	65				8	
14	487	A	UNDEV	21	4	43	76.3	89.0	78.9	5	5.0
		B	UNDEV	12	2	65				5	
		C	UNDEV	289	59	76				5	
		D	UNDEV	165	34	82				5	
TOTAL	2372										

Note: Average Curve Number = $CNII + 0.2(CNIII - CNII)$

TABLE A-10
CITY OF LONGVIEW MASTER DRAINAGE STUDY
Iron Bridge Creek Watershed Time-of-Concentration (Existing Conditions)

Sub- Area	Drainage Area	Sheet Flow				Shallow Concentrated Flow - Paved				Shallow Concentrated Flow - Unpaved				Pipe or Channel Flow			SCS Lag
		n	L	S	TT	L	S	V	TT	L	S	V	TT	L	TT	TC	
	(acres)	(Mann- ing's)	(ft)	(ft/ft)	(hrs)	(ft)	(ft/ft)	(fps)	(hrs)	(ft)	(ft/ft)	(fps)	(hrs)	(ft)	(hrs)	(hrs)	(hrs)
1	91	0.04	350	0.034	0.11	1050	0.027	3.2	0.09	700	0.010	1.5	0.13	2150	0.12	0.45	0.27
2	94	0.04	200	0.020	0.08	600	0.017	2.0	0.08	500	0.016	1.9	0.07	1400	0.08	0.32	0.19
3	36	0.04	250	0.020	0.10	2000	0.015	2.4	0.23	NA	NA	NA	NA	150	0.01	0.34	0.20
4	82	0.04	200	0.075	0.05	1000	0.021	2.9	0.10	650	0.031	2.7	0.07	1400	0.08	0.29	0.17
5	253	0.04	100	0.020	0.05	1000	0.028	3.4	0.08	300	0.023	2.3	0.04	3600	0.20	0.37	0.22
6	260	0.04	200	0.025	0.08	1300	0.027	3.3	0.11	NA	NA	NA	NA	3400	0.19	0.37	0.22
7	163	0.04	200	0.025	0.08	NA	NA	NA	NA	1900	0.011	1.6	0.33	2000	0.11	0.52	0.31
8	116	0.04	300	0.020	0.12	NA	NA	NA	NA	900	0.028	2.5	0.10	2850	0.16	0.37	0.22
9	67	0.04	300	0.025	0.11	650	0.015	2.5	0.07	400	0.005	1.1	0.10	2300	0.13	0.41	0.24
10	103	0.04	150	0.040	0.05	NA	NA	NA	NA	950	0.040	3.0	0.09	2700	0.15	0.29	0.17
11	119	0.04	250	0.008	0.14	NA	NA	NA	NA	500	0.010	1.5	0.09	2700	0.15	0.39	0.23
11A	90	0.04	300	0.010	0.15	NA	NA	NA	NA	800	0.015	1.9	0.12	1450	0.08	0.35	0.21
12	354	0.04	150	0.040	0.05	NA	NA	NA	NA	1050	0.010	1.5	0.19	6500	0.36	0.61	0.36
13	57	0.04	200	0.020	0.08	NA	NA	NA	NA	1000	0.005	1.1	0.25	2400	0.13	0.47	0.28
14	487	0.04	200	0.020	0.08	NA	NA	NA	NA	200	0.025	2.4	0.02	8200	0.46	0.56	0.34
Total	2372																

Notes

1. Sheet Flow Travel Time computed as follows:
 $TT = (0.007 * (nL)^{0.8}) / (P2^{0.5} * S^{0.4})$ where P2 = 2-Yr/24-Hr rainfall in inches = 4.5
2. Shallow Concentrated Flow (Paved & Unpaved) Travel Time computed as follows:
 $TT = L / (3600 * V)$ where V = flow velocity in fps based on land slope and Figure 3.1, USDA, 1986
3. Pipe or Channel Flow Travel Time computed as follows:
 $TT = L / (3600 * V)$ where V = 5 fps average flow velocity in pipes or channels
4. Time-of-Concentration computed as follows:
 $TC = \text{summation of travel times computed in 1., 2., and 3. above}$
5. SCS Lag = 0.6 TC

TABLE A-11
CITY OF LONGVIEW MASTER DRAINAGE STUDY
Iron Bridge Creek Watershed Curve Numbers and Percent Impervious
Fully Developed Watershed Conditions
September 8, 1990 File IBCCNFD.wk1 JNH

Sub-Area	Total Area	Hydrologic Soil Group	Land Use	Area	% Total Area	Curve Number	Composite Curve Number	Composite Curve Number	Average Curve Number	Percent Impervious	Composite Percent Impervious
	(acres)			(acres)			(ANC II)	(ANC III)			
1	91	B	SFR	88	97	79	79.2	91.0	81.6	65	65.0
		C	SFR	3	3	86				65	
2	94	B	SFR	94	100	79	79.0	91.0	81.4	65	65.0
3	36	B	SFR	25	69	79	81.1	92.0	83.3	65	65.0
		C	SFR	11	31	86				65	
4	82	B	SFR	53	65	79	82.1	92.1	84.1	65	67.0
		C	SFR	5	6	86				65	
		B	I	24	29	88				72	
5	253	B	SFR	120	47	79	83.7	93.0	85.6	65	68.1
		C	SFR	52	21	86				65	
		B	C,PU	26	10	92				80	
		B	I	55	22	88				72	
6	260	B	SFR	129	50	79	84.0	93.0	85.8	65	69.9
		C	SFR	68	26	86				65	
		B	C,PU	63	24	92				80	
		C	C,PU	4	2	94				80	
7	163	B	SFR	114	70	79	81.1	92.0	83.3	65	65.0
		C	SFR	49	30	86				65	
8	116	B	SFR	25	22	79	88.5	95.5	89.9	65	73.1
		C	SFR	28	24	86				65	
		B	C,PU	21	18	92				80	
		C	C,PU	42	36	94				80	
9	67	B	SFR	49	73	79	82.6	92.6	84.6	65	69.0
		B	C,PU	15	22	92				80	
		C	C,PU	3	4	94				80	
10	103	B	C,PU	16	16	92	86.7	94.7	88.3	80	23.4
		C	C,PU	6	6	94				80	
		B	UNDEV	16	16	79				8	
		C	UNDEV	50	49	86				.8	
		D	UNDEV	15	15	89				8	

TABLE A-11 (concluded)

CITY OF LONGVIEW MASTER DRAINAGE STUDY
 Iron Bridge Creek Watershed Curve Numbers and Percent Impervious
 Fully Developed Watershed Conditions
 September 8, 1990 File IBCCNFD.wk1 JNH

Sub-Area	Total Area	Hydrologic Soil Group	Land Use	% Total Area	% Total Area	Curve Number	Composite Curve Number (AMC II)	Composite Curve Number (AMC III)	Average Curve Number	Percent Impervious	Composite Percent Impervious
	(acres)										
11	119	B	SFR	37	31	79	86.0	94.0	87.6	65	69.8
		B	I	51	43	88				72	
		C	I	31	26	91				72	
11A	90	B	SFR	23	26	79	88.6	95.6	90.0	65	71.9
		C	SFR	7	8	86				65	
		B	C,PU	4	4	92				80	
		C	C,PU	51	57	94				80	
		B	P	5	6	79				25	
12	354	B	C,PU	151	43	92	90.1	96.1	91.3	80	58.0
		C	C,PU	86	24	94				80	
		B	I	5	1	88				72	
		C	I	5	1	91				72	
		B	UNDEV	26	7	79				8	
		C	UNDEV	81	23	86				8	
13	57	B	I	15	26	88	83.1	93.0	85.0	72	33.8
		C	I	8	14	91				72	
		B	UNDEV	34	60	79				8	
14	487	A	UNDEV	21	4	68	86.1	94.1	87.7	5	5.0
		B	UNDEV	12	2	79				5	
		C	UNDEV	289	59	86				5	
		D	UNDEV	165	34	89				5	
TOTAL	2372										

Note: Average Curve Number = $CN_{II} + 0.2(CN_{III} - CN_{II})$

Hydrologic Soil Group	Fully Developed Conditions Minimum SCS Curve Number (C = 0.70)
A	68
B	79
C	86
D	89

TABLE A-12
CITY OF LONGVIEW MASTER DRAINAGE STUDY
Iron Bridge Creek Watershed Time-of-Concentration (Fully Developed Conditions)

Sub- Area	Drainage Area	n	Sheet Flow				Shallow Concentrated Flow - Paved				Shallow Concentrated Flow - Unpaved				Pipe or Channel Flow			SCS Lag
			L	S	TT		L	S	V	TT	L	S	V	TT	L	TT	TC	
	(acres)	(Mann- ing's)	(ft)	(ft/ft)	(hrs)	(ft)	(ft/ft)	(fps)	(hrs)	(ft)	(ft/ft)	(fps)	(hrs)	(ft)	(hrs)	(hrs)	(hrs)	
1	91	0.04	350	0.034	0.11	1050	0.027	3.2	0.09	700	0.010	1.5	0.13	2150	0.12	0.45	0.27	
2	94	0.04	200	0.020	0.08	600	0.017	2.0	0.08	500	0.016	1.9	0.07	1400	0.08	0.32	0.19	
3	36	0.04	250	0.020	0.10	2000	0.015	2.4	0.23	NA	NA	NA	NA	150	0.01	0.34	0.20	
4	82	0.04	200	0.075	0.05	1000	0.021	2.9	0.10	650	0.031	2.7	0.07	1400	0.08	0.29	0.17	
5	253	0.04	100	0.020	0.05	1000	0.028	3.4	0.08	300	0.023	2.3	0.04	3600	0.20	0.37	0.22	
6	260	0.04	200	0.025	0.08	1300	0.027	3.3	0.11	NA	NA	NA	NA	3400	0.19	0.37	0.22	
7	163	0.04	200	0.025	0.08	NA	NA	NA	NA	1900	0.011	1.6	0.33	2000	0.11	0.52	0.31	
8	116	0.04	300	0.020	0.12	NA	NA	NA	NA	900	0.028	2.5	0.10	2850	0.16	0.37	0.22	
9	67	0.04	300	0.025	0.11	650	0.015	2.5	0.07	400	0.005	1.1	0.10	2300	0.13	0.41	0.24	
10	103	0.04	150	0.040	0.05	NA	NA	NA	NA	950	0.040	3.0	0.09	2700	0.15	0.29	0.17	
11	119	0.04	250	0.008	0.14	NA	NA	NA	NA	500	0.010	1.5	0.09	2700	0.15	0.39	0.23	
11A	90	0.04	300	0.010	0.15	NA	NA	NA	NA	800	0.015	1.9	0.12	1450	0.08	0.35	0.21	
12	354	0.04	150	0.040	0.05	NA	NA	NA	NA	1050	0.010	1.5	0.19	6500	0.36	0.61	0.36	
13	57	0.04	200	0.020	0.08	NA	NA	NA	NA	1000	0.005	1.1	0.25	2400	0.13	0.47	0.28	
14	487	0.04	200	0.020	0.08	NA	NA	NA	NA	200	0.025	2.4	0.02	8200	0.46	0.56	0.34	
total	2372	(Total)																

Notes

1. Sheet Flow Travel Time computed as follows:

$$TT = (0.007 * (nL)^{0.8}) / (P2^{0.5} * S^{0.4}) \quad \text{where } P2 = 2\text{-Yr}/24\text{-Hr rainfall in inches} = 4.5$$

2. Shallow Concentrated Flow (Paved & Unpaved) Travel Time computed as follows:

$$TT = L / (3600 * V) \quad \text{where } V = \text{flow velocity in fps based on land slope and Figure 3.1, USDA, 1986}$$

3. Pipe or Channel Flow Travel Time computed as follows:

$$TT = L / (3600 * V) \quad \text{where } V = 5 \text{ fps average flow velocity in pipes or channels}$$

4. Time-of-Concentration computed as follows:

$$TC = \text{summation of travel times computed in 1., 2., and 3. above}$$

5. SCS Lag = 0.6 TC

APPENDIX B

Channel Design Feature Tables

Note: Design discharges reflect ultimate watershed development conditions and master drainage plan channel improvements. Ultimate watershed development conditions were assumed to reflect a minimum density equivalent to SF-4 zoning (5 units per acre) in all areas having less dense conditions.

APPENDIX B
LIST OF TABLES

<u>Table</u>		<u>Page</u>
B-1	Coushatta Hills Creek	B-1
B-2	Drain No. 2/Oak Branch/Murray Creek	B-2
B-3	Eastman Lake Creek/Drain No. 1	B-6
B-4	Elm Branch	B-8
B-5	Gilmer Creek	B-9
B-6	Grace Creek	B-10
B-7	Guthrie Creek	B-16
B-8	Harris Creek/Drain No. 4	B-18
B-9	Hawkins Creek/LaFamo Creek	B-22
B-10	Iron Bridge Creek	B-28
B-11	Johnson Creek	B-29
B-12	McCann Creek	B-31
B-13	Oakland Creek	B-33
B-14	Peterson Court Creek	B-35
B-15	Ray Creek	B-36
B-16	School Branch/Drain No. 3	B-38
B-17	Wade Creek	B-40

TABLE B-1
CHANNEL DESIGN FEATURES - COUSHATTA HILLS

Watershed Identification	Reach Location		Design Features					Number of Drops	Length (ft)	Top Width (ft)	Required Easement (ft)
	General Description	G.I.S. Nos.	Type	Discharge (cfs)	Slope (ft/ft)	Bottom Width (ft)	Depth (ft)				
Coushatta Hills Creek											
CH-1	Conf. w/Oakland to downstream face of Sequoyah	1.01-1.10	C	2,250	0.003	15	7.1	3	1,930	29	40
	Downstream face of Sequoyah to 65 ft upstream of Sequoyah	1.11B (50%)	C	1,500	0.003	15	5.7	1	315	26	35
	65 ft upstream of Sequoyah to downstream face of Navaho Trail	1.11B (50%)-1.13	C	1,500	0.004	10	6.3	1	900	23	35
	Downstream face of Navaho Trail to 575 ft upstream of Hwy 259	1.14-1.19 (50%)	C	890	0.0055	10	4.3	4	2,176	19	30

Type:
 G - Grass
 C - Concrete
 G/C - Grass/Concrete
 N/I - No Improvement

B-1

TABLE B-2

CHANNEL DESIGN FEATURES - DRAIN NO. 2/OAK BRANCH/MURRAY CREEK

Watershed Identification	Reach Location		Design Features					Number of Drops	Length (ft)	Top Width (ft)	Required Easement (ft)
	General Description	G.I.S. Nos.	Type	Discharge (cfs)	Slope (ft/ft)	Bottom Width (ft)	Depth (ft)				
Drain No. 2											
DR2-1A	Confluence with Grace to tributary entering below McCann Road (no improvements)	1.01-1.05 (70%)	NI	--	--	--	--	--	--	--	--
DR2-1A/ DR2-1B	500 ft below McCann Road to 100 ft Upstream of McCann Road	1.05 (30%) 1.06 A, B & C 1.07 (20%)	G/C	7,390	0.0027	85	6.5	0	560	111	130
DR2-1B	100 ft Upstream of McCann to Upstream face of Hawkins	1.07 (80%) 1.08	G/C	7,390	0.0014	65	9.2	0	600	102	120
	Upstream face of Hawkins to 160 ft Upstream of Hawkins	1.09	G/C	7,390	0.0021	60	8.6	0	160	94	115
	160 ft Upstream of Hawkins to Confluence with Murray	1.10-1.12	G/C	6,920	0.002	60	8.4	1	1,730	94	115
Oak Branch											
OB-1	Confluence with Murray Creek to 760 ft Downstream of Hill St.	1.01 (45%)	G	2,870	0.0044	45	6.4	0	910	83	105
	760 ft Downstream of Hill St. to 100 ft Downstream of Hill St.	1.01 (45%)	G	2,870	0.005	45	6.2	0	660	82	100
	100 ft Downstream of Hill St. to 100 ft Upstream of Hill St.	1.01 (10%) 1.02A & B 1.03A (10%)	G/C	2,730	0.0029	45	5.2	0	240	66	85
	100 ft Upstream of Hill St. to 770 ft Upstream of Hill St.	1.03A (90%)	G/C	2,730	0.0014	50	6.1	0	670	74	95

B-2

TABLE B-2 (Cont'd)

CHANNEL DESIGN FEATURES - DRAIN NO. 2/OAK BRANCH/MURRAY CREEK

Watershed Identification	Reach Location		Design Features					Number of Drops	Length (ft)	Top Width (ft)	Required Easement (ft)
	General Description	G.I.S. Nos.	Type	Discharge (cfs)	Slope (ft/ft)	Bottom Width (ft)	Depth (ft)				
OB-1 (Cont'd)	770 ft Upstream of Hill St. to 1,720 ft Upstream of Hill St. (Trib)	1.03B (50%)	G/C	2,640	0.0014	50	6.0	0	950	74	95
	1,720 ft Upstream of Hill St. (Trib) to 2,645 ft Upstream of Hill St. (Trib)	1.03B (50%)	G	2,420	0.0038	45	6.1	1	925	82	100
	2,645 ft Upstream of Hill St. (Trib) to 1,230 ft Downstream of Airline	1.04-1.05	G	2,095	0.0081	30	5.5	0	790	63	85
	1,230 ft Downstream of Airline to 570 ft Downstream of Airline	1.06 (45%)	G	1,780	0.0081	30	5.0	0	660	60	80
	570 ft Downstream of Airline to 50 ft Downstream of Airline	1.06 (50%)	G	1,780	0.0067	30	5.3	0	520	62	80
	50 ft Downstream of Airline to 155 ft Upstream of Airline	1.06 (5%) 1.09 (10%)	G	1,780	0.0074	30	5.1	0	310	61	80
	155 ft Upstream of Airline Rd. to 1,935 ft Upstream of Airline	1.09 (90%) 1.10 1.11 (50%)	G	1,730	0.0072	30	5.1	0	1,780	61	80
	1,935 ft Upstream of Airline (Trib) to 1,370 ft Downstream of Henderson Hwy 259	N/A	G	1,520	0.0047	30	5.3	0	600	62	80
	1,370 ft Downstream of Hwy 259 to 420 ft Downstream of Hwy 259	N/A	G	1,120	0.0047	15	5.8	0	950	50	60
420 ft Downstream of Hwy 259 Upstream face of Hwy 259	N/A	G	705	0.0081	5	5.2	1	670	36	45	

B-3

TABLE B-2 (Cont'd)

CHANNEL DESIGN FEATURES - DRAIN NO. 2/OAK BRANCH/MURRAY CREEK

Watershed Identification	Reach Location		Design Features					Number of Drops	Length (ft)	Top Width (ft)	Required Easement (ft)
	General Description	G.I.S. Nos.	Type	Discharge (cfs)	Slope (ft/ft)	Bottom Width (ft)	Depth (ft)				
OB-1 (Cont'd)	Upstream face of Hwy 259 to 260 ft Upstream Hwy 259	N/A	G	705	0.0062	5	5.5	1	260	38	50
Murray Creek											
MU-1	Confluence with Oak Branch to 100 ft below Airline Dr.	1.01 (90%)	G	4,140	0.0018	6	8.7	0	1,250	112	130
	100 ft below Airline Dr. to Airline Dr.	1.01 (10%)	G	3,650	0.002	50	8.6	0	100	102	120
	Airline Dr. to 900 ft above Airline Dr.	1.02 1.03 (90%)	G	3,650	0.003	50	7.7	0	935	96	115
	To 1,500 ft above Airline Dr.	1.03 (10%)- 1.04 (60%)	G/C	3,060	0.004	55	4.5	1	600	73	95
MU-2	To 3,100 ft above Airline Dr.	1.04 (40%)- 1.06 (50%)	G	2,030	0.0054	30	6.0	0	1,600	66	85
	To 5,130 ft above Airline Dr.	1.06 (50%) 1.08	G	1,550	0.0092	30	4.5	0	1,530	57	75
	2,220 ft below Hwy 259 to 570 ft below Hwy 259	1.09 (72%)	G	1,220	0.0077	25	4.5	0	1,650	52	70
	570 ft to 500 ft below Hwy 259	1.09 (3%)	G	1,040	0.0043	20	5.2	1	70	51	60
	500 ft Downstream to Hwy 259	1.09 (25%)	G	1,040	0.0038	20	5.4	0	500	52	60

B-4

TABLE B-2 (Concluded)

CHANNEL DESIGN FEATURES - DRAIN NO. 2/OAK BRANCH/MURRAY CREEK

Watershed Identification	Reach Location		Design Features					Number of Drops	Length (ft)	Top Width (ft)	Required Easement (ft)
	General Description	G.I.S. Nos.	Type	Discharge (cfs)	Slope (ft/ft)	Bottom Width (ft)	Depth (ft)				
MU-2 (Cont'd)	Downstream end of Hwy 259 to 93 ft above	1.10 1.11 (5%)	G	860	0.0059	15	4.8	0	320	44	55
	93 ft to 993 ft above Hwy 259	1.11 (50%)	G	860	0.0067	15	8.7	0	900	67	75
MU(T)-1	Mouth to 700 ft above Murray Creek	3.01 (50%)	G/C	1,030	0.005	25	3.7	0	1,190	40	60
	700 ft to 1,700 ft above Murray Creek	3.01 (50%) 3.02 3.03 (10%)	G	1,030	0.01	20	4.2	0	1,850	45	55
	1,000 ft to 1,500 ft below Hwy 259	3.03 (40%)	G	470	0.01	10	3.6	0	800	32	40
MU(T)-1A	Mouth to 860 ft above Murray Creek	N/A (stream not shown on GRID map)	G	760	0.006	20	4.1	1	860	44	55

B-5

Type:
 G - Grass
 C - Concrete
 G/C - Grass/Concrete
 N/I - No Improvement

TABLE B-3

CHANNEL DESIGN FEATURES - EASTMAN LAKE CREEK/DRAIN NO. 1

Watershed Identification	Reach Location		Design Features					Number of Drops	Length (ft)	Top Width (ft)	Required Easement (ft)
	General Description	G.I.S. Nos.	Type	Discharge (cfs)	Slope (ft/ft)	Bottom Width (ft)	Depth (ft)				
Eastman Lake Creek											
EA-1 to EA-7	Eastman Lake Creek IH 20 to confluence Drain No. 1	1.01-1.28	G	--	--	80	--	0	20,600	--	--
EA(T)-1	Mouth to US 259	6.01-6.02A/B	G	1,020	0.010	10	6	0	1,800	45	55
	US 259 to Lilly St.	6.03-6.04A/B	G	500	0.010	5	5	0	550	35	45
EA(T)-2	Mouth to SFRR	7.01-7.02	G	2,300	0.009	60	5	0	3,200	90	110
	SFRR to tributary	7.03	G	1,740	0.009	20	5.5	0	1,500	55	65
EA(T)-3	Tributary to Gum Springs Road	No G.I.S. Nos. assigned	G	610	0.009	10	5.5	0	1,900	45	55
	Mouth to US 259	8.01-8.03A/B	G	1,000	0.009	10	6	0	3,200	45	55
EA(T)-4	US 259 to Birdsong St.	8.04-8.07A/B	G	560	0.009	5	5.5	0	700	40	50
	Mouth of Lilly Creek to tributary	10.01-10.02	G	2,800	0.005	50	7	0	2,300	90	110
EA(T)-4	Tributary to US 259	10.03-10.04	G	2,050	0.005	35	7	0	900	75	95
	US 259 to El Paso St.	10.05-10.13	C	2,050	0.0035	20	6.5	0	2,500	60	70
EA(T)-5	El Paso St. to upper end	10.14-10.19	C	1,470	0.0035	10	6	0	2,000	20	30
	Mouth to upper end	15.01	G	8,100	0.011	10	6	0	900	45	55
EA(T)-6	Mouth to US 259	19.01-19.03	G	1,500	0.0075	15	6	0	2,400	50	60
	US 259 to Texas and Pacific Railroad	19.04-19.05	C	1,290	0.0125	10	6	0	650	20	30
EA(T)-7	Mouth to 1,500 LF upstream	22.01-22.03	G	1,400	0.009	20	6	1	1,500	55	65
	1,500 LF above mouth to upper end	22.04	G	1,040	0.009	10	6	1	1,500	45	55

TABLE B-3 (Concluded)

Watershed Identification	Reach Location		Design Features			Bottom Width (ft)	Depth (ft)	Number of Drops	Length (ft)	Top Width (ft)	Required Easement (ft)
	General Description	G.I.S. Nos.	Type	Discharge (cfs)	Slope (ft/ft)						
EA-8	Confluence with Drain No. 1 to above Doyle St.	1.29-1.39A/B	G	1,720	0.0068	20	6	0	6,100	55	65
Drain No. 1											
DR1-1*	Confluence to U.S. 80	1.01-1.03	G	--	--	80	--	--	1,200	--	--
DR1-1	U.S. 80 to 3,500 LF north	1.04-1.07	G	6,220	0.0044	80	6	0	3,500	115	135
DR1(T)-1	Mouth of east tributary to 1400 LF north	4.01 (50%)	G	1,790	0.007	20	7	0	1,400	60	70
	1400 LF above mouth to upper end	4.01 (50%)-4.03 (70%)	G	770	0.007	10	6	0	2,100	45	55
DR1-2	Confluence with east tributary to confluence with west tributary	1.08	G	4,410	0.0044	80	6	0	1,900	115	135
DR1(T)-2	Mouth of west tributary to Alpine St.	5.01-5.02	G	950	0.005	10	7	0	2,300	50	60
DR1-3	West tributary confluence to to 3700 LF north	1.09-1.16	G	3,770	0.044	80	6	0	3,700	115	135
DR1(T)-3	Tributary mouth to upper end	10.01-10.04	G	1,030	0.007	10	6	0	1,900	45	55
DR1-4	Above DR1(T)-3 tributary to below Loop 281	1.17	G	2,450	0.0044	50	6	0	1,600	85	105
	Below Loop 281 to above Loop 281	1.18-1.24	G	1,880	0.0044	20	6	0	2,800	55	65

Type: G - Grass
 C - Concrete
 G/C - Grass/Concrete
 N/I - No Improvement

* Included with EA-1 to EA-7 for cost estimates in Table C-3.

TABLE B-4
CHANNEL DESIGN FEATURES - ELM BRANCH

Watershed Identification	Reach Location		Design Features					Number of Drops	Length (ft)	Top Width (ft)	Required Easement (ft)
	General Description	G.I.S. Nos.	Type	Discharge (cfs)	Slope (ft/ft)	Bottom Width (ft)	Depth (ft)				
Elm Branch											
EL-1	Confluence with Ray Creek to Miles Street	1.01-1.02	G	2,449	0.0048	30	7.0	0	1,300	72	90
	Miles Street to Judson Road	1.03-1.10A	C	2,449	0.0035	15	7.0	1	1,860	29	40
	Judson Road to 950 ft above Pfliler Precise	1.10B-1.17	G	2,000	0.007	15	7.0	1	2,320	57	65
	950 ft above Pfliler Precise to 1,750 ft above Pfliler Precise	1.18-1.21 (10%)	G	865	0.0093	10	5.0	0	800	40	50
EL(T)-1	Elm Creek to 800 ft above Elm Creek	6.01-6.02 (20%)	G	690	0.15	15	3.4	0	800	35	45

Type:
 G - Grass
 C - Concrete
 G/C - Grass/Concrete
 N/I - No Improvement

B-8

TABLE B-5
CHANNEL DESIGN FEATURES - GILMER CREEK

Watershed Identification	Reach Location		Design Features					Number of Drops	Length (ft)	Top Width (ft)	Required Easement (ft)	
	General Description	G.I.S. Nos.	Type	Discharge (cfs)	Slope (ft/ft)	Bottom Width (ft)	Depth (ft)					
Gilmer Creek												
GI-1	Confluence with Grace Creek to Bill Owens Parkway	1.01	G	3,055	0.0052	60	5.5	0	395	93	115	
	Bill Owens Parkway to 2,100 ft upstream	1.02-1.07	G/C	3,055	0.006	40	4.5	0	2,640	58	80	
GI-2	2,100 ft upstream of Bill Owens to 665 ft below H.G. Mosley	1.08-1.09 (50%)	G/C	2,434	0.006	40	4.0	0	725	51	70	
	665 ft below H.G. Mosely to H.G. Mosely	1.09 (50%)-1.10	N/I	2,434	--	--	--	--	665			
	2,000 ft above H.G. Mosely (lake)	1.11-1.18	N/I	2,462	--	--	--	--	2,000			
GI-3	Upstream extent of lake to Loop 281	1.19-1.28	G	2,000	0.004	40	5.7	0	1,605	74	95	
	Loop 281 to 1,200 ft upstream	1.29-1.32	G	1,641	0.007	10	5.8	2	1,200	45	55	
	GI(T)-1	Gilmer Cr to 240 ft above Gilmer Cr	6.01 (50%)	G	1,580	0.004	30	5.6	0	240	64	85
		240 ft above Gilmer Creek to 85 ft below Gilmer Rd	6.01 (40%)	G	1,580	0.008	30	4.7	0	575	58	80
		85 ft below Gilmer Rd to 900 ft below H.G. Mosley	6.01 (10%)-6.05 (30%)	G	1,460	0.007	30	4.7	0	1,385	58	80
900 ft below H.G. Mosley to 200 ft above H.G. Mosley		6.05 (70%)-6.09 (30%)	G	1,460	0.008	30	4.5	3	1,000	57	75	
	200 ft above H.G. Mosley to 300 ft above Pineridge St	6.09 (70%)-6.21 (5%)	G/C	1,020	0.004	5	5.9	5	2,660	29	40	

Type: G - Grass
C - Concrete
G/C - Grass/Concrete
N/I - No Improvement

TABLE B-6

CHANNEL DESIGN FEATURES - GRACE CREEK

Watershed Identification	Reach Location		Design Features					Number of Drops	Length (ft)	Top Width (ft)	Required Easement (ft)
	General Description	G.I.S. Nos.	Type	Discharge (cfs)	Slope (ft/ft)	Bottom Width (ft)	Depth (ft)				
Grace Creek											
GR-1,2,3	FM 1845 to Missouri Pacific RR	1.01-1.11	G/C	40,870	0.00098	75	12.0	0	7,035	123	145
GR-4	Missouri Pacific RR to Hwy 31	1.12-1.18	G/C	40,020	0.00098	75	12.0	0	4,500	123	145
	Hwy 31 to Texas and Pacific RR	1.19-1.24	G/C	39,800	0.00098	75	15.0	1	2,310	135	155
	Texas and Pacific RR to Hwy 80	1.24-1.30	G/C	34,340	0.00098	75	10.0	0	900	115	135
GR-5	Hwy 80 to 2,750 ft upstream of Hwy 80	1.31-1.34	G/C	29,740	0.00106	65	8.0	0	2,750	97	115
	2,750 ft upstream of Hwy 80 to 4,275 ft upstream of Hwy 80	1.35-1.40	G/C	29,690	0.00123	65	8.0	0	1,550	97	115
GR-6	4,275 ft upstream of Hwy 80 to 1,150 ft downstream of Fairmont	1.41-1.42	G/C	29,620	0.00123	65	8.0	0	1,125	97	115
	1,150 ft downstream of Fairmont 990 ft to upstream of Fairmont	1.43-1.51	G/C	28,050	0.00123	65	10.0	0	1,650	105	125
GR-7	990 ft upstream of Fairmont to 2,190 ft upstream of Fairmont	1.52-1.53	G/C	27,970	0.00123	60	10.0	0	1,910	100	120
	2,190 ft upstream of Fairmont to 700 ft downstream of H.G. Mosely	1.54-1.56	G/C	27,880	0.00254	60	12.0	0	1,475	107	125
GR-8	700 ft downstream of H.G. Mosely to 3,050 ft upstream of H.G. Mosely	1.57-1.68	G/C	27,780	0.00254	55	10.0	0	2,425	95	115

B-10

TABLE B-6 (Cont'd)

CHANNEL DESIGN FEATURES - GRACE CREEK

Watershed Identification	Reach Location		Design Features					Number of Drops	Length (ft)	Top Width (ft)	Required Easement (ft)
	General Description	G.I.S. Nos.	Type	Discharge (cfs)	Slope (ft/ft)	Bottom Width (ft)	Depth (ft)				
GR-8, 9	3,050 ft upstream of H.G. Mosely to 600 ft downstream of Hwy 281	1.69-1.70	G/C	27,560	0.00254	55	8.0	0	2,560	87	110
GR-10	600 ft downstream of Hwy 281 to Hwy 281	1.71-1.73	G/C	27,230	0.00254	55	8.0	0	600	87	110
GR-11, 12A, 12B	Hwy 281 to 2,500 ft upstream of Hwy 281 (no improvements)	1.74-1.76 (20%)	N/I						2,500		
GR-12B	2,500 ft upstream of Hwy 281 to 400 ft downstream of Spring Hill	1.76 (80%)-1.78	G	10,370	0.0023	100	5.0	0	3,800	130	150
	400 ft downstream of Spring Hill to 2,775 upstream of Spring Hill	1.79-1.85	G	10,130	0.0035	100	6.0	0	3,175	136	155
	2,775 upstream of Spring to 6,650 upstream of Spring Hill	1.86-1.89	G	10,130	0.0035	100	7.0	0	3,875	142	160
	6,650 upstream of Spring Hill to 9,700 upstream of Spring Hill	1.90-1.91	G	9,060	0.0025	100	5.0	0	3,050	130	150
GR-13	9,700 upstream of Spring Hill to 1,720 downstream of Greystone	1.92-1.93	G	5,440	0.0025	60	5.0	0	2,500	90	110
GR-14	1,720 downstream of Greystone to 1,650 upstream of Greystone	1.94-1.99A	G	4,070	0.0051	50	7.0	0	3,370	92	110
GR-15	1,650 upstream of Greystone to 3,300 upstream of Greystone	1.99B-1.99C	G	3,000	0.0051	40	6.0	0	1,650	76	95

B-11

TABLE B-6 (Cont'd)

CHANNEL DESIGN FEATURES - GRACE CREEK

Watershed Identification	Reach Location		Design Features					Number of Drops	Length (ft)	Top Width (ft)	Required Easement (ft)
	General Description	G.I.S. Nos.	Type	Discharge (cfs)	Slope (ft/ft)	Bottom Width (ft)	Depth (ft)				
GR-16	Winding Way to 2,100 ft upstream of Winding Way	1.99D-1.99F	G	2,020	0.0051	30	6.0	0	2,050	66	85
	2,100 ft upstream of Winding Way to 5,700 ft upstream of Winding Way	1.99G-1.99H	G	1,720	0.0066	20	6.0	0	3,700	56	65
GR(T)-1	Grace Creek to 520 ft upstream of Grace Creek	5.01 (90%)	G	1,310	0.011	50	3.0	1	520	68	90
	520 ft upstream of Grace Creek to 600 ft upstream of West Birdsong Street	5.01 (10%)-5.04 (50%)	G	1,310	0.009	50	3.2	0	940	69	90
	600 ft upstream of W. Birdsong Street to International and Great Northern RR	5.04 (50%)-5.05	G	1,310	0.008	45	3.5	0	640	66	85
	International and Great Northern RR to 500 ft upstream	5.06-5.07 (10%)	G	640	0.008	15	3.8	0	600	38	50
	1,000 ft downstream of South High Street to 600 ft downstream of South High Street	5.07 (90%)-5.08	G	640	0.01	15	3.6	0	520	37	45
	600 ft downstream of South High Street to 250 ft downstream of South High Street	5.09	G	640	0.015	15	3.3	1	280	45	35
GR(T)-2	Grace Creek to 2,100 ft upstream of Grace Creek	6.01-6.03 (90%)	G	1,260	0.004	30	5.01	0	2,400	60	80
	760 ft downstream of Ray Street to Ray Street	6.03 (10%)-6.05	G	1,260	0.007	30	4.3	0	760	56	75

B-12

TABLE B-6 (Cont'd)

CHANNEL DESIGN FEATURES - GRACE CREEK

Watershed Identification	Reach Location		Design Features					Number of Drops	Length (ft)	Top Width (ft)	Required Easement (ft)
	General Description	G.I.S. Nos.	Type	Discharge (cfs)	Slope (ft/ft)	Bottom Width (ft)	Depth (ft)				
GR(T)-2 (Cont'd)	Ray Street to 850 ft downstream of MoPac RR	6.06-6.07 (30%)	G	1,260	0.008	30	4.2	0	1,440	55	75
	850 ft downstream of MoPac RR to 250 ft upstream of MoPac RR	6.07 (70%)-6.09 (40%)	G	1,260	0.009	30	4	0	1,170	54	75
GR(T)-2A	Grace Creek to 500 ft upstream of Grace Creek	14.01	G	610	0.015	10	3.7	0	500	32	40
	500 ft upstream of Grace Creek to 200 ft above Hwy 63	14.02-14.04	G	610	0.015	10	3.7	1	410	32	40
	200 ft upstream of Hwy 63 to 490 ft upstream of Hwy 63	14.05	G	410	0.019	5	3.4	1	290	25	35
	490 ft upstream of Hwy 63 to Texas and Pacific RR bridge	NA	G	410	0.01	5	3.9	0	1,000	29	40
GR(T)-3	Grace Creek to 500 ft upstream of Bill Owens Parkway	30.01-30.03 (20%)	G	700	0.008	15	4	0	760	39	50
	500 ft upstream of Bill Owens Parkway to 1,240 ft upstream of Bill Owens Parkway	30.03 (30%)	G	700	0.013	15	3.6	0	940	37	45
GR(T)-4	Grace Creek to 70 ft upstream of Grace Creek	43.01 (5%)	G	910	0.013	30	3.1	0	70	49	70
	70 ft upstream of Grace Creek to 400 ft upstream of Grace Creek	43.01 (35%)	G	910	0.015	30	2.9	0	330	47	65

B-13

TABLE B-6 (Cont'd)
CHANNEL DESIGN FEATURES - GRACE CREEK

Watershed Identification	Reach Location		Design Features					Number of Drops	Length (ft)	Top Width (ft)	Required Easement (ft)
	General Description	G.I.S. Nos.	Type	Discharge (cfs)	Slope (ft/ft)	Bottom Width (ft)	Depth (ft)				
GR(T)-4 (Cont'd)	400 ft upstream of Grace Creek to 1,020 ft above Grace Creek	43.01 (55%)	G	910	0.013	20	3.7	1	285	42	50
GR(T)-5	Grace Creek to 230 ft upstream of Grace Creek	54.01 (40%)	G	1,050	0.012	25	3.5	1	230	46	65
	230 ft upstream of Grace Creek to 1400 ft downstream Loop 281	54.01 (60%) 54.05 (20%)	G	1,050	0.011	20	4	0	1,500	44	55
	1,400 ft to 500 ft downstream of Loop 281	54.05 (80%) 54.07 (60%)	G	1,050	0.011	15	4.6	1	1,170	42	50
	500 ft downstream of Loop 281 to Loop 281	54.07 (40%) 54.10	G	520	0.011	15	4.5	0	540	42	50
GR(T)-6	0 to 300 ft upstream of Grace Creek	1.01- 2.01 (5%)	G/C	1,630	0.004	45	3.6	0	300	54	75
	300 ft to 780 ft upstream of Grace Creek	2.01 (45%)	G	1,630	0.01	40	3.9	0	480	63	85
	780 ft to 2,220 ft upstream of Grace Creek	2.01 (50%) 2.02 (60%)	G	1,630	0.009	25	5	0	1,440	55	75
	2,220 ft downstream of McCann Road to 150 ft upstream of McCann Road	2.02 (40%) 2.20 (5%)	G	950	0.011	25	3.6	1	580	47	65
	150 ft upstream of McCann Road to 800 ft upstream of McCann Road	2.05 (40%)	G	950	0.01	25	3.7	0	660	47	65

B-14

TABLE B-6 (Concluded)

CHANNEL DESIGN FEATURES - GRACE CREEK

Watershed Identification	Reach Location		Design Features					Number of Drops	Length (ft)	Top Width (ft)	Required Easement (ft)
	General Description	G.I.S. Nos.	Type	Discharge (cfs)	Slope (ft/ft)	Bottom Width (ft)	Depth (ft)				
GR(T)-7	Grace Creek to 920 ft upstream of Grace Creek	72.01 (40%)	G	580	0.003	15	4.7	0	920	43	55
	920 ft to 1,500 ft upstream of Grace Creek	72.01 (20%)	G	580	0.009	15	3.6	0	580	36	45
	1,500 ft to 1,740 ft upstream of Grace Creek	72.01 (5%)	G	580	0.015	5	4.2	1	240	30	40
	1,740 ft to 2,240 ft upstream of Grace Creek	72.01 (25%)	G	580	0.01	5	4.5	0	500	32	40
	2,240 ft to 2,530 ft upstream of Grace Creek	72.01 (10%) 72.02 (30%)	G	580	0.011	5	4.7	0	290	32	40
GR(T)-8	Grace Creek to 830 ft upstream of Grace Creek	76.01- 76.02 (60%)	G	980	0.003	10	5.3	0	830	42	50
	830 ft to 2,950 ft upstream of Grace Creek	76.02 (40%)- 76.04 (70%)	G	980	0.006	10	5.7	0	2,120	44	55
	2,950 ft to 3,220 ft upstream of Grace Creek	76.04 (30%)	G	980	0.01	10	5.0	1	270	40	50
GR(T)-9	Grace Creek to 300 ft upstream of Grace Creek	77.01	G	720	0.01	30	2.9	0	300	47	65
	300 ft upstream of Grace Creek to 1,200 ft downstream of State Hwy 300	77.01 (50%)- 77.02 (40%)	G	720	0.008	15	4.2	10	660	40	50

Type: G - Grass
C - Concrete
G/C - Grass/Concrete
N/I - No Improvement

NOTE: GR-1, GR-2, etc. indicates primary design reaches used to group individual design reaches. These principal design reaches used in the prioritization of improvements process.

TABLE B-7
CHANNEL DESIGN FEATURES - GUTHRIE CREEK

Watershed Identification	Reach Location		Design Features					Number of Drops	Length (ft)	Top Width (ft)	Required Easement (ft)
	General Description	G.I.S. Nos.	Type	Discharge (cfs)	Slope (ft/ft)	Bottom Width (ft)	Depth (ft)				
Guthrie Creek											
GU-1	Confluence w/Grace Creek to McCann Road	1.01-1.09		(no improvements)							
	Downstream face of McCann Road to downstream face of Glencrest	1.10-1.12	G/C	13,540	0.002	70	11.2	1	1,410	115	130
GU-2	Downstream face of Glencrest to 100 ft upstream of Meadowbrook	1.13-1.19	G/C	12,790	0.002	70	10.0	1	1,220	110	130
	100 ft upstream of Meadowbrook to upstream face of Judson	1.20-1.26	G/C	12,190	0.0023	70	10.2	0	2,480	111	130
GU-3/ GU-4	Upstream face of Judson to 675 ft upstream of Judson	1.27-1.29 (20%)	G/C	11,730	0.002	65	10.7	1	675	108	130
GU-4	675 ft upstream of Judson to 1,265 ft upstream of Judson	1.29 (80%)- 1.30 (15%)	G/C	9,280	0.0024	60	9.4	0	590	98	120
GU-5	1,265 ft upstream of Judson to 1,575 ft upstream of Judson	1.30 (85%)- 1.31 (5%)	G	3,030	0.0024	40	8.1	0	310	89	110
	1,575 ft upstream of Judson to downstream face of 4th St	1.31 (95%)	G	3,030	0.005	15	9.0	2	1,325	69	80
GU-5/ GU-6	Downstream face of 4th St. to 750 ft above Wood Place	1.32- 1.38 (70%)	C	850	0.003	15	4.0	1	1,810	10	20
GU-6	750 ft above Wood Place to 100 ft above Pegues Place	1.38 (30%)-1.43B	G/C	850	0.004	15	4.6	3	760	33	45

B-16

TABLE B-7 (Concluded)

CHANNEL DESIGN FEATURES - GUTHRIE CREEK

Watershed Identification	Reach Location		Design Features					Number of Drops	Length (ft)	Top Width (ft)	Required Easement (ft)
	General Description	G.I.S. Nos.	Type	Discharge (cfs)	Slope (ft/ft)	Bottom Width (ft)	Depth (ft)				
GU-6 (Cont'd)	100 ft above Pegues Place to 150 ft below Ruth Dr	1.44-1.48	G/C	430	0.005	15	3.1	1	1,280	27	35
GU(T)-1	Glencrest Drive to Tupelo Drive	15.01	G/C	690	0.004	10	4.2	1	240	27	35
	Tupelo Drive to 600 ft above Tupelo Drive	15.03A&B	G/C	690	0.004	10	4.2	2	600	27	35
	600 ft above Tupelo Drive to High Street	15.04-15.06	G/C	690	0.004	10	4.2	2	960	27	35
	High Street to N. Center Street	15.07-15.46	G	350	0.009	5	3.7	0	1,325	27	35
	North Center Street to Henderson Street	15.49A&B 15.58 (50%)	G	350	0.016	5	3.3	1	695	25	35
GU(T)-2	Wood Place to Guthrie Creek	28.01	G	630	0.015	10	4	2	790	34	45
GU(T)-3	Guthrie Cr to 100 ft above LeDuke Blvd	34.01-34.05 (10%)	G	430	0.018	15	2.5	0	1,160	30	40
	100 ft above LeDuke Blvd. to 200 ft above Tenth Street	34.05 (90%)- 34.08 (25%)	G	430	0.009	10	3.5	0	750	31	40
	200 ft above Tenth St to 700 ft above Tenth St	34.08 (75%)	G	430	0.011	10	3.3	0	475	30	40

Type: G - Grass
 C - Concrete
 G/C - Grass/Concrete
 N/I - No Improvement

B-17

TABLE B-8

CHANNEL DESIGN FEATURES - HARRIS CREEK/DRAIN NO. 4

Watershed Identification	Reach Location		Design Features					Number of Drops	Length (ft)	Top Width (ft)	Easement (ft)
	General Description	G.I.S. Nos.	Type	Discharge (cfs)	Slope (ft/ft)	Bottom Width (ft)	Depth (ft)				
Harris Creek											
HA-1	Confluence with Grace to downstream face of Lake Lamond Road. Lake Lamond to remain in place	1.01-1.06	G/C	11,290	0.002	75	7.5	4	3,290	105	125
	Upstream end of Lake Lamond to 100 ft upstream of HG Mosley	1.15 (30%)	G/C	11,140	0.001	75	7.5	0	2,730	116	135
	100 ft Upstream of HG Mosley to 100 ft downstream of Hwy 80	1.15 (70%)- 1.18 (75%)	G/C	10,000	0.0011	75	7.5	0	1,385	115	135
HA-1/ HA-2	100 ft Downstream of Hwy 80 to downstream face of Ward	1.18 (25%)- 1.20	G/C	8,670	0.0033	75	7.3	0	415	105	125
HA-2	Downstream face of Ward St. to downstream face of Bosco	1.21-1.24	G/C	7,870	0.0036	75	6.7	0	1,170	102	120
	Downstream face of Bosco to 900 ft downstream of Lincoln	1.25-1.28	G/C	7,470	0.0034	70	6.9	2	1,250	97.5	115
	900 ft Downstream of Lincoln upstream face of Lincoln	1.29-1.30	G/C	7,070	0.0031	60	7.5	2	960	90	110
	Upstream face of Lincoln to downstream face of Kenwood	1.31-1.32	G/C	7,070	0.0025	65	7.6	0	475	95.5	115
HA-2/ HA-3	Downstream face of Kenwood to downstream face of Avenue B	1.33-1.34	G/C	4,710	0.0025	40	7.8	3	240	71.5	90
HA-3	Downstream face of Avenue B to downstream face Loop 281	1.35-1.38	G/C	4,710	0.002	45	7.9	2	525	76.5	95
	Downstream face Loop 281 to 1,300 ft upstream Loop 281	1.39-1.41	G/C	4,140	0.0033	40	6.8	3	1,475	67	95

B-18

TABLE B-8 (Cont'd)

CHANNEL DESIGN FEATURES - HARRIS CREEK/DRAIN NO. 4

Watershed Identification	Reach Location		Design Features					Number of Drops	Length (ft)	Top Width (ft)	Easement (ft)
	General Description	G.I.S. Nos.	Type	Discharge (cfs)	Slope (ft/ft)	Bottom Width (ft)	Depth (ft)				
HA-4	1,300 ft Upstream of Loop 281 to 2,400 ft upstream of Loop 281	1.42	G/C	3,510	0.0034	35	6.6	2	1,100	61.5	80
HA-4/ HA-5	2,400 ft Upstream of Loop 281 to 2,000 ft downstream of Reel Rd.	1.43-1.46	G/C	2,610	0.0043	30	5.3	2	1,400	51	70
HA-5	2,000 ft Downstream of Reel Rd. to downstream face of Reel Rd.	1.47-1.49	G	2,325	0.005	25	7.0	2	2,000	67	85
	Downstream face of Reel Rd. to 50 ft downstream of Evergreen	1.50-1.53 (90%)	G	2,040	0.0053	25	6.4	0	1,225	63.5	85
	50 ft Downstream of Evergreen to upstream face of Lynnwood	1.53 (10%)-1.60	G	1,355	0.0039	25	5.6	0	1,325	58.5	80
	Upstream face of Lynnwood to 40 ft downstream of Swan St.	1.61-1.63 (95%)	G	1,355	0.0065	20	5.4	2	945	52.5	60
	40 ft Downstream of Swan St. to 100 ft upstream of Swan St.	1.63 (5%)-1.65 (10%)	G	965	0.0024	15	4.8	0	190	44	55
	100 ft Upstream of Swan St. to 700 ft upstream of Swan St.	1.65 (60%)	G	965	0.0083	20	4.2	3	600	45	55
	700 ft Upstream of Swan St. to 1300 ft upstream of Swan St or Toe of Spillway	1.65 (30%)-1.66	G	965	0.0066	10	5.5	2	600	43	55
HA(T)-1	Harris Cr. to South Ward Dr.	16.01	G	1,340	0.01	35	3.8	0	560	57.5	80
	South Ward Dr. to 100 ft below Enterprise St.	16.02-16.07 (80%)	G	1,340	.011	35	3.7	3	1,940	57.0	75
HA(T)-2	From Harris Cr. to 400 ft above Harris Cr.	27.01 (40%)	G/C	1,040	0.004	30	3.9	0	500	45.5	65

B-19

TABLE B-8 (Cont'd)

CHANNEL DESIGN FEATURES - HARRIS CREEK/DRAIN NO. 4

Watershed Identification	Reach Location		Design Features					Number of Drops	Length (ft)	Top Width (ft)	Easement (ft)
	General Description	G.I.S. Nos.	Type	Discharge (cfs)	Slope (ft/ft)	Bottom Width (ft)	Depth (ft)				
HA(T)-2	From 400 ft above Harris Cr. to Rodden Dr.	27.01 (60%)- 27.02 A, B & C	G	1,040	0.007	25	4.2	0	480	50.5	70
	From Rodden Dr. to 700 ft above Rodden Dr.	27.03- 27.04 (50%)	G/C	1,040	0.004	15	5.1	2	720	35.5	45
HA(T)-3	Harris Creek to 150 ft below Rodden Dr.	29.01 (60%)	C	1,230	0.002	25	4.7	0	240	34.5	55
	150 ft below Rodden Dr. to 760 ft above Rodden Dr.	29.01 (40%)- 29.06 (30%)	G	1,230	0.009	25	4.3	0	1,060	51	70
	760 ft above Rodden Dr. to 1,250 ft above Rodden Dr.	29.06 (70%)- 29.07 (50%)	G	1,230	0.008	25	4.4	0	620	52	70
	1,250 ft above Rodden Dr. to Rainbow Dr.	29.07 (50%)- 29.10	G	1,230	0.010	20	4.6	0	440	47.5	60
Drain No. 4											
DR4-1	Confluence with Harris Creek 621 ft above Ave B	1.01- 1.03 (60%)	G/C	2,600	0.008	50	3.4	1	840	64	85
	621 ft above Ave B to 951 ft above Ave B	1.03 (40%)	G/C	2,600	0.0039	40	4.7	0	330	59	80
	951 ft above Ave B to 120 ft below Loop 281	1.04 (70%)	G/C	2,250	0.008	40	3.5	0	550	54	75
	120 ft below Loop 281 to 95 ft above Lane Wells	1.04 (30%)- 1.12 (10%)	G/C	1,630	0.008	30	3.4	0	1,770	44	65

B-20

TABLE B-8 (Concluded)

CHANNEL DESIGN FEATURES - HARRIS CREEK/DRAIN NO. 4

Watershed Identification	Reach Location		Design Features*					Number of Drops	Length (ft)	Top Width (ft)	Easement (ft)
	General Description	G.I.S. Nos.	Type	Discharge (cfs)	Slope (ft/ft)	Bottom Width (ft)	Depth (ft)				
DR4-1 (Cont'd)	From 95 ft above Lane Wells to 156 ft below Golfcrest	1.12 (90%)- 1.14 (50%)	G/C	1,310	0.008	12	5.3	0	820	32	40
	From 156 ft below Golfcrest to 127 ft above	1.14 (50%)- 1.16 (50%)	G/C	1,000	0.008	12	4.6	1	320	30	40
	127 ft above Golfcrest to Scenic Dr	1.16 (50%)- 1.19	N/I	1,000	0.0073				820		
	Scenic Dr to 292 ft above Scenic Dr	1.20- 1.21 (70%)	G/C	600	0.0014	15	5.0	1	292	35	50
	292 ft above Scenic Dr to Harroun Ct	1.21 (30%)- 1.24	G	650	0.008	15	3.9	0	960	38	50

Type: G - Grass
 C - Concrete
 G/C - Grass/Concrete
 N/I - No Improvement

B-21

TABLE B-9

CHANNEL DESIGN FEATURES - HAWKINS CREEK/LAFAMO CREEK

Watershed Identification	Reach Location		Design Features					Number of Drops	Length (ft)	Top Width (ft)	Required Easement (ft)
	General Description	G.I.S. Nos.	Type	Discharge (cfs)	Slope (ft/ft)	Bottom Width (ft)	Depth (ft)				
Hawkins Creek											
HK(T)-1	0 to 958 ft above Hawkins Creek	NA	G	6,870	0.004	120	6.6	0	958	159	180
	958 ft above Hawkins Creek to 160 ft above Dumas Road	NA	G	6,870	0.003	120	7.1	0	1,285	163	185
	160 ft to 3,088 ft above Dumas Road	NA	G	6,490	0.003	90	8.0	0	2,928	138	160
	3,088 ft above Dumas Road to Boyd Road	NA	G	5,570	0.003	90	7.4	0	2,047	134	155
	Boyd Road to 310 ft above Pine Tree Road	NA	G	3,420	0.004	70	5.9	0	1,546	105	125
	310 ft above Pine Tree Road to Greggtx Road	NA	G	3,420	0.006	55	5.9	0	1,060	90	110
	Greggtx Road to 2,302 ft above Greggtx Road	NA	G	3,040	0.005	55	5.8	0	2,302	90	110
	2,302 ft to 3,480 ft above Greggtx Road	NA	G	940	0.006	15	5.0	0	1,178	45	55
	3,480 ft to 4,079 ft above Greggtx Road	NA	G	940	0.011	15	4.3	2	599	41	50
	4,079 ft to 4,729 ft above Greggtx Road	NA	G	940	0.008	15	4.7	0	650	43	55
HK(T)-2	0 to 740 ft above Hawkins Creek	NA	G	2,050	0.007	45	4.7	0	740	73	95
	740 ft above Hawkins Creek to 250 ft below Greggtx Road	NA	G	2,050	0.008	40	4.8	0	635	69	90

B-22

TABLE B-9 (Cont'd)

CHANNEL DESIGN FEATURES - HAWKINS CREEK/LAFAMO CREEK

Watershed Identification	Reach Location		Design Features					Number of Drops	Length (ft)	Top Width (ft)	Required Easement (ft)
	General Description	G.I.S. Nos.*	Type	Discharge (cfs)	Slope (ft/ft)	Bottom Width (ft)	Depth (ft)				
HK(T)-2 (Cont'd)	60 ft to 250 ft below Greggtx Road	NA	G	1,800	0.005	40	5.0	2	190	70	90
	60 ft below Greggtx Road to 2,033 ft above Greggtx Road	NA	G	1,800	0.005	30	5.7	1	2,093	64	85
	2,033 ft to 2,583 ft above Greggtx Road	NA	G	1,200	0.009	30	3.9	0	550	54	75
	2,583 ft to 3,041 ft above Greggtx Road	NA	G	1,200	0.011	25	4.0	0	458	49	70
	3,041 ft to 4,162 ft above Greggtx Road	NA	G	1,200	0.008	20	4.8	1	1,121	49	60
HK(T)-3	0 to 480 ft above tributary mouth	NA	G	3,070	0.006	40	6.4	0	480	79	100
	480 ft to 2,188 ft above tributary mouth	NA	G	3,070	0.004	25	8.4	0	1,708	76	95
	2,188 ft to 2,979 ft above tributary mouth	NA	G	3,070	0.005	25	8.0	0	791	73	95
	2,979 ft to 3,520 ft above tributary mouth	NA	G	2,580	0.005	25	7.3	0	541	69	90
	3,520 ft to 4,424 ft above tributary mouth	NA	G	1,380	0.007	25	4.9	0	904	54	75
	4,424 ft to 5,790 ft above tributary mouth	NA	G	1,380	0.009	25	4.6	1	1,366	53	75
	5,790 ft to 6,510 ft above tributary mouth	NA	G	1,000	0.007	20	4.5	0	720	47	55

B-23

TABLE B-9 (Cont'd)

CHANNEL DESIGN FEATURES - HAWKINS CREEK/LAFAMO CREEK

Watershed Identification	Reach Location		Design Features					Number of Drops	Length (ft)	Top Width (ft)	Required Easement (ft)
	General Description	G.I.S. Nos.*	Type	Discharge (cfs)	Slope (ft/ft)	Bottom Width (ft)	Depth (ft)				
HK(T)-1A	Spring Hill Creek to Snoddy Road	NA	G	760	0.01	25	3.2	0	636	44	65
	0 to 1,113 ft above Snoddy Road	NA	G	760	0.01	25	3.2	2	1,113	44	65
HK(T)-1B	0 to 1,343 ft above mouth of Sara Creek	NA	G	1,950	0.006	55	4.3	0	1,343	81	100
	1,343 ft to 2,020 ft above mouth of Sara Creek	NA	G	1,950	0.010	55	3.7	1	677	77	95
	2,020 ft to 2m650 ft above mouth of Sara Creek	NA	G	770	0.006	20	4.1	0	630	45	55
	20 ft to 450 ft below Yarborough Road	NA	G	770	0.009	10	4.6	0	430	38	50
	450 ft below Yarborough Road to 1,232 ft above Yarborough Road	NA	G	770	0.013	10	4.2	1	1,252	35	45
HK(T)-1C	335 ft to 715 ft below Pine Tree Road	NA	G	940	0.008	30	3.6	0	380	51	70
	50 ft to 335 ft below Pine Tree Road	NA	G	940	0.014	30	3.0	1	285	48	70
	50 ft below Pine Tree Road to 431 ft above Pine Tree Road	NA	G	940	0.01	30	3.3	0	481	50	70
	431 ft to 691 ft above Pine Tree Road	NA	G	940	0.014	30	3.0	1	260	48	70
	691 ft to 2,014 ft above Pine Tree Road	NA	G	940	0.011	30	3.2	0	1,323	50	70

B-24

TABLE B-9 (Cont'd)

CHANNEL DESIGN FEATURES - HAWKINS CREEK/LAFAMO CREEK

Watershed Identification	Reach Location		Design Features					Number of Drops	Length (ft)	Top Width (ft)	Required Easement (ft)
	General Description	G.I.S. Nos.*	Type	Discharge (cfs)	Slope (ft/ft)	Bottom Width (ft)	Depth (ft)				
HK(T)-1D	0 to 170 ft above tributary mouth	NA	G	850	0.013	20	3.5	0	170	41	50
	170 ft to 823 ft above tributary mouth	NA	G	850	0.008	20	4.0	0	653	44	55
	823 ft to 1,208 ft above tributary mouth	NA	G	850	0.013	20	3.5	0	385	41	50
	1,208 ft to 1,858 ft above tributary mouth	NA	G	850	0.008	20	4.0	0	650	44	55
	1,858 ft to 2,085 ft above tributary mouth	NA	G	850	0.013	20	3.5	2	227	41	50
HK(T)-E	0 to 260 ft above tributary mouth	NA	G	610	0.02	25	2.4	2	260	39	60
	260 ft to 781 ft above tributary mouth	NA	G	610	0.008	10	4.2	0	521	36	45
LaFamo Creek											
LA-1	Oil Field Road upstream of Whately Road to 90 ft upstream of Chevron Lease Road	NA	G	6,290	0.0043	85	7.3	0	2,210	130	150
	90 ft upstream of Chevron Lease Road to 85 ft upstream of LaFamo Road	NA	G	6,030	0.0042	70	7.9	1	1,900	120	140
LA-2	85 ft upstream of LaFamo Road to 240 ft downstream of Oil Road	NA	G	3,120	0.0046	30	7.7	0	1,900	75	95
LA-3	240 ft downstream of Oil Road to 2,160 ft downstream of Annette Drive	NA	G	1,910	0.0075	30	5.3	2	1,970	60	80

B-25

TABLE B-9 (Cont'd)

CHANNEL DESIGN FEATURES - HAWKINS CREEK/LAFAMO CREEK

Watershed Identification	Reach Location		Design Features					Number of Drops	Length (ft)	Top Width (ft)	Required Easement (ft)
	General Description	G.I.S. Nos.	Type	Discharge (cfs)	Slope (ft/ft)	Bottom Width (ft)	Depth (ft)				
LA-3 (Cont'd)	2,160 ft downstream of Annette Drive to 500 ft downstream of Annette Drive	NA	G	1,450	0.0085	20	5.2	2	1,660	50	60
LA(T)-1A	0 to 2,000 ft above LaFamo Creek	NA	G	2,410	0.004	40	6.3	0	2,000	78	100
	2,000 ft to 2,820 ft above LaFamo Creek	NA	G	2,410	0.006	40	5.6	0	820	74	95
LA(T)-1A/ LA(T)-1B	2,820 ft to 3,840 ft above LaFamo Creek	NA	G	2,410	0.007	40	5.4	1	1,020	72	90
LA(T)-1B	3,840 ft to 4,265 ft above LaFamo Creek	NA	G	1,130	0.012	30	3.5	0	425	51	70
	2,600 ft to 3,210 ft below Stanolind Road	NA	G	1,130	0.008	30	3.9	0	615	54	74
	2,140 ft to 2,600 ft below Stanolind Road	NA	G	1,130	0.011	30	3.6	0	450	52	70
	1,880 ft to 2,140 ft below Stanolind Road	NA	G	1,130	0.012	30	3.5	0	265	51	70
	955 ft to 1,880 ft below Stanolind Road	NA	G	840	0.007	15	4.5	0	925	42	50
	730 ft to 955 ft below Stanolind Road	NA	G	840	0.012	15	4.0	1	225	39	50
	210 ft to 730 ft below Stanolind Road	NA	G	840	0.01	15	4.2	1	520	40	50
	210 ft below Stanolind Road to 200 ft above Stanolind Road	NA	G	840	0.012	15	4.0	1	410	39	50

B-26

TABLE B-9 (Concluded)

CHANNEL DESIGN FEATURES - HAWKINS CREEK/LAFAMO CREEK

Watershed Identification	Reach Location		Design Features					Number of Drops	Length (ft)	Top Width (ft)	Required Easement (ft)
	General Description	G.I.S. Nos.*	Type	Discharge (cfs)	Slope (ft/ft)	Bottom Width (ft)	Depth (ft)				
LA(T)-1C	0 to 70 ft above tributary mouth	NA	G	830	0.014	50	2.2	0	70	63	85
	70 ft to 250 ft above tributary mouth	NA	G	830	0.011	40	2.6	1	180	56	75
	250 ft to 720 ft above tributary mouth	NA	G	830	0.011	25	3.3	0	470	45	65
	720 ft to 1,350 ft above tributary mouth	NA	G	830	0.008	25	3.6	0	630	47	65
	1,350 ft to 1,950 ft above tributary mouth	NA	G	830	0.014	20	3.4	1	600	41	50
LA(T)-2	0 to 540 ft above LaFamo Creek	NA	G	630	0.014	25	2.7	1	540	41	60
	540 ft to 1,110 ft above LaFamo Creek	NA	G	630	0.009	20	3.3	0	560	40	50
	1,100 ft to 1,420 ft above LaFamo Creek	NA	G	630	0.016	20	2.8	0	320	37	45

Type: G - Grass
 C - Concrete
 G/C - Grass/Concrete
 N/I - No Improvement

* Due to a lack of knowledge of the drainage network, G.I.S. numbers were not assigned (NA) for the Hawkins Creek/LaFamo Creek watershed.

TABLE B-10

CHANNEL DESIGN FEATURES - IRON BRIDGE CREEK

Watershed Identification	Reach Location		Design Features					Number of Drops	Length (ft)	Top Width (ft)	Required Easement (ft)
	General Description	G.I.S. Nos.	Type	Discharge (cfs)	Slope (ft/ft)	Bottom Width (ft)	Depth (ft)				
Iron Bridge Creek											
IB-1	Santa Fe Railroad to IB(T)-1 Tributary	1.01A-1.01C	G	7,070	0.0034	50	11	0	1,100	115	135
IB(T)-1	Mouth to IH-20	2.01-2.14	G	2,800	0.005	20	9	0	6,400	75	85
	IH-20 to Pittman St.	No GIS Nos.	G	700	0.005	10	7.5	0	1,700	55	65
IB-2	IB(T)-1 Tributary to IH-20	1.02-1.06	G	4,760	0.0034	40	10	0	3,400	100	120
IB-3	IH-20 to Margo St.	1.07-1.16	G	4,410	0.0030	40	10	0	4,800	100	120
IB-4	Margo St. to Millie St.	1.17-1.20	C	3,500	0.0041	12	8.5	0	1,550	30	40
IB-5	Millie St. to Raney St.	1.21-1.36	N/I*	--	--	--	--	--	--	--	--
IB-6	Raney St. to 12th St.	1.37-1.43	C	2,180	0.0040	10	7	0	2,500	25	35
	12th St. to above Dean St.	1.44-1.48A	C	1,180	0.0060	10	5	0	1,650	20	30

Type:
 G - Grass
 C - Concrete
 G/C - Grass/Concrete
 N/I - No Improvement

* Note: No channel improvements from Millie St. to Raney St. (IB-5), however, enlarged bridge openings are proposed at Raney St., Wells St. and Lemmon St.

TABLE B-11

CHANNEL DESIGN FEATURES - JOHNSON CREEK

Watershed Identification	Reach Location		Design Features					Number of Drops	Length (ft)	Top Width (ft)	Required Easement (ft)
	General Description	G.I.S. Nos.	Type	Discharge (cfs)	Slope (ft/ft)	Bottom Width (ft)	Depth (ft)				
Johnson Creek											
JO-1	Confl. w/Guthrie to upstream face of Private Rd for Triple Creek Center	1.01-1.04	G/C	2,210	0.004	20	6.6	0	775	46	55
	Upstream face of Private Rd to 175 ft downstream of Hoyt Dr	1.05-1.06 (70%)	G/C	2,210	0.006	20	6.2	0	650	45	55
	175 ft downstream of Hoyt Dr to upstream of Hoyt Dr	1.06 (30%)-1.08A	C	2,210	0.0034	20	6.1	0	250	32	40
	Upstream face of Hoyt Dr to 250 ft upstream of Eden Dr	1.09-1.12 (20%)	C	2,210	0.003	15	7.2	2	720	29	40
	250 ft upstream of Eden Dr to 500 ft upstream of Eden Dr	1.12 (30%)	G/C	2,210	0.0052	15	7.2	1	250	44	55
	500 ft upstream of Eden Dr to 135 ft downstream of Delwood	1.12 (70%)-1.13 (60%)	G/C	1,960	0.0055	15	6.7	4	1,330	42	50
JO-2	135 ft downstream of Delwood to downstream face of Delwood	1.13 (40%)	C	1,230	0.003	10	6.4	1	135	23	35
	Downstream face of Delwood to 850 ft upstream of Delwood	1.14-1.15	N/I								
	850 ft upstream of Delwood upstream face of Hollybrook	1.16-1.19A	G	1,230	0.007	30	4.5	0	940	57	75
	Upstream face of Hollybrook to upstream face of Airline Rd	1.20-1.21	G	960	0.0045	25	4.6	0	640	53	75
	Upstream face of Airline Rd upstream face of Foot Bridge	1.22 (40%)	G/C	960	0.003	15	5.3	0	430	36	45
	Upstream face of Foot Bridge to upstream face of Drake Blvd	1.22 (60%)-1.23	C	960	0.007	15	3.5	0	590	22	30

B-29

TABLE B-11 (Concluded)

CHANNEL DESIGN FEATURES - JOHNSON CREEK

Watershed Identification	Reach Location		Design Features					Number of Drops	Length (ft)	Top Width (ft)	Required Easement (ft)
	General Description	G.I.S. Nos.	Type	Discharge (cfs)	Slope (ft/ft)	Bottom Width (ft)	Depth (ft)				
JO-2 (Cont'd)	Upstream face of Drake to 200 ft upstream of Drake	1.24	C	960	0.006	15	3.6	0	200	22	30
	200 ft upstream of Drake to 400 ft downstream of Commander	1.25 (50%)	C	960	0.0037	15	4.1	0	450	23	35
	400 ft downstream of Commander to 200 ft downstream of Commander	1.25 (25%)	C	960	0.005	15	3.8	1	200	23	35
	200 ft downstream of Commander to upstream face of Commander	1.25 (25%)- 1.26	C	960	0.006	15	3.6	0	200	22	30
	Upstream face of Commander to upstream face of Skyline Dr	1.27-1.28	C	480	0.0037	20	2.3	0	510	25	35
	Upstream face Skyline Dr to upstream face Loop 281	1.29-1.34	C	480	0.01	15	2.0	0	530	19	30
JO(T)-1	Johnson Creek to 220 ft above Johnson Creek	9.01 (70%)	G	740	0.009	15	4.0	0	220	39	50
	200 ft below Judson Road 550 ft above Judson Road	9.01 (30%)- 9.03 (90%)	C	740	0.003	15	3.7	2	830	22	30
	500 ft to 1,200 ft above Judson Road	9.03 (10%)- 9.06	G	740	0.012	10	4.2	1	850	35	45

Type: G - Grass
 C - Concrete
 G/C - Grass/Concrete
 N/I - No Improvement

B-30

TABLE B-12

CHANNEL DESIGN FEATURES - McCANN CREEK

Watershed Identification	Reach Location		Design Features					Number of Drops	Length (ft)	Top Width (ft)	Required Easement (ft)
	General Description	G.I.S. Nos.	Type	Discharge (cfs)	Slope (ft/ft)	Bottom Width (ft)	Depth (ft)				
McCann Creek											
MC-1	Confluence with Grace Creek to 100 ft downstream of Greystone Road	1.01 (95%)	G	3,330	0.0066	60	5.4	0	2,080	92	110
	100 ft downstream of Greystone Road to 400 ft upstream of Greystone Road	1.01 (5%)-1.03	G	3,060	0.0043	60	5.8	0	560	95	115
MC-2	400 ft to 1,310 ft upstream of Greystone Road	1.04 (55%)	G/C	2,340	0.0016	35	6.3	0	910	55	75
	1,310 ft upstream of Greystone Road to confluence with tributary MC(T)-2	1.04 (45%)	G	2,340	0.007	35	5.6	1	790	69	90
MC-3	Confluence with tributary MC(T)-2 to 850 ft downstream of confluence w/tributary MC(T)-3	1.05 (70%)	G	1,390	0.0066	20	5.4	0	1,850	52	60
	850 ft downstream of confluence with tributary MC(T)-3 to confluence with tributary MC(T)-3	1.05 (30%)	G	1,390	0.0093	20	5.0	0	850	50	60
MC-4	Tributary MC(T)-3 to 1,100 ft upstream of tributary MC(T)-3	1.06 (35%)	G	640	0.0108	10	4.1	0	1,100	35	45

B-31

TABLE B-12 (Concluded)
 CHANNEL DESIGN FEATURES - McCANN CREEK

Watershed Identification	Reach Location		Design Features					Number of Drops	Length (ft)	Top Width (ft)	Required Easement (ft)
	General Description	G.I.S. Nos.	Type	Discharge (cfs)	Slope (ft/ft)	Bottom Width (ft)	Depth (ft)				
MC(T)-1	Mouth of tributary MC(T)-1 to 470 ft upstream	2.01-2.02 (5%)	G	770	0.008	20	3.8	0	470	43	55
	470 ft to 1,330 ft above mouth of tributary MC(T)-1	2.02 (85%)	G	770	0.009	20	3.7	1	860	42	50
MC(T)-2	Mouth of tributary MC(T)-2 to 600 ft upstream	3.01 (50%)	G	700	0.009	20	3.5	0	600	41	50
	600 ft to 1,200 ft above mouth of tributary MC(T)-2	3.01 (50%)	G	700	0.008	20	3.6	0	600	42	50
	1,200 ft to 1,920 ft above mouth of tributary MC(T)-2	3.02 (40%)	G	700	0.007	15	4.2	0	720	40	50
	1,920 ft to 2,300 ft above mouth of tributary MC(T)-2	3.02 (20%)	G	700	0.013	5	4.7	1	380	33	45
MC(T)-3	Mouth of tributary MC(T)3 to 1,665 ft upstream	4.01-4.06 (30%)	G	500	0.012	5	4.1	0	1,665	30	40

B-32

Type:
 G - Grass
 C - Concrete
 G/C - Grass/Concrete
 N/I - No Improvement

TABLE B-13

CHANNEL DESIGN FEATURES - OAKLAND CREEK

Watershed Identification	Reach Location		Design Features					Number of Drops	Length (ft)	Top Width (ft)	Required Easement (ft)
	General Description	G.I.S. Nos.	Type	Discharge (cfs)	Slope (ft/ft)	Bottom Width (ft)	Depth (ft)				
Oakland Creek											
OA-1	Confl. w/Guthrie to 305 ft downstream of Hoyt Dr	1.01-1.03(60%)	G	7,090	0.0054	125	6.0	0	1,160	161	180
	305 ft downstream of Hoyt Dr to 80 ft upstream of Eden Dr	1.03 (40%)- 1.08 (20%)	C	7,090	0.002	50	8.0	0	860	66	85
OA-1/ OA-2	80 ft upstream of Eden Dr to downstream face of Delwood	1.08 (80%)- 1.13	G/C	6,600	0.003	55	7.6	1	1,640	85	105
	Downstream face of Delwood to 165 ft downstream of Hollybrook	1.14- 1.18 (60%)	G	4,700	0.005	75	6.4	0	2,245	113	135
	165 ft downstream of Hollybrook to 935 ft upstream of Hollybrook	1.18 (40%)- 1.20	G/C	4,700	0.0055	80	4.2	0	1,170	97	115
	935 ft upstream of Hollybrook to upstream face of 4th Street	1.21- 1.22	G/C	4,390	0.003	70	5.3	0	1,570	91	110
	Upstream face of 4th Street to upstream face of Loop 281	1.23- 1.25	G/C	3,880	0.002	55	6.3	0	2,250	80	100
OA-3	Upstream face of Loop 281 to 375 ft upstream of Loop 281	1.26 (35%)	G/C	2,160	0.0053	55	3.4	2	375	69	90
	375 ft upstream of Loop 281 to 1,525 ft upstream of Loop 281	1.26 (65%)- 1.27 (15%)	G/C	2,160	0.008	55	3.0	0	1,150	67	85
	1,525 ft upstream of Loop 281 to downstream face Hwy 259	1.27 (85%)	G	2,160	0.0053	40	5.5	1	2,445	73	95

B-33

TABLE B-13 (Concluded)

CHANNEL DESIGN FEATURES - OAKLAND CREEK

Watershed Identification	Reach Location		Design Features					Number of Drops	Length (ft)	Top Width (ft)	Required Easement (ft)
	General Description	G.I.S. Nos.	Type	Discharge (cfs)	Slope (ft/ft)	Bottom Width (ft)	Depth (ft)				
OA-3 (Cont'd)	Downstream face of Hwy 259 to 1,240 ft upstream of Hwy 259	N/A	G	1,260	0.006	25	4.9	0	1,400	54	75
OA(T)-1	Oakland Creek to 680 ft above Oakland Creek	17.01	G	1,760	0.007	55	3.9	0	680	78	100
	680 to 1,480 above Oakland Creek	17.02 A & B	N/I						800		
	1,480 ft to 2,090 ft above Oakland Creek	17.03 (40%)	G	1,250	0.01	30	3.9	1	610	53	75
	2,090 ft to 2,900 ft above Oakland Creek	17.03 (60%)	G	1,250	0.009	10	5.8	4	810	45	55

Type:
 G - Grass
 C - Concrete
 G/C - Grass/Concrete
 N/I - No Improvement

B-34

TABLE B-14

CHANNEL DESIGN FEATURES - PETERSON COURT CREEK

Watershed Identification	Reach Location		Design Features					Number of Drops	Length (ft)	Top Width (ft)	Required Easement (ft)
	General Description	G.I.S. Nos.	Type	Discharge (cfs)	Slope (ft/ft)	Bottom Width (ft)	Depth (ft)				
Peterson Court Creek											
PC-1	Around LeTourneau Plant	1.06(30%)	3-72" RCP	2471	0.0045	--	--	--	1,150	--	--
	Above LeTourneau Plant to High Street	1.06 (30%)-1.10	C	2471	0.0037	10	6.9	1	1,650	38	50
	High Street to Green Street	1.11-1.14	C	1,857	0.0045	10	5.8	2	1,000	34	45
	Green Street to Glen Street	1.15-1.17	C	1,166	0.0065	10	4.2	1	650	28	40
	Glen Street To Birdsong Street	1.18-1.24	C	1,000	0.007	8	3.8	0	1,400	24	35

Type: G - Grass
 C - Concrete
 G/C - Grass/Concrete
 N/I - No Improvement

B-35

TABLE B-15
CHANNEL DESIGN FEATURES - RAY CREEK

Watershed Identification	Reach Location		Design Features					Number of Drops	Length (ft)	Top Width (ft)	Required Easement (ft)
	General Description	G.I.S. Nos.	Type	Discharge (cfs)	Slope (ft/ft)	Bottom Width (ft)	Depth (ft)				
Ray Creek											
RA-1A/ RA-1B	Confluence with Grace Creek to Hawkins Pkwy (no improvements)	1.01 (60%)	N/I	--	--	--	--	--	2,250	--	--
RA-1B	Hawkins Pkwy to McCann Road	1.01 (40%)- 1.04	G/C	8,827	0.0026	68	8.1	0	1,850	103	125
	McCann Road to 2,200 ft above McCann Road	1.05- 1.06	G/C	8,582	0.0026	70	8.4	1	2,200	99	120
RA-1B/ RA-2	2,200 ft above McCann Road to 4,060 ft above McCann Road	1.07- 1.09	G/C	8,339	0.0026	65	8.3	0	1,840	98	120
RA-3/ RA-4	4,060 ft above McCann Road to Plier Precise Road	1.10- 1.14	G/C	5,737	0.0026	65	6.7	1	3,140	92	110
RA-4/ RA-5	Plier Precise Road to 2,400 ft above Plier Precise Road	1.15- 1.18	G	3,993	0.0057	65	6.0	2	2,400	101	120
	2,400 ft above Plier Precise Road to 3,540 ft above Plier Precise Road	1.19- 1.20	G	3,204	0.0057	50	6.0	2	1,140	86	105
RA-5/ RA-6/ RA-7	3,540 ft above Plier Precise Road to 5,380 ft above Plier Precise Road	1.21- 1.23 (30%)	G	1,596	0.008	15	6.0	3	1,830	51	60
RA-7	5,380 ft above Plier Precise to 350 ft above McCann Road	1.23 (70%)- 1.26 (10%)	G	580	0.004	25	3.6	0	3,200	46	65
	350 ft above McCann Road to 450 ft above McCann Road	1.26 (30%)	G	580	0.017	15	3.0	1	100	33	45
RA(T)-1	Ray Creek to 900 ft above Ray Creek	6.01- 6.03 (25%)	G	1,080	0.006	30	4.1	2	900	55	75

B-36

TABLE B-15 (Concluded)
CHANNEL DESIGN FEATURES - RAY CREEK

Watershed Identification	Reach Location		Design Features					Number of Drops	Length (ft)	Top Width (ft)	Required Easement (ft)
	General Description	G.I.S. Nos.	Type	Discharge (cfs)	Slope (ft/ft)	Bottom Width (ft)	Depth (ft)				
RA(T)-2	Ray Creek to 600 ft above Ray Creek	8.01 (60%)	C	1,220	0.002	25	4.2	1	600	33	55
	600 ft above Ray Creek to 900 ft above Ray Creek	8.01 (40%) 8.02 (40%)	G	1,220	0.010	20	4.6	0	900	48	60
RA(T)-3	Ray Creek to 130 ft above Ray Creek	13.01 (15%)	G	990	0.008	25	4.0	0	130	49	70
	130 ft above Ray Creek to 500 ft above Ray Creek	13.01 (55%)	G	990	0.013	25	3.5	0	385	46	65
RA(T)-4	Ray Creek to 1,260 ft above Ray Creek	16.01	G	1,520	0.008	40	4.0	0	1,260	39	60
RA(T)-5	Ray Creek to 830 ft above Ray Creek	18.01	G	510	0.008	10	3.9	0	830	33	45

Type:
 G - Grass
 C - Concrete
 G/C - Grass/Concrete
 N/I - No Improvement

B-37

TABLE B-16

CHANNEL DESIGN FEATURES - SCHOOL BRANCH/DRAIN NO. 3

Watershed Identification	Reach Location		Design Features					Number of Drops	Length (ft)	Top Width (ft)	Required Easement (ft)
	General Description	G.I.S. Nos.	Type	Discharge (cfs)	Slope (ft/ft)	Bottom Width (ft)	Depth (ft)				
School Branch											
SB-1A	Confluence with Grace to Oak Forest CC Dr.	1.01-1.02 (50%)	N/I	--	--	--	--	--	810	--	--
SB-1A/ SB-1B	Oak Forest CC Dr. 3000 ft upstream to dirt road	1.02 (50%)-1.06 (50%)	G/C	6,649	0.003	45	8.0	2	3,000	77	95
SB-1B	Dirt road upstream 600 ft	1.06 (50%)-1.08	G/C	6,000	0.003	40	8.0	0	6,000	72	90
SB-2	Confluence with Drain No. 3 to Bill Owens Parkway	1.09-1.15	G	3,225	0.0045	30	8.0	1	3,470	78	100
	Bill Owens Parkway to 1,900 ft above Bill Owens Parkway	1.16-1.19 (69%)	G	2,752	0.0045	25	7.8	1	1,900	72	90
	1,900 ft above Bill Owens to 6,219 ft above Bill Owens	1.19 (31%)-1.26	G	1,829	0.0038	15	7.6	1	4,320	61	70
SB(T)-1	School Branch to 440 ft above School Branch	2.01 (40%)	G	500	0.015	10	3.3	1	440	30	40
	440 ft above School Branch to 800 ft above School Branch	2.01 (30%)	G	500	0.014	5	4.0	2	360	29	40
	800 ft above School Branch to Bill Owens Parkway	2.01 (30%)	G	500	0.16	5	3.8	1	250	28	40
DR3-1	Confluence with School Branch to 1,620 ft above confluence	1.01-1.08	G	2,872	0.0038	30	7.8	0	1,620	77	95

B-38

TABLE B-16 (Concluded)

CHANNEL DESIGN FEATURES - SCHOOL BRANCH/DRAIN NO. 3

Watershed Identification	Reach Location		Design Features					Number of Drops	Length (ft)	Top Width (ft)	Required Easement (ft)
	General Description	G.I.S. Nos.	Type	Discharge (cfs)	Slope (ft/ft)	Bottom Width (ft)	Depth (ft)				
DR3-1 (Cont'd)	1,620 ft above confluence to Camille Drive	1.09-1.14	G	2,271	0.002	30	8.1	0	1,760	79	100
	Camille Drive to 2,788 ft below Gilmer Road	1.15-1.17	G	2,271	0.0054	20	7.2	0	1,170	63	75
	2,788 ft below Gilmer Road to Gilmar Road	1.18-1.25	G	1,495	0.008	10	6.4	4	2,790	48	60

Type: G - Grass
 C - Concrete
 G/C - Grass/Concrete
 N/I - No Improvement

B-39

TABLE B-17
CHANNEL DESIGN FEATURES - WADE CREEK

Watershed Identification	Reach Location		Design Features					Number of Drops	Length (ft)	Top Width (ft)	Required Easement (ft)
	General Description	G.I.S. Nos.	Type	Discharge (cfs)	Slope (ft/ft)	Bottom Width (ft)	Depth (ft)				
Wade Creek											
WD-1	Confluence w/Grace Creek to upstream face of Garfield Road	1.01-1.04	C	6,700	0.001	35	11.5	0	3,475	58	80
	Upstream face of Garfield to 1080 ft upstream of Garfield	1.05-1.06 (5%)	C	6,700	0.0016	50	8.3	0	1,080	67	85
WD-1/ WD-2	1080 ft upstream of Garfield to Upstream face RR Loop	1.06 (95%)- 1.08	G	5,930	0.003	50	10.0	0	1,565	110	130
WD-2	Upstream face RR Loop to Downstream face of High St.	1.09-1.12	N/I	--	--	--	--	--	--	--	--
	Downstream face of High St. to Downstream face of Fredonia	1.13-1.15	G	5,310	0.003	35	10.7	0	1,220	99	120
	Downstream face of Fredonia to Downstream face of Green St.	1.16-1.18	C	5,310	0.002	40	7.7	2	1,295	55	75
WD-2/ WD-3	Downstream face of Green St. to 90 ft Downstream of King St.	1.19-1.20	C	4,690	0.0035	40	6.0	1	930	52	70
WD-3	90 ft Downstream of King St. to 420 ft Upstream of King St.	1.21- 1.23 (50%)	C	3,180	0.0035	40	4.8	1	550	50	70
	420 ft Upstream of King St. to Downstream face of Mobberly	1.23 (50%)- 1.25	C	2,690	0.0035	30	5.1	1	930	40	60
	Downstream face of Mobberly to Downstream face of Timpson	1.26-1.34	C	2,310	0.004	30	4.5	1	1,185	39	60
	Downstream face of Timpson to Downstream face of Cotton	1.35-1.40	C	1,950	0.005	30	3.8	1	895	38	55
	Downstream face of Cotton to 675 ft Upstream of Cotton	1.41- 1.42 (30%)	C	1,470	0.006	30	3.0	1	725	36	55

B-40

TABLE B-17 (Concluded)

CHANNEL DESIGN FEATURES - WADE CREEK

Watershed Identification	Reach Location		Design Features					Number of Drops	Length (ft)	Top Width (ft)	Required Easement (ft)
	General Description	G.I.S. Nos.	Type	Discharge (cfs)	Slope (ft/ft)	Bottom Width (ft)	Depth (ft)				
WD-3 (Cont'd)	675 ft Upstream of Cotton to 225 ft Upstream Union Pacific RR	1.42 (70%)- 1.44	G/C	1,470	0.011	40	2.5	0	1,515	55	75
	225 ft Upstream of Union Pacific RR to Upstream face of Whaley St.	1.45-1.46	G	1,470	0.007	15	6.0	1	695	51	60
WD(T)-1	Wade Creek to 330 ft above Wade Creek	5.01 (50%)	G/C	1,030	0.003	10	6.4	0	330	30	40
	330 ft above Wade Creek to 150 ft below South High St.	5.01 (50%)- 5.04 (90%)	G/C	1,030	0.004	10	6.0	5	1,870	29	40
	150 ft below South High St. to 100 ft below Flanagan Dr.	5.04 (10%)- 5.09 (50%)	G/C	760	0.004	10	5.2	4	1,545	26	35
WD(T)-2	Wade Creek to 250 ft below San Jacinto Street	17.01- 17.05 (50%)	G/C	1,710	0.004	30	4.6	1	750	44	65
	250 ft below San Jacinto Street to Cotton Street	17.05 (50%)- 17.09	C	1,710	0.002	15	6.7	2	1,050	29	40
	Cotton Street to 300 ft above Cotton Street	17.43- 17.46 (50%)	G/C	1,710	0.004	15	6.5	1	515	36	45
	300 ft above Cotton Street to Texas and Pacific RR	N/A	G/C	1,710	0.004	15	6.5	0	840	36	45
	Texas and Pacific RR to Methvin St.	N/A	G	1,020	0.004	10	6.3	6	1,520	48	60

Type: G - Grass
C - Concrete
G/C - Grass/Concrete
N/I - No Improvement

APPENDIX C

Quantity and Cost for Channel
and Roadway Crossing Improvements

Note: Costs for roadway crossing improvements are based on the area of bridge deck [road width x (bridge length + 5 feet)]. If the road width is greater than 50 feet, unit cost of \$40 per square foot was used, otherwise the unit cost was \$35 per square foot. Road crossing openings to carry the design discharge are equivalent in size to the adjacent channel design configurations.

APPENDIX C
LIST OF TABLES

<u>Table</u>		<u>Page</u>
C-1	Coushatta Hills Creek	C-1
C-2	Drain No. 2/Oak Branch/Murray Creek	C-2
C-3	Eastman Lake Creek/Drain No. 1	C-4
C-4	Elm Branch	C-7
C-5	Gilmer Creek	C-8
C-6	Grace Creek	C-9
C-7	Guthrie Creek	C-13
C-8	Harris Creek/Drain No. 4	C-15
C-9	Hawkins Creek/LaFamo Creek	C-18
C-10	Iron Bridge Creek	C-22
C-11	Johnson Creek	C-23
C-12	McCann Creek	C-25
C-13	Oakland Creek	C-26
C-14	Peterson Court Creek	C-27
C-15	Ray Creek	C-28
C-16	School Branch/Drain No. 3	C-30
C-17	Wade Creek	C-31

APPENDIX C
SUMMARY OF COSTS
FOR
CHANNEL AND ROADWAY CROSSING IMPROVEMENTS

Table No.	Watershed	Cost
C-1	Coushatta Hills Creek	\$ 1,573,664
C-2	Drain No. 2/Oak Branch/Murray Creek	6,005,961
C-3	Eastman Lake Creek/Drain No. 1	9,900,071
C-4	Elm Branch	782,687
C-5	Gilmer Creek	3,583,701
C-6	Grace Creek	31,742,107
C-7	Guthrie Creek	8,237,440
C-8	Harris Creek/Drain No. 4	15,640,539
C-9	Hawkins Creek/LaFamo Creek	5,167,987
C-10	Iron Bridge Creek	4,499,945
C-11	Johnson Creek	2,664,490
C-12	McCann Creek	777,785
C-13	Oakland Creek	8,005,012
C-14	Peterson Court Creek	2,613,161
C-15	Ray Creek	369,376
C-16	School Branch/Drain No. 3	4,224,930
C-17	Wade Creek	<u>9,429,697</u>
	GRAND TOTAL	<u>\$ 115,218,553</u>

TABLE C-1
CHANNEL QUANTITY AND COST CALCULATIONS
COUSHATTA HILLS CREEK WATERSHED

WATERSHED	TYPE	LENGTH (FEET)	BOTTOM WIDTH (FEET)	DEPTH (FEET)	NUMBER DROPS	UNIT CONC. (CY/LF)	UNIT SEEDING (SF/LF)	EXCAVATION (CY)	DROP CONC. (CY)	CHANNEL CONC. (CY)	TOTAL SEEDING (SF)	COST CONC.	COST SEEDING	COST CUT/FILL	COST TOTAL
COUSHATTA HILLS CREEK															
CH-1	1	1930	15	7.10	3	0.65	0.00	13800	146.25	1250.16	0	\$418,922.25	\$0.00	\$54,400.00	\$473,322.25
CH-1	1	315	15	5.70	1	0.57	0.00	1000	48.75	181.11	0	\$68,957.78	\$0.00	\$4,000.00	\$72,957.78
CH-1	1	900	10	6.30	1	0.51	0.00	1100	32.5	461.97	0	\$146,341.00	\$0.00	\$4,400.00	\$152,741.00
CH-1	1	2178	10	4.30	4	0.41	0.00	2300	130	890.64	0	\$306,191.04	\$0.00	\$9,200.00	\$315,391.04
* TOTAL COSTS =												\$942,412.07	\$0.00	\$72,000.00	\$1,573,864.48

BREAKDOWN OF ROAD CROSSING COSTS

ROAD CROSSING	DESIGN SECTION	ROAD WIDTH (FEET)	BRIDGE LENGTH (FEET)	ROAD CROSSING COST
DELWOOD DR	CH-1	53	29	\$72,080.00
FLEETWOOD DR	CH-1	33	29	\$39,270.00
N. FOURTH ST	CH-1	66	29	\$69,760.00
SEQUOYAH LN	CH-1	33	26	\$35,805.00
NAVAJO	CH-1	33	23	\$32,340.00
PACHET	CH-1	33	19	\$27,720.00
TOTAL COSTS =				\$296,975.00

* TOTAL COSTS OF EACH WATERSHED INCLUDES BRIDGE COST PLUS 20% CONTINGENCY AND ENGINEERING FEE

NOTES:

- 1) TYPE = CHANNEL MATERIAL, WHERE: 1- CONCRETE, 2- GRASS/CONCRETE, 3- GRASS, 4- NO IMPROVEMENT
- 2) CY/LF = CUBIC YARD/LINEAR FOOT
- 3) SF/LF = SQUARE FOOT/LINEAR FOOT

01

TABLE C-2
CHANNEL QUANTITY AND COST CALCULATIONS
DRAIN NO. 2/ OAK BRANCH/ MURRAY CREEK

WATERSHED	TYPE	LENGTH (FEET)	BOTTOM WIDTH	DEPTH	NUMBER DROPS	UNIT CONC. (CY/LF)	UNIT SEEDING (SF/LF)	EXCAVATION (CY)	DROP CONC. (CY)	CHANNEL CONC. (CY)	TOTAL SEEDING (SF)	COST CONC.	COST SEEDING	COST CUT/FILL	COST TOTAL
DRAIN NO. 2															
DR2-1A	4	0	0	0.00	0	0.00	0.00	0	0	0.00	0	\$0.00	\$0.00	\$0.00	\$0.00
DR2-1B	2	580	85	6.50	0	1.75	20.55	18320	0	978.57	11511	\$293,571.80	\$895.28	\$85,280.00	\$359,746.88
DR2-1B	2	600	85	9.20	0	1.45	29.09	7500	0	867.75	17456	\$260,325.00	\$1,357.67	\$30,000.00	\$291,682.67
DR2-1B	2	160	60	8.60	0	1.34	27.20	1900	0	214.05	4351	\$64,214.40	\$338.43	\$7,600.00	\$72,152.83
* TOTAL COSTS =												\$618,111.00	\$2,591.38	\$102,880.00	\$1,886,394.86
OAK BRANCH															
OB-1	2	1730	60	8.40	2	1.33	26.56	25200	420	2305.40	45954	\$817,619.40	\$3,574.22	\$100,800.00	\$921,993.62
OB-1	3	910	45	8.40	0	0.00	85.00	3700	0	0.00	77350	\$0.00	\$6,016.11	\$14,800.00	\$20,816.11
OB-1	3	660	45	8.20	0	0.00	83.75	2300	0	0.00	55275	\$0.00	\$4,299.17	\$9,200.00	\$13,499.17
OB-1	2	240	45	5.20	0	0.97	16.44	1300	0	233.00	3947	\$69,901.20	\$306.95	\$5,200.00	\$75,408.15
OB-1	2	670	50	6.10	0	1.09	19.29	3300	0	728.36	12924	\$218,507.10	\$1,005.22	\$13,200.00	\$232,712.32
OB-1	2	950	50	6.00	0	1.08	18.97	6600	0	1030.28	18025	\$309,082.50	\$1,401.94	\$26,400.00	\$336,884.44
OB-1	3	925	45	6.10	1	0.00	83.13	4000	270	0.00	78691	\$81,000.00	\$5,960.38	\$16,000.00	\$102,960.38
OB-1	3	790	30	5.50	0	0.00	64.38	14465	0	0.00	50856	\$0.00	\$3,955.49	\$57,880.00	\$61,815.49
OB-1	3	880	30	5.00	0	0.00	61.25	11835	0	0.00	40425	\$0.00	\$3,144.17	\$47,340.00	\$50,484.17
OB-1	3	520	30	5.30	0	0.00	63.13	3300	0	0.00	32825	\$0.00	\$2,553.06	\$13,200.00	\$15,753.06
OB-1	3	310	30	5.10	0	0.00	61.88	1800	0	0.00	19181	\$0.00	\$1,491.67	\$7,200.00	\$8,691.67
OB-1	3	1780	30	5.10	0	0.00	61.88	4200	0	0.00	110138	\$0.00	\$8,586.25	\$16,800.00	\$25,386.25
OB-1	3	600	30	5.30	0	0.00	63.13	400	0	0.00	37875	\$0.00	\$2,945.83	\$1,600.00	\$4,545.83
OB-1	3	950	15	5.80	0	0.00	51.25	2800	0	0.00	48688	\$0.00	\$3,788.81	\$10,400.00	\$14,188.81
OB-1	3	670	5	5.20	1	0.00	37.50	2800	30	0.00	25125	\$9,000.00	\$1,954.17	\$11,200.00	\$22,154.17
OB-1	3	260	5	5.50	1	0.00	39.38	1000	30	0.00	10236	\$9,000.00	\$796.25	\$4,000.00	\$13,796.25
* TOTAL COSTS =												\$1,514,110.20	\$51,777.88	\$355,200.00	\$2,742,687.89
MURRAY CREEK															
MU-1	3	1250	60	8.70	0	0.00	114.38	900	0	0.00	142969	\$0.00	\$11,119.79	\$3,600.00	\$14,719.79
MU-1	3	100	50	8.60	0	0.00	103.75	200	0	0.00	10375	\$0.00	\$806.94	\$600.00	\$1,606.94
MU-1	3	935	50	7.70	0	0.00	96.13	2800	0	0.00	91747	\$0.00	\$7,135.67	\$11,200.00	\$18,335.67
MU-2	2	600	55	4.50	1	1.14	14.23	3400	192.5	683.01	8536	\$262,653.00	\$664.08	\$13,600.00	\$276,917.08
MU-2	3	1600	30	6.00	0	0.00	67.50	3900	0	0.00	106000	\$0.00	\$8,400.00	\$15,600.00	\$24,000.00
MU-2	3	1530	30	4.50	0	0.00	58.13	5600	0	0.00	88931	\$0.00	\$6,916.86	\$22,400.00	\$29,316.86
MU-2	3	1650	25	4.50	0	0.00	53.13	4500	0	0.00	87658	\$0.00	\$6,817.71	\$18,000.00	\$24,817.71
MU-2	3	70	20	5.20	1	0.00	52.50	200	120	0.00	3675	\$36,000.00	\$285.83	\$600.00	\$37,085.83
MU-2	3	500	20	5.40	0	0.00	53.75	4600	0	0.00	26875	\$0.00	\$2,090.28	\$18,400.00	\$20,490.28
MU-2	3	320	15	4.80	0	0.00	45.00	2400	0	0.00	14400	\$0.00	\$1,120.00	\$9,600.00	\$10,720.00
MU-2	3	900	15	4.70	0	0.00	44.38	1000	0	0.00	39936	\$0.00	\$3,106.25	\$4,000.00	\$7,106.25
* TOTAL COSTS =												\$298,653.00	\$48,483.63	\$118,000.00	\$1,052,347.85

C-2

TABLE C-2
CHANNEL QUANTITY AND COST CALCULATIONS
DRAIN NO. 2/ OAK BRANCH/ MURRAY CREEK

TRIBUTARY INFORMATION

WATERSHED	TYPE	LENGTH (FEET)	BOTTOM WIDTH (FEET)	DEPTH (FEET)	NUMBER DROPS	UNIT CONC. (CY/LF)	UNIT SEEDING (SF/LF)	EXCAVATION (CY)	DROP CONC. (CY)	CHANNEL CONC. (CY)	TOTAL SEEDING (SF)	COST CONC.	COST SEEDING	COST CUT/FILL	COST TOTAL
MU(T)-1	2	1190	25	3.70	0	0.58	11.70	485	0	888.94	13924	\$200,080.85	\$1,062.94	\$1,940.00	\$203,103.59
	3	1850	20	4.20	0	0.00	48.25	1671	0	0.00	85563	\$0.00	\$6,854.88	\$6,884.00	\$13,338.88
	3	800	10	3.80	0	0.00	32.50	892	0	0.00	26000	\$0.00	\$2,022.22	\$3,568.00	\$5,590.22
* TOTAL COSTS =												\$200,080.85	\$9,780.02	\$12,192.00	\$268,439.21
MU(T)-1A	3	880	20	4.07	1	0.00	45.44	1928	120	0.00	39076	\$38,000.00	\$3,039.28	\$7,704.00	\$46,743.28
* TOTAL COSTS =												\$38,000.00	\$3,039.28	\$7,704.00	\$56,091.92
TOTAL WATERSHED COST															
* TOTAL COSTS =												\$2,066,954.85	\$115,632.17	\$595,976.00	\$6,005,961.63

BREAKDOWN OF ROAD CROSSING COSTS

ROAD CROSSING	DESIGN SECTION	ROAD WIDTH (FEET)	BRIDGE LENGTH (FEET)	ROAD CROSSING COST
McCANN ST	DR2-1B	66	111	\$306,240.00
W HAWKINS	DR2-1B	66	102	\$282,480.00
JUDSON/SPUR 502	DR2-1B	66	94	\$281,360.00
TOTAL COSTS =				\$850,080.00
HILL ST	OB-1	33	88	\$82,005.00
AIRLINE RD	OB-1	66	81	\$174,240.00
HWY 259	OB-1	66	36	\$108,240.00
TOTAL COSTS =				\$364,485.00
AIRLINE	MU-1	66	102	\$282,480.00
HWY 259	MU-2	66	44	\$128,360.00
TOTAL COSTS =				\$411,840.00

* TOTAL COSTS OF EACH WATERSHED INCLUDES BRIDGE COST PLUS 20% CONTINGENCY AND ENGINEERING FEE

NOTES:

- 1) TYPE = CHANNEL MATERIAL, WHERE: 1- CONCRETE, 2- GRASS/CONCRETE, 3- GRASS, 4- NO IMPROVEMENT
- 2) CY/LF = CUBIC YARDS/LINEAR FOOT
- 3) SF/LF = SQUARE FEET/LINEAR FOOT

TABLE C-3
CHANNEL QUANTITY AND COST CALCULATIONS
EASTMAN LAKE CREEK/ DRAIN NO. 1

WATERSHED	TYPE	LENGTH (FEET)	BOTTOM WIDTH (FEET)	DEPTH (FEET)	NUMBER DROPS	UNIT CONC. (CY/LF)	UNIT SEEDING (SF/LF)	EXCAVATION (CY)	DROP CONC. (CY)	CHANNEL CONC. (CY)	TOTAL SEEDING (SF)	COST CONC.	COST SEEDING	COST CUT/FILL	COST TOTAL
EASTMAN LAKE CREEK/ DRAIN NO. 1															
EA -1 to EA-7 & DR1-1 (26%)	3	21800	80		0	0.00	80.00	554300	0	0.00	3246300	\$0.00	\$252,490.00	\$2,217,200.00	\$2,469,690.00
EA-8	3	6100	20	6	0	0.00	57.50	7800	0	0.00	350750	\$0.00	\$27,280.56	\$31,200.00	\$58,480.56
DR1-1 (74%)	3	3500	80	6	0	0.00	117.50	68900	0	0.00	411250	\$0.00	\$31,966.11	\$275,800.00	\$307,566.11
DR1-2	3	1900	80	6	0	0.00	117.50	42200	0	0.00	223250	\$0.00	\$17,363.69	\$168,800.00	\$186,163.69
DR1-3	3	3700	80	6	0	0.00	117.50	62700	0	0.00	434750	\$0.00	\$33,613.89	\$250,800.00	\$284,613.89
DR1-4	3	1600	50	6	0	0.00	87.50	1300	0	0.00	140000	\$0.00	\$10,668.89	\$5,200.00	\$16,068.89
DR1-4	3	2800	20	6	0	0.00	57.50	11300	0	0.00	161000	\$0.00	\$12,522.22	\$45,200.00	\$57,722.22
* TOTAL COSTS=												\$0.00	\$386,345.56	\$2,994,000.00	\$5,378,556.87

TRIBUTARY INFORMATION

WATERSHED	TYPE	LENGTH (FEET)	BOTTOM WIDTH (FEET)	DEPTH (FEET)	NUMBER DROPS	UNIT CONC. (CY/LF)	UNIT SEEDING (SF/LF)	** EXCAVATION (CY)	DROP CONC. (CY)	CHANNEL CONC. (CY)	TOTAL SEEDING (SF)	COST CONC.	COST SEEDING	COST CUT/FILL	COST TOTAL
EA(T)-1	3	1800	10	6	0	0.00	47.50		0	0.00	85500	\$0.00	\$6,850.00	\$0.00	\$6,850.00
EA(T)-1	3	550	5	5	0	0.00	36.25	9300	0	0.00	19938	\$0.00	\$1,550.69	\$37,200.00	\$38,750.69
* TOTAL COSTS=												\$0.00	\$8,200.69	\$37,200.00	\$201,480.83
EA(T)-2	3	3200	60	5	0	0.00	91.25	35900	0	0.00	292000	\$0.00	\$22,711.11	\$143,800.00	\$166,311.11
EA(T)-2	3	1500	20	5.5	0	0.00	54.38		0	0.00	81563	\$0.00	\$6,343.75	\$0.00	\$6,343.75
EA(T)-2	3	1900	10	5.5	0	0.00	44.38	20400	0	0.00	84313	\$0.00	\$6,557.64	\$61,600.00	\$68,157.64
* TOTAL COSTS=												\$0.00	\$35,612.50	\$225,200.00	\$362,275.00
EA(T)-3	3	3200	10	6	0	0.00	47.50		0	0.00	152000	\$0.00	\$11,822.22	\$0.00	\$11,822.22
EA(T)-3	3	700	5	5.5	0	0.00	36.38	14800	0	0.00	27583	\$0.00	\$2,143.75	\$59,200.00	\$61,343.75
* TOTAL COSTS=												\$0.00	\$13,965.97	\$59,200.00	\$69,439.17
EA(T)-4	3	2300	50	7	0	0.00	93.75		0	0.00	215825	\$0.00	\$16,770.83	\$0.00	\$16,770.83
EA(T)-4	3	900	35	7	0	0.00	78.75	51200	0	0.00	70675	\$0.00	\$5,512.50	\$204,800.00	\$210,312.50
EA(T)-4	1	2500	20	6.5	0	0.71	0.00		0	1773.50	0	\$532,050.00	\$0.00	\$0.00	\$532,050.00
EA(T)-4	1	2000	10	6	0	0.50	0.00	19000	0	995.40	0	\$288,620.00	\$0.00	\$78,000.00	\$374,620.00
* TOTAL COSTS=												\$830,670.00	\$22,283.33	\$280,800.00	\$1,957,744.00
EA(T)-5	3	900	10	6	0	0.00	47.50	8100	0	0.00	42750	\$0.00	\$3,325.00	\$32,400.00	\$35,725.00
* TOTAL COSTS=												\$0.00	\$3,325.00	\$32,400.00	\$42,870.00
EA(T)-6	3	2400	15	6	0	0.00	52.50		0	0.00	126000	\$0.00	\$9,800.00	\$0.00	\$9,800.00
EA(T)-6	1	650	10	6	0	0.50	0.00	17900	0	323.51	0	\$97,051.50	\$0.00	\$71,600.00	\$168,651.50
* TOTAL COSTS=												\$97,051.50	\$9,800.00	\$71,600.00	\$325,021.80

TABLE C-3
CHANNEL QUANTITY AND COST CALCULATIONS
EASTMAN LAKE CREEK/ DRAIN NO. 1

WATERSHED	TYPE	LENGTH (FEET)	BOTTOM WIDTH (FEET)	DEPTH (FEET)	NUMBER DROPS	UNIT CONC. (CY/LF)	UNIT SEEDING (SF/LF)	** EXCAVATION (CY)	DROP CONC. (CY)	CHANNEL CONC. (CY)	TOTAL SEEDING (SF)	COST CONC.	COST SEEDING	COST CUT/FILL	COST TOTAL
EA(T)-7	3	1500	20	8	1	0.00	57.50		120	0.00	86250	\$36,000.00	\$8,708.33	\$0.00	\$42,708.33
EA(T)-7	3	1500	10	6	1	0.00	47.50	46200	60	0.00	71250	\$18,000.00	\$5,541.67	\$184,800.00	\$208,341.67
* TOTAL COSTS =												\$54,000.00	\$12,250.00	\$184,800.00	\$364,420.00
DR1(T)-1	3	1400	20	7	0	0.00	63.75		0	0.00	89250	\$0.00	\$6,941.67	\$0.00	\$6,941.67
DR1(T)-1	3	2100	10	6	0	0.00	47.50	46200	0	0.00	99750	\$0.00	\$7,758.33	\$184,800.00	\$192,558.33
* TOTAL COSTS =												\$0.00	\$14,700.00	\$184,800.00	\$322,560.00
DR1(T)-2	3	2300	10	7	0	0.00	53.75	18500	0	0.00	123625	\$0.00	\$9,615.28	\$74,000.00	\$83,615.28
* TOTAL COSTS =												\$0.00	\$9,615.28	\$74,000.00	\$146,538.33
DR1(T)-3	3	1900	10	6	0	0.00	47.50	15300	0	0.00	90250	\$0.00	\$7,019.44	\$81,200.00	\$88,219.44
* TOTAL COSTS =												\$0.00	\$7,019.44	\$81,200.00	\$151,163.33
TOTAL WATERSHED COST															
TOTAL COSTS =												\$981,721.50	\$523,117.78	\$4,205,200.00	\$9,900,071.13

BREAKDOWN OF ROAD CROSSING COSTS

ROAD CROSSING	DESIGN SECTION	ROAD WIDTH (FEET)	BRIDGE LENGTH (FEET)	ROAD CROSSING COST
GUM SPRINGS	EA-5	30	50	\$57,750.00
E. COTTON ST	EA-6	36	124	\$171,570.00
TEXAS PAC. RR	EA-8			\$0.00
US HWY 60	EA-9	36	100	\$132,300.00
LEONA ST	EA-6	20	50	\$38,500.00
DOYLE ST	EA-6	20	50	\$38,500.00
US HWY 60	DR1-1	36	130	\$170,100.00
EDEN	DR1-3	36	50	\$89,300.00
ALPINE	DR1-3	36	50	\$89,300.00
LOOP 261	DR1-4	36	220	\$283,500.00
HOLLEYBROOK DR	DR1-4	36	50	\$89,300.00
TOTAL COSTS =				\$1,100,120.00
US HWY 250	EA(T)-1	20	115	\$84,000.00
LILLY	EA(T)-1	20	50	\$38,500.00
TOTAL COSTS =				\$122,500.00
SF RR	EA(T)-2			\$0.00
GUM SPRINGS RD	EA(T)-2	30	50	\$57,750.00
TOTAL COSTS =				\$57,750.00

TABLE C-3
CHANNEL QUANTITY AND COST CALCULATIONS
EASTMAN LAKE CREEK/ DRAIN NO. 1

BREAKDOWN OF ROAD CROSSING COSTS

ROAD CROSSING	DESIGN SECTION			ROAD CROSSING COST
OSBORN	EA(T)-3	36	50	\$69,300.00
UNKNOWN	EA(T)-3	36	50	\$69,300.00
US 259	EA(T)-3	36	120	\$157,500.00
LILLY	EA(T)-3	36	50	\$69,300.00
BIRDSONG	EA(T)-3	36	50	\$69,300.00
				TOTAL COSTS = \$434,700.00
US 259	EA(T)-4	36	115	\$151,200.00
LILLY	EA(T)-4	36	50	\$69,300.00
EL PASO	EA(T)-4	36	50	\$69,300.00
BEAUMONT	EA(T)-4	36	50	\$69,300.00
YOUNG	EA(T)-4	36	50	\$69,300.00
SAN ANTONIO	EA(T)-4	36	50	\$69,300.00
				TOTAL COSTS = \$497,700.00
US 259	EA(T)-6	22	115	\$92,400.00
TEXAS PAC RR	EA(T)-6			\$0.00
				TOTAL COSTS = \$92,400.00
FRJ DR	EA(T)-7	36	50	\$69,300.00
				TOTAL COSTS = \$69,300.00
PAGE	DR1(T)-1	36	50	\$69,300.00
				TOTAL COSTS = \$69,300.00
ALPINE	DR1(T)-2	20	50	\$38,500.00
				TOTAL COSTS = \$38,500.00
GARNER LN	DR1(T)-3	30	50	\$57,750.00
				TOTAL COSTS = \$57,750.00

* TOTAL COSTS OF EACH WATERSHED INCLUDES BRIDGE COSTS PLUS 20% CONTINGENCY AND ENGINEERING FEE

** EXCAVATIONS SUMMED FOR EACH STREAM REACH AT THE LAST SEGMENT IN THAT REACH

NOTES:

- 1) TYPE = CHANNEL MATERIAL, WHERE: 1-CONCRETE, 2-GRASS/CONCRETE, 3-GRASS, 4-NO IMPROVEMENT
- 2) CY/LF = CUBIC YARDS/LINEAR FOOT
- 3) SF/LF = SQUARE FEET/LINEAR FOOT

TABLE C-4
CHANNEL QUANTITY AND COST CALCULATIONS
ELM CREEK WATERSHED

WATERSHED	TYPE	LENGTH (FEET)	BOTTOM WIDTH (FEET)	DEPTH (FEET)	NUMBER DROPS	UNIT CONC. (CY/LF)	UNIT SEEDING (SF/LF)	EXCAVATION (CY)	DROP CONC. (CY)	CHANNEL CONC. (CY)	TOTAL SEEDING (SF)	COST CONC.	COST SEEDING	COST CUT/FILL	COST TOTAL
ELM CREEK															
EL-1	3	1300	30	7	0	0.00	73.75	890	0	0.00	95875	\$0.00	\$7,456.94	\$2,760.00	\$10,216.94
EL-1	1	1880	15	7	1	0.64	0.00	6770	48.75	1195.14	0	\$373,167.90	\$0.00	\$27,080.00	\$400,247.90
EL-1	3	2320	15	7	1	0.00	58.75	32880	90	0.00	136300	\$27,000.00	\$10,601.11	\$131,520.00	\$169,121.11
EL-1	3	800	10	5	0	0.00	41.25	3140	0	0.00	33000	\$0.00	\$2,566.67	\$12,560.00	\$15,126.67
* TOTAL COSTS =												\$400,167.90	\$20,624.72	\$173,920.00	\$778,025.15

TRIBUTARY INFORMATION

WATERSHED	TYPE	LENGTH (FEET)	BOTTOM WIDTH (FEET)	DEPTH (FEET)	NUMBER DROPS	UNIT CONC. (CY/LF)	UNIT SEEDING (SF/LF)	EXCAVATION (CY)	DROP CONC. (CY)	CHANNEL CONC. (CY)	TOTAL SEEDING (SF)	COST CONC.	COST SEEDING	COST CUT/FILL	COST TOTAL
EL(T)-1	3	800	15	3.4	0	0.00	36.25	824	0	0.00	29000	\$0.00	\$2,255.56	\$3,296.00	\$5,551.56
* TOTAL COSTS =												\$0.00	\$2,255.56	\$3,296.00	\$6,661.67

TOTAL WATERSHED COSTS

TOTAL COSTS = \$400,167.90 \$22,880.28 \$177,216.00 \$782,667.01

BREAKDOWN OF ROAD CROSSING COSTS

ROAD CROSSING	DESIGN SECTION	ROAD WIDTH (FEET)	BRIDGE LENGTH (FEET)	ROAD CROSSING COST
MILES ST	EL-1	33	72	\$88,935.00
RALPH ST	EL-1	33	29	\$39,270.00
IRVING ST	EL-1	33	29	\$39,270.00
SPUR 502	EL-1	66	57	\$163,680.00
PLIER PRECISE RD	EL-1	66	57	\$163,680.00
ST. CLAIR DR	EL-1	33	57	\$71,610.00
AMY ST	EL-1	33	40	\$51,975.00
TOTAL COSTS =				\$618,420.00

* TOTAL COSTS OF EACH WATERSHED INCLUDES BRIDGE COST PLUS 20% CONTINGENCY AND ENGINEERING FEE

NOTES:

- 1) TYPE = CHANNEL MATERIAL, WHERE: 1- CONCRETE, 2- GRASS/CONCRETE, 3- GRASS, 4- NO IMPROVEMENT
- 2) CY/LF = CUBIC YARDS/LINEAR FOOT
- 3) SF/LF = SQUARE FEET/LINEAR FOOT

TABLE C-5
CHANNEL QUANTITY AND COST CALCULATIONS
GILMER CREEK WATERSHED

WATERSHED	TYPE	LENGTH (FEET)	BOTTOM WIDTH (FEET)	DEPTH (FEET)	NUMBER DROPS	UNIT CONC. (CY/LF)	UNIT SEEDING (SF/LF)	EXCAVATION (CY)	DROP CONC. (CY)	CHANNEL CONC. (CY)	TOTAL SEEDING (SF)	COST CONC.	COST SEEDING	COST CUT/FILL	COST TOTAL
GILMER CREEK															
GI-1	3	396	60	5.50	0	0.00	94.38	7550	0	0.00	37373	\$0.00	\$2,908.75	\$30,200.00	\$33,108.75
GI-1	2	2640	40	4.50	0	0.66	14.23	48450	0	2269.87	37568	\$680,981.80	\$2,921.84	\$186,800.00	\$869,883.54
GI-2	2	725	40	4.00	0	0.85	12.65	5200	0	813.93	9171	\$184,179.00	\$713.27	\$20,800.00	\$205,692.27
GI-2	4	665	0	0.00	0	0.00	0.00	0	0	0.00	0	\$0.00	\$0.00	\$0.00	\$0.00
GI-2	4	2000	0	0.00	0	0.00	0.00	0	0	0.00	0	\$0.00	\$0.00	\$0.00	\$0.00
GI-2	3	1605	40	5.70	0	0.00	75.62	10780	0	0.00	121378	\$0.00	\$9,440.52	\$43,040.00	\$52,480.52
GI-3	3	1200	10	5.80	2	0.00	46.25	1628	120	0.00	55500	\$38,000.00	\$4,318.67	\$8,504.00	\$48,822.67
* TOTAL COSTS=												\$901,140.80	\$20,299.15	\$288,344.00	\$2,365,862.70

TRIBUTARY INFORMATION

WATERSHED	TYPE	LENGTH (FEET)	BOTTOM WIDTH (FEET)	DEPTH (FEET)	NUMBER DROPS	UNIT CONC. (CY/LF)	UNIT SEEDING (SF/LF)	EXCAVATION (CY)	DROP CONC. (CY)	CHANNEL CONC. (CY)	TOTAL SEEDING (SF)	COST CONC.	COST SEEDING	COST CUT/FILL	COST TOTAL
GI(T)-1	3	240	30	5.65	0	0.00	65.31	462	0	0.00	15675	\$0.00	\$1,219.17	\$1,848.00	\$3,087.17
	3	575	30	4.7	0	0.00	59.38	1107	0	0.00	34141	\$0.00	\$2,655.38	\$4,428.00	\$7,083.38
	3	1385	30	4.87	0	0.00	59.19	2940	0	0.00	81975	\$0.00	\$6,375.81	\$11,796.00	\$18,171.81
	3	1000	30	4.51	3	0.00	58.19	497	540	0.00	58188	\$102,000.00	\$4,525.69	\$1,988.00	\$108,513.69
	2	2680	5	5.94	5	0.25	18.78	2109	67.5	657.79	49685	\$223,567.42	\$3,888.19	\$8,438.00	\$235,908.61
* TOTAL COSTS=												\$365,587.42	\$18,682.24	\$28,496.00	\$1,188,038.78

TOTAL WATERSHED COSTS

TOTAL COSTS= \$1,288,728.02 \$38,981.39 \$314,840.00 \$3,583,701.49

BREAKDOWN OF ROAD CROSSING COSTS

ROAD CROSSING	DESIGN SECTION	ROAD WIDTH (FEET)	BRIDGE LENGTH (FEET)	ROAD CROSSING COSTS
BILL OWENS PWKY	GI-1	66	93	\$258,984.00
STONEWALL ST	GI-1	33	56	\$72,680.50
H.G. MOSELY BLVD	GI-2	66	51	\$147,840.00
SECLUDED LN/MEANDERING LN	GI-2	33	74	\$91,478.00
LOOP 281	GI-3	66	74	\$209,088.00
TOTAL COSTS=				\$780,268.50
GILMER	GI(T)-1	66	56	\$168,320.00
H.G. MOSELEY BLVD	GI(T)-1	66	57	\$163,680.00
ROSEDOWN	GI(T)-1	33	29	\$39,270.00
WHISPERING PINES	GI(T)-1	33	29	\$39,270.00
FERNDALE	GI(T)-1	33	29	\$39,270.00
WILLOWVIEW	GI(T)-1	33	29	\$39,270.00
SPRINGDALE	GI(T)-1	33	29	\$39,270.00
PINERIDGE	GI(T)-1	33	29	\$39,270.00
TOTAL COSTS=				\$565,820.00

* TOTAL COSTS OF EACH WATERSHED INCLUDES BRIDGE COST PLUS 20% CONTINGENCY AND ENGINEERING FEE

NOTES:

- 1) TYPE = CHANNEL MATERIAL, WHERE: 1-CONCRETE, 2-GRASS/CONCRETE, 3-GRASS, 4-NO IMPROVEMENT
- 2) CY/LF = CUBIC YARDS/LINEAR FOOT
- 3) SF/LF = SQUARE FEET/LINEAR FOOT

TABLE C-6
CHANNEL QUANTITY AND COST CALCULATIONS
GRACE CREEK WATERSHED

WATERSHED	TYPE	LENGTH (FEET)	BOTTOM WIDTH (FEET)	DEPTH (FEET)	NUMBER DROPS	UNIT CONC. (CY/LF)	UNIT SEEDING (SF/LF)	EXCAVATION (CY)	DROP CONC. (CY)	CHANNEL CONC. (CY)	TOTAL SEEDING (SF)	COST CONC.	COST SEEDING	COST CUT/FILL	COST TOTAL
GRACE CREEK															
GR-1,2,3	2	7035	75	12.00	0	1.70	37.95	358000	0	11992.92	269959	\$3,597,874.88	\$20,763.52	\$1,432,000.00	\$5,050,638.39
GR-4	2	4500	75	12.00	0	1.70	37.95	164000	0	7871.38	170763	\$2,301,412.50	\$13,281.57	\$658,000.00	\$2,970,694.07
GR-4	2	2310	75	15.00	1	1.78	47.43	99000	262.5	4118.15	109573	\$1,314,195.75	\$8,522.34	\$396,000.00	\$1,718,718.09
GR-4	2	900	75	10.00	0	1.85	31.62	42000	0	1487.48	28480	\$448,242.50	\$2,213.59	\$168,000.00	\$616,458.09
GR-5	2	2750	65	8.00	0	1.42	25.30	320000	0	3681.39	69570	\$1,167,416.25	\$5,411.01	\$1,280,000.00	\$2,452,827.26
GR-5	2	1550	65	8.00	0	1.42	25.30	57000	0	2193.33	39212	\$657,998.25	\$3,049.84	\$226,000.00	\$889,048.09
GR-6	2	1125	65	8.00	0	1.42	25.30	82000	0	1591.93	28480	\$477,579.38	\$2,213.59	\$328,000.00	\$807,792.97
GR-6	2	1850	65	10.00	0	1.47	31.62	112000	0	2420.63	52178	\$726,189.75	\$4,056.26	\$448,000.00	\$1,178,248.01
GR-6	2	1910	60	10.00	0	1.37	31.62	81000	0	2624.72	60400	\$787,416.80	\$4,697.74	\$244,000.00	\$1,036,114.34
GR-7	2	1475	60	12.00	0	1.43	37.95	73000	0	2103.65	55972	\$631,093.50	\$4,353.40	\$292,000.00	\$927,446.90
GR-8	2	2425	55	10.00	0	1.26	31.62	43000	0	3107.27	78885	\$932,182.13	\$5,984.41	\$172,000.00	\$1,110,146.53
GR-8,GR-9	2	2560	55	8.00	0	1.23	25.30	14000	0	3147.14	64783	\$944,140.80	\$5,037.18	\$56,000.00	\$1,005,177.98
GR-10	2	1500	55	8.00	0	1.23	25.30	68000	0	1844.03	37947	\$553,207.50	\$2,951.48	\$272,000.00	\$828,158.98
GR-11,12A,12B	4	2500	0	0.00	0	0.00	0.00	68000	0	0.00	0	\$0.00	\$0.00	\$0.00	\$0.00
GR-12B	3	3800	100	5.00	0	0.00	131.25	34000	0	0.00	498750	\$0.00	\$36,791.87	\$138,000.00	\$174,791.87
GR-12B	3	3175	100	6.00	0	0.00	137.50	28000	0	0.00	438583	\$0.00	\$33,954.88	\$112,000.00	\$145,954.88
GR-12B	3	3875	100	7.00	0	0.00	143.75	35000	0	0.00	557031	\$0.00	\$43,324.85	\$140,000.00	\$183,324.85
GR-12B	3	3050	100	5.00	0	0.00	131.25	49000	0	0.00	400313	\$0.00	\$31,135.42	\$198,000.00	\$227,135.42
GR-13	3	2500	60	5.00	0	0.00	91.25	10000	0	0.00	228125	\$0.00	\$17,743.06	\$40,000.00	\$57,743.06
GR-14	3	3370	50	7.00	0	0.00	93.75	18000	0	0.00	315838	\$0.00	\$24,572.92	\$64,000.00	\$88,572.92
GR-15	3	1850	40	6.00	0	0.00	77.50	14000	0	0.00	127875	\$0.00	\$9,945.83	\$56,000.00	\$65,945.83
GR-16	3	2050	30	6.00	0	0.00	67.50	10000	0	0.00	136375	\$0.00	\$10,762.50	\$40,000.00	\$50,762.50
GR-16	3	3700	20	6.00	0	0.00	57.50	6000	0	0.00	212750	\$0.00	\$16,547.22	\$24,000.00	\$40,547.22
* TOTAL COSTS =												\$14,538,949.78	\$309,298.00	\$6,780,000.00	\$20,219,288.83

TRIBUTARY INFORMATION

WATERSHED	TYPE	LENGTH (FEET)	BOTTOM WIDTH (FEET)	DEPTH (FEET)	NUMBER DROPS	UNIT CONC. (CY/LF)	UNIT SEEDING (SF/LF)	EXCAVATION (CY)	DROP CONC. (CY)	CHANNEL CONC. (CY)	TOTAL SEEDING (SF)	COST CONC.	COST SEEDING	COST CUT/FILL	COST TOTAL
GR(T)-1	3	520	50	3.00	1	0.00	66.75	539	300	0.00	35750	\$80,000.00	\$2,780.56	\$2,158.00	\$84,938.56
	3	940	50	3.20	0	0.00	70.00	975	0	0.00	65800	\$0.00	\$5,117.78	\$3,900.00	\$9,017.78
	3	640	45	3.50	0	0.00	66.88	908	0	0.00	42800	\$0.00	\$3,326.69	\$3,832.00	\$6,988.69
	3	800	15	3.80	0	0.00	38.75	311	0	0.00	23250	\$0.00	\$1,606.33	\$1,244.00	\$3,052.33
	3	520	15	3.60	0	0.00	37.50	1230	0	0.00	19500	\$0.00	\$1,518.67	\$4,920.00	\$6,438.67
	3	280	15	3.30	1	0.00	35.62	1100	90	0.00	9975	\$27,000.00	\$775.83	\$4,400.00	\$32,175.83
* TOTAL COSTS =												\$117,000.00	\$15,326.06	\$20,252.00	\$47,528.07
GR(T)-2	3	2400	30	5.01	0	0.00	61.31	6895	0	0.00	147150	\$0.00	\$11,445.00	\$35,580.00	\$47,025.00
	3	760	30	4.30	0	0.00	56.88	1089	0	0.00	43225	\$0.00	\$3,381.94	\$4,358.00	\$7,717.94
	3	1440	30	4.20	0	0.00	56.25	680	0	0.00	81000	\$0.00	\$6,300.00	\$2,640.00	\$8,940.00
	3	1170	30	4.00	0	0.00	55.00	128	0	0.00	64350	\$0.00	\$5,005.00	\$504.00	\$5,509.00
* TOTAL COSTS =												\$0.00	\$26,111.94	\$43,080.00	\$257,668.33

TABLE C-6
CHANNEL QUANTITY AND COST CALCULATIONS
GRACE CREEK WATERSHED

WATERSHED	TYPE	LENGTH (FEET)	BOTTOM WIDTH (FEET)	DEPTH (FEET)	NUMBER DROPS	UNIT CONC. (CY/LF)	UNIT SEEDING (SF/LF)	EXCAVATION (CY)	DROP CONC. (CY)	CHANNEL CONC. (CY)	TOTAL SEEDING (SF)	COST CONC.	COST SEEDING	COST CUT/FILL	COST TOTAL
GR(T)-2A	3	500	10	3.66	0	0.00	32.88	574	0	0.00	16438	\$0.00	\$1,276.47	\$2,296.00	\$3,574.47
	3	410	10	3.66	1	0.00	32.88	471	60	0.00	13479	\$18,000.00	\$1,048.35	\$1,664.00	\$20,932.35
	3	290	5	3.39	2	0.00	26.19	333	60	0.00	7594	\$18,000.00	\$590.67	\$1,332.00	\$19,922.67
	3	1000	5	3.91	0	0.00	29.44	1148	0	0.00	29438	\$0.00	\$2,289.58	\$4,592.00	\$6,881.58
* TOTAL COSTS =												\$36,000.00	\$5,207.08	\$10,104.00	\$320,953.29
GR(T)-3	3	760	15	4.00	0	0.00	40.00	1717	0	0.00	30400	\$0.00	\$2,364.44	\$6,866.00	\$9,232.44
	3	840	15	3.60	0	0.00	37.50	2124	0	0.00	35250	\$0.00	\$2,741.67	\$6,496.00	\$11,237.67
* TOTAL COSTS =												\$0.00	\$5,106.11	\$13,364.00	\$157,620.13
GR(T)-4	3	70	30	3.10	0	0.00	49.38	127	0	0.00	3456	\$0.00	\$266.62	\$506.00	\$776.62
	3	330	30	2.90	0	0.00	48.13	596	0	0.00	15881	\$0.00	\$1,235.21	\$2,392.00	\$3,627.21
	3	620	20	3.70	1	0.00	43.13	563	120	0.00	26736	\$36,000.00	\$2,079.58	\$2,252.00	\$40,331.58
* TOTAL COSTS =												\$36,000.00	\$3,563.61	\$5,152.00	\$53,682.73
GR(T)-5	3	230	25	3.50	1	0.00	46.68	323	150	0.00	10761	\$45,000.00	\$638.54	\$1,292.00	\$47,130.54
	3	1500	20	4.00	0	0.00	45.00	1772	0	0.00	67500	\$0.00	\$5,250.00	\$7,066.00	\$12,336.00
	1	1170	20	4.50	3	0.61	0.00	617	195	706.32	0	\$270,995.40	\$0.00	\$2,466.00	\$273,463.40
	3	540	15	4.50	1	0.00	43.13	320	90	0.00	23266	\$27,000.00	\$1,811.25	\$1,280.00	\$30,091.25
* TOTAL COSTS =												\$342,995.40	\$7,699.79	\$12,126.00	\$739,755.63
GR(T)-6	2	300	45	3.60	0	0.93	11.36	1226	0	276.76	3415	\$63,632.50	\$265.63	\$4,904.00	\$68,602.13
	3	480	40	3.90	0	0.00	64.36	1955	0	0.00	30900	\$0.00	\$2,403.33	\$7,620.00	\$10,223.33
	3	1440	25	5.00	0	0.00	56.25	4526	0	0.00	81000	\$0.00	\$6,300.00	\$16,112.00	\$24,412.00
	3	580	25	3.60	1	0.00	47.50	841	150	0.00	27550	\$45,000.00	\$2,142.76	\$3,364.00	\$50,506.76
	3	680	25	3.65	0	0.00	47.81	685	0	0.00	31556	\$0.00	\$2,454.37	\$2,740.00	\$5,194.37
* TOTAL COSTS =												\$126,632.50	\$13,566.12	\$36,940.00	\$379,702.34
GR(T)-7	3	920	15	3.06	0	0.00	34.12	0	0	0.00	31395	\$0.00	\$2,441.63	\$0.00	\$2,441.63
	3	580	15	3.55	0	0.00	37.19	77	0	0.00	21566	\$0.00	\$1,677.57	\$306.00	\$1,965.57
	3	240	5	4.16	1	0.00	31.00	55	30	0.00	7440	\$9,000.00	\$576.67	\$220.00	\$9,796.67
	3	500	5	4.54	0	0.00	33.36	165	0	0.00	16666	\$0.00	\$1,297.92	\$740.00	\$2,037.92
	3	290	5	4.45	0	0.00	32.81	71	0	0.00	9516	\$0.00	\$740.10	\$264.00	\$1,024.10
* TOTAL COSTS =												\$9,000.00	\$6,736.09	\$1,552.00	\$20,745.71
GR(T)-8	3	630	10	5.30	0	0.00	43.13	6240	0	0.00	35794	\$0.00	\$2,763.96	\$24,960.00	\$27,743.96
	3	2120	10	5.66	0	0.00	45.36	6166	0	0.00	96195	\$0.00	\$7,481.63	\$24,672.00	\$32,153.63
	3	270	10	5.03	1	0.00	41.44	1271	60	0.00	11166	\$16,000.00	\$670.19	\$5,064.00	\$23,654.19
* TOTAL COSTS =												\$16,000.00	\$11,135.68	\$54,716.00	\$168,536.36

C-10

TABLE C-8
CHANNEL QUANTITY AND COST CALCULATIONS
GRACE CREEK WATERSHED

WATERSHED	TYPE	LENGTH (FEET)	BOTTOM WIDTH (FEET)	DEPTH (FEET)	NUMBER DROPS	UNIT CONC. (CY/LF)	UNIT SEEDING (SF/LF)	EXCAVATION (CY)	DROP CONC. (CY)	CHANNEL CONC. (CY)	TOTAL SEEDING (SF)	COST CONC.	COST SEEDING	COST CUT/FILL	COST TOTAL
GR(T)-9	3	300	30	3.90	0	0.00	54.38	187	0	0.00	16313	\$0.00	\$1,268.75	\$668.00	\$1,936.75
	3	660	15	4.22	0	0.00	41.38	366	0	0.00	27306	\$0.00	\$2,123.92	\$1,464.00	\$3,587.92
* TOTAL COSTS =												\$0.00	\$3,392.67	\$2,132.00	\$6,629.60

TOTAL WATERSHED COSTS

TOTAL COSTS = \$15,224,577.68 \$407,363.45 \$8,961,420.00 \$31,742,107.35

BREAKDOWN OF ROAD CROSSING COST

ROAD CROSSING	DESIGN SECTION	ROAD WIDTH (FEET)	BRIDGE LENGTH (FEET)	ROAD CROSSING COST
FM 1845	GR-1	66	123	\$337,920.00
MISSOURI PAC RR	GR-3			\$0.00
SABINE ST.	GR-3	NI	NI	\$0.00
HWY 31	GR-3	66	135	\$369,600.00
COTTON ST	GR-3	66	135	\$369,600.00
TX. PAC. RR	GR-4			\$0.00
US HWY 60	GR-5	66	97	\$299,280.00
FAIRMONT	GR-6	66	105	\$290,400.00
H.G. MOSELY	GR-8	66	95	\$264,000.00
LOOP 281	GR-10,11	NI	NI	\$0.00
SPRING HILL	GR-12B	66	136	\$372,240.00
GRAY STONE	GR-14	66	92	\$256,080.00
UNKNOWN	GR-14	33	92	\$112,035.00
WINDING WAY	GR-16	33	66	\$82,005.00
TOTAL COSTS =				\$2,723,160.00
BIRDSONG ST	GR(T)-1	66	69	\$195,360.00
INTERNATIONAL RR	GR(T)-1			\$0.00
TOTAL COSTS =				\$195,360.00
DELLA	GR(T)-2	33	60	\$75,075.00
RAY ST	GR(T)-2	33	56	\$70,455.00
MOPAC RR	GR(T)-2			\$0.00
TOTAL COSTS =				\$145,530.00
SPUR 63	GR(T)-2A	66	32	\$97,680.00
COTTON STREET	GR(T)-2A	66	25	\$79,200.00
GRIGSBY	GR(T)-2A	33	29	\$39,270.00
TOTAL COSTS =				\$216,150.00
BILL OWENS PWKY	GR(T)-3	66	37	\$110,880.00
TOTAL COSTS =				\$110,880.00

TABLE C-8
CHANNEL QUANTITY AND COST CALCULATIONS
GRACE CREEK WATERSHED

BREAKDOWN OF ROAD CROSSING COST

ROAD CROSSING	DESIGN SECTION	ROAD WIDTH (FEET)	BRIDGE LENGTH (FEET)	ROAD CROSSING COST
BILL OWENS PWKY LOOP 281	GR(T)-5	66	44	\$129,360.00
	GR(T)-5	66	42	\$124,080.00
				TOTAL COSTS = \$253,440.00
MCCANN RD	GR(T)-6	66	47	\$137,280.00
				TOTAL COSTS = \$137,280.00
WINDING WAY	GR(T)-8	33	44	\$56,595.00
				TOTAL COSTS = \$56,595.00

* TOTAL COSTS OF EACH WATERSHED INCLUDES BRIDGE COST PLUS 20% CONTINGENCY AND ENGINEERING FEE

NOTES:

- 1) TYPE = CHANNEL MATERIAL, WHERE: 1-CONCRETE, 2-GRASS/CONCRETE, 3-GRASS, 4-NO IMPROVEMENT
- 2) CY/LF = CUBIC YARDS/LINEAR FOOT
- 3) SF/LF = SQUARE FEET/LINEAR FOOT
- 4) NI = NO IMPROVEMENT

TABLE C-7
CHANNEL QUANTITY AND COST CALCULATIONS
GUTHRIE WATERSHED

WATERSHED	TYPE	LENGTH (FEET)	BOTTOM WIDTH (FEET)	DEPTH (FEET)	NUMBER DROPS	UNIT CONC. (CY/LF)	UNIT SEEDING (SF/LF)	EXCAVATION (CY)	DROP CONC. (CY)	CHANNEL CONC. (CY)	TOTAL SEEDING (SF)	COST CONC.	COST SEEDING	COST CUT/FILL	COST TOTAL
GUTHRIE CREEK															
GU-1	4	0	0.00	0	0	0.00	0.00	0	0	0.00	0	\$0.00	\$0.00	\$0.00	\$0.00
GU-1	2	1410	70.00	11.2	1	1.59	35.42	26200	245	2243.45	49939	\$746,535.30	\$3,884.12	\$104,800.00	\$855,219.42
GU-2	2	1220	70.00	10.8	1	1.58	34.15	11400	245	1928.45	41666	\$652,036.20	\$3,240.70	\$45,600.00	\$700,876.90
GU-2	2	2480	70.00	10.2	0	1.57	32.28	9500	0	3881.45	79993	\$1,164,434.40	\$6,221.68	\$38,000.00	\$1,208,656.08
GU-3	2	875	65.00	10.7	1	1.49	33.84	24400	227.5	1002.54	22840	\$369,013.13	\$1,776.41	\$97,800.00	\$468,389.53
GU-4	2	590	80.00	9.4	0	1.38	29.73	2800	0	801.57	17536	\$240,472.20	\$1,364.07	\$10,400.00	\$252,236.27
GU-5	3	310	40.00	8.1	0	0.00	90.83	1700	0	0.00	28094	\$0.00	\$2,165.07	\$6,800.00	\$8,965.07
GU-5	3	1325	15.00	9	2	0.00	71.25	33100	180	0.00	94406	\$54,000.00	\$7,342.71	\$132,400.00	\$193,742.71
GU-5,8	3	930	10.00	8.9	1	0.00	65.83	8200	60	0.00	61031	\$16,000.00	\$4,746.87	\$32,800.00	\$55,546.88
GU-6	3	235	10.00	7.3	0	0.00	55.83	900	0	0.00	13072	\$0.00	\$1,016.70	\$3,600.00	\$4,616.70
GU-6	1	1940	15.00	4	1	0.49	0.00	5028	48.75	943.91	0	\$297,797.10	\$0.00	\$20,112.00	\$317,909.10
GU-6	2	1760	15.00	4.6	3	0.40	14.55	3469	157.5	700.74	25602	\$257,473.20	\$1,991.25	\$13,876.00	\$273,340.45
GU-6	2	1280	15.00	3.1	1	0.38	9.80	1589	52.5	459.71	12548	\$153,663.60	\$975.95	\$8,276.00	\$160,915.55
* TOTAL COSTS =												\$3,953,425.13	\$34,745.53	\$512,264.00	\$7,074,611.56

TRIBUTARY INFORMATION

C-13

WATERSHED	TYPE	LENGTH (FEET)	BOTTOM WIDTH (FEET)	DEPTH (FEET)	NUMBER DROPS	UNIT CONC. (CY/LF)	UNIT SEEDING (SF/LF)	EXCAVATION (CY)	DROP CONC. (CY)	CHANNEL CONC. (CY)	TOTAL SEEDING (SF)	COST CONC.	COST SEEDING	COST CUT/FILL	COST TOTAL
GU(T)-1	2	240	10.00	4.17	1	0.29	13.19	205	35	70.59	3185	\$31,876.64	\$246.15	\$820.00	\$32,742.79
	2	800	10.00	4.17	2	0.29	13.19	506	70	176.47	7912	\$73,941.60	\$615.36	\$2,024.00	\$76,580.96
	2	960	10.00	4.17	2	0.29	13.19	1014	70	282.36	12659	\$105,706.56	\$964.61	\$4,056.00	\$110,747.17
	3	1325	5.00	3.73	0	0.00	28.31	666	0	0.00	37514	\$0.00	\$2,917.78	\$2,744.00	\$5,661.76
	3	893	5.00	3.28	1	0.00	25.50	103	30	0.00	17672	\$9,000.00	\$1,374.45	\$412.00	\$10,786.45
* TOTAL COSTS =												\$220,324.80	\$6,136.35	\$10,056.00	\$641,676.96
GU(T)-2	3	790	10.00	4	2	0.00	35.00	527	120	0.00	27650	\$36,000.00	\$2,150.56	\$2,106.00	\$40,256.56
* TOTAL COSTS =												\$36,000.00	\$2,150.56	\$2,106.00	\$46,310.27
GU(T)-3	3	1160	15.00	2.54	0	0.00	30.88	816	0	0.00	35815	\$0.00	\$2,786.61	\$3,264.00	\$6,049.61
	3	750	10.00	3.49	0	0.00	31.81	526	0	0.00	23859	\$0.00	\$1,855.73	\$2,112.00	\$3,967.73
	3	475	10.00	3.33	0	0.00	30.81	345	0	0.00	14636	\$0.00	\$1,136.35	\$1,380.00	\$2,516.35
* TOTAL COSTS =												\$0.00	\$5,779.69	\$6,756.00	\$272,838.63

TOTAL WATERSHED COSTS

TOTAL COSTS = \$4,209,749.93 \$46,814.12 \$531,164.00 \$6,237,439.66

TABLE C-7
CHANNEL QUANTITY AND COST CALCULATIONS
GUTHRIE WATERSHED

BREAKDOWN OF ROAD CROSSING COST

ROAD CROSSING	DESIGN SECTION	ROAD WIDTH (FEET)	BRIDGE LENGTH (FEET)	ROAD CROSSING COST
SPUR 83	GU-1	66	115	\$316,800.00
GLENCREST LN	GU-2	33	110	\$132,825.00
MEADOWBROOK	GU-2	33	110	\$132,825.00
JOHNSON	GU-2	33	111	\$133,980.00
JUDSON	GU-2	66	111	\$306,240.00
N FOURTH ST	GU-5	66	63	\$179,520.00
WOOD PL	GU-6	33	54	\$68,145.00
TENTH ST	GU-6	33	33	\$43,890.00
PEGUES	GU-6	33	33	\$43,890.00
HUGHY DR	GU-6	33	27	\$36,960.00
MAHLOW	GU-6	33	27	\$36,960.00
				TOTAL COSTS= \$1,395,075.00
TUPELO DR	GU(T)-1	33	27	\$36,960.00
OXFORD LN		33	27	\$36,960.00
HIGH ST		66	27	\$84,480.00
JUDSON		66	27	\$84,480.00
N CENTER ST		66	25	\$79,200.00
FREDONIA ST		53	25	\$83,600.00
N GREEN ST		66	25	\$79,200.00
				TOTAL COSTS= \$484,880.00
N. FOURTH ST	GU(T)-3	66	30	\$92,400.00
GARDENIA		33	30	\$40,425.00
LE DUKE		33	30	\$40,425.00
TENTH ST		33	31	\$41,580.00
				TOTAL COSTS= \$214,830.00

* TOTAL COST OF EACH WATERSHED INCLUDES BRIDGE COST PLUS 20% CONTINGENCY AND ENGINEERING FEE

NOTES:

- 1) TYPE = CHANNEL MATERIAL, WHERE: 1- CONCRETE, 2- GRASS/CONCRETE, 3- GRASS, 4- NO IMPROVEMENT
- 2) CY/LF = CUBIC YARDS/LINEAR FOOT
- 3) SF/LF = SQUARE FEET/LINEAR FOOT

TABLE C-8
CHANNEL QUANTITY AND COST CALCULATIONS
HARRIS CREEK/DRAIN NO. 4 WATERSHED

WATERSHED	TYPE	LENGTH (FEET)	BOTTOM WIDTH (FEET)	DEPTH (FEET)	NUMBER DROPS	UNIT CONC. (CY/LF)	UNIT SEEDING (SF/LF)	EXCAVATION (CY)	DROP CONC. (CY)	CHANNEL CONC. (CY)	TOTAL SEEDING (SF)	COST CONC.	COST SEEDING	COST CUT/FILL	COST TOTAL
HARRIS CREEK															
HA-1	1	3290	75.00	6	4	1.70	0.00	71985	975	5608.63	0	\$1,975,088.25	\$0.00	\$267,940.00	\$2,263,028.25
HA-1	1	2730	75.00	7.5	0	1.78	0.00	13000	0	4868.91	0	\$1,460,072.25	\$0.00	\$52,000.00	\$1,512,072.25
HA-1	1	1385	75.00	7.5	0	1.78	0.00	7300	0	2469.11	0	\$740,732.63	\$0.00	\$29,200.00	\$769,932.63
HA-1	2	415	75.00	7.3	0	1.58	23.08	5800	0	858.78	9580	\$197,027.48	\$745.12	\$23,200.00	\$220,972.60
HA-2	2	1170	75.00	6.7	0	1.57	21.19	15500	0	1833.33	24769	\$549,999.45	\$1,926.04	\$62,000.00	\$613,927.49
HA-2	2	1250	70.00	6.9	1	1.48	21.82	24500	245	1849.13	27275	\$628,237.50	\$2,121.36	\$98,000.00	\$728,358.86
HA-2	2	980	60.00	7.5	1	1.31	23.72	15000	210	1258.83	22768	\$440,049.60	\$1,770.66	\$60,000.00	\$501,820.48
HA-2	2	475	65.00	7.8	0	1.40	24.03	8000	0	667.21	11416	\$200,162.63	\$867.97	\$24,000.00	\$225,050.52
HA-2	2	240	40.00	7.85	1	0.95	24.82	2900	140	227.26	5958	\$110,176.80	\$463.38	\$11,600.00	\$122,240.18
HA-2,3	2	525	45.00	7.9	1	1.04	24.98	3500	157.5	546.56	13116	\$211,215.38	\$1,020.10	\$14,000.00	\$226,235.47
HA-3	2	1475	40.00	6.6	1	0.92	21.50	4800	140	1358.41	31719	\$448,923.00	\$2,466.93	\$19,200.00	\$470,589.93
HA-4	2	1100	35.00	6.6	1	0.82	20.87	900	122.5	903.71	22958	\$307,861.50	\$1,785.83	\$3,600.00	\$313,247.13
HA-5	2	1400	30.00	5.3	1	0.89	16.78	10700	105	972.86	23464	\$323,358.00	\$1,624.99	\$42,800.00	\$367,982.99
HA-5	3	2000	25.00	7	1	0.00	66.75	9300	150	0.00	137500	\$45,000.00	\$10,694.44	\$37,200.00	\$92,894.44
HA-5	3	1225	25.00	6.4	0	0.00	65.00	3600	0	0.00	79825	\$0.00	\$6,193.06	\$14,400.00	\$20,593.06
HA-5	3	1325	25.00	5.8	0	0.00	60.00	4900	0	0.00	79500	\$0.00	\$6,183.33	\$19,600.00	\$25,783.33
HA-5	3	945	20.00	5.4	1	0.00	53.75	5600	120	0.00	50794	\$36,000.00	\$3,950.62	\$22,400.00	\$62,350.63
HA-5	3	190	15.00	4.8	0	0.00	45.00	1400	0	0.00	8550	\$0.00	\$665.00	\$5,800.00	\$6,265.00
HA-5	3	600	20.00	4.2	1	0.00	46.25	1750	120	0.00	27750	\$36,000.00	\$2,158.33	\$7,000.00	\$45,158.33
HA-5	3	600	10.00	5.5	1	0.00	44.36	1750	60	0.00	26625	\$16,000.00	\$2,070.83	\$7,000.00	\$27,070.83
* TOTAL COSTS =												\$7,727,904.45	\$46,929.94	\$840,740.00	\$12,658,754.27
DRAIN NO. 4															
DR4-1	2	703	50	3.4	1	1.02	10.75	9100	175	714.66	7558	\$266,964.21	\$587.88	\$36,400.00	\$303,952.09
DR4-1	2	330	40	4.7	0	0.87	14.66	1500	0	285.45	4905	\$65,835.00	\$361.46	\$6,000.00	\$92,016.46
DR4-1	2	547	40	3.5	0	0.83	11.07	2400	0	456.09	6054	\$136,626.58	\$470.88	\$9,600.00	\$146,697.46
DR4-1	2	1770	30	3.4	0	0.65	10.75	7800	0	1142.54	19031	\$342,760.50	\$1,480.16	\$31,200.00	\$375,440.66
DR4-1	2	820	12	5.3	0	0.36	16.78	4600	0	295.72	13743	\$66,717.44	\$1,066.92	\$16,400.00	\$108,186.36
DR4-1	2	320	12	4.6	1	0.34	14.55	1900	42	109.58	4655	\$45,474.24	\$362.05	\$7,600.00	\$53,436.29
DR4-1	4	619	0	0.0	0	0.00	0.00	0	0	0.00	0	\$0.00	\$0.00	\$0.00	\$0.00
DR4-1	2	292	15	5.0	0	0.41	15.81	2400	0	119.30	4617	\$35,788.98	\$359.09	\$9,600.00	\$45,748.07
DR4-1	3	962	15	3.9	0	0.00	39.19	1354	0	0.00	37698	\$0.00	\$2,932.10	\$5,416.00	\$8,348.10
* TOTAL COSTS =												\$1,002,166.66	\$7,642.55	\$124,216.00	\$2,108,012.60
TRIBUTARY INFORMATION															
WATERSHED	TYPE	LENGTH (FEET)	BOTTOM WIDTH (FEET)	DEPTH (FEET)	NUMBER DROPS	UNIT CONC. (CY/LF)	UNIT SEEDING (SF/LF)	EXCAVATION (CY)	DROP CONC. (CY)	CHANNEL CONC. (CY)	TOTAL SEEDING (SF)	COST CONC.	COST SEEDING	COST CUT/FILL	COST TOTAL
HA(T)-1	3	560	35.00	3.77	0	0.00	56.56	1245	0	0.00	32765	\$0.00	\$2,550.72	\$4,960.00	\$7,530.72
	3	1940	35.00	3.67	3	0.00	57.94	4551	630	0.00	112399	\$169,000.00	\$6,742.12	\$18,204.00	\$215,946.13
* TOTAL COSTS =												\$169,000.00	\$11,292.85	\$23,164.00	\$354,797.22

**TABLE C-6
CHANNEL QUANTITY AND COST CALCULATIONS
HARRIS CREEK/DRAIN NO. 4 WATERSHED**

WATERSHED	TYPE	LENGTH (FEET)	BOTTOM WIDTH (FEET)	DEPTH (FEET)	NUMBER DROPS	UNIT CONC. (CY/LF)	UNIT SEEDING (SF/LF)	EXCAVATION (CY)	DROP CONC. (CY)	CHANNEL CONC. (CY)	TOTAL SEEDING (SF)	COST CONC.	COST SEEDING	COST CUT/FILL	COST TOTAL
HA(T)-2	2	500	30.00	3.91	0	0.88	12.38	778	0	329.38	8182	\$98,814.00	\$480.84	\$3,112.00	\$102,406.84
	3	480	25.00	4.21	0	0.00	51.31	1021	0	0.00	24630	\$0.00	\$1,915.67	\$4,084.00	\$5,999.67
	2	720	15.00	5.1	2	0.41	18.13	1992	105	298.03	11612	\$120,308.40	\$903.15	\$7,988.00	\$129,179.55
* TOTAL COSTS =												\$219,122.40	\$3,299.66	\$15,164.00	\$362,026.27
HA(T)-3	1	240	25.00	4.88	0	0.71	0.00	338	0	189.83	0	\$50,947.92	\$0.00	\$1,352.00	\$52,299.92
	3	1080	25.00	4.31	0	0.00	51.94	1485	0	0.00	55054	\$0.00	\$4,281.98	\$5,600.00	\$10,141.98
	3	820	25.00	4.44	0	0.00	52.75	758	0	0.00	32705	\$0.00	\$2,543.72	\$3,024.00	\$5,567.72
	3	440	20.00	4.57	0	0.00	48.58	537	0	0.00	21388	\$0.00	\$1,861.92	\$2,148.00	\$3,809.92
* TOTAL COSTS =												\$50,947.92	\$8,487.80	\$12,384.00	\$158,948.42
TOTAL WATERSHED COSTS															
TOTAL COSTS =												\$6,186,974.77	\$70,010.04	\$891,472.00	\$15,640,538.76

BREAKDOWN OF ROAD CROSSING COST

ROAD CROSSING	DESIGN SECTION	ROAD WIDTH (FEET)	BRIDGE LENGTH (FEET)	ROAD CROSSING COST
LAKE LAMOND RD	HA-1	NI	NI	\$0.00
H.G. MOSELY	HA-1	66	118	\$319,440.00
HWY 80	HA-1	66	105	\$290,400.00
WARD	HA-2	33	102	\$123,585.00
BOSCOE	HA-2	33	97.5	\$118,387.50
LINCOLN	HA-2	33	90	\$109,725.00
KENWOOD	HA-2	33	71.5	\$88,357.50
AVE B	HA-2	33	78.5	\$94,132.50
SHOFNER/W FAIRMONT	HA-2	66	76.5	\$215,160.00
LOOP 281	HA-3	66	87	\$190,080.00
REEL ROAD	HA-5	66	83.5	\$180,840.00
EVERGREEN	HA-5	33	58.5	\$73,342.50
LYNWOOD	HA-5	33	58.5	\$73,342.50
SWAN ST	HA-5	33	44	\$58,585.00
TOTAL COSTS =				\$1,933,387.50
WARD DR	HA(T)-1	33	57.5	\$72,187.50
TEXAS AND PAC RR	HA(T)-1			\$0.00
TOTAL COSTS =				\$72,187.50
RODDEN DR	HA(T)-2	33	50.5	\$64,102.50
TOTAL COSTS =				\$64,102.50
RODDEN DR	HA(T)-3	33	47.5	\$60,837.50
TOTAL COSTS =				\$60,837.50

TABLE C-8
 CHANNEL QUANTITY AND COST CALCULATIONS
 HARRIS CREEK/DRAIN NO. 4 WATERSHED

BREAKDOWN OF ROAD CROSSING COST

ROAD CROSSING	DESIGN SECTION	ROAD WIDTH (FEET)	BRIDGE LENGTH (FEET)	ROAD CROSSING COST
AVENUE B	DR4-1	53	84	\$146,280.00
LOOP 281	DR4-1	66	44	\$129,360.00
LANE WELLS	DR4-1	66	44	\$129,360.00
PINE TREE RD	DR4-1	66	44	\$129,360.00
GOLF CREST	DR4-1	33	30	\$40,425.00
SCENIC DR	DR4-1	33	35	\$46,200.00
TOTAL COSTS=				\$620,985.00

* TOTAL COSTS OF EACH WATERSHED INCLUDES BRIDGE COST PLUS 20% CONTINGENCY AND ENGINEERING FEE

NOTES:

- 1) TYPE = CHANNEL MATERIAL, WHERE: 1 - CONCRETE, 2 - GRASS/CONCRETE, 3 - GRASS, 4 - NO IMPROVEMENT
- 2) CY/LF = CUBIC YARDS/LINEAR FOOT
- 3) SF/LF = SQUARE FEET/LINEAR FOOT
- 4) NI = NO IMPROVEMENTS

TABLE C-9
CHANNEL QUANTITY AND COST CALCULATIONS
HAWKINS/ LA FAMO CREEK WATERSHED

TRIBUTARY INFORMATION

WATERSHED	TYPE	LENGTH (FEET)	BOTTOM WIDTH (FEET)	DEPTH (FEET)	NUMBER DROPS	UNIT CONC. (CY/LF)	UNIT SEEDING (SF/LF)	EXCAVATION (CY)	DROP CONC. (CY)	CHANNEL CONC. (CY)	TOTAL SEEDING (SF)	COST CONC.	COST SEEDING	COST CUT/FILL	COST TOTAL
HAWKINS CREEK															
HK(T) - 1	3	958	120	6.57	0	0.00	161.06	22069	0	0.00	154298	\$0.00	\$12,000.95	\$88,278.00	\$100,278.95
	3	1285	120	7.14	0	0.00	164.63	26139	0	0.00	211543	\$0.00	\$18,453.35	\$104,558.00	\$121,009.35
	3	2928	90	8.02	0	0.00	140.12	62181	0	0.00	410288	\$0.00	\$31,911.13	\$248,724.00	\$280,635.13
	3	2047	90	7.38	0	0.00	136.00	22520	0	0.00	278392	\$0.00	\$21,652.71	\$90,080.00	\$111,732.71
	3	1546	70	5.85	0	0.00	108.56	12894	0	0.00	184746	\$0.00	\$12,813.55	\$51,576.00	\$64,389.55
	3	1060	55	5.88	0	0.00	91.75	8809	0	0.00	97255	\$0.00	\$7,584.28	\$35,238.00	\$42,800.28
	3	2302	55	5.80	0	0.00	91.25	13268	0	0.00	210058	\$0.00	\$16,337.81	\$53,084.00	\$69,401.81
	3	1178	15	5.00	0	0.00	46.25	779	0	0.00	54483	\$0.00	\$4,237.53	\$3,116.00	\$7,353.53
	3	599	15	4.30	2	0.00	41.88	1287	180	0.00	25083	\$54,000.00	\$1,950.91	\$5,148.00	\$81,098.91
3	850	15	4.88	0	0.00	44.13	1398	0	0.00	28681	\$0.00	\$2,230.78	\$5,584.00	\$7,814.78	
* TOTAL COSTS =												\$54,000.00	\$127,152.98	\$885,380.00	\$1,945,487.57
HK(T) - 1A	3	838	25	3.23	0	0.00	45.19	860	0	0.00	28739	\$0.00	\$2,235.28	\$2,840.00	\$4,875.28
	3	113	25	3.23	1	0.00	45.19	3081	150	0.00	5106	\$45,000.00	\$397.15	\$12,244.00	\$57,641.15
* TOTAL COSTS =												\$45,000.00	\$2,632.42	\$14,884.00	\$142,933.71
HK(T) - 1B	3	1343	55	4.29	0	0.00	81.81	768	0	0.00	109874	\$0.00	\$8,545.77	\$3,064.00	\$11,809.77
	3	877	55	3.71	1	0.00	78.19	1180	330	0.00	52933	\$99,000.00	\$4,117.01	\$4,840.00	\$107,757.01
	3	830	20	4.09	0	0.00	45.56	607	0	0.00	28704	\$0.00	\$2,232.58	\$2,428.00	\$4,660.58
	3	430	10	4.61	0	0.00	38.81	87	0	0.00	18889	\$0.00	\$1,298.06	\$348.00	\$1,646.06
	3	1252	10	4.23	1	0.00	36.44	312	60	0.00	45620	\$18,000.00	\$3,548.20	\$1,248.00	\$22,796.20
* TOTAL COSTS =												\$117,000.00	\$19,741.60	\$11,728.00	\$185,513.53
HK(T) - 1C	3	380	30	3.55	0	0.00	52.19	211	0	0.00	19831	\$0.00	\$1,542.43	\$844.00	\$2,386.43
	3	285	30	3.04	1	0.00	49.00	158	180	0.00	13985	\$54,000.00	\$1,086.17	\$632.00	\$55,718.17
	3	482	30	3.34	0	0.00	50.88	267	0	0.00	24522	\$0.00	\$1,907.25	\$1,088.00	\$2,975.25
	3	260	30	3.04	1	0.00	49.00	58	180	0.00	12740	\$54,000.00	\$990.89	\$232.00	\$55,222.89
	3	1323	30	3.25	0	0.00	50.31	294	0	0.00	68583	\$0.00	\$5,177.18	\$1,178.00	\$6,353.18
* TOTAL COSTS =												\$108,000.00	\$10,703.89	\$3,952.00	\$157,887.07
HK(T) - 1D	3	170	20	3.52	0	0.00	42.00	120	0	0.00	7140	\$0.00	\$555.33	\$480.00	\$1,035.33
	3	853	20	4.00	0	0.00	45.00	460	0	0.00	29385	\$0.00	\$2,285.50	\$1,840.00	\$4,125.50
	3	385	20	3.52	0	0.00	42.00	188	0	0.00	16170	\$0.00	\$1,257.87	\$752.00	\$2,009.87
	3	850	20	4.00	0	0.00	45.00	217	0	0.00	29250	\$0.00	\$2,275.00	\$888.00	\$3,143.00
	3	227	20	3.52	1	0.00	42.00	78	120	0.00	9534	\$38,000.00	\$741.53	\$304.00	\$37,045.53
* TOTAL COSTS =												\$38,000.00	\$7,115.03	\$4,244.00	\$58,830.84

TABLE C-9
CHANNEL QUANTITY AND COST CALCULATIONS
HAWKINS/ LA FAMO CREEK WATERSHED

WATERSHED	TYPE	LENGTH (FEET)	BOTTOM WIDTH (FEET)	DEPTH (FEET)	NUMBER DROPS	UNIT CONC. (CY/LF)	UNIT SEEDING (SF/LF)	EXCAVATION (CY)	DROP CONC. (CY)	CHANNEL CONC. (CY)	TOTAL SEEDING (SF)	COST CONC.	COST SEEDING	COST CUT/FILL	COST TOTAL
HK(T)-1E	3	260	25	2.38	1	0.00	39.75	587	150	0.00	10335	\$45,000.00	\$803.83	\$2,348.00	\$48,151.83
	3	521	10	4.25	0	0.00	36.58	711	0	0.00	19049	\$0.00	\$1,481.59	\$2,844.00	\$4,325.59
* TOTAL COSTS =												\$45,000.00	\$2,285.43	\$5,192.00	\$52,477.43
HK(T)-2	3	740	45	4.87	0	0.00	74.19	3700	0	0.00	54899	\$0.00	\$4,289.90	\$14,800.00	\$19,069.90
	3	835	40	4.78	0	0.00	89.75	428	0	0.00	44291	\$0.00	\$3,444.87	\$1,712.00	\$5,156.87
	3	190	40	5.04	1	0.00	71.50	99	240	0.00	13585	\$72,000.00	\$1,058.81	\$398.00	\$73,452.81
	3	2093	30	5.71	1	0.00	85.89	5733	180	0.00	137484	\$54,000.00	\$10,893.20	\$22,932.00	\$87,825.20
	3	550	30	3.93	0	0.00	54.56	1089	0	0.00	30009	\$0.00	\$2,334.08	\$4,278.00	\$6,610.08
	3	458	25	4.03	0	0.00	50.19	882	0	0.00	22988	\$0.00	\$1,787.79	\$3,528.00	\$5,315.79
	3	1121	20	4.78	1	0.00	49.88	1391	120	0.00	55910	\$38,000.00	\$4,348.55	\$5,584.00	\$45,912.55
* TOTAL COSTS =												\$162,000.00	\$27,834.98	\$53,208.00	\$308,331.58
HK(T)-3	3	480	40	6.41	0	0.00	80.08	3040	0	0.00	38430	\$0.00	\$2,989.00	\$12,160.00	\$15,149.00
	3	1708	25	8.43	0	0.00	77.89	10481	0	0.00	132890	\$0.00	\$10,320.35	\$41,924.00	\$52,244.35
	3	791	25	7.98	0	0.00	74.88	4209	0	0.00	59228	\$0.00	\$4,808.48	\$18,838.00	\$21,442.48
	3	541	25	7.32	0	0.00	70.75	2588	0	0.00	38278	\$0.00	\$2,977.00	\$10,284.00	\$13,241.00
	3	904	25	4.89	0	0.00	55.58	2377	0	0.00	50229	\$0.00	\$3,908.88	\$9,508.00	\$13,414.88
	3	1368	25	4.58	2.5	0.00	53.83	1403	375	0.00	73252	\$112,500.00	\$5,897.36	\$5,812.00	\$123,809.38
	3	720	20	4.50	0	0.00	48.13	293	0	0.00	34850	\$0.00	\$2,895.00	\$1,172.00	\$3,867.00
* TOTAL COSTS =												\$112,500.00	\$33,191.85	\$97,478.00	\$329,001.42
LA FAMO															
LA-1	3	2210	85	7.30	0	0.00	130.83	44500	0	0.00	288881	\$0.00	\$22,452.99	\$178,000.00	\$200,452.99
LA-1	3	1900	70	7.90	1	0.00	119.38	43800	420	0.00	228813	\$128,000.00	\$17,840.97	\$175,200.00	\$318,840.97
LA-2	3	1900	30	7.70	0	0.00	78.12	18800	0	0.00	148438	\$0.00	\$11,545.14	\$87,200.00	\$78,745.14
LA-3	3	1970	30	5.30	2	0.00	83.13	20500	380	0.00	124358	\$108,000.00	\$9,872.15	\$82,000.00	\$199,872.15
LA-3	3	1660	20	5.20	2	0.00	52.50	8900	240	0.00	87150	\$72,000.00	\$8,778.33	\$27,800.00	\$108,378.33
* TOTAL COSTS =												\$308,000.00	\$68,089.58	\$530,000.00	\$1,480,907.50

LA FAMO TRIBUTARY INFORMATION

WATERSHED	TYPE	LENGTH (FEET)	BOTTOM WIDTH (FEET)	DEPTH (FEET)	NUMBER DROPS	UNIT CONC. (CY/LF)	UNIT SEEDING (SF/LF)	EXCAVATION (CY)	DROP CONC. (CY)	CHANNEL CONC. (CY)	TOTAL SEEDING (SF)	COST CONC.	COST SEEDING	COST CUT/FILL	COST TOTAL
LA(T)-1A	3	2000	40	6.27	0	0.00	79.19	4741	0	0.00	158375	\$0.00	\$12,318.08	\$18,964.00	\$31,282.08
LA(T)-1A	3	820	40	5.63	0	0.00	75.19	2493	0	0.00	61854	\$0.00	\$4,795.29	\$9,872.00	\$14,787.29
LA(T)-1A,1B	3	1020	40	5.40	1	0.00	73.75	3102	240	0.00	75225	\$72,000.00	\$5,850.83	\$12,408.00	\$90,258.83
LA(T)-1B	3	425	30	3.51	0	0.00	51.94	877	0	0.00	22073	\$0.00	\$1,718.82	\$2,708.00	\$4,424.82
LA(T)-1B	3	815	30	3.92	0	0.00	54.50	799	0	0.00	33518	\$0.00	\$2,808.92	\$3,198.00	\$5,802.92
LA(T)-1B	3	450	30	3.80	0	0.00	52.50	233	0	0.00	23625	\$0.00	\$1,837.50	\$932.00	\$2,769.50
LA(T)-1B	3	285	30	3.50	0	0.00	51.88	137	0	0.00	13747	\$0.00	\$1,089.20	\$548.00	\$1,617.20
LA(T)-1B	3	925	15	4.55	0	0.00	43.44	1848	0	0.00	40180	\$0.00	\$3,125.09	\$7,392.00	\$10,517.09
LA(T)-1B	3	225	15	3.98	1	0.00	39.88	389	90	0.00	8972	\$27,000.00	\$897.81	\$1,558.00	\$29,253.81
LA(T)-1B	3	520	15	4.17	1	0.00	41.08	638	90	0.00	21353	\$27,000.00	\$1,860.75	\$2,544.00	\$31,204.75
LA(T)-1B	3	410	15	3.98	1	0.00	39.88	501	90	0.00	18349	\$27,000.00	\$1,271.57	\$2,004.00	\$30,275.57
* TOTAL COSTS =												\$153,000.00	\$38,949.84	\$82,224.00	\$302,608.81

TABLE C-8
CHANNEL QUANTITY AND COST CALCULATIONS
HAWKINS/ LA FAMO CREEK WATERSHED

WATERSHED	TYPE	LENGTH (FEET)	BOTTOM WIDTH (FEET)	DEPTH (FEET)	NUMBER DROPS	UNIT CONC. (CY/LF)	UNIT SEEDING (SF/LF)	EXCAVATION (CY)	DROP CONC. (CY)	CHANNEL CONC. (CY)	TOTAL SEEDING (SF)	COST CONC.	COST SEEDING	COST CUT/FILL	COST TOTAL
LA(T)-1C	3	70	50	2.16	0	0.00	63.50	26	0	0.00	4445	\$0.00	\$345.72	\$104.00	\$449.72
	3	180	40	2.60	1	0.00	58.25	67	240	0.00	10125	\$72,000.00	\$787.50	\$268.00	\$73,055.50
	3	470	25	3.30	0	0.00	45.63	174	0	0.00	21444	\$0.00	\$1,667.85	\$696.00	\$2,363.85
	3	630	25	3.60	0	0.00	47.50	587	0	0.00	29925	\$0.00	\$2,327.50	\$2,346.00	\$4,675.50
	3	600	20	3.41	1	0.00	41.31	200	120	0.00	24788	\$36,000.00	\$1,927.92	\$800.00	\$38,727.92
* TOTAL COSTS =												\$108,000.00	\$7,056.49	\$4,216.00	\$143,126.98
LA(T)-2	3	540	25	2.66	1	0.00	41.63	620	150	0.00	22478	\$45,000.00	\$1,748.25	\$2,480.00	\$49,228.25
	3	560	20	3.31	0	0.00	40.69	181	0	0.00	22785	\$0.00	\$1,772.17	\$644.00	\$2,416.17
	3	320	20	2.64	0	0.00	37.75	0	0	0.00	12080	\$0.00	\$939.56	\$0.00	\$939.56
* TOTAL COSTS =												\$45,000.00	\$4,459.97	\$3,124.00	\$53,100.77
TOTAL WATERSHED COST															
TOTAL COSTS =												\$679,500.00	\$230,758.19	\$676,044.00	\$5,167,997.00

BREAKDOWN OF ROAD CROSSING COSTS

ROAD CROSSING	DESIGN SECTION	ROAD WIDTH (FEET)	BRIDGE LENGTH (FEET)	ROAD CROSSING COST
DUMAS RD	HK(T)-1	33	163	\$194,040.00
BRENT RD		33	134	\$160,545.00
HWY 1845		66	105	\$290,400.00
HARLEY RIDGE N		33	90	\$109,725.00
TOTAL COSTS =				\$754,710.00
SNODDY RD	HK(T)-1A	33	44	\$56,595.00
TOTAL COSTS =				\$56,595.00
YARBOROUGH RD	HK(T)-1B	33	35	\$6,125.00
TOTAL COSTS =				\$6,125.00
HWY 1845	HK(T)-1C	66	50	\$6,750.00
TOTAL COSTS =				\$6,750.00
HARLEY RIDGE N	HK(T)-2	33	69	\$13,800.00
TOTAL COSTS =				\$13,800.00

TABLE C-9
 CHANNEL QUANTITY AND COST CALCULATIONS
 HAWKINS/ LA FAMO CREEK WATERSHED

ROAD CROSSING	DESIGN SECTION	ROAD WIDTH (FEET)	BRIDGE LENGTH (FEET)	ROAD CROSSING COST
BACLE ROAD	HK(T)-3	33	79	\$15,800.00
MEADOWVIEW RD		33	78	\$15,200.00
				TOTAL COSTS= \$31,000.00
LAFAMO RD	LA(T)-1A	66	120	\$330,000.00
				TOTAL COSTS= \$330,000.00

* TOTAL COSTS OF EACH WATERSHED INCLUDES BRIDGE COST PLUS 20% CONTINGENCY AND ENGINEERING FEE

NOTES:

- 1) TYPE = CHANNEL MATERIAL, WHERE: 1- CONCRETE, 2- GRASS/CONCRETE, 3- GRASS, 4- NO IMPROVEMENT
- 2) CY/LF = CUBIC YARDS/LINEAR FOOT
- 3) SF/LF = SQUARE FEET/LINEAR FOOT

TABLE C-10
CHANNEL QUANTITY AND COST CALCULATIONS
IRON BRIDGE CREEK WATERSHED

WATERSHED	TYPE	LENGTH (FEET)	BOTTOM WIDTH (FEET)	DEPTH (FEET)	NUMBER DROPS	UNIT CONC. (CY/LF)	UNIT SEEDING (SF/LF)	EXCAVATION (CY)	DROP CONC. (CY)	CHANNEL CONC. (CY)	TOTAL SEEDING (SF)	COST CONC.	COST SEEDING	COST CUT/FILL	COST TOTAL
IRON BRIDGE CREEK															
IB-1	3	1100	50	11.00	0	0.00	118.75	23600	0	0.00	130625	\$0.00	\$10,159.72	\$94,400.00	\$104,559.72
IB-2	3	3400	40	10.00	0	0.00	102.50	51100	0	0.00	348500	\$0.00	\$27,105.56	\$204,400.00	\$231,505.56
IB-3	3	3000	40	10.00	0	0.00	102.50	28400	0	0.00	307500	\$0.00	\$23,918.67	\$113,600.00	\$137,518.67
IB-4	1	1550	12	8.50	0	0.66	0.00	2300	0	1030.50	0	\$309,150.60	\$0.00	\$9,200.00	\$318,350.60
IB-5	4											\$0.00	\$0.00	\$0.00	\$0.00
IB-6	1	2500	10	7.00	0	0.55	0.00	5300	0	1374.25	0	\$412,275.00	\$0.00	\$21,200.00	\$433,475.00
IB-6	1	1650	10	5.00	0	0.45	0.00	1100	0	735.41	0	\$220,621.50	\$0.00	\$4,400.00	\$225,021.50
* TOTAL COSTS=												\$942,047.10	\$61,181.94	\$447,200.00	\$2,867,674.85
TRIBUTARY INFORMATION															
IB(T)-1	3	6400	20	9.00	0	0.00	76.25	68000	0	0.00	488000	\$0.00	\$37,955.56	\$272,000.00	\$309,955.56
IB(T)-1	3	1700	10	7.50	0	0.00	56.88	10000	0	0.00	96688	\$0.00	\$7,520.14	\$40,000.00	\$47,520.14
* TOTAL COSTS=												\$0.00	\$45,475.69	\$312,000.00	\$1,632,270.83
TOTAL WATERSHED COSTS															
TOTAL COSTS=												\$942,047.10	\$106,657.64	\$759,200.00	\$4,499,945.69
BREAKDOWN OF ROAD CROSSING COSTS															
ROAD CROSSING	SECTION	ROAD WIDTH (FEET)	BRIDGE LENGTH (FEET)	ROAD CROSSING COST											
IH 20 BOX CULVS	IB-2		260	\$200,000.00											
ESTES PRKY	IB-3	72	110	\$331,200.00											
WELLS DR	IB-5	36	50	\$69,300.00											
RANEY DR	IB-5	36	50	\$69,300.00											
LEMMONS ST	IB-5	36	50	\$69,300.00											
BIRDSONG ST	IB-6	36	50	\$69,300.00											
12th ST	IB-6	34	50	\$65,450.00											
DEAN ST	IB-6	34	50	\$65,450.00											
TOTAL COSTS=												\$939,300.00			
ESTES PRKWAY	IB(T)-1	40	250	\$357,000.00											
IH 20	IB(T)-1	30	500	\$530,250.00											
SWANCY ST	IB(T)-1	30	50	\$57,750.00											
PITTMAN ST	IB(T)-1	30	50	\$57,750.00											
TOTAL COSTS=												\$1,002,750.00			

* TOTAL COSTS OF EACH WATERSHED INCLUDES BRIDGE COST PLUS 20% CONTINGENCY AND ENGINEERING FEE

NOTES:

- 1) TYPE = CHANNEL MATERIAL, WHERE: 1-CONCRETE, 2-GRASS/CONCRETE, 3-GRASS, 4-NO IMPROVEMENT
- 2) CY/LF = CUBIC YARDS/LINEAR FOOT
- 3) SF/LF = SQUARE FEET/LINEAR FOOT

TABLE C-11
CHANNEL QUANTITY AND COST CALCULATIONS
JOHNSON WATERSHED

WATERSHED	TYPE	LENGTH (FEET)	BOTTOM WIDTH (FEET)	DEPTH (FEET)	NUMBER DROPS	UNIT CONC. (CY/LF)	UNIT SEEDING (SF/LF)	EXCAVATION (CY)	DROP CONC. (CY)	CHANNEL CONC. (CY)	TOTAL SEEDING (SF)	COST CONC.	COST SEEDING	COST CUT/FILL	COST TOTAL
JOHNSON															
JO-1	2	755	20	8.80	0	0.54	20.87	4000	0	409.97	15758	\$122,989.50	\$1,225.59	\$18,000.00	\$140,215.09
JO-1	2	850	20	8.20	0	0.53	19.81	800	0	348.19	12744	\$103,857.00	\$991.20	\$3,200.00	\$108,048.20
JO-1	1	250	20	8.10	0	0.89	0.00	300	0	172.15	0	\$51,845.00	\$0.00	\$1,200.00	\$52,845.00
JO-1	1	720	15	7.20	2	0.85	0.00	1400	97.5	470.12	0	\$170,287.20	\$0.00	\$5,800.00	\$175,887.20
JO-1	2	250	15	7.20	1	0.47	22.77	300	52.5	118.44	5892	\$50,881.25	\$442.72	\$1,200.00	\$52,323.97
JO-1	2	1330	15	6.70	4	0.45	21.19	3000	210	602.18	28179	\$243,847.25	\$2,191.70	\$12,000.00	\$257,838.95
JO-2	1	135	10	6.40	1	0.52	0.00	400	32.5	70.00	0	\$30,749.25	\$0.00	\$1,800.00	\$32,349.25
JO-2	4	0	0	0.00	0	0.00	0.00	0	0	0.00	0	\$0.00	\$0.00	\$0.00	\$0.00
JO-2	3	940	30	4.50	0	0.00	58.13	2000	0	0.00	54838	\$0.00	\$4,249.58	\$8,000.00	\$12,249.58
JO-2	3	840	25	4.80	0	0.00	53.75	2500	0	0.00	34400	\$0.00	\$2,875.58	\$10,000.00	\$12,875.58
JO-2	2	430	15	5.30	0	0.42	18.78	800	0	179.03	7207	\$53,709.15	\$560.53	\$3,200.00	\$57,469.68
JO-2	1	590	15	3.50	0	0.48	0.00	700	0	271.72	0	\$81,517.35	\$0.00	\$2,800.00	\$84,317.35
JO-2	1	200	15	3.80	0	0.47	0.00	200	0	93.15	0	\$27,945.00	\$0.00	\$800.00	\$28,745.00
JO-2	1	450	15	4.10	0	0.49	0.00	200	0	221.29	0	\$88,388.25	\$0.00	\$800.00	\$89,188.25
JO-2	1	200	15	3.80	1	0.48	0.00	400	48.75	95.23	0	\$43,194.00	\$0.00	\$1,800.00	\$44,794.00
JO-2	1	200	15	3.80	0	0.47	0.00	400	0	93.15	0	\$27,945.00	\$0.00	\$1,800.00	\$29,545.00
JO-2	1	510	20	2.30	0	0.49	0.00	800	0	250.41	0	\$75,123.00	\$0.00	\$2,400.00	\$77,523.00
JO-2	1	530	15	2.00	0	0.38	0.00	800	0	202.75	0	\$80,825.45	\$0.00	\$2,400.00	\$83,225.45
* TOTAL COSTS =												\$1,210,501.85	\$12,336.89	\$74,400.00	\$2,371,030.24

TRIBUTARY INFORMATION

WATERSHED	TYPE	LENGTH (FEET)	BOTTOM WIDTH (FEET)	DEPTH (FEET)	NUMBER DROPS	UNIT CONC. (CY/LF)	UNIT SEEDING (SF/LF)	EXCAVATION (CY)	DROP CONC. (CY)	CHANNEL CONC. (CY)	TOTAL SEEDING (SF)	COST CONC.	COST SEEDING	COST CUT/FILL	COST TOTAL
JO(T)-1	3	220	15	4.00	0	0.00	40.00	171	0	0.00	8800	\$0.00	\$884.44	\$884.00	\$1,368.44
	1	830	15	3.70	2	0.47	0.00	846	97.8	390.89	0	\$148,518.55	\$0.00	\$2,584.00	\$149,100.55
	3	850	10	4.23	1	0.00	38.44	598	80	0.00	30972	\$18,000.00	\$2,408.92	\$2,392.00	\$22,800.92
* TOTAL COSTS =												\$184,518.55	\$3,093.37	\$8,660.00	\$203,450.90
TOTAL WATERSHED COST															
TOTAL COSTS =												\$1,375,018.20	\$18,430.25	\$80,000.00	\$2,654,460.14

TABLE C-11
CHANNEL QUANTITY AND COST CALCULATIONS
JOHNSON WATERSHED

BREAKDOWN OF ROAD CROSSINGS COSTS

ROAD CROSSING	DESIGN SECTION	ROAD WIDTH (FEET)	BRIDGE LENGTH (FEET)	ROAD CROSSING COST
TRIPLE CREEK DR	JO-1	33	48	\$58,905.00
HOYT	JO-1	33	32	\$42,735.00
EDEN	JO-1	53	29	\$72,080.00
DELWOOD	JO-2	NI	NI	\$0.00
HOLLEY BROOK	JO-2	66	57	\$163,680.00
AIRLINE	JO-2	66	53	\$153,120.00
DRAKE BLVD	JO-2	33	22	\$31,185.00
COMMANDER	JO-2	33	22	\$31,185.00
SKYLINE DR	JO-2	33	25	\$34,650.00
CLAY ST	JO-2	33	19	\$27,720.00
LOOP 281	JO-2	66	19	\$63,360.00
				TOTAL COSTS= \$678,620.00
JUDSON RD	JO(T)-1	66	22	\$71,280.00
				TOTAL COSTS= \$71,280.00

* TOTAL COSTS OF EACH WATERSHED INCLUDES BRIDGE COST PLUS 20% CONTINGENCY AND ENGINEERING FEE

NOTES:

- 1) TYPE = CHANNEL MATERIAL, WHERE: 1- CONCRETE, 2- GRASS/CONCRETE, 3- GRASS, 4- NO IMPROVEMENT
- 2) CY/LF = CUBIC YARDS/LINEAR FOOT
- 3) SF/LF = SQUARE FEET/LINEAR FOOT
- 4) NI = NO IMPROVEMENT

TABLE C-12
CHANNEL QUANTITY AND COST CALCULATIONS
MCCANN CREEK WATERSHED

WATERSHED	TYPE	LENGTH (FEET)	BOTTOM WIDTH (FEET)	DEPTH (FEET)	NUMBER DROPS	UNIT CONC. (CY/LF)	UNIT SEEDING (SF/LF)	EXCAVATION (CY)	DROP CONC. (CY)	CHANNEL CONC. (CY)	TOTAL SEEDING (SF)	COST CONC.	COST SEEDING	COST CUT/FILL	COST TOTAL
MCCANN CREEK															
MC-1	3	2080	60	5.40	0	0.00	93.75	5960	0	0.00	195000	\$0.00	\$15,166.87	\$23,840.00	\$39,006.87
MC-1	3	560	60	5.80	0	0.00	96.25	9700	0	0.00	53900	\$0.00	\$4,192.22	\$38,800.00	\$42,992.22
MC-2	2	910	35	6.30	0	0.81	19.92	3600	0	740.51	18129	\$222,153.75	\$1,410.08	\$14,400.00	\$237,963.81
MC-2	3	790	35	5.60	1	0.00	70.00	6800	210	0.00	55300	\$63,000.00	\$4,301.11	\$27,200.00	\$94,501.11
MC-3	3	1850	20	5.40	0	0.00	53.75	5700	0	0.00	99438	\$0.00	\$7,734.03	\$22,800.00	\$30,534.03
MC-3	3	850	20	5.00	0	0.00	51.25	2300	0	0.00	43563	\$0.00	\$3,388.19	\$9,200.00	\$12,588.19
MC-4	3	1100	10	4.10	0	0.00	35.62	1200	0	0.00	39188	\$0.00	\$3,047.92	\$4,800.00	\$7,847.92
* TOTAL COSTS =												\$285,153.75	\$39,240.20	\$141,040.00	\$697,120.74

TRIBUTARY INFORMATION

WATERSHED	TYPE	LENGTH (FEET)	BOTTOM WIDTH (FEET)	DEPTH (FEET)	NUMBER DROPS	UNIT CONC. (CY/LF)	UNIT SEEDING (SF/LF)	EXCAVATION (CY)	DROP CONC. (CY)	CHANNEL CONC. (CY)	TOTAL SEEDING (SF)	COST CONC.	COST SEEDING	COST CUT/FILL	COST TOTAL
MC(T)-1	3	470	20	3.80	0	0.00	43.75	244	0	0.00	20563	\$0.00	\$1,599.31	\$978.00	\$2,575.31
	3	860	20	3.68	1	0.00	43.00	938	120	0.00	36960	\$36,000.00	\$2,876.22	\$3,752.00	\$42,628.22
* TOTAL COSTS =												\$36,000.00	\$4,475.53	\$4,728.00	\$54,244.23
MC(T)-2	3	600	20	3.50	0	0.00	41.88	0	0	0.00	25125	\$0.00	\$1,954.17	\$0.00	\$1,954.17
	3	800	20	3.61	0	0.00	42.56	0	0	0.00	25538	\$0.00	\$1,986.25	\$0.00	\$1,986.25
	3	720	15	4.18	0	0.00	41.00	0	0	0.00	29520	\$0.00	\$2,296.00	\$0.00	\$2,296.00
	3	380	5	4.65	1	0.00	34.06	454	30	0.00	12944	\$9,000.00	\$1,006.74	\$1,816.00	\$11,822.74
* TOTAL COSTS =												\$9,000.00	\$7,243.15	\$1,816.00	\$21,670.88
MC(T)-3	3	1665	5	4.09	0	0.00	30.56	0	0	0.00	50867	\$0.00	\$3,957.84	\$0.00	\$3,957.84
* TOTAL COSTS =												\$0.00	\$3,957.84	\$0.00	\$4,749.41
TOTAL WATERSHED COSTS															
TOTAL COSTS =												\$330,153.75	\$54,918.72	\$147,584.00	\$777,785.37

BREAKDOWN OF ROAD CROSSING COSTS

ROAD CROSSING	DESIGN SECTION	ROAD WIDTH (FEET)	BRIDGE LENGTH (FEET)	ROAD CROSSING COST
GREY STONE	MC-1	33	95	\$115,500.00
TOTAL COSTS =				\$115,500.00

* TOTAL COSTS OF EACH WATERSHED INCLUDES BRIDGE COST PLUS 20% CONTINGENCY AND ENGINEERING FEE

NOTES:

- 1) TYPE = CHANNEL MATERIAL, WHERE: 1-CONCRETE, 2-GRASS/CONCRETE, 3-GRASS, 4-NO IMPROVEMENT
- 2) CY/LF = CUBIC YARDS/LINEAR FOOT
- 3) SF/LF = SQUARE FEET/LINEAR FOOT

TABLE C-13
CHANNEL QUANTITY AND COST CALCULATIONS
OAKLAND CREEK WATERSHED

WATERSHED	TYPE	LENGTH (FEET)	BOTTOM WIDTH (FEET)	DEPTH (FEET)	NUMBER DROPS	UNIT CONC (CY/LF)	UNIT EARTH (SF/LF)	EXCAVATION (CY)	DROP CONC. (CY)	CHANNEL CONC. (CY)	TOTAL SEEDING (SF)	COST CONC.	COST SEEDING	COST CUT/FILL	COST TOTAL
OAKLAND CREEK															
OA-1	3	1160	125	6.00	0	0.00	162.50	17400	0	0.00	188500	\$0.00	\$14,661.11	\$69,600.00	\$84,261.11
OA-1	1	860	50	8.00	0	1.34	0.00	8200	0	1156.27	0	\$346,881.00	\$0.00	\$32,800.00	\$379,681.00
OA-1	2	1840	55	7.60	1	1.22	24.03	23500	192.5	1999.08	39415	\$657,473.40	\$3,065.58	\$94,000.00	\$754,538.98
OA-2	3	2245	75	6.40	0	0.00	115.00	33900	0	0.00	258175	\$0.00	\$20,060.26	\$136,800.00	\$156,860.26
OA-2	2	1170	80	4.20	0	1.59	13.28	7200	0	1865.92	15539	\$559,774.80	\$1,206.62	\$26,800.00	\$569,783.42
OA-2	2	1570	70	5.30	0	1.44	16.76	15700	0	2257.19	26313	\$677,156.70	\$2,046.59	\$62,800.00	\$742,003.29
OA-2	2	2250	55	6.30	0	1.19	19.92	48200	0	2666.59	44825	\$799,976.25	\$3,466.41	\$192,800.00	\$996,262.66
OA-2	2	375	55	3.40	2	1.11	10.75	9200	385	416.16	4032	\$240,346.66	\$313.59	\$36,800.00	\$277,460.47
OA-3	2	1150	55	3.00	0	1.10	9.49	400	0	1264.25	10910	\$379,275.75	\$848.54	\$1,800.00	\$381,724.29
OA-3	3	2445	40	5.50	1	0.00	74.38	22100	240	0.00	181847	\$72,000.00	\$14,143.65	\$88,400.00	\$174,543.65
OA-3	3	1400	25	4.90	0	0.00	55.63	52400	0	0.00	77875	\$0.00	\$6,056.94	\$209,600.00	\$215,656.94

* TOTAL COSTS= \$3,732,884.78 \$65,911.32 \$932,800.00 \$7,364,583.32

TRIBUTARY INFORMATION

WATERSHED	TYPE	LENGTH (FEET)	BOTTOM WIDTH (FEET)	DEPTH (FEET)	NUMBER DROPS	UNIT CONC. (CY/LF)	UNIT EARTH (SF/LF)	EXCAVATION (CY)	DROP CONC. (CY)	CHANNEL CONC. (CY)	TOTAL SEEDING (SF)	COST CONC.	COST SEEDING	COST CUT/FILL	COST TOTAL
OA(T)-1	3	680	55	3.90	0	0.00	79.38	1888	0	0.00	53975	\$0.00	\$4,198.06	\$6,752.00	\$10,950.06
	3	800	30	3.90	0	0.00	54.38	1764	0	0.00	43500	\$0.00	\$3,383.33	\$7,056.00	\$10,439.33
	3	610	30	3.90	1	0.00	54.38	913	180	0.00	33169	\$54,000.00	\$2,579.79	\$3,652.00	\$60,231.79
	3	610	10	5.80	4	0.00	46.25	1227	240	0.00	37463	\$72,000.00	\$2,913.75	\$4,908.00	\$79,821.75

* TOTAL COSTS= \$126,000.00 \$13,074.93 \$22,366.00 \$640,419.52

TOTAL WATERSHED COSTS

TOTAL COSTS= \$3,858,884.78 \$78,986.25 \$975,166.00 \$8,005,012.83

BREAKDOWN OF ROAD CROSSING COSTS

ROAD CROSSING	DESIGN SECTION	ROAD WIDTH (FEET)	BRIDGE LENGTH (FEET)	ROAD CROSSING COST
HOYT	OA-1	33	66	\$82,005.00
EDEN	OA-1	53	66	\$150,520.00
DELWOOD	OA-2	53	113	\$250,180.00
HOLLYBROOK DR	OA-2	66	97	\$269,260.00
FOURTH ST	OA-2	66	91	\$253,440.00
LOOP 281	OA-2	66	80	\$224,400.00
HWY 259	OA-3	66	54	\$155,760.00
				TOTAL COSTS= \$1,365,565.00
LOOP 281	OA(T)-1	66	76	\$219,120.00
HWY 259	OA(T)-1	66	53	\$153,120.00
				TOTAL COSTS= \$372,240.00

* TOTAL COSTS OF EACH WATERSHED INCLUDES BRIDGE COST PLUS 20% CONTINGENCY AND ENGINEERING FEE

NOTES:

- 1) TYPE = CHANNEL MATERIAL, WHERE: 1- CONCRETE, 2- GRASS/CONCRETE, 3- GRASS, 4- NO IMPROVEMENT
- 2) CY/LF = CUBIC YARDS/LINEAR FOOT
- 3) SF/LF = SQUARE FEET/LINEAR FOOT

TABLE C-14
CHANNEL QUANTITY AND COST CALCULATIONS
PETERSON COURT CREEK

WATERSHED	TYPE	LENGTH (FEET)	BOTTOM WIDTH (FEET)	DEPTH (FEET)	NUMBER DROPS	UNIT CONC. (CY/LF)	UNIT SEEDING (SF/LF)	EXCAVATION (CY)	DROP CONC. (CY)	CHANNEL CONC. (CY)	TOTAL SEEDING (SF)	COST CONC.	COST SEEDING	COST CUT/FILL	COST TOTAL
PETERSON COURT CREEK															
PC-1	+	1150				0.00	0.00		0	0.00	0	\$0.00	\$0.00	\$0.00	\$1,150,000.00
PC-1	1	1650	10	6.90	1	0.54	0.00	750	32.5	898.43	0	\$279,277.50	\$0.00	\$3,000.00	\$282,277.50
PC-1	1	1000	10	5.80	2	0.49	0.00	500	65	487.30	0	\$165,890.00	\$0.00	\$2,000.00	\$167,890.00
PC-1	1	850	10	4.20	1	0.40	0.00	375	32.5	262.67	0	\$88,549.50	\$0.00	\$1,500.00	\$90,049.50
PC-1	1	1400	8	3.80	0	0.35	0.00	500	0	484.62	0	\$145,387.20	\$0.00	\$2,000.00	\$147,387.20
* TOTAL COSTS =												\$678,904.20	\$0.00	\$6,500.00	\$2,613,161.04

BREAKDOWN OF ROAD CROSSING COSTS

ROAD CROSSING	DESIGN SECTION	ROAD WIDTH (FEET)	BRIDGE LENGTH (FEET)	ROAD CROSSING COST
HIGH ST	PC-1	66	38	\$113,520.00
SOUTH GREEN ST	PC-1	33	34	\$45,045.00
GLENN ST	PC-1	33	28	\$38,115.00
ARDEN ST	PC-1	33	24	\$33,495.00
RADIO ST	PC-1	33	24	\$33,495.00
BIRDSONG ST	PC-1	66	24	\$76,580.00
TOTAL COSTS =				\$340,230.00

+ THIS COST CORRESPONDS TO A 3-72" RCP CULVERT AROUND THE LETOURNEAU PLANT
* TOTAL COSTS OF EACH WATERSHED INCLUDES BRIDGE COST PLUS 20% CONTINGENCY AND ENGINEERING FEE

NOTES:

- 1) TYPE = CHANNEL MATERIAL, WHERE: 1- CONCRETE, 2- GRASS/CONCRETE, 3- GRASS, 4- NO IMPROVEMENT
- 2) CY/LF = CUBIC YARD/LINEAR FOOT
- 3) SF/LF = SQUARE FOOT/LINEAR FOOT

TABLE C-15
CHANNEL QUANTITY AND COST CALCULATIONS
RAY CREEK WATERSHED

WATERSHED	TYPE	LENGTH (FEET)	BOTTOM WIDTH (FEET)	DEPTH (FEET)	NUMBER DROPS	UNIT CONC. (CY/LF)	UNIT SEEDING (SF/LF)	EXCAVATION (CY)	DROP CONC. (CY)	CHANNEL CONC. (CY)	TOTAL SEEDING (SF)	COST CONC.	COST SEEDING	COST CUT/FILL	COST TOTAL
RAY CREEK															
RA-1A	4	0	0	0.00	0	0.00	0.00	0	0	0.00	0	\$0.00	\$0.00	\$0.00	\$0.00
RA-1B	2	1850	75	8.00	0	1.80	25.30	29850	0	2961.39	46802	\$686,416.25	\$3,640.13	\$119,400.00	\$1,011,456.38
RA-1B	2	2200	70	8.00	1	1.51	25.30	49150	245	3317.36	55856	\$1,066,714.00	\$4,326.81	\$196,800.00	\$1,268,842.81
RA-2	2	1840	70	7.90	0	1.51	24.98	35180	0	2789.75	45967	\$630,925.80	\$3,575.20	\$140,720.00	\$975,220.80
RA-3	2	3140	65	6.50	1	1.38	20.55	56110	227.5	4320.80	64542	\$1,364,489.10	\$5,019.94	\$224,440.00	\$1,593,949.04
RA-4	3	2400	65	6.00	2	0.00	102.50	115200	780	0.00	246000	\$234,000.00	\$19,133.33	\$460,800.00	\$713,933.33
RA-5	3	1140	50	6.00	2	0.00	87.50	54720	600	0.00	99750	\$180,000.00	\$7,756.33	\$218,880.00	\$406,636.33
RA-6	3	1830	15	6.00	4	0.00	52.50	87840	360	0.00	96075	\$106,000.00	\$7,472.50	\$351,360.00	\$466,832.50
RA-7	3	3200	25	3.58	0	0.00	47.38	3081	0	0.00	151600	\$0.00	\$11,791.11	\$12,324.00	\$24,115.11
RA-7	3	100	15	3.01	1	0.00	33.81	96	90	0.00	3381	\$27,000.00	\$262.99	\$384.00	\$27,646.99
* TOTAL COSTS =												\$4,674,544.95	\$50,928.25	\$1,712,200.00	\$7.00
TRIBUTARY INFORMATION															
WATERSHED	TYPE	LENGTH (FEET)	BOTTOM WIDTH (FEET)	DEPTH (FEET)	NUMBER DROPS	UNIT CONC. (CY/LF)	UNIT SEEDING (SF/LF)	EXCAVATION (CY)	DROP CONC. (CY)	CHANNEL CONC. (CY)	TOTAL SEEDING (SF)	COST CONC.	COST SEEDING	COST CUT/FILL	COST TOTAL
RA(T)-1	3	900	30	4.14	2	0.00	55.88	2990	360	0.00	50266	\$106,000.00	\$3,911.25	\$11,960.00	\$123,871.25
* TOTAL COSTS =												\$106,000.00	\$3,911.25	\$11,960.00	\$148,645.50
RA(T)-2	1	600	25	4.22	1	0.88	0.00	1355	81.25	410.21	0	\$147,439.20	\$0.00	\$5,420.00	\$152,859.20
RA(T)-2	3	900	20	4.80	0	0.00	48.75	1919	0	0.00	43875	\$0.00	\$3,412.50	\$7,676.00	\$11,086.50
* TOTAL COSTS =												\$147,439.20	\$3,412.50	\$13,096.00	\$168,737.24
RA(T)-3	3	130	25	4.00	0	0.00	50.00	0	0	0.00	6500	\$0.00	\$505.56	\$0.00	\$505.56
RA(T)-3	3	385	25	3.47	0	0.00	46.69	0	0	0.00	17975	\$0.00	\$1,396.03	\$0.00	\$1,396.03
* TOTAL COSTS =												\$0.00	\$1,903.59	\$0.00	\$2,284.30
RA(T)-4	3	1260	40	4.00	0	0.00	65.00	291	0	0.00	81900	\$0.00	\$6,370.00	\$1,164.00	\$7,534.00
* TOTAL COSTS =												\$0.00	\$6,370.00	\$1,164.00	\$9,040.80
RA(T)-5	3	830	10	3.90	0	0.00	34.36	2083	0	0.00	26531	\$0.00	\$2,219.10	\$6,332.00	\$10,551.10
* TOTAL COSTS =												\$0.00	\$2,219.10	\$6,332.00	\$12,661.32
TOTAL WATERSHED COST															
TOTAL COSTS =												\$4,929,984.15	\$68,744.68	\$1,746,752.00	\$389,376.16

TABLE C-15
CHANNEL QUANTITY AND COST CALCULATIONS
RAY CREEK WATERSHED

BREAKDOWN OF ROAD CROSSING COSTS

ROAD CROSSING	DESIGN SECTION	ROAD WIDTH (FEET)	BRIDGE LENGTH (FEET)	ROAD CROSSING COST
WEST HAWKINS	RA-1B **	66	103	\$0.00
McCANN RD	RA-1B	66	103	\$285,120.00
PLIER PRECISE	RA-4	66	101	\$279,640.00
McCANN RD	RA-7	66	46	\$134,840.00
TOTAL COSTS=				\$699,600.00

* TOTAL COSTS OF EACH WATERSHED INCLUDES BRIDGE COST PLUS 20% CONTINGENCY AND ENGINEERING FEE
** PREVIOUSLY FUNDED

NOTES:

- 1) TYPE = CHANNEL MATERIAL, WHERE: 1- CONCRETE, 2- GRASS/CONCRETE, 3- GRASS, 4- NO IMPROVEMENT
- 2) CY/LF = CUBIC YARDS/LINEAR FOOT
- 3) SF/LF = SQUARE FEET/LINEAR FOOT

TABLE C-16
CHANNEL QUANTITY AND COST CALCULATIONS
SCHOOL BRANCH/DRAIN 3 WATERSHED

WATERSHED	TYPE	LENGTH (FEET)	BOTTOM WIDTH (FEET)	DEPTH (FEET)	NUMBER DROPS	UNIT CONC. (CY/LF)	UNIT SEEDING (SF/LF)	EXCAVATION (CY)	DROP CONC. (CY)	CHANNEL CONC. (CY)	TOTAL SEEDING (SF)	COST CONC.	COST SEEDING	COST CUT/FILL	COST TOTAL
SCHOOL BRANCH															
SB-1A	4	0	0	0.00	0	0.00	0.00	0	0	0.00	0	\$0.00	\$0.00	\$0.00	\$0.00
SB-1A,1B	2	3000	45	8.00	2	1.04	25.30	33080	315	3130.95	75895	\$1,033,785.00	\$5,902.92	\$132,240.00	\$1,171,927.92
SB-1B	2	600	40	8.00	0	0.95	25.30	8740	0	570.48	15179	\$171,144.00	\$1,180.58	\$34,900.00	\$207,284.58
SB-2	3	3489	30	8.00	1	0.00	80.00	86910	180	0.00	277520	\$54,000.00	\$21,584.89	\$347,840.00	\$423,224.89
SB-2	3	1900	25	7.80	1	0.00	73.75	9940	150	0.00	140125	\$45,000.00	\$10,898.81	\$39,780.00	\$95,658.81
SB-2	3	4319	15	7.80	1	0.00	82.50	15270	90	0.00	269938	\$27,000.00	\$20,995.14	\$81,080.00	\$109,075.14
* TOTAL COSTS =												\$1,330,929.00	\$80,562.14	\$815,680.00	\$3,048,145.37

DRAIN 3															
DR3-1	3	1620	30	7.80	0	0.00	78.75	15620	0	0.00	127575	\$0.00	\$9,922.50	\$62,480.00	\$72,402.50
DR3-1	3	1758	30	8.10	0	0.00	80.83	13530	0	0.00	141739	\$0.00	\$11,024.13	\$54,120.00	\$65,144.13
DR3-1	3	1187	20	7.20	0	0.00	65.00	8220	0	0.00	75855	\$0.00	\$5,899.83	\$24,880.00	\$30,779.83
DR3-1	3	2788	10	6.40	4	0.00	50.00	21400	240	0.00	139400	\$72,000.00	\$10,842.22	\$85,800.00	\$168,442.22
* TOTAL COSTS =												\$72,000.00	\$37,688.68	\$227,080.00	\$1,115,734.42

TRIBUTARY INFORMATION

WATERSHED	TYPE	LENGTH (FEET)	BOTTOM WIDTH (FEET)	DEPTH (FEET)	NUMBER DROPS	UNIT CONC. (CY/LF)	UNIT SEEDING (SF/LF)	EXCAVATION (CY)	DROP CONC. (CY)	CHANNEL CONC. (CY)	TOTAL SEEDING (SF)	COST CONC.	COST SEEDING	COST CUT/FILL	COST TOTAL
SB(T)-1	3	440	10	3.32	2	0.00	30.75	359	120	0.00	13530	\$38,000.00	\$1,052.33	\$1,438.00	\$38,488.33
	3	380	5	4.00	0	0.00	30.00	293	0	0.00	10800	\$0.00	\$840.00	\$1,172.00	\$2,012.00
	3	250	5	3.80	1	0.00	28.75	204	30	0.00	7188	\$9,000.00	\$559.03	\$816.00	\$10,375.03
* TOTAL COSTS =												\$45,000.00	\$2,451.36	\$3,424.00	\$81,050.43

TOTAL WATERSHED COST \$4,224,930.22

BREAKDOWN OF ROAD CROSSING COSTS

ROAD CROSSING	DESIGN SECTION	ROAD WIDTH (FEET)	BRIDGE LENGTH (FEET)	ROAD CROSSING COST
OAK FOREST	SB-1A	33	77	\$84,710.00
HAWKINS PKWY	SB-2	66	78	\$219,120.00
BILL OWENS PKWY	SB-2	66	78	\$219,120.00
TOTAL COSTS =				\$532,950.00
BILL OWENS PKWY	DR3-1	66	77	\$218,480.00
CRENSHAW		33	79	\$97,020.00
HAWKINS		33	83	\$78,540.00
YATES		33	83	\$78,540.00
SPRING VALLEY		33	48	\$81,215.00
BIRDWELL LN		33	48	\$81,215.00
TOTAL COSTS =				\$893,010.00

* TOTAL COSTS OF EACH WATERSHED INCLUDES BRIDGE COST PLUS 20% CONTINGENCY AND ENGINEERING FEE

NOTES:

- 1) TYPE = CHANNEL MATERIAL, WHERE: 1-CONCRETE, 2-GRASS/CONCRETE, 3-GRASS, 4-NO IMPROVEMENT
- 2) CY/LF = CUBIC YARDS/LINEAR FOOT
- 3) SF/LF = SQUARE FEET/LINEAR FOOT

TABLE C-17
CHANNEL QUANTITY AND COST CALCULATIONS
WADE CREEK WATERSHED

WATERSHED	TYPE	LENGTH (FEET)	BOTTOM WIDTH (FEET)	DEPTH (FEET)	NUMBER DROPS	UNIT CONC. (CY/LF)	UNIT SEEDING (SF/LF)	EXCAVATION (CY)	DROP CONC. (CY)	CHANNEL CONC. (CY)	TOTAL SEEDING (SF)	COST CONC.	COST SEEDING	COST CUT/FILL	COST TOTAL
WADE CREEK															
WD-1	1	3475	35	11.50	0	1.25	0.00	7600	0	4338.83	0	\$1,300,987.88	\$0.00	\$30,400.00	\$1,331,387.88
WD-1	1	1080	50	8.30	0	1.38	0.00	17200	0	1488.91	0	\$440,872.40	\$0.00	\$88,800.00	\$509,472.40
WD-2	3	1585	50	10.00	0	0.00	112.50	36800	0	0.00	176083	\$0.00	\$13,893.75	\$147,200.00	\$180,893.75
WD-2	4	0	0	0.00	0	0.00	0.00	0	0	0.00	0	\$0.00	\$0.00	\$0.00	\$0.00
WD-2	3	1220	35	10.70	0	0.00	101.88	31800	0	0.00	124288	\$0.00	\$9,888.81	\$127,200.00	\$138,888.81
WD-2	1	1295	40	7.70	2	1.14	0.00	11300	280	1480.44	0	\$522,133.20	\$0.00	\$45,200.00	\$567,333.20
WD-3	1	930	40	6.00	1	1.05	0.00	8200	130	980.98	0	\$333,289.20	\$0.00	\$24,800.00	\$358,089.20
WD-3	1	550	40	4.80	1	0.99	0.00	4100	130	545.82	0	\$202,748.00	\$0.00	\$18,400.00	\$219,148.00
WD-3	1	930	30	5.10	1	0.82	0.00	5500	97.5	784.74	0	\$258,871.70	\$0.00	\$22,000.00	\$280,871.70
WD-3	1	1185	30	4.50	1	0.79	0.00	8900	97.5	837.45	0	\$310,486.05	\$0.00	\$27,800.00	\$338,086.05
WD-3	1	895	30	3.80	1	0.75	0.00	3500	97.5	675.48	0	\$231,888.95	\$0.00	\$14,000.00	\$245,888.95
WD-3	1	725	30	3.00	1	0.71	0.00	3200	97.5	517.00	0	\$184,349.25	\$0.00	\$12,800.00	\$197,149.25
WD-3	2	1515	40	2.50	0	0.81	7.91	16100	0	1223.82	11977	\$387,145.10	\$931.55	\$64,400.00	\$432,476.65
WD-3	3	895	15	6.00	1	0.00	52.50	700	90	0.00	38488	\$27,000.00	\$2,837.92	\$2,800.00	\$32,637.92
* TOTAL COSTS =												\$4,179,387.73	\$27,130.03	\$803,800.00	\$7,313,745.30
TRIBUTARY INFORMATION															
WATERSHED	TYPE	LENGTH (FEET)	BOTTOM WIDTH (FEET)	DEPTH (FEET)	NUMBER DROPS	UNIT CONC. (CY/LF)	UNIT SEEDING (SF/LF)	EXCAVATION (CY)	DROP CONC. (CY)	CHANNEL CONC. (CY)	TOTAL SEEDING (SF)	COST CONC.	COST SEEDING	COST CUT/FILL	COST TOTAL
WD(T)-1	2	330	10	6.38	0	0.35	20.11	224	0	115.85	8837	\$34,754.94	\$518.21	\$898.00	\$36,167.15
	2	1870	10	5.97	4	0.34	18.88	2273	140	837.52	35303	\$233,258.12	\$2,745.82	\$9,092.00	\$245,093.94
	2	1545	10	5.22	4	0.32	18.51	1947	140	498.59	25503	\$190,978.17	\$1,983.80	\$7,788.00	\$200,749.77
* TOTAL COSTS =												\$458,989.23	\$5,245.83	\$17,778.00	\$719,587.03
WD(T)-2	2	750	30	4.63	1	0.88	14.64	1583	105	508.11	10981	\$183,933.00	\$854.08	\$6,332.00	\$191,119.08
	1	1050	20	6.70	2	0.72	0.00	2024	130	755.79	0	\$285,737.00	\$0.00	\$8,098.00	\$273,833.00
	2	515	15	6.48	1	0.45	20.49	784	52.5	230.22	10553	\$84,816.14	\$820.80	\$3,056.00	\$88,692.94
	2	843	15	6.48	0	0.45	20.49	1225	0	378.85	17274	\$113,053.89	\$1,343.58	\$4,900.00	\$119,297.45
	3	1517	10	5.94	5	0.00	47.13	2135	300	0.00	71489	\$90,000.00	\$5,580.23	\$8,540.00	\$104,100.23
* TOTAL COSTS =												\$737,540.02	\$8,578.67	\$30,924.00	\$1,396,365.23
TOTAL WATERSHED COST															
TOTAL COSTS =												\$5,375,896.98	\$40,954.32	\$852,300.00	\$9,429,897.58

C-31

TABLE C-17
CHANNEL QUANTITY AND COST CALCULATIONS
WADE CREEK WATERSHED

BREAKDOWN ON ROAD CROSSING COSTS

ROAD CROSSING	SECTION SECTION	ROAD WIDTH (FEET)	BRIDGE LENGTH (FEET)	ROAD CROSSING COST
GARFIELD	WD-1	NI	NI	\$0.00
RR CROSSING	WD-2	NI	NI	\$0.00
HIGH STREET	WD-2	88	99	\$274,580.00
FREDONIA	WD-2	33	55	\$89,300.00
GREEN ST	WD-3	88	52	\$150,480.00
KING ST	WD-3	33	50	\$63,525.00
HOUSTON ST	WD-3	33	40	\$51,975.00
ELECTRA ST	WD-3	33	40	\$51,975.00
MOBBERLY AVE	WD-3	88	39	\$118,180.00
SYLVAN DR	WD-3	33	39	\$50,820.00
DAVIS ST	WD-3	33	39	\$50,820.00
TIMPSON ST	WD-3	33	38	\$49,885.00
NINTH ST	WD-3	33	38	\$49,885.00
ODEN ST	WD-3	33	38	\$49,885.00
COTTON ST	WD-3	88	38	\$108,240.00
PACIFIC RR CROSS	WD-3	NI	NI	\$0.00
WHALEY ST	WD-3	88	51	\$147,840.00
TOTAL COSTS=				\$1,284,890.00
RR CROSSING	WD(T)-1	NI	NI	\$0.00
HIGH ST		88	28	\$81,840.00
FREDONIA		33	28	\$35,805.00
TOTAL COSTS=				\$117,845.00
TIMPSON ST	WD(T)-2	33	44	\$58,595.00
PACIFIC RR		NI	NI	\$0.00
NELSON		33	44	\$58,595.00
SECOND ST		33	29	\$39,270.00
COLLEGE AVE		33	29	\$39,270.00
COTTON ST		88	38	\$108,240.00
SAN JACINTO		33	38	\$47,385.00
THIRD ST		33	29	\$39,270.00
TOTAL COSTS=				\$388,595.00

* TOTAL COSTS OF EACH WATERSHED INCLUDES BRIDGE COST PLUS 20% CONTINGENCY AND ENGINEERING FEE

NOTES:

- 1) TYPE = CHANNEL MATERIAL, WHERE: 1-CONCRETE, 2-GRASS/CONCRETE, 3-GRASS, 4-NO IMPROVEMENT
- 2) CY/LF = CUBIC YARDS/LINEAR FOOT
- 3) SF/LF = SQUARE FEET/LINEAR FOOT
- 4) NI = NO IMPROVEMENTS

APPENDIX D

Determination of Small Problem Area Design Solutions

Note: In order to compile and analyze appropriate information as well as report findings concerning the small problem areas, the list of problems/complaints on file at the City of Longview as of May 1990 was utilized. Problems brought to the City's attention after May 1990 will be analyzed by City staff using the same criteria as discussed herein and will be included in future study updates.

APPENDIX D
SMALL PROBLEM AREA
SUMMARY OF COSTS PER WATERSHED

Watershed	Total Cost
Coushatta Hills	\$ 100,100
Drain No. 2	49,600
Eastman Lake (Includes Longview Hts.)	815,900
Gilmer	318,230
Upper Grace	12,700
Middle Grace	247,100
Lower Grace	1,261,700
Guthrie	2,097,200
Upper Harris	407,440
Lower Harris	339,300
Iron Bridge	1,845,400
Johnson	73,000
LaFamo	193,300
Oakland	300
Ray/Elm	15,200
School	266,800
Wade	<u>787,700</u>
GRAND TOTAL	\$8,830,970

APPENDIX D

DETERMINATION OF SMALL PROBLEM AREA DESIGN SOLUTIONS

The steps taken by EH&A in the process of identifying, preliminarily designing and prioritizing solutions for flood drainage problems at locations where the contributing drainage area is less than 100 acres is provided herein. The development of solutions for problems in the less-than-100-acre areas is an undertaking separate from the formal drainage improvement evaluation and design to be carried out in the major creeks. It is pointed out here that all designs are preliminary and/or conceptual. A final design will be required in all instances prior to construction, and a final judgement on the potential impact on downstream areas must be made at that time.

The design process for the small drainage problem areas proceeded as follows:

1. Problem Area Identification - EH&A received from the City of Longview a computer printout listing all drainage-related citizen complaints. These were categorized by City staff into several types including:
 - A. Proposed CIP projects already evaluated and designed by City staff.
 - B. Proposed CIP projects not yet designed.
 - C. Projects, completed or otherwise, with a City issued work order.
 - D. Lot-to-lot problems that would likely be most-appropriately handled by affected parties.

Among these, EH&A evaluated and designed solutions for Item B projects. Solutions for Item A projects (planned CIP work already evaluated and designed by City staff) were obtained from City staff, reviewed and updated (where required) and included in our analysis.

City topographic maps at a scale of 1"=200' were grouped and combined such that each of the major drainage basins were separately covered. The locations of all small basin planned CIP projects were plotted on the appropriate (grouped) watershed maps. In addition, all channels draining more than 100 acres (the formal study reaches) were delineated.

2. **Site Inspection** - In many cases, it was determined that a proper preliminary drainage design could not be completed without a site inspection. Accordingly, after consultation with City of Longview staff, sites requiring a visual inspection were identified and visited, in most cases with a City of Longview staff member present.
3. **Problem Solution Design Methods** - At the direction of City of Longview staff, all small problem area drainage design and related cost estimating efforts carried out in this project are to be considered preliminary in nature. The purpose is to aid in the evaluation and prioritization of planned CIP projects, to provide a basic understanding of the type and magnitude of drainage problem present, and to take a "first cut" at assessing the probable cost and character of the best design solution. A final design effort will be required for each proposed improvement in the future.

The preliminary drainage design procedures employed to develop solutions generally involve the following standard techniques:

- A. **Determination of Peak Flows** - The "rational formula" was employed to determine peak flows. This technique includes estimation of time of concentration including travel time during both overland and channelized flow, evaluation of the 100-year rainfall intensity for a storm duration equal to the time of concentration, and specification of a fully-developed condition C factor (0.65-0.70 in virtually all cases).
- B. **Determination of Pipe and Roadside Ditch Capacity and Required Capacity** - In all cases, pipe and ditch capacities were determined based upon evaluation of "normal depth" (the depth and velocity of flow as predicted by Manning's Equation).

- C. **Determination of Culvert Capacity** - In all cases, culvert capacity was determined assuming inlet control at the structure and utilizing Texas Highway Department nomographs for the appropriate structure configuration.
 - D. **Inlet Capacity** - At the direction of the City of Longview staff, the inlet capacity for a standard inlet on grade was assumed to be 4 cfs and the inlet capacity for a standard inlet at a low point was assumed to be 6 cfs. In areas where significant inflow capacity was required, four-way sump inlets were employed and sized using the standard weir equation.
4. **General Design Procedures** - The following general design guidelines were followed during the drainage design procedure:
- A. In areas where an inlet was significantly undersized, additional inlets were not concentrated near the existing inlet but were distributed along the street upslope of the existing inlet.
 - B. In all cases, drainage structures were designed to accommodate the 100-year storm event.
 - C. In virtually all cases, the C-factor assumed to represent fully-built out conditions was 0.65-0.70. The C-factor was appropriately increased to represent existing conditions when conditions warranted.
 - D. 100-year rainfall intensities for varying storm durations were determined from National Weather Service publications Hydro-35 and TP-40 as provided in the proposed Drainage Criteria Manual.
5. **Development of Preliminary Cost Estimates** - To aid in the process of prioritizing drainage improvements, preliminary cost estimates were developed for all drainage

ESPEY, HUSTON & ASSOCIATES, INC.

design projects. The following items were costed based upon best estimates of the required quantities:

<u>Design Element</u>	<u>Cost</u>
1. Excavation for roadside ditches	\$10/yd ³
2. Excavation for larger-scale channel improvements	\$5/yd ³
3. Reinforced concrete storm sewer pipe	See Table D-1
4. RCP culverts	See Table D-1
5. Reinforced concrete box culverts	\$400/yd ³
6. Curb and gutter roadway (including drainage, contingency, and engineering)	\$100/lf
7. Curb alone	\$8/lf
8. Inlets	See Table D-1
9. Junction boxes	See Table D-1
10. Bagwall channel lining (R-Rap, for example)	See Table D-1
11. Revegetation	\$0.50/S.F.
12. Concrete channel lining	See Table D-1
13. Contingency	20 percent
14. Engineering	12 percent

Table D-1, presenting standard costs, was provided by the City to EH&A and is attached.

6. Summary of Results - Results of the small area analysis is presented in Table D-2.

TABLE D-1

LONGVIEW COSTRUCTION COSTS

(All Prices are Installed Costs, Material and Labor)

2" HMAC on 8" Base	\$10/SY
1.5" HMAC on 6" Base	\$7.50/SY
Curb and Gutter	\$6.00/LF
Junction Box	\$1200
Single Inlet	\$1200
Double Inlet	\$1800
Triple Inlet	\$2200
Quad Inlet	\$2400
4-Way Area Drain	\$1600
18" RCP	\$25/LF
24" RCP	\$30/LF
30" RCP	\$40/LF
36" RCP	\$50/LF
42" RCP	\$60/LF
48" RCP	\$70/LF
54" RCP	\$80/LF
60" RCP	\$110/LF
72" RCP	\$150/LF
84" RCP	\$180/LF
Headwall for 18" Pipe	\$450
Headwall for 24" Pipe	\$600
Headwall for 30" Pipe	\$800
Headwall for 36" Pipe	\$1100
Headwall for 42" Pipe	\$1300
Headwall for 48" Pipe	\$1500
Headwall for 54" Pipe	\$1800
Headwall for 60" Pipe	\$2200
General Excavation	\$4/CY
Monoslab Pavers	\$5/SF
Concrete Channel Lining	\$300/CY
R-Rap Lining	\$15/SF
Seeding with Bermuda (Hydromulch, watering and care)	\$0.70/SY

NOTE: Obtained from the City of Longview

TABLE D-2

SUMMARY OF DRAINAGE IMPROVEMENT REQUIREMENTS IN
DRAINAGE AREAS OF LESS THAN 100 ACRES

Location Code	Location	GIS Sheet No.	Priority ^{a)}	Description	Design Elements		Cost
<u>COUSHATTA HILLS</u>							
CHS-1	Sioux Court	146	C1	Repair street in cul-de-sac with French drain	French drain (6") French drain (8")	390 If 90 If	27,200
CHS-2	Coushatta Court	146	C1	Repair street in cul-de-sac with French drain	French drain (6") French drain (8")	390 If 90 If	27,200
CHS-3	1007 Delwood	146	A2	Add inlets and storm sewer to collect local drainage	Double inlets 24" RCP 18" RCP	5 500 If 400 If	45,700
						Total Cost =	\$ 100,100
<u>DRAIN 2</u>							
DN2-1	Tallwood Drive	111	B1	Install storm sewer drainage system	CIP (DR189038) ^{b)}		48,100
DN2-2	Kennedy Trail	94	C1	Install drainage swales between trailers	Drainage swale	200 If	1,500
						Total Cost =	\$ 49,600
<u>EASTMAN LAKE</u> (Includes Longview Heights)							
ELC-1	Wylie Circle	249	A1	Install 2-24" RCP storm sewers and 2 double curb inlets	24" RCP 2 double curb inlets 2 headwalls	300 If	12,300
ELC-2	1312 Booker	231	C1	Install curb and gutter	Curb and gutter Adjust driveways	2,000 If	22,000
ELC-3	Brooks St.	231	C1	Install curb, gutter and storm sewer	CIP (DR189033)		61,000
ELC-4	Lilly St.	249	B2	Construct lined ditch	CIP (DR189061)		121,000
ELC-5	El Paso St.	215	B2	Construct ditch improvements	CIP (DR189020)		297,000

TABLE D-2 (Cont'd)

Location Code	Location	GIS Sheet No.	Priority ^{a)}	Description	Design Elements	Cost	
ELC-6	Industrial Dr.	199	C1	Install 21", 27" and 30" RCPs and curb inlets	21" RCP 27" RCP 30" RCP Single inlet Double inlet Triple inlet Street repair	80 lf 20 lf 210 lf 2 3 1 80 sy	21,000
ELC-7	511 Delia	182	C2	Excavate roadside ditch, install 48"	Excavation	900 cy	10,800
ELC-8	600 Delia		C2	RCP and excavate outfall ditch	48" RCP	60 lf	
ELC-9	604 Delia		C2		Headwall	2 ea	
ELC-10	610 Grove Court	182	C1	Excavate roadside ditch, install 18" RCP driveway culverts and adjust driveways	Excavation 18" RCP	190 cy 45 lf	3,900
ELC-11	3000 Mona	182	B1	Excavate roadside ditch	Excavation	190 cy	800
ELC-12	Delia at Cedar Hill	182	C1	Excavate roadside ditch	Excavation	140 cy	600
ELC-13	508 Leota	181	C2	Install 3-60" RCP culverts at Pinebrook and excavate downstream channel street repair	60" RCP Excavation	150 lf	23,400
ELC-14	614 Harrell	180	C1	Excavate roadside ditches	Excavation	790 cy	3,200
ELC-15	724 Arkansas	180	C1	Excavate roadside ditches	Excavation	140 cy	600
ELC-16	2039 Leona	180	C1	Excavate roadside ditches	Excavation	510 cy	2,000
ELC-17	101 Dossey 207 Ann 307 Ann 310 Ann 313 Ann	181	B1	Construct concrete-lined ditch	CIP (DRI89013)		225,000
ELC-18	1402 Garner	163	C2	Install 54" RCP and cleanout ditch	54" RCP	50 lf	11,300
ELC-19	1305 Garner	163	A1		Headwall Excavation	2 ea	
						Total Cost =	\$ 815,900

D-7

TABLE D-2 (Cont'd)

Location Code	Location	GIS Sheet No.	Priority ^{a)}	Description	Design Elements	Cost
<u>GILMER</u>						
GIL-1	Between Northwest Drive and Woodvine 110 Wildwood 1810 Northwest	160	B2	Replace existing storm sewer system	CIP (DRI89077)	209,300
GIL-2	1704 Crestview	160	A1	Install curb along east side of Springdale	Curb 350 lf	3,800
GIL-3	Along south side of Evergreen	142	B2	Install storm sewer collection system in open ditch	CIP (DRI89027) 550 lf 1	46,800
GIL-4	2113 Balsam	143	A1	Install additional inlets and storm sewer	36" RCP 250 lf 24" RCP 800 lf Inlets 6	58,330
Total Cost =						\$ 318,230
<u>UPPER GRACE</u>						
UGR-1	Gilmer Road at Gregtex Road	73	A2	Replace existing RCP culvert with box culvert	Box culvert	12,700
Total Cost =						\$ 12,700
<u>MIDDLE GRACE</u>						
MGR-1	Choctaw Street	145	C1	Provide storm sewer collection system	CIP (DRI89051)	160,800
MGR-2	Cynthia Street	144	C1	Improve existing stormwater collection system by addition of curb inlets	CIP (DRI89018)	9,700
MGR-4	Stanford Drive	178	B1	Extend storm sewer pipe across residential lot	CIP (DRI89037)	11,000
MGR-5	2512 Balsam	143	C1	Provide additional storm sewer and inlet	24" RCP 200 lf Inlet 1 Junction boxes 2	13,700

TABLE D-2 (Cont'd)

Location Code	Location	GIS Sheet No.	Priority ^{a)}	Description	Design Elements		Cost
MGR-6	2811 Clendenen 2901 Clendenen 611 Hampshire 606 Richfield 610 Richfield	144	A1	Provide additional four-way inlets and storm sewer	Four-way inlets 48" RCP	4 400 lf	51,900
						Total Cost =	\$ 247,100
<u>LOWER GRACE</u>							
LGR-1	2710 Estes Parkway	265	A1	Improve roadside ditches and storm sewer	Roadside ditches 48" RCP	1,500 lf 730 lf	92,300
LGR-2	1806 Hoffman	230/247	C2	Improve roadside ditch and install culvert	Roadside ditch Culvert Driveway culverts	650 lf 1 5	9,500
LGR-3	240 E. Highland	230	A2	Provide roadside ditch improvements	Roadside ditch Driveway culverts	650 lf 25	62,800
LGR-4	212 E. Culver	230	A2	Improve roadside ditch	Roadside ditch Driveway culverts	350 lf 8	10,800
LGR-5	Clingman Street	247	B1	Provide concrete-lined ditch and storm sewer improvement (extend thru Budd Pl.)	CIP (DRI89070)		83,800
LGR-6	Flanagan Street	230	C1	Provide curb and gutter drainage on street	Curb and gutter street	500 lf	50,000
LGR-7	1606 Flanagan	230	B2	Install storm sewer in ditch	CIP (DRI89040)		59,400
LGR-8	513 N. Jean	247	A1	Provide inlets and storm sewer	36" RCP Inlets	220 lf 4	27,400
LGR-9	108 Brown	196	B2	Add major storm sewer line and improve neighborhood storm sewer system	48" RCP 24" RCP Inlets Junction boxes	650 lf 4,000 lf 26 30	421,000
LGR-10	227 Harrison	213	A1	Improve channel and culvert capacities	Concrete-lined channel Box culverts	1,700 lf 3	350,600

TABLE D-2 (Cont'd)

Location Code	Location	GIS Sheet No.	Priority ^{a)}	Description	Design Elements	Cost	
LGR-11	210 W. Morris	230	A2	Improve culverts and provide channel improvements	Culvert Box culvert Bagwall	1 1 720 lf	36,200
LGR-12	107 Richardson	230	C1	Improve roadside ditch	Roadside ditch Driveway culverts	250 lf 2	2,700
LGR-13	Willow Drive	247	B2	Provide increased storm sewer capacity (after LGR-5)	CIP (DRI89028)		43,800
LGR-14	Virginia Street	247	A1	Replace existing drainage structure	CIP (DRI89007)		11,400
						Total Cost =	\$1,261,700
<u>GUTHRIE</u>							
GUT-1	Baylor at McCann	178	A2	Improve culvert under Baylor and channel downstream	4' x 8' box culvert channel lining	1 34 cy	27,400
GUT-2	1402 Bluebird	180	A1	Provide four 48" RCP's beginning behind house to carry flows beneath intersection	48" RCP Junction Box	480 lf	58,700
GUT-3	1204 School Drive	179	A1	Improve ditch between houses, along School Drive and across school property	Concrete erosion protection Driveway culverts Roadside ditch Improved channel	4 cy 2 140 lf 1,280 lf	29,200
GUT-4	1000 McCann	196	C1	Place diversion bump across driveway then provide roadside ditch down McCann to creek	Roadside ditch Culvert Diversion bump	850 lf 1 1	6,700
GUT-5	3 New Forest	163	C1	Provide additional inlets on New Forest	Inlets 24" RCP 36" RCP	5 400 lf 150 lf	41,000
GUT-6	1206 N. Ninth and 1211 N. Tenth	180	A2	Provide roadside ditches. Consider doing GUT-13 at same time to avoid increasing problem there.	Roadside ditch Driveway culverts Culvert	1,760 lf 24 1	27,400
GUT-7	1404 N. Ninth	180	A2	Provide improved roadside ditches and culverts. Consider doing GUT-13 at same time to avoid increasing problem there.	Road repair Driveway culverts Roadside ditch Culverts	40 lf 44 4,200 4	110,400

D-10

TABLE D-2 (Cont'd)

Location Code	Location	GIS Sheet No.	Priority ⁽¹⁾	Description	Design Elements	Cost
GUT-8	2129 Tryon	163	C1	Cut and pave swale across driveway	Driveway paving	500
GUT-9	Groveland Street, 403 Glenhaven	179	B1	Replace open ditch with improved lined ditch	CIP (DRI89058)	119,600
GUT-10	100-117 Rawley	180	C2	Install curb and gutter street and additional storm sewer	Curb and gutter street 24" RCP	1,100 If 400 If 126,000
GUT-11	809 Jefferson	179	C1	Provide roadside ditch and driveway culverts	Roadside ditch Driveway culverts	300 If 4 4,000
GUT-12	1502 McCann	178	C1	Provide hump at driveway entrance	Asphalt/concrete	300
GUT-13	North 7th Street	163	C1	Install storm sewer and inlet collection system in open ditch	CIP (DRI89015)	43,200
GUT-14	Hillcrest Drive	179	A2	Extend existing storm sewer collection system; provide stormwater outfall	CIP (DRI89055)	28,300
GUT-15	Hoyt Drive	162	B1	Replace large open ditch with improved, lined ditch	CIP (DRI89047)	16,800
GUT-16	Willow Oak Drive	179	A1	Improve existing storm sewer collection system	CIP (DRI89060)	24,000
GUT-17	Glen Haven Drive	179	B1	Construct catch basins and storm sewer along Glen Haven and across Willow Creek	CIP (DRI89008)	24,000
GUT-18	Clark Street	196	C1	Provide curb and gutter street along Clark Street	CIP (DRI89044)	85,000
GUT-19	Gates Street	196	C1	Provide grading to establish roadside ditches, reduce street grade to provide positive drainage off lots	CIP (DRI89057)	51,500
GUT-20	Montclair Street	162	B2	Install storm sewer collection system in open ditch	CIP (DRI89026)	154,500
GUT-21	4 Bunker Hill	178	C1	Provide additional inlets along Fox Lane	24" RCP Junction box Double inlets	400 If 1 5 29,800

D-11

TABLE D-2 (Cont'd)

Location Code	Location	GIS Sheet No.	Priority ^{a)}	Description	Design Elements		Cost
GUT-22	Eden at Long Park	163	C1	Close curb cut, install inlet and storm sewer system	24" RCP Double inlet	70 1	7,200
GUT-23	21-24 Marguerite	163	C1	Reroute existing 24" storm sewer	24" RCP Inlet	250 If 1	25,200
GUT-24	1305 Jonquil 603 Jonquil 1707 Tulip 1710 Tulip	163	A2	Install inlets, storm sewer, and concrete-lined channel	CIP (DRI89069)		1,056,500
Total Cost =							\$2,097,200
<u>UPPER HARRIS</u>							
UHA-1	308 E. Twilight	142	A2	Place storm sewer in ditch and improve culvert	48" RCP Box culvert Junction box	290 If 1 1	35,900
UHA-2	Dundee Road	125	A2	Construct storm sewer collection system	CIP (DRI89025)		50,100
UHA-3	Lynnwood Street	142	B1	Install curb and gutter	CIP (DRI89034)		12,300
UHA-4	Buckner Street	142	C1	Install storm sewer collection system	CIP (DRI89010)		50,700
UHA-5	Rainbow Drive 1708 Rainbow	159	B2	Replace open ditch with concrete pipe collection system (consider doing prior to, or at the same time as, UHA-10 to avoid increasing this problem)	CIP (DRI89035)		104,400
UHA-6	Loraine Court (500 block)	159	B1	Install storm sewer in open ditch	CIP (DRI89049)		17,400
UHA-7	Loraine Court (700 block)	159	B1	Install storm sewer in open ditch	CIP (DRI89009)		12,340
UHA-8	107 Dancer	159	A1	Improve roadside ditch and driveway culvert	Roadside ditch Driveway culverts	1,000 If 7	13,800
UHA-9	2018A Secretariat	142	A2	Provide enhanced storm sewer and inlet capacity	30" RCP Inlets	600 If 5	44,400

D-12

TABLE D-2 (Cont'd)

Location Code	Location	GIS Sheet No.	Priority ^{a)}	Description	Design Elements		Cost
UHA-10	1806 Swan	159	A2	Provide enhanced storm sewer and inlet capacity (consider doing UHA-5 prior to, or at the same time as this to avoid increasing its problem)	24" RCP Inlets	900 If 4	46,000
UHA-11	Birch Drive	159	A1	Improve roadside ditches and culvert under Birch Drive	Roadside ditch Culvert	150 If 1	4,400
UHA-12	908 Fairmont	177	A1	Raise curb along south side Fairmont	Curb	850 If	9,100
UHA-13	905 W. Fairmont	177	A1	Increase inlet and pipe capacity	36" RCP Four-way inlet	36 If 1	6,600
						Total Cost =	\$ 407,440
LOWER HARRIS (includes areas to south)							
LHA-1	Ranier Street	193	B1	Replace open ditch with concrete storm sewer	CIP (DRI89045)		10,300
LHA-2	705 Stewart	193	A1	Provide drainage swales on either side of house	Drainage swale	360 If	2,900
LHA-3	910 Willow Springs Willow Springs Road	193	B1	Install storm sewer in drainage ditch	CIP (DRI89056)		40,300
LHA-4	Brandon Street	176	B1	Install concrete lining in unimproved earthen ditch (Berkley St. to Drain 4)	36" RCP Concrete-lined channel	40 If 750 If	55,000
LHA-5	Grand Avenue	176	A1	Construct new roadside ditches	CIP (DRI89016)		10,900
LHA-6	Avenue A	176	A2	Construct storm sewer, inlets and outfall (extend to LHA-4, do after LHA-4)	CIP (DRI89005)		107,000
LHA-7	613 Fairway 627 Fairway	176	B1	Install RCP in earthen ditch (may need to extend thru LHA-10)	54" RCP	260 If	26,200
LHA-8	Scenic at Broadway	176	A1	Extend culvert pipe and fill existing channel	24" RCP	15 If	2,700
LHA-9	601 Milligan 603 Milligan	176	C1	Install curb and gutter	Curb and gutter	300 If	3,200
LHA-10	712 Niblick	176	B2	Install storm sewer pipe in existing ditch (after LHA-11)	24" RCP Junction box	200 If 1	9,700

D-13

TABLE D-2 (Cont'd)

Location Code	Location	GIS Sheet No.	Priority ^{a)}	Description	Design Elements	Cost			
LHA-11	201 Birdie Place	176	B2	Install storm sewer and inlets (do after LHA-7)	36" RCP 4-way inlet Junction boxes	300 If 1 2 25,500			
LHA-12	1100 Memphis 1010 Memphis	194	C1	Improve roadside ditch drainage	Roadside ditch Driveway culverts	1,350 If 8 18,400			
LHA-13	Harroun Court	176	C1	Repair street in cul-de-sac with French drain	French drain (6") French drain (8")	390 If 90 If 27,200			
Total Cost =						\$ 339,300			
<u>IRON BRIDGE</u>									
IBC-1A	3104 LeTourneau	265	C1	Install 24" RCP and curb inlets	24" RCP single curb inlets headwall	270 If 2 1 11,100			
IBC-1B	719 Ethyl	265	C1	Install curb, gutter, 4 inlets, and 1,000 lf 18" RCP storm sewer	CIP (DRI89064)	37,000			
IBC-1C	708 Swancy	265	C1	Excavate roadside ditch on south side	Excavation	280 cy 1,100			
IBC-2	Bishop St.	265	B2	Replace earthen ditch w/concrete-lined ditch. Raise low water crossing	CIP (DRI89078)	244,000			
IBC-3	Melba St./Bobby St.	265	B2	Replace earthen ditch w/concrete-lined ditch	CIP (DRI89006)	103,000			
IBC-4	2508 Twelfth	214/231/248	B1	Install curb and gutter street; Twelfth St. from East Cotton St. to Ruth St.	CIP (DRI89066)	1,202,000			
IBC-5	2312 Twelfth		B1						
IBC-6	2303 Twelfth		B1						
IBC-7	2219 Twelfth		B1						
IBC-8	2217 Twelfth		B1						
IBC-9	1606 Twelfth		B1						
IBC-10	1508 Twelfth		B1						
IBC-11	1309, 1311 Twelfth		B1						
IBC-12	1300 Twelfth		B1						
IBC-13	1010 Twelfth		B1						
IBC-14	1115 Lemmons		248				C1	Install curb, gutter and storm sewer	177,000
IBC-15	1119 Lemmons		248				A1		
IBC-16	817, 824 Harmon		248				A2	Install 48" RCP	CIP (DRI89011) 13,000

D-14

TABLE D-2 (Cont'd)

Location Code	Location	GIS Sheet No.	Priority ¹⁾	Description	Design Elements		Cost
IBC-17	819 Aurel	231	B1	Install curb (both sides)	Curb	600 lf	3,600
IBC-18	812 Level	231	C2	Install 10' x 6' x 130 lf box culvert	Excavation Concrete Adjust existing structures	600 cy 105 cy	52,500
IBC-19	1001 Thirteenth	231	C1	Cleanout existing roadside ditches	Excavation	280 cy	1,100
IBC-20	912 Thirteenth	231	C1				
Total Cost =							\$1,845,400
<u>JOHNSON</u>							
JON-1	Live Oak Drive	162	A2	Install concrete storm sewer in open depth	CIP (DRI89067)		30,000
JON-2	Erskine Drive	162	A2	Install inlet and storm sewer	CIP (DRI89014)		28,700
JON-3	2306 Airline	145	B1	Provide lining drop into roadside ditch, clean driveway culvert	Lined drop Driveway culvert	10 lf 1	1,000
JON-4	203 Skyline	128	C1	Provide adequate roadside ditches and driveway culverts	Roadside ditch Driveway culverts	360 lf 3	8,800
JON-5	112 Clay	128	C1	Regrade roadside ditch	Roadside ditch	440 lf	4,500
Total Cost =							\$ 73,000
<u>LAFAMO</u>							
LAF-1	1005 Baxley	158	B1	Provide backfill and bagwall channel lining to prevent erosion near residential structure	Bagwall	2,320 sf	48,500
LAF-2	1203 Baxley	158	A1	Install storm sewer in ditch to Lafamo Creek	48" RCP Junction boxes	660 lf 4	80,400
LAF-3	1901 Silver Falls	158	C1	Clear and grub channel	Clearing and grubbing	800 lf	57,600

D-15

TABLE D-2 (Cont'd)

Location Code	Location	GIS Sheet No.	Priority ^{a)}	Description	Design Elements	Cost	
LAF-4	Stanolind	141	C1	Provide roadside ditch along Stanolind	Roadside ditch	1,100 lf 6,800	
						Total Cost =	\$ 193,300
<u>OAKLAND</u>							
OAK-1	1007 Coleman	163	A1	Provide higher breakover elevation at driveway entrance	asphalt/concrete	300	
						Total Cost =	\$ 300
<u>RAY/ELM</u>							
REL-1	110 Elm Creek	93	B1	Provide improved roadside ditches	Roadside ditch Driveway culverts	370 lf 2 15,200	
							\$ 15,200
<u>SCHOOL</u>							
SCH-1	Scarlett Acres	109	B2	Replace open ditch with storm sewer collection system	CIP (DRI89043)	38,300	
SCH-2	Ben Hogan Drive	126	A1	Install storm sewer and inlet collection system	CIP (DRI89041)	13,600	
SCH-3	Oaklawn Creek	143	A2	Provide stormwater collection system with storm sewer and catch basins	CIP (DRI89017)	111,200	
SCH-4	412 Wain 415 Wain 417 Wain	108	A1	Install adequately-sized storm sewer and inlets	24" RCP 36" RCP Junction box	200 200 1 36,000	
SCH-5	#4 Bellegrath	126	A1	Improve existing storm sewer system	24" RCP Inlets Junction boxes	1,000 lf 6 5 67,700	
						Total Cost =	\$ 266,800
<u>WADE</u>							
WAD-1	803 Stuckey	197	B1	Replace open ditch with concrete storm sewer system	CIP (DRI89030)	52,500	

D-16

TABLE D-2 (Concluded)

Location Code	Location	GIS Sheet No.	Priority ^{a)}	Description	Design Elements	Cost	
WAD-2	1005 Olive	197	A1	Improve 8th Street and provide storm sewer drain to 72" RCP at 1st Street	Improved C+G roadway 30" RCP	1,200 If 1,300 If	172,000
WAD-3	1401 Gay	214	A2	Provide additional storm sewer along Cotton and improve roadside ditches along Gay	36" RCP Inlets Roadside ditch	1,000 If 5 700 If	81,800
WAD-4	407 S. 13th	214	C1	Provide improved roadside ditch to low point at 12th and Sylvan	Roadside ditch Driveway culverts	900 If 9	7,800
WAD-5	Bivens Addition	197	A2	Install stormwater collection system including storm sewer, catch basins and outfalls	CIP (DRI89023)		247,800
WAD-6	Jewel Street 208 W. Jewell	230	B1	Replace open roadside ditch with storm sewer	CIP (DRI89042)		10,000
WAD-7	124 Hughes	213	A1	Provide pipe under driveway and down Hughes to creek	24" RCP Junction box	300 If 1	13,700
WAD-8	Flanagan Street (Garfield to Marion)	230/213	A2	Provide curb and gutter	Curb/gutter	1500 If	150,000
WAD-9	Second Street	213	B2	Instal culverts, concrete channel, street surface	CIP (DRI89032)		52,100
						Total Cost =	\$ 787,700
						GRAND TOTAL COST =	\$8,830,970

^{a)}Priority Classification

- A1 Home flooding or public safety problem. No anticipated adverse downstream impacts due to construction of improvements.
- B1 Erosion problem. No anticipated adverse downstream impacts due to construction of improvements.
- C1 Temporary nuisance drainage problem. No anticipated adverse downstream impacts due to construction of improvements.
- A2 Home flooding or public safety problem. Anticipated adverse downstream impacts due to construction of improvements.
- B2 Erosion problem. Anticipated adverse downstream impacts due to construction of improvements.
- C2 Temporary nuisance drainage problem. Anticipated adverse downstream impacts due to construction of improvements.

^{b)} City's Capital Improvement Project Number and Cost Estimate

ESPEY, HUSTON & ASSOCIATES, INC.

APPENDIX E

Overview of Funding Options

APPENDIX E
TABLE OF CONTENTS

<u>Section</u>		<u>Page</u>
E1.0	<u>PURPOSE</u>	E-1
E2.0	<u>OPTIONS</u>	E-1
	E2.1 GENERAL FUND	E-2
	E2.2 STORM DRAINAGE UTILITY SERVICE CHARGES	E-3
	E2.3 BONDS	E-4
	E2.4 IMPACT FEES	E-4
	E2.5 IN LIEU OF CONSTRUCTION FEES	E-5
	E2.6 SYSTEM DEVELOPMENT CHARGES	E-5
	E2.7 SPECIAL ASSESSMENT OR IMPROVEMENT DISTRICTS	E-6
	E2.8 PLAN REVIEW AND INSPECTION FEES	E-6
	E2.9 FEDERAL AND STATE FUNDING	E-7
E3.0	<u>EVALUATION CRITERIA</u>	E-7
	E3.1 COSTS	E-8
	E3.2 REVENUE CAPACITY	E-8
	E3.3 TIMING AND PROCESS FOR IMPLEMENTATION	E-9
	E3.4 FINANCIAL IMPACT	E-9
	E3.5 CONSISTENCE WITH PROGRAM NEEDS	E-10
	E3.6 EQUITY AND PUBLIC ACCEPTANCE	E-10
E4.0	<u>REVENUE CAPACITY</u>	E-11
	E4.1 GENERAL FUND	E-12
	E4.2 STORM DRAINAGE UTILITY SERVICE CHARGES	E-13
	E4.3 BOND ISSUES	E-15

APPENDIX E
OVERVIEW OF FUNDING OPTIONS

E1.0 PURPOSE

This section will identify and describe a number of options for providing revenues to implement the selected elements of the master drainage plan. The proposed criteria for evaluation of the options are identified and defined and will be used in a later section to determine the most feasible options for the City of Longview. This section will include an analysis of the revenue generation capacity of several of the options based on assumed units of fees or assessments.

The options are discussed separately, but a single method of generating funds will most likely not be capable of meeting the needs of an expanded and comprehensive stormwater management program. A combination of methods is generally necessary to generate sufficient funds for a comprehensive program, including major capital improvements to drainage systems and an adequate maintenance program. Historically, the availability of funds from the budget of a city's general fund has been limited to the highest priority and the most critical needs. Equity and consistency are other reasons for developing a combination of funding options.

E2.0 OPTIONS

There are a number of options used by local governments for funding stormwater management. The number of options has increased as more cities and counties look for methods to expand the base of financial support but also to localize the cost for some projects when appropriate.

These options include:

- appropriations from the general fund,
- storm drainage utility service charges,
- revenue and general obligation bonds,

ESPEY, HUSTON & ASSOCIATES, INC.

- impact fees,
- fees in lieu of construction,
- system development charges,
- special assessment or improvement districts,
- plan review and inspection fees, and
- federal and state funding

Only a few of the options have the revenue capacity to be a primary method of financing for a comprehensive stormwater management program. Primary funding methods are capable of financing major capital improvements and/or the overall operation and maintenance of a drainage program. The general fund, storm drainage utility service charges, and bond issues are considered primary methods.

Secondary methods provide a lesser level of frequency or shorter duration of funding and are designed to finance smaller projects with a specific service area or special services for a limited clientele. Secondary methods are also used to allow participation in regional facilities in lieu of individual on-site facilities and to provide recovery of costs for regional facilities as properties develop in the future.

E2.1 GENERAL FUND

The general fund is the primary fund for financing traditional municipal purposes and services, including police, fire, street and property maintenance, court systems, parks and recreation, planning, general administration, and social services. The usual sources of general fund revenues are property taxes; sales taxes; business, franchise and other miscellaneous taxes; fines; fees for services, licenses and permits; and other miscellaneous sources.

Taxes provide a large majority of revenues of the general fund for many cities in Texas. For the City of Longview, taxes were projected to provide 84% of general fund revenues for fiscal year 1990, including 41% from property taxes, 34% from sales taxes, and 9% from other business and occupational taxes.

Generally, the revenue sources for a general fund are based on property values, sales of products and services, and business income. These factors usually have little correlation with the level of benefit or service received from a stormwater management program.

E2.2 STORM DRAINAGE UTILITY SERVICE CHARGES

The stormwater utility is a relatively recent concept in municipal finance. Local governments are adopting the approach, historically used for water, wastewater, solid waste, and electric service, to create a separate program generally self-supported by charges to users of the system. For fifteen years or more, there has been a trend to move toward user charges for services previously funded with property taxes.

The authority for establishing a municipal drainage utility system is found in Chapter 402 of the Local Government Code.

A drainage service charge can be assessed against all properties in the jurisdiction. There are a number of methodologies for setting rates. All are based in some manner on the degree of benefit received from the program. The degree of benefit is represented by some relationship to the property's contribution to the drainage system. The contribution of stormwater in excess of natural conditions occurs when natural conditions are altered and impervious areas are increased. The factors used in the methodologies include gross area, slope, and intensity of development with varying emphasis and modifications to each.

The methodologies generally result in a rate structure which has a base unit or equivalent service unit, usually an average single-family residence with a defined area. A service charge is set for the base unit, and other types of property are assessed in multiples of the base fee. The multiples are calculated differently in the various methodologies, using the area and a run-off coefficient or extent of impervious area.

E2.3 BONDS

Revenue bonds and general obligation bonds are an option for financing large projects and major capital expenditures. The long-term debt provides up-front funding which is then repaid with interest over time.

Revenue bonds are backed by the revenue stream from user charges and possibly other secondary funding options. Generally, revenue bonds are feasible only after the revenue source is established and proven as stable, reliable, and sufficient. Revenue bonds generally include participation by tax-exempt properties.

General obligation bonds are backed by the full faith and credit of the issuer. This includes the pledge of an available and sufficient ad valorem tax authorized by the voters. Other revenues that are available may be used to reduce the amount from taxes. General obligation bonds are feasible to the extent of public acceptance and the overall debt capacity.

E2.4 IMPACT FEES

An impact fee is a secondary funding source which is designed to recover an appropriate share of the cost of capital improvements which are required to accommodate new development. The impact fee is assessed against new development projects.

Senate Bill 336 was passed by the 70th Texas Legislature in 1987 and specifies the process and requirements for development and adoption of an impact fee. The requirements generally include the adoption of a capital improvement plan, a definition of specific improvements based on impacts of new development, the estimated costs and calculation of the unit cost, a separate accounting for each project, the determination of an impact period, and provisions for return of unused funds.

The statute was intended to eliminate certain abuses such as excessive fees, impact fees used for upgrading existing facilities serving existing development, and impact fees used in other ways not related to the impact of new development.

The fee in lieu of construction and the system development charge could be interpreted to be within the definition of an impact fee. The specific implementation procedures of Senate Bill 336 would then be required for these methods.

E2.5 IN LIEU OF CONSTRUCTION FEES

A fee in lieu of construction is a secondary source of revenues. Its purpose is not for general funding requirements but for allowing new development to pay toward the cost of regional detention facilities instead of constructing an individual on-site detention facility. On-site detention of stormwater runoff from new development is commonly required in stormwater management plans. However, the proliferation of small and scattered on-site systems results in regulatory, operational and maintenance problems. Regional facilities could also be more economical and efficient.

However, sufficient revenues from another source must be available to construct regional facilities before all development in the service area occurs and the in-lieu fees are available. The in-lieu fees are then collected as development occurs and can repay the original source.

E2.6 SYSTEM DEVELOPMENT CHARGES

A system development charge is a secondary funding method used to balance funding of capital improvements more equitably. The system development charge is an attempt to ensure that properties developed before and after a major project is completed share appropriately in the cost.

The revenues are dependent on the rate of development. The original cost of the capital improvement must be funded with a primary source.

The system development charge is designed with consideration to the time of construction, time of development, cost of facilities, and relative capacity requirements. It is typically assessed as a lump sum at the time of development approvals.

E2.7 SPECIAL ASSESSMENT OR IMPROVEMENT DISTRICTS

A special assessment district can be a feasible secondary funding option for certain applications, particularly for smaller localized projects. Capital projects, special studies, and repairs and maintenance can be financed with a special assessment on the properties within the defined benefit area.

The benefit area for drainage projects is usually not as readily apparent to some property owners as for other types of linear projects like roads, curb and gutter improvements, water lines, and wastewater lines. In addition, the design of the assessment rate may not be as simple as one for a linear project which can be based on front footage, property area, and proximity to the project.

A special improvement district is another method of funding a special project with a defined benefit area. These include a drainage district created and operated pursuant to Chapter 56 of the Texas Water Code and a stormwater control district under Chapter 66 of the Texas Water Code. These districts generally have powers limited to construction of facilities and improvements for drainage and stormwater control purposes. The district can issue bonds supported by ad valorem taxes on all taxable property in the district. The confirmation of the district and the authorization for issuance of bonds and levy of a tax must be approved by the voters in the district.

E2.8 PLAN REVIEW AND INSPECTION FEES

Plan review and inspection fees are a common secondary source of revenue. The fees are designed to recover at least a portion of the cost of regulation and administration of private development projects. The review of plans, construction inspection, and periodic checks of maintenance of private projects are required to ensure compliance with standards and regulations.

These fees are set by ordinance and usually are related to the category and size of the project. They are typically assessed at the time of development approvals.

E2.9 FEDERAL AND STATE FUNDING

Federal funding assistance is not considered a likely or feasible source of funds for a comprehensive stormwater management program. State funding assistance may be possible for certain projects.

Federal funds have been available through the United States Corps of Engineers for flood control projects. Funds are limited and projects must undergo a lengthy feasibility analysis.

State funding has been available to some extent through the Texas Water Development Board. The Research and Planning Fund provides matching grant funds for flood protection planning. The amount of funds available is dependent on the annual appropriation for that purpose by the state.

The Water Development Fund has been eligible since November 1985 to make loans for flood control projects. The loans are made pursuant to an application process. The loans are available for structural and nonstructural purposes. Priority is given for projects which will alleviate existing flooding problems in developed areas rather than projects for allowing development of areas with flooding problems.

The State Water Pollution Control Revolving Fund has also recently been made eligible for providing loan assistance for nonpoint source pollution control projects.

E3.0 EVALUATION CRITERIA

The various funding options can be properly evaluated and compared with the use of consistent criteria, such as the following:

- costs of implementation and administration,
- revenue capacity,
- timing and process for implementation,
- financial impact on citizens and businesses,
- consistency with program needs, and
- equity and public acceptance.

E3.1 COSTS

The costs of development, implementation, and administration of various funding options will vary significantly. Some methods, especially existing sources or modifications thereof, could require minimal additional expense. Other new and innovative options can require significant front-end costs for planning, proper design of rate methodologies, legal assistance for adoption, and creation of billing, accounting and support systems. A method providing overall support for a program will generally require more administrative expense for a longer time than an option funding only a special purpose or small project.

Initial developmental and implementation costs of the various options need to be considered in conjunction with other criteria. Those which have greater revenue capacity and are most equitable may have higher front-end costs. However, an option which generates sufficient revenues in an equitable, timely and stable manner may have greater public acceptance and be more desirable than an option with lower costs. The front-end costs can also be controlled somewhat by the degree of flexibility and complexity incorporated into the rate design; i.e., "perfect equity" may not be cost-effective.

E3.2 REVENUE CAPACITY

The revenue capacity of a funding option is a major consideration in the evaluation of its feasibility. The options must be evaluated to determine the initial amount of funds generated, the frequency and timing of the revenues, the stability and long-term capacity of the revenue stream, and the sensitivity to economic conditions and other influences.

A single option is not likely to be feasible by itself in providing sufficient revenues for all elements of a comprehensive stormwater management program in an equitable manner. The capacity of an option for providing revenues for capital improvements and/or continuing operation and maintenance of the drainage system will determine whether it can be a primary or secondary funding method in the optimal combination of options.

E3.3 TIMING AND PROCESS FOR IMPLEMENTATION

The timing and process for implementation of funding options vary significantly just as the costs of implementation. Certain options, such as an existing source or one requiring only a modification of an existing source, can be implemented simply and almost immediately. Other new options may require extensive preparation, proper and orderly adoption of ordinances with public notice and hearings, technical development of rate methodologies, and then creation of the administrative system. The entire process could take over a year from inception to implementation.

The timing for implementation of a funding option is a critical path on the schedule for development of a comprehensive stormwater management program. Delays due to implementation of a funding source can increase project costs, especially for a critical repair or replacement project where a failure would be much more costly and present a danger to the public.

The process for implementation of several of the secondary funding options may be affected by Senate Bill 336, the Impact Fee Act, passed by the 70th Texas Legislature in 1987.

E3.4 FINANCIAL IMPACT

The financial impact of an option will be an important factor in the public acceptance of the funding method. A new or increased assessment on citizens and the business community must be reasonable and fairly allocated in order not to exceed the limits of the public's general willingness to pay for necessary services. The benefits of a drainage system are not as direct and universally perceived as those for water and wastewater systems. Therefore, a funding option will be feasible only if the financial impact is tolerable and related to some measure of benefit received.

The funding options allocate the costs of a stormwater management program at different levels for the various segments of the community. Some can be used to isolate the costs on a site-specific or direct-benefit basis. Other options can use a rate or fee designed to progressively distribute costs based on intensity of development, land area and type, or property value. Many of the options also include financial participation by tax-exempt properties.

E3.5 CONSISTENCY WITH PROGRAM NEEDS

The options must be evaluated in terms of consistency with the initial and future funding needs of the stormwater management program. The financial requirements will vary with the various stages and elements during the development of the program. Some options can provide a relatively stable and reliable revenue stream which is beneficial in planning the strategy and timing of drainage improvements. Funding options that are not based on consumption will provide more short-term and long-term stability than water and electric rate revenues which are affected by weather, seasons, conservation, and general economic conditions.

Other options may not provide a stable revenue stream but still could be consistent with the overall program by providing revenues directly related to specific services or projects as they are needed.

Timing, revenue capacity and equity are essential factors in a consistent financial strategy. The need for overall consistency is one reason that a combination of options is usually necessary for a comprehensive stormwater management program.

E3.6 EQUITY AND PUBLIC ACCEPTANCE

Public acceptance is critical for the success of a stormwater management program and the implementation of the required funding options. Public acceptance of a new or increased method of funding is dependent upon a clearly defined and understood need, reasonable costs, and a perception of equity in the financial impact. Equity is another factor which usually requires a combination of options for the best overall funding strategy.

Equity can be somewhat difficult to convey in some cases, especially with variations in the definition. Equity among users, equity related to fairness and ability to pay, and equity between present and future customers are not necessarily incompatible but can be difficult to balance. Perfect equity may not be cost-effective or even technically possible, but the public must perceive a basic fairness, a good faith and logical effort, and a general understanding of the relationship between cost and the level of benefit or service. The level of benefit is not as easily understood for drainage services as it is for water or wastewater. The public uses water and wastewater services on a daily basis, and the level of benefit and cost can be measured by usage and controlled somewhat by the customer.

After initial acceptance, the public will expect stability in the financial impact of the funding options, efficiency in the use of funds, and benefits and services that are apparent.

E4.0 REVENUE CAPACITY

The revenue capacity of a funding option is a key consideration. An option which does not provide sufficient revenue for its intended purpose may not be feasible even if all other criteria are favorable.

This section will assess the amount of funds that can be generated by the three primary funding options. The revenue capacities will be estimated using the available data from the City of Longview and assumed units of fees or assessments.

The secondary funding options are adopted for special purposes and specific projects. The revenue capacity of each option is usually tied to the cost of the service or project. Therefore, the revenue capacities of the secondary options should be considered as incidental for the requirements of the major costs of capital improvements and operation and maintenance of the overall stormwater management program.

E4.1 GENERAL FUND

The capacity of the general fund to provide additional revenue for a stormwater management plan is basically a function of an increase in the City's property tax rate.

The City's general fund budget for the fiscal year beginning October 1, 1989 was essentially balanced, with revenues and expenditures projected at \$22.6 million and an ending fund balance estimated at \$1.94 million. The budget for the Street Department includes funds for drainage work, such as installation and maintenance of storm sewers, ditches and other drainage structures. The budget included less than \$20,000 for that function although almost \$90,000 was expended the year before. There does not appear to be a reasonable chance for a significant increase in general funds budgeted for a stormwater management plan without increasing available funds.

Approximately 84% of the general fund revenues for 1990 were projected from taxes, including 41% from ad valorem taxes, 34% from sales taxes, and 9% from other business and occupational taxes.

The City's sales tax rate of 1% is at the legal maximum, and the only increase in revenues that can be anticipated is from an increase in economic activity. A 4% increase in sales tax receipts would yield approximately \$300,000; however, it is likely that little if any would be available for increased funding of a stormwater management program because of inflationary increases and other demands on all expenses. Similarly, any increases from other business and occupational taxes or from other minor general fund revenue sources would not likely provide any significant revenues for an increase in future drainage expenditures.

Therefore, by default, an additional and stable source of revenue from the general fund would require an increase in the City's ad valorem tax rate. The City's 1989-1990 tax rate was \$0.49 per \$100 valuation, including \$0.145 for debt service and \$0.345 for the general fund. The proposed tax rate for 1990-1991 is \$0.50 per \$100 valuation, including \$0.146 for debt service and \$0.354 for the general fund.

ESPEY, HUSTON & ASSOCIATES, INC.

The 1989 assessed valuation for the City of Longview was \$2,696,701,493. Each \$0.01 of a tax increase would generate about \$256,000 annually at 95% collections.

In summary, the revenue capacity of the general fund for a stormwater management plan is considered to be a direct function of an increase in the City's ad valorem tax rate, with approximately \$256,000 provided annually for each \$0.01 of tax assessment.

E4.2 STORM DRAINAGE UTILITY SERVICE CHARGES

The revenue capacity of stormwater service charges is a function of the rate methodology and design, the size of the service area, and the unit charges that are adopted.

Most of the rate methodologies employ some standard billing unit, such as an equivalent single-family residence. A base or unit charge is applied to each billing unit. Other types of property are assessed in multiples of the base fee. The multiples are calculated differently in each methodology, using factors such as gross area, slope, and intensity of development, and generally range from 2 to 5. Thus an equivalent area of another type of development would be assessed at 2 to 5 times the base charge for a single-family residence.

The general conclusion from records and information available from other cities which have stormwater service charges is that the upper limit of public acceptance is about \$3 per month for an equivalent single-family residence. For purposes of this exercise to estimate the revenue capacity for Longview, a base charge of \$1 per month will be used. For multi-family, commercial and industrial development, the multiple will be assumed at 3.5. This multiple is considered a representative ratio of the average impervious area of single-family development versus that of the other types. The average density for single-family development in Longview is about three units per acre (19,900 units divided by 6,410 acres). Thus, the estimated revenue from an acre of commercial development would be \$10.50 per month (3 units per acre x 3.5 x \$1.00 per equivalent unit).

Table E-1 presents a summary of the estimated annual revenues for the City of Longview based on the assumptions above.

TABLE E-1
ESTIMATED ANNUAL REVENUE
STORMWATER SERVICE CHARGE

Development Type	Units	Acreage	Equivalent Units	Annual Base Charge	Annual Revenue
Single Family	19,902	6,409.4	19,902	\$ 12.00	\$ 238,824
Duplex	2,044	252.9	2,044	12.00	24,528
Multi-Family	6,599	351.1	3,686	12.00	44,232
Mobile Home	1,274	191.8	637	12.00	7,644
Commercial	--	1,599.1	16,790	12.00	201,480
Industrial	--	829.5	8,710	12.00	<u>104,520</u>
TOTAL					\$621,228

Master Drainage Study
Longview, Texas
Contract No. 90-483-765

The following maps are not attached to this report. They are located in the official file and may be copied upon request.

Watershed and Subarea Delineations
(Work Map)

Please contact Research and Planning
Fund Grants Management Division at
(512) 463-7926 for copies.